

INSTRUÇÃO DE MONTAGEM

EMISSÃO: 20/01/2021
REVISÃO: 000 (20/01/2021)

PANDIN®

Soluções em Ambientes



Gaveteiro

Aereo 2 Gv

Linha P25 TUB



Assista o Video de Montagem

Peças

COD.	PRODUTO	QUANT
A	CORPO DE GAVETA	02
B	FRENTE GAV FECH	01
C	FRENTE GAV LISA	01
D	LAT DIR/ESQ	02
E	TRAVESSA SUPERIOR	02
F	TRAVESSA INFERIOR	02

Componentes

COD.	PRODUTO	QUANT
01	FECHADURA	01
02	PARAFUSO 3,5X22	04
03	PARAFUSO 4.5X14	06
04	PARAFUSO 6X10	10
05	PARAFUSO M4X10	20
06	PARAFUSO M4X6	08
07	PORCA SEXTAVADA M4	08
08	PUXADOR	02
09	TRILHO CORREDIÇA	04
10	SUPORTE	04

- **Corpo de Gaveta (A)**

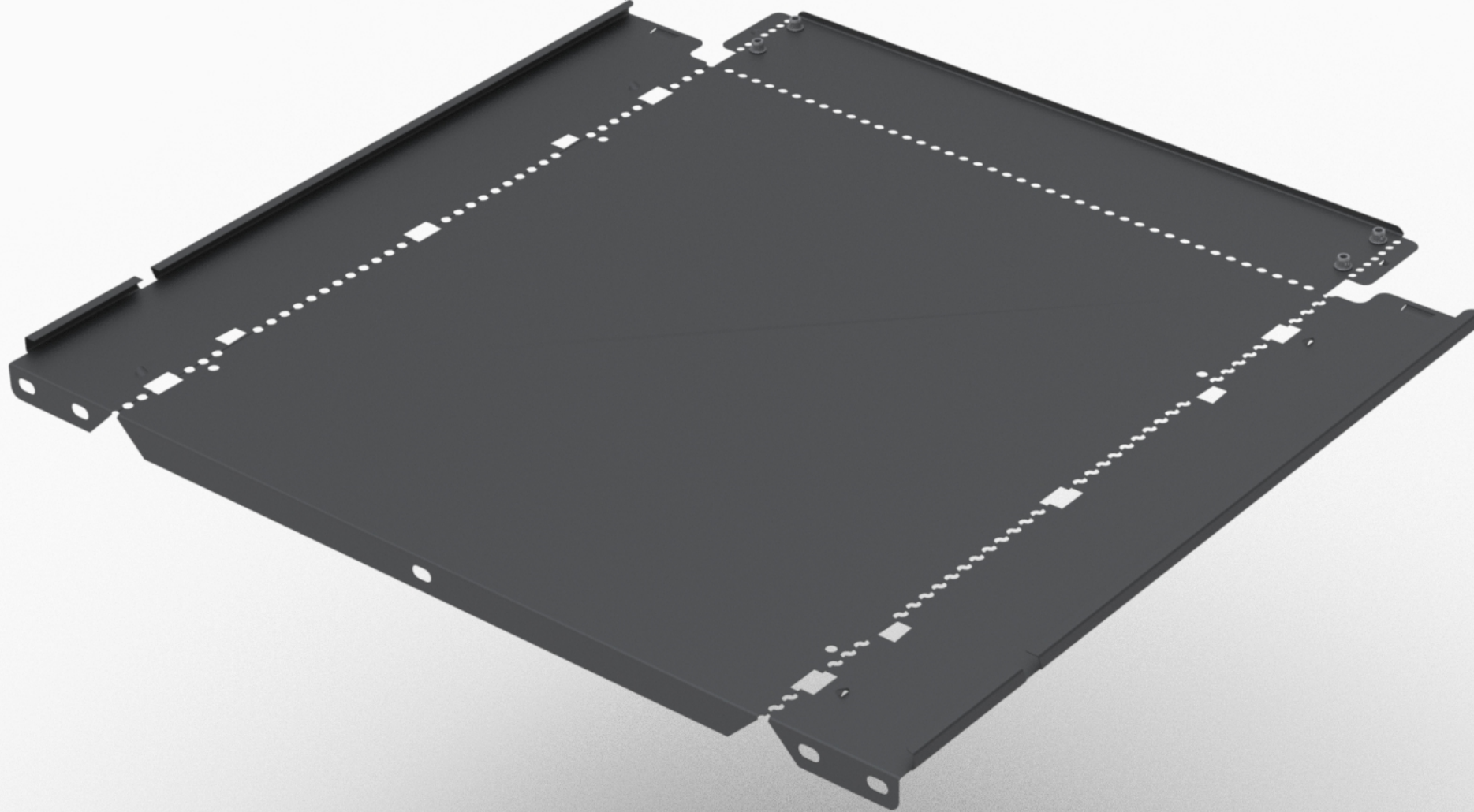

01° Passo

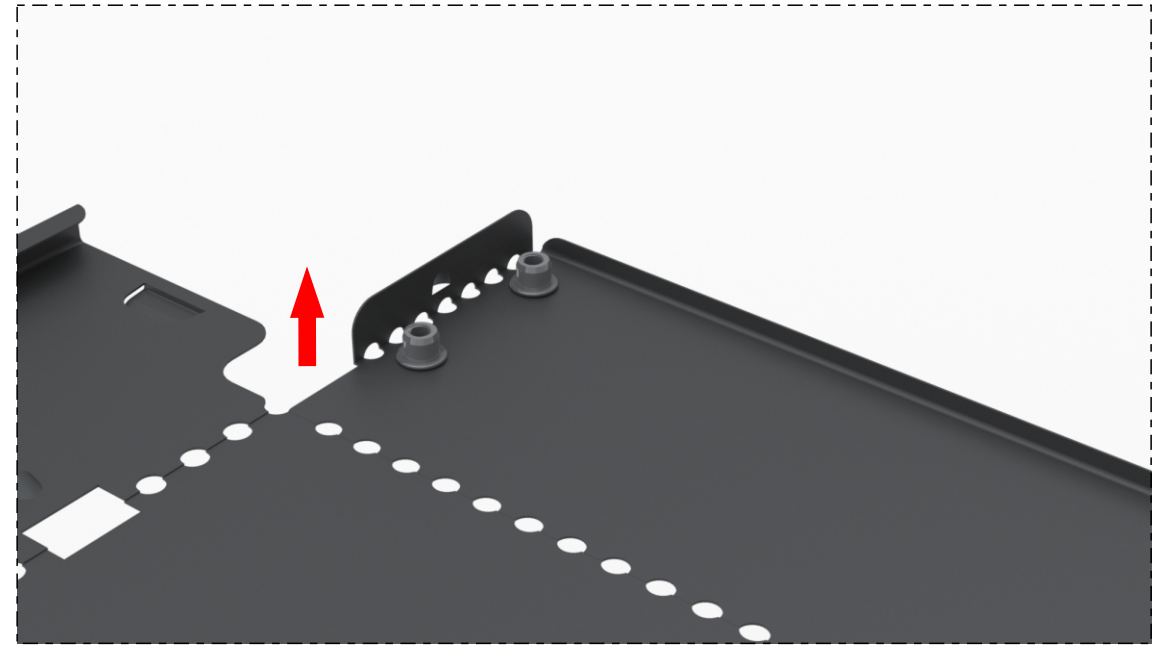
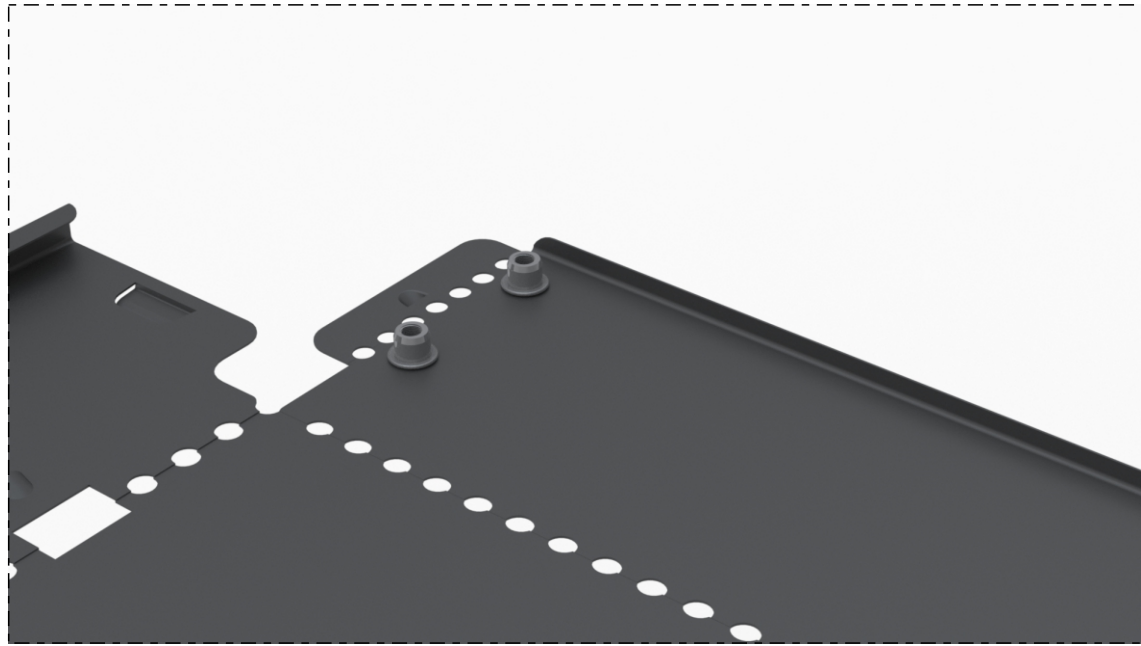

02° Passo

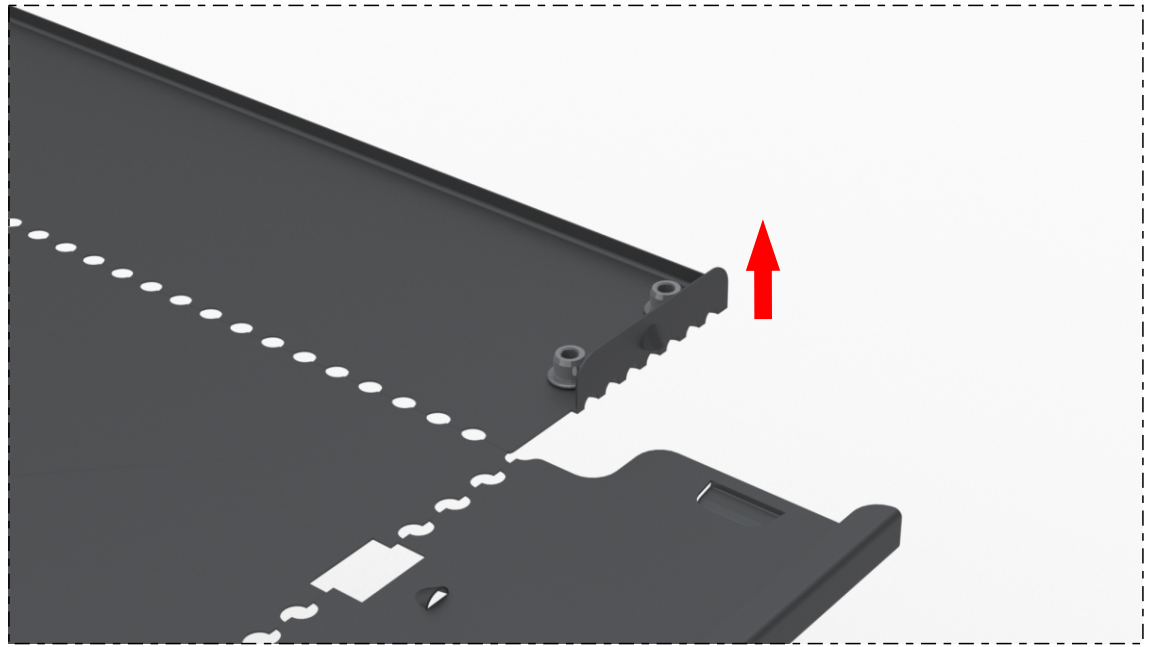
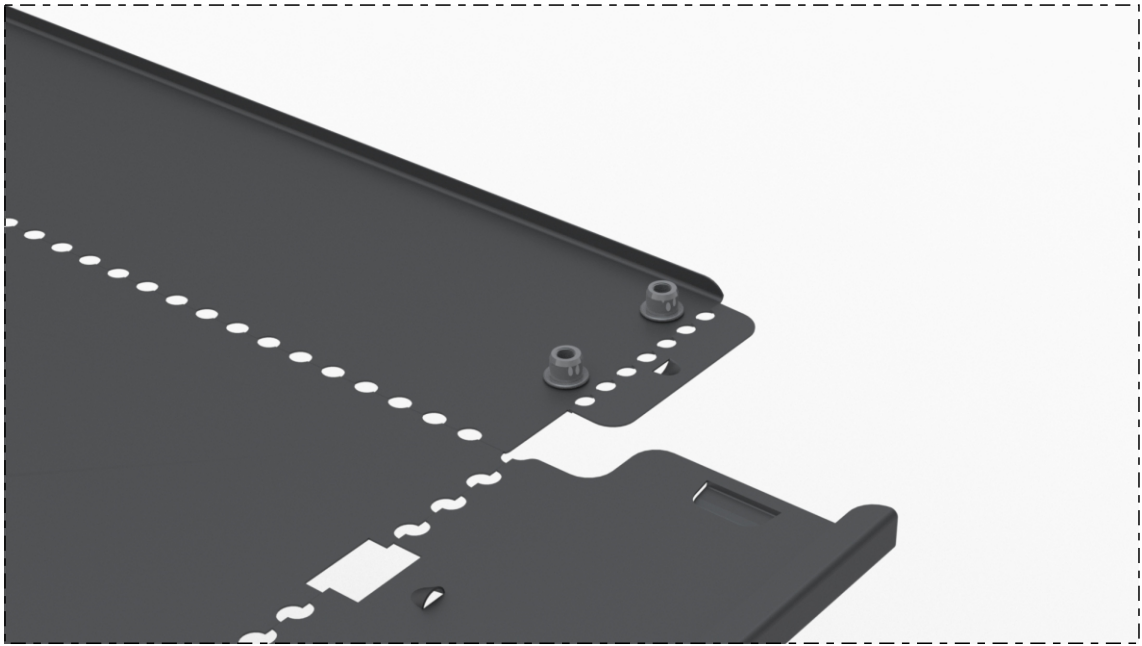

03° Passo

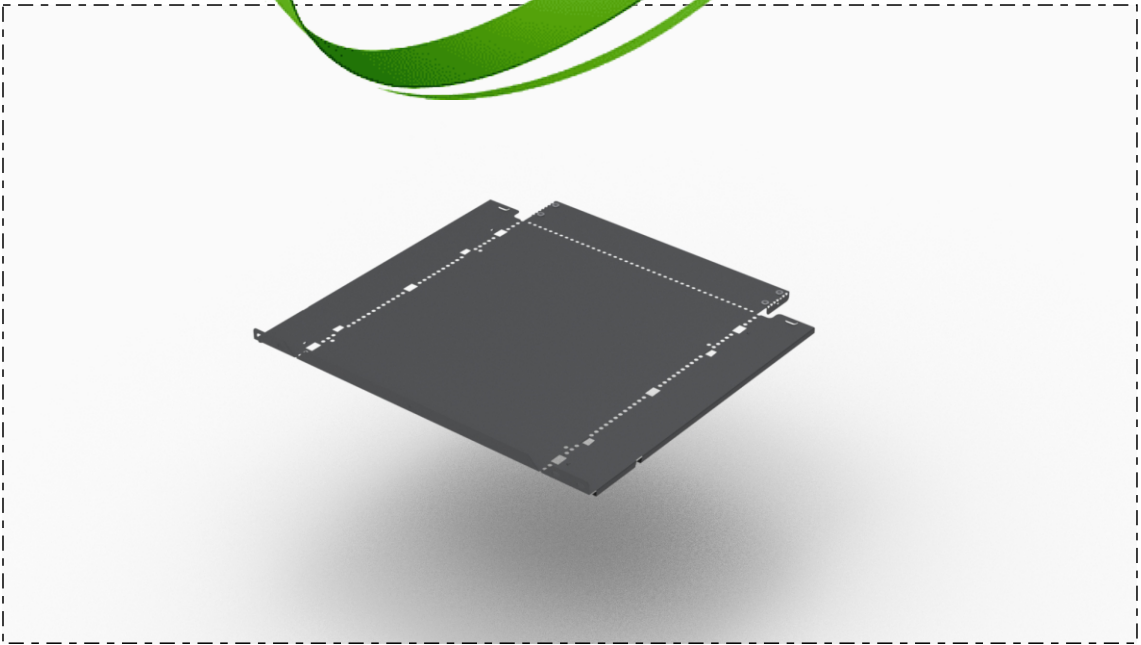
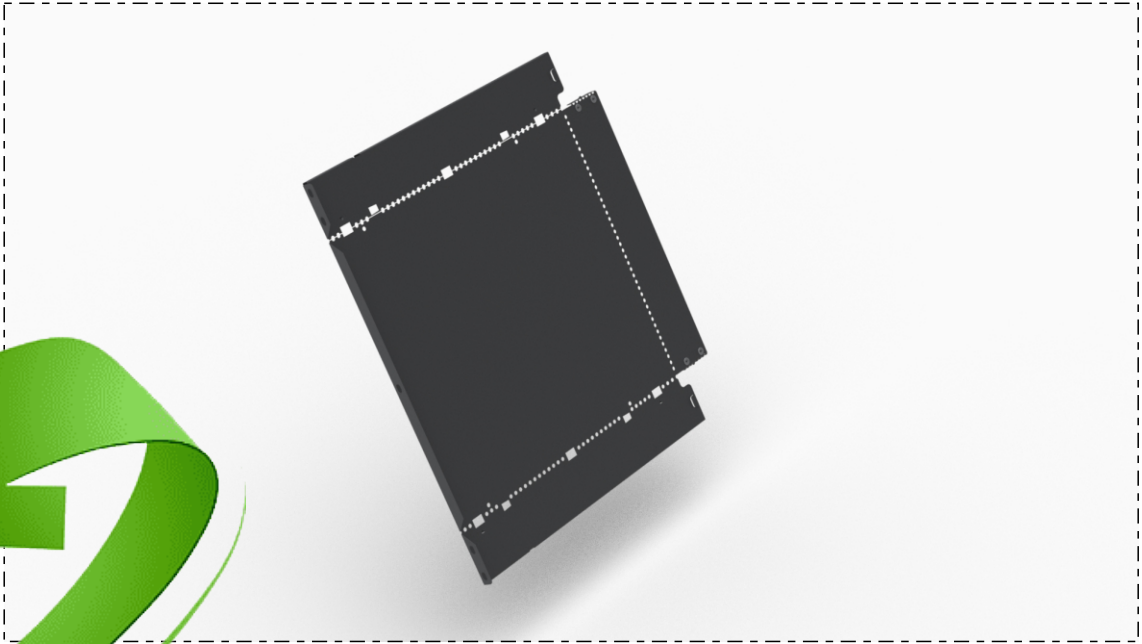
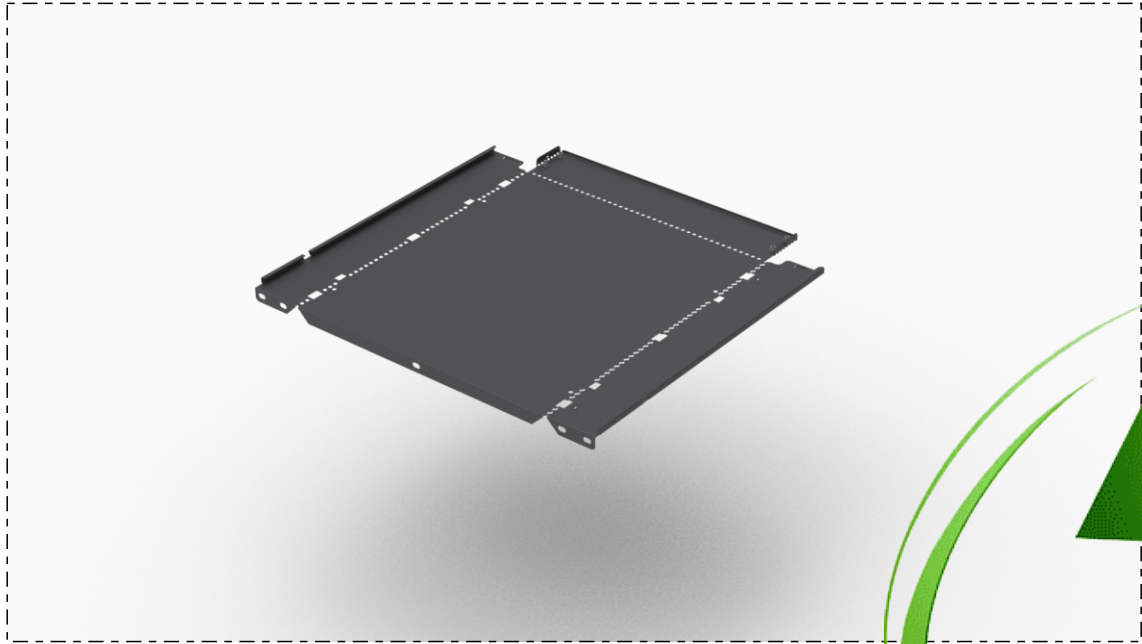

04° Passo

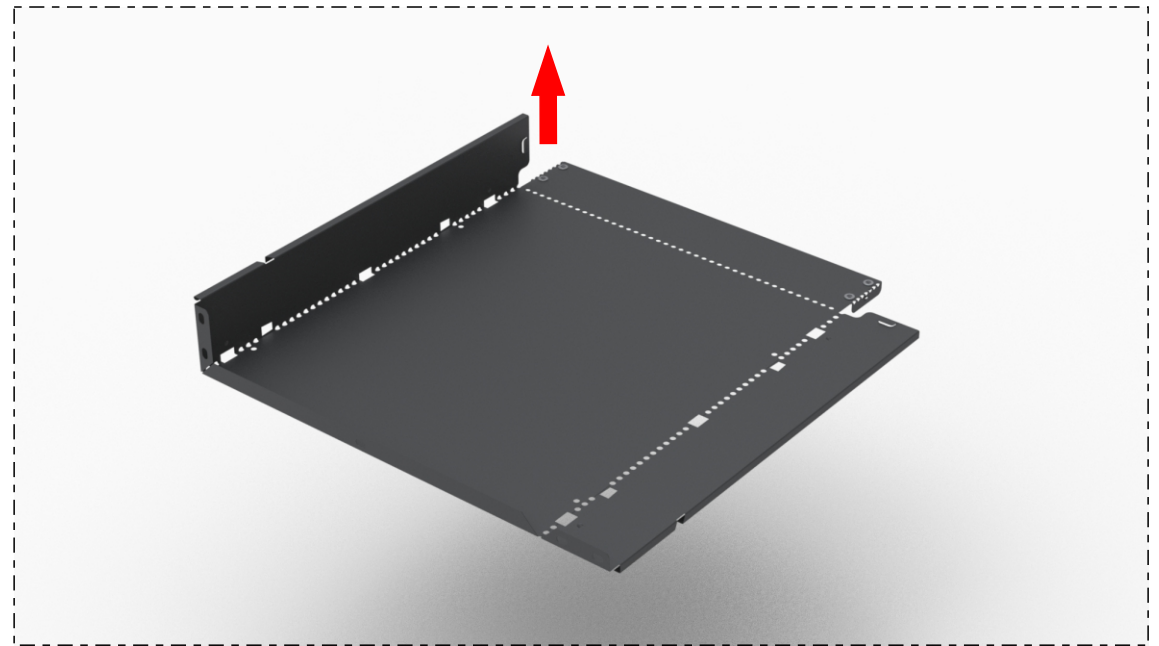
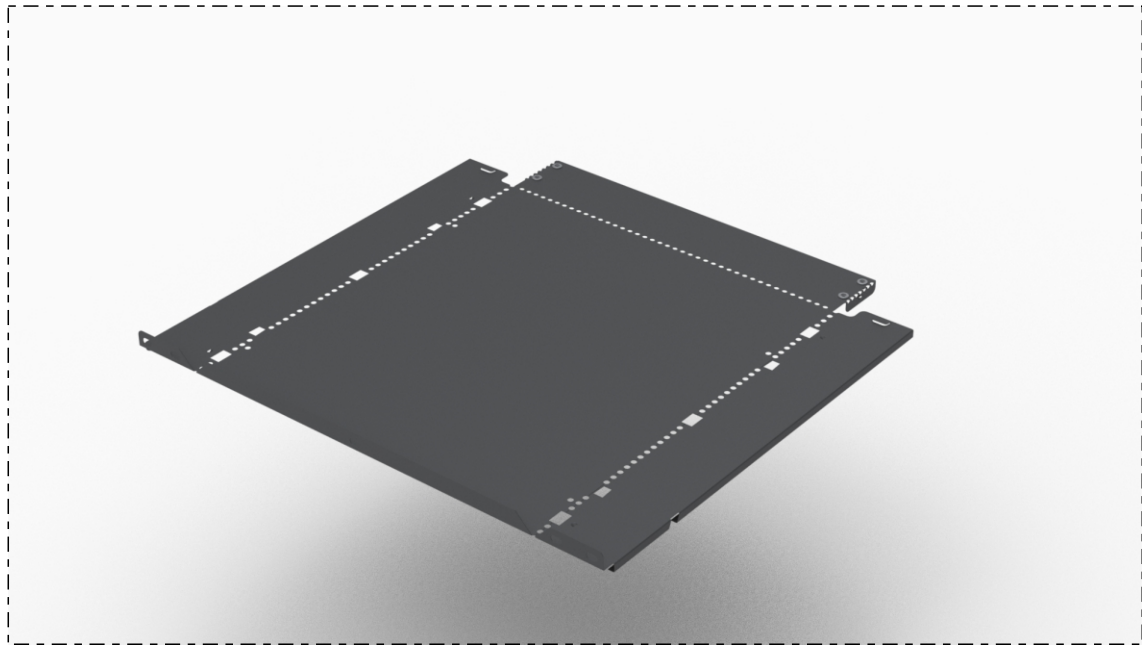

05° Passo

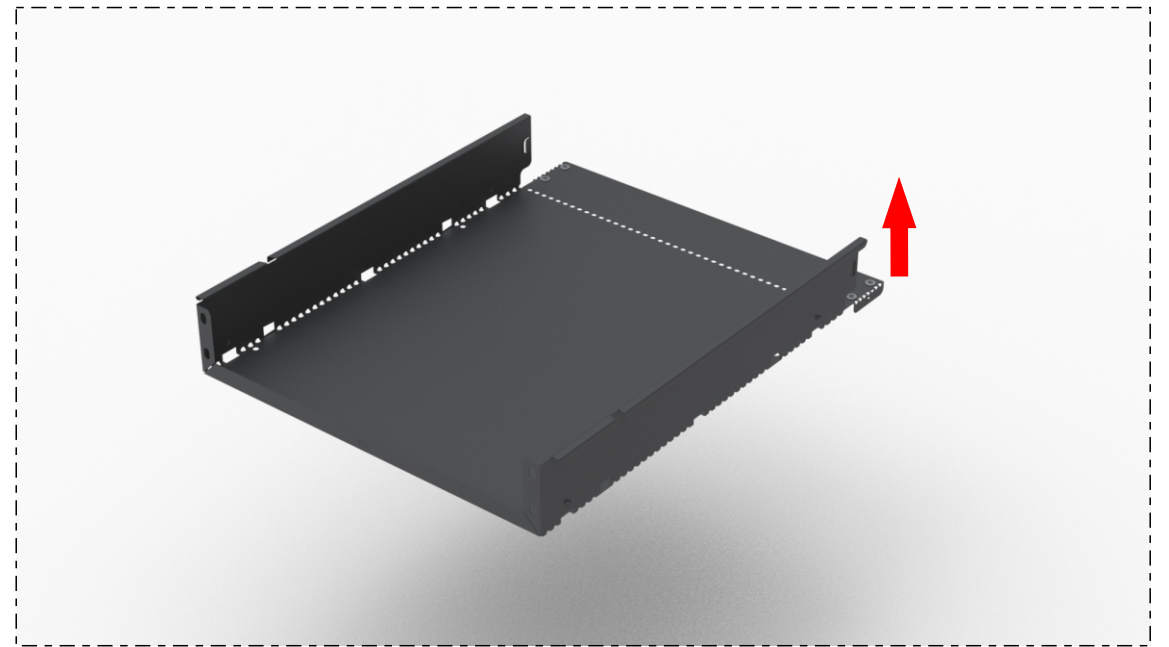
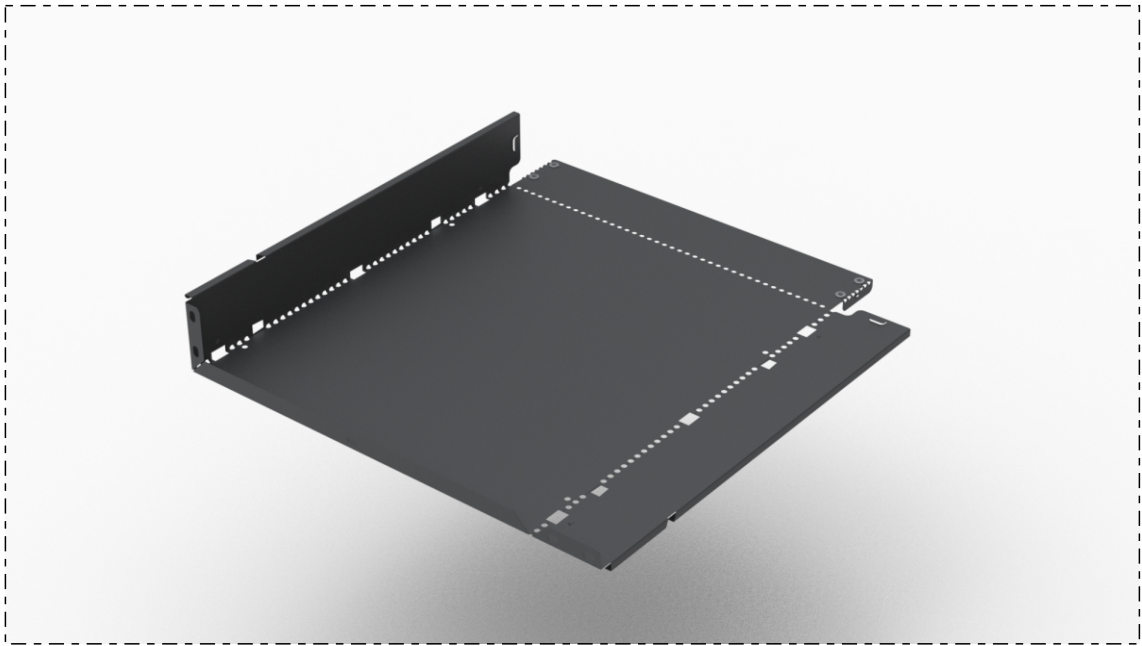

06° Passo

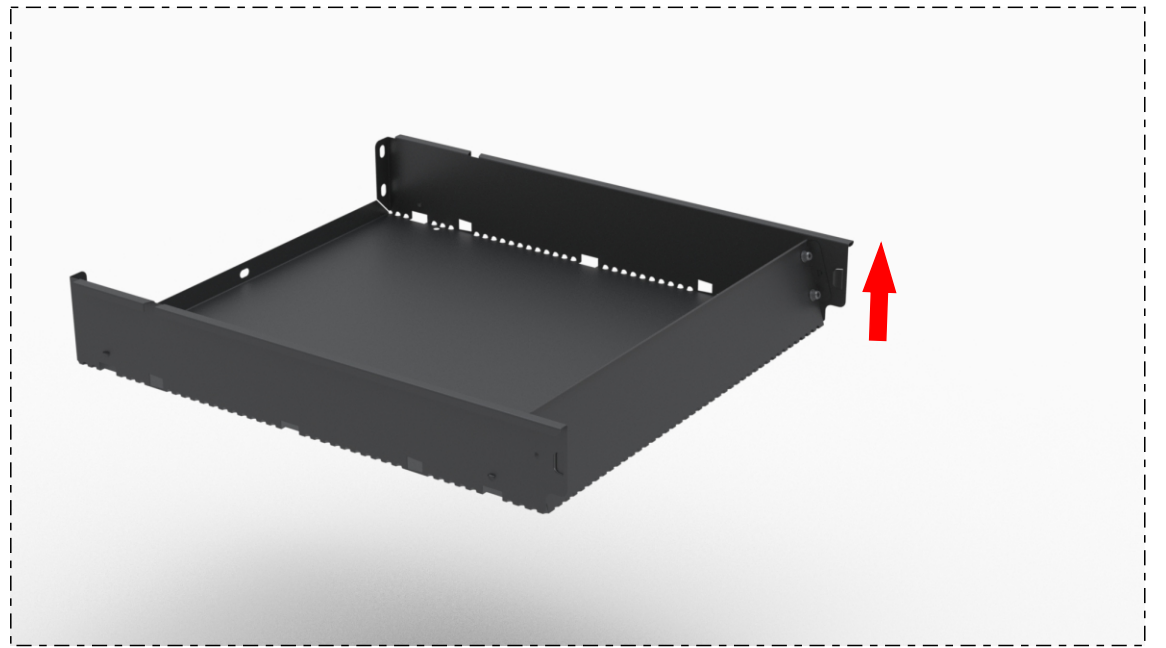
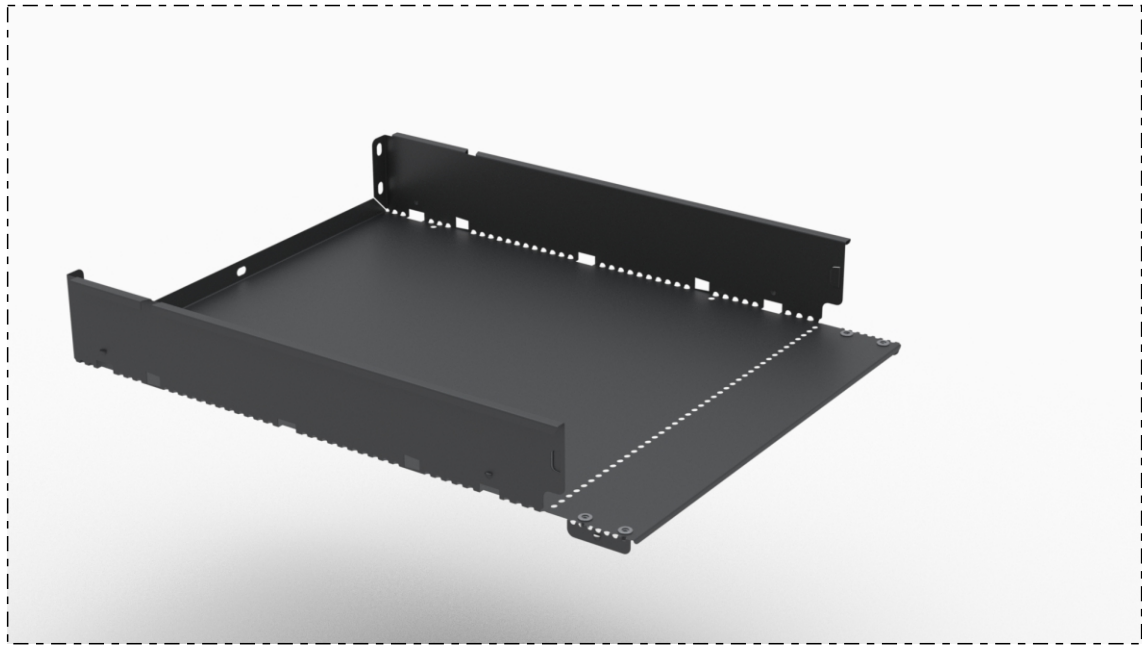

07° Passo

Trilho Corrediça (09) -

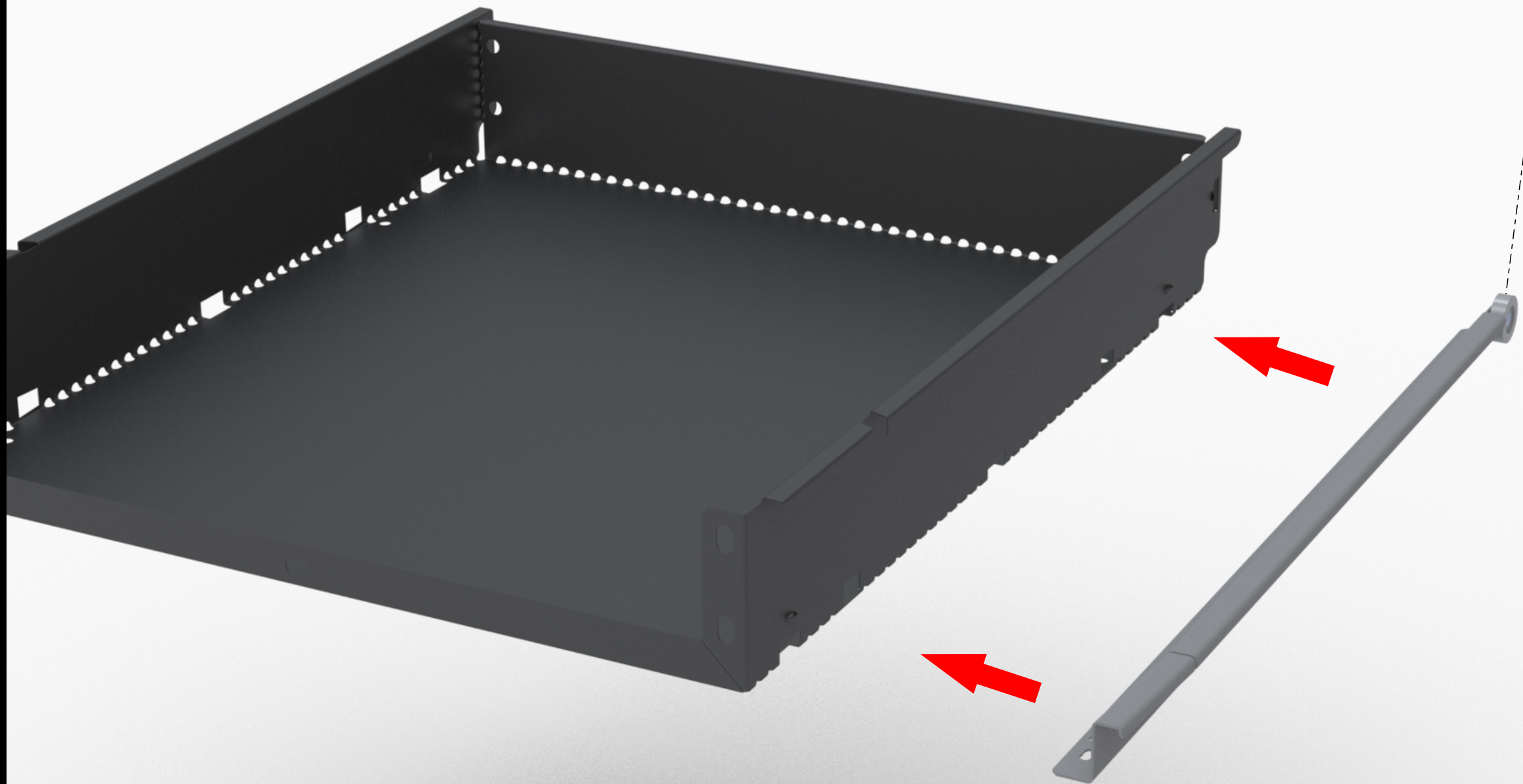

Parafuso M4x6 (06) -



09° Passo

- Trilho Corrediça (09)

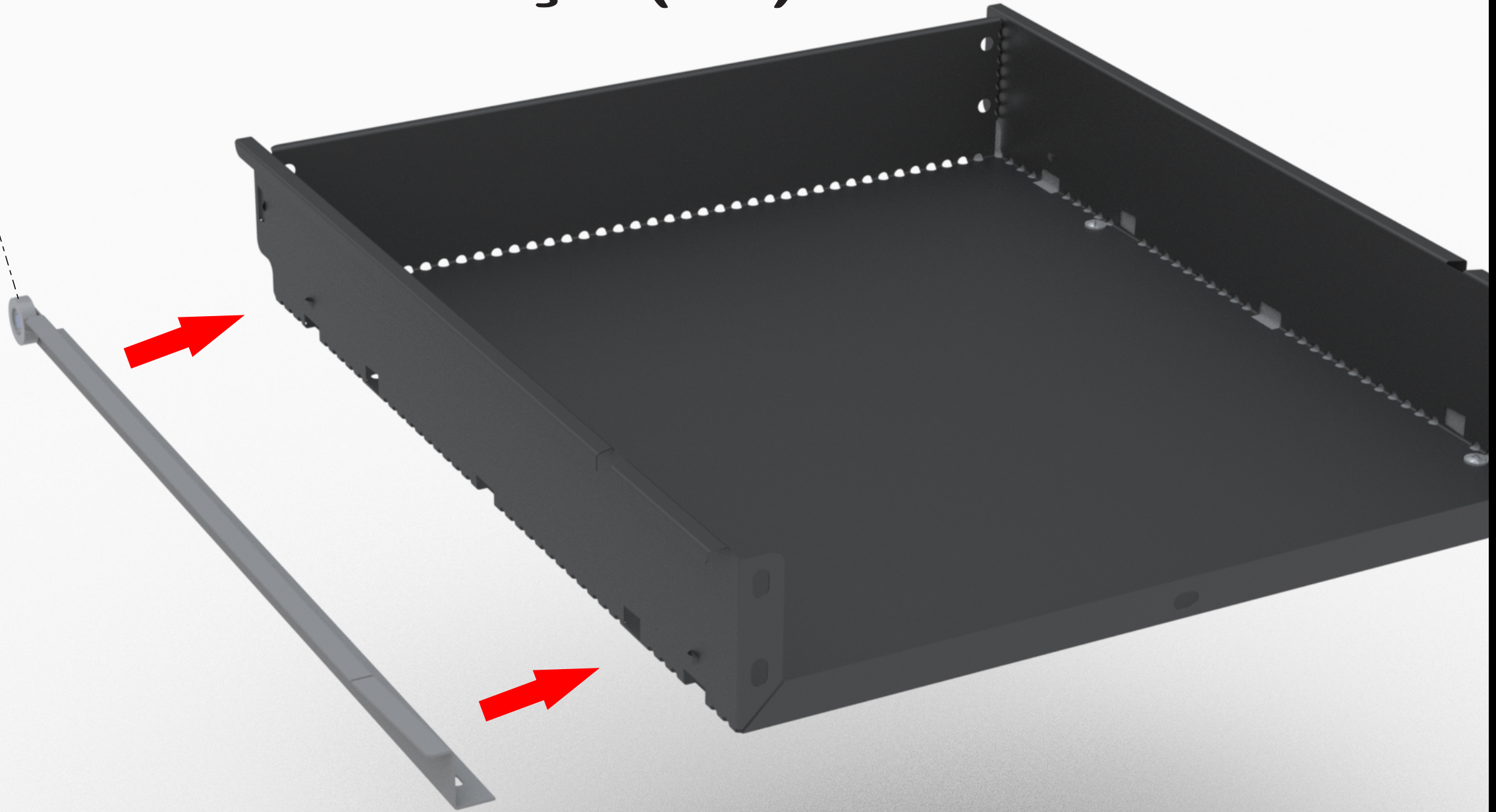

- Parafuso M4x6 (06)

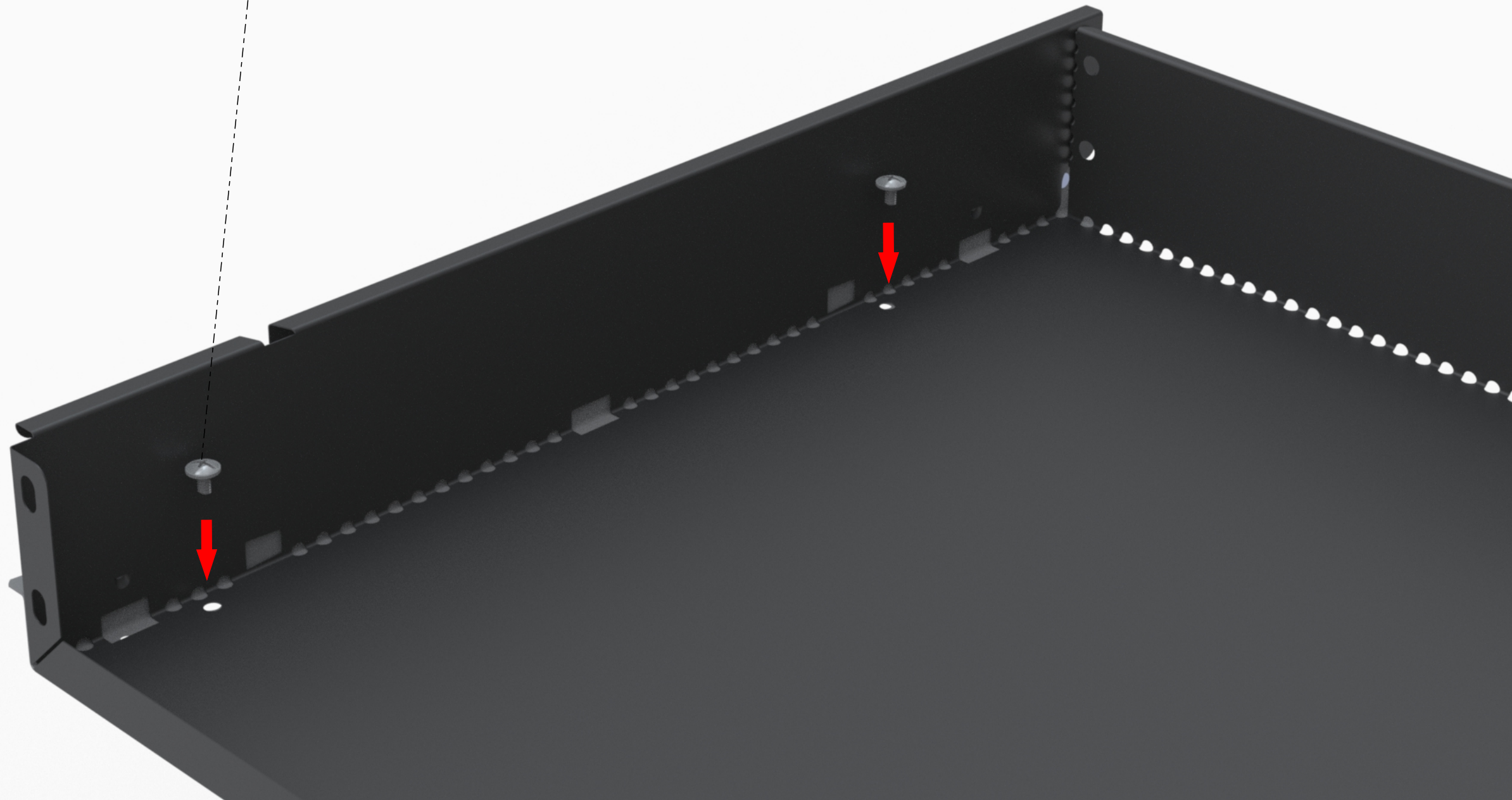

11° Passo

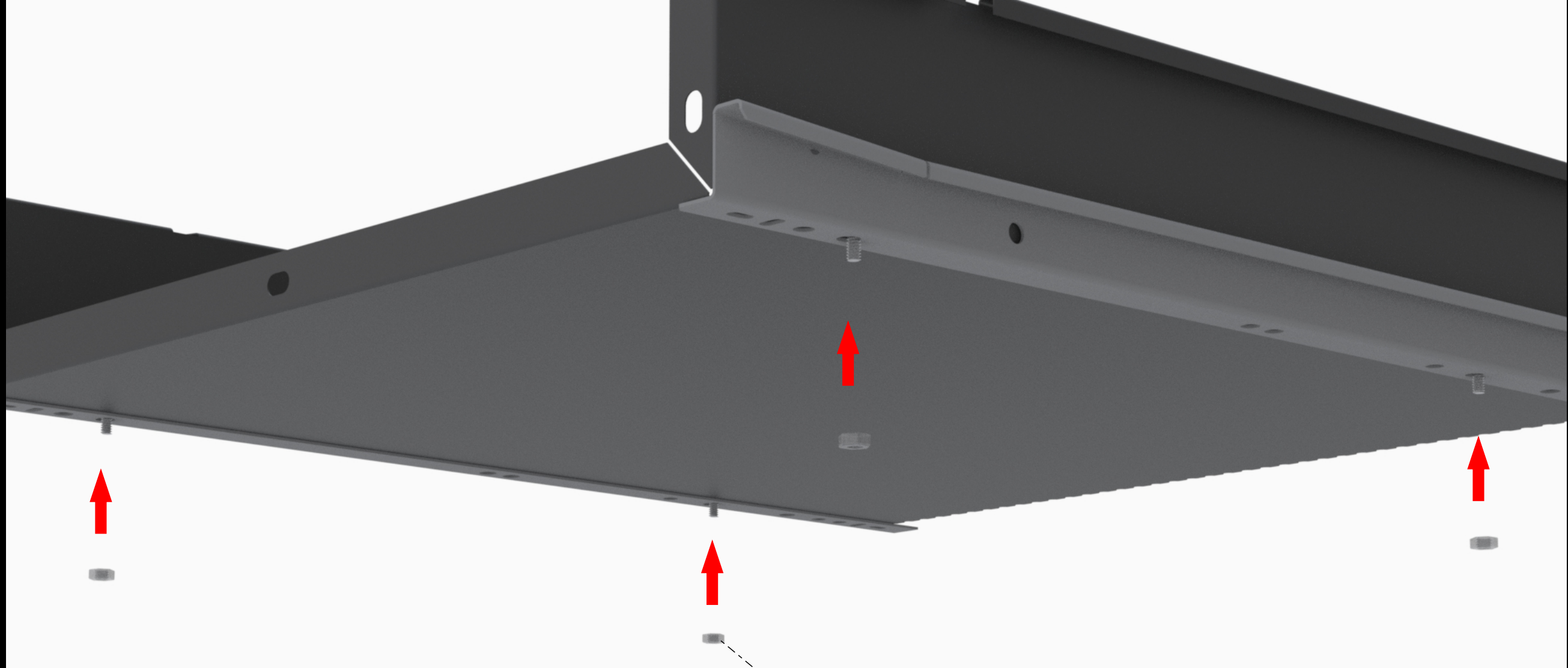

- Porca M4 (07)

12° Passo

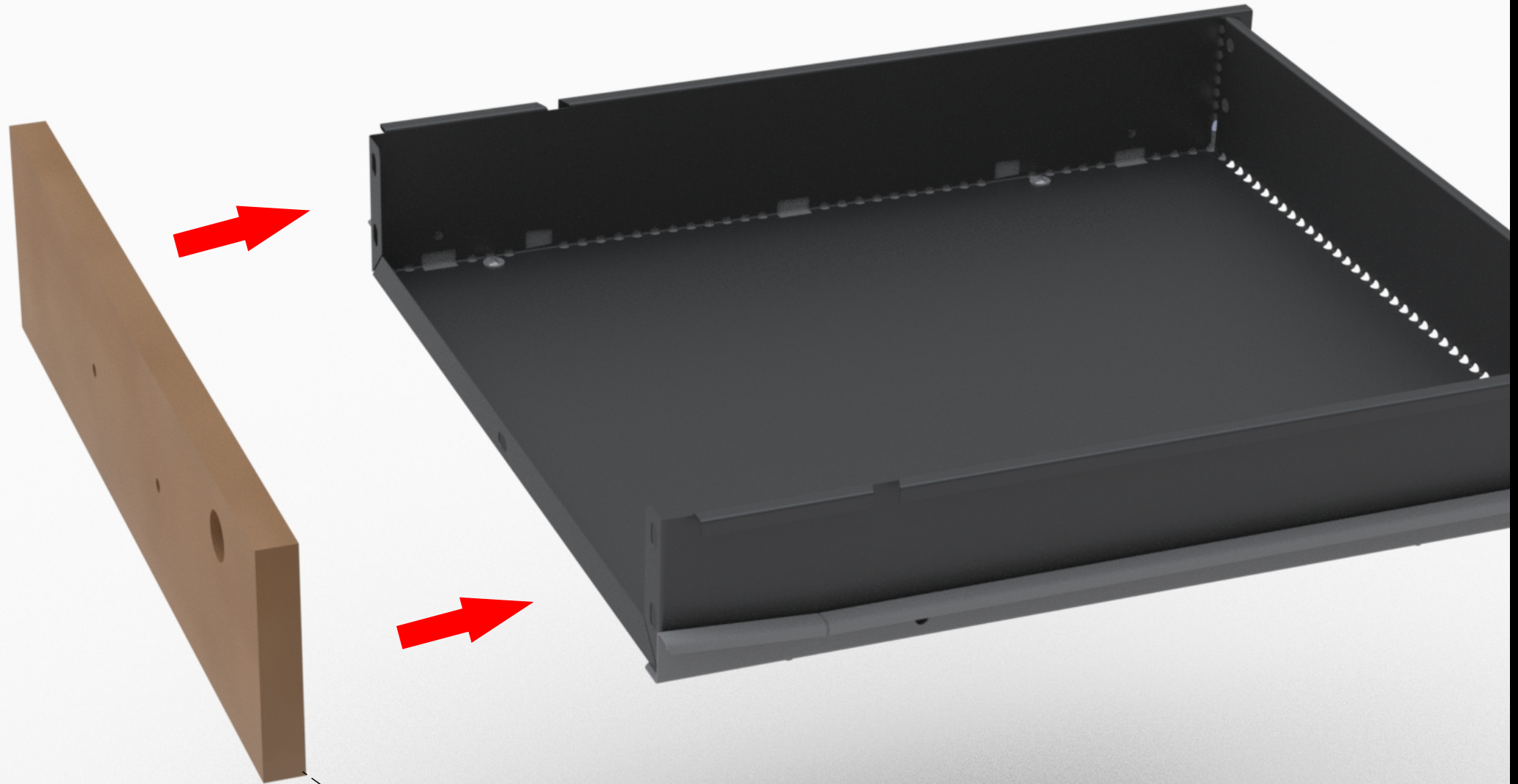

- Frente de Gav Fech (B)



- Parafuso 6x10 (04)

14° Passo

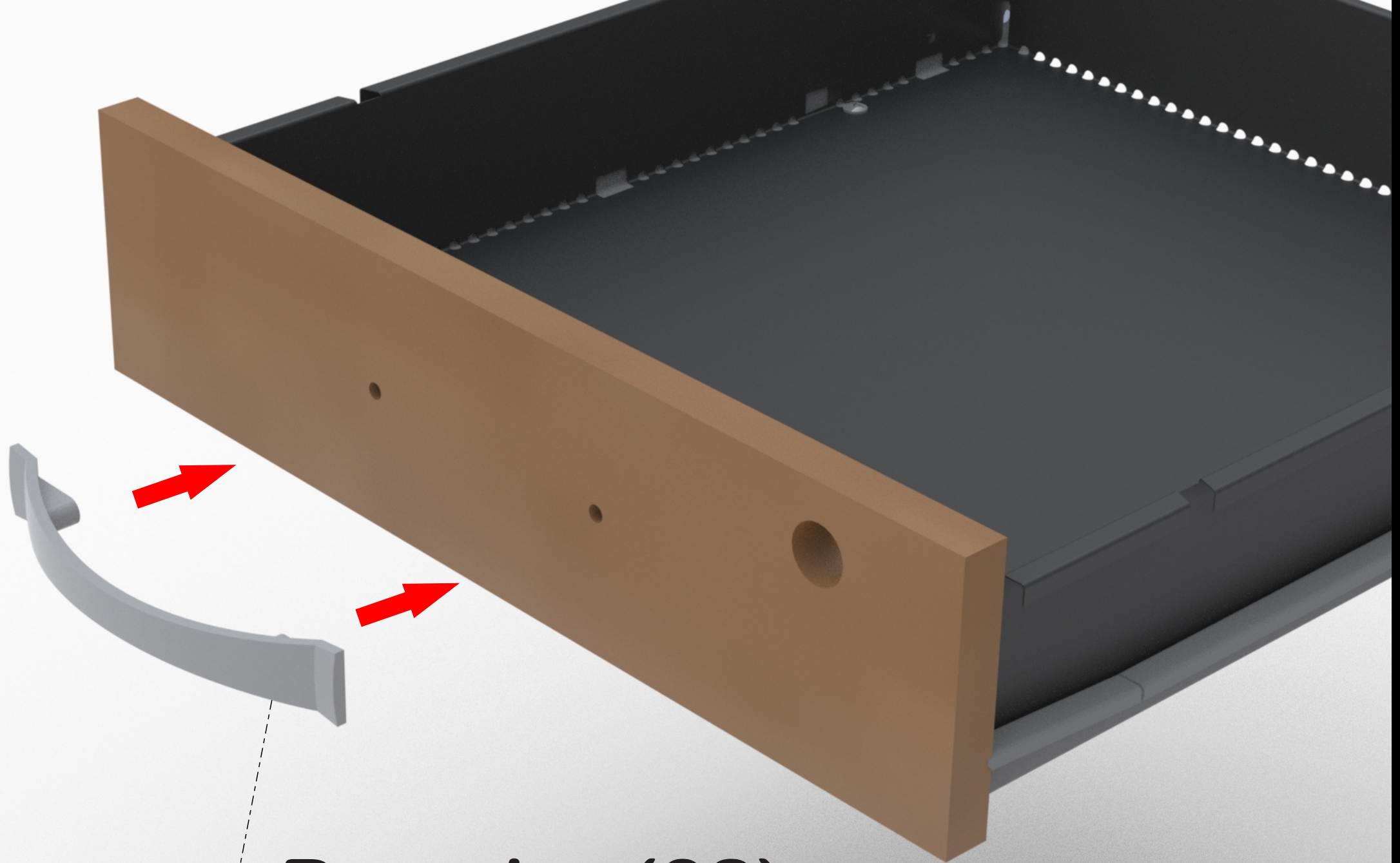

- Puxador (08)

15° Passo

Parafuso 3,5x22 -

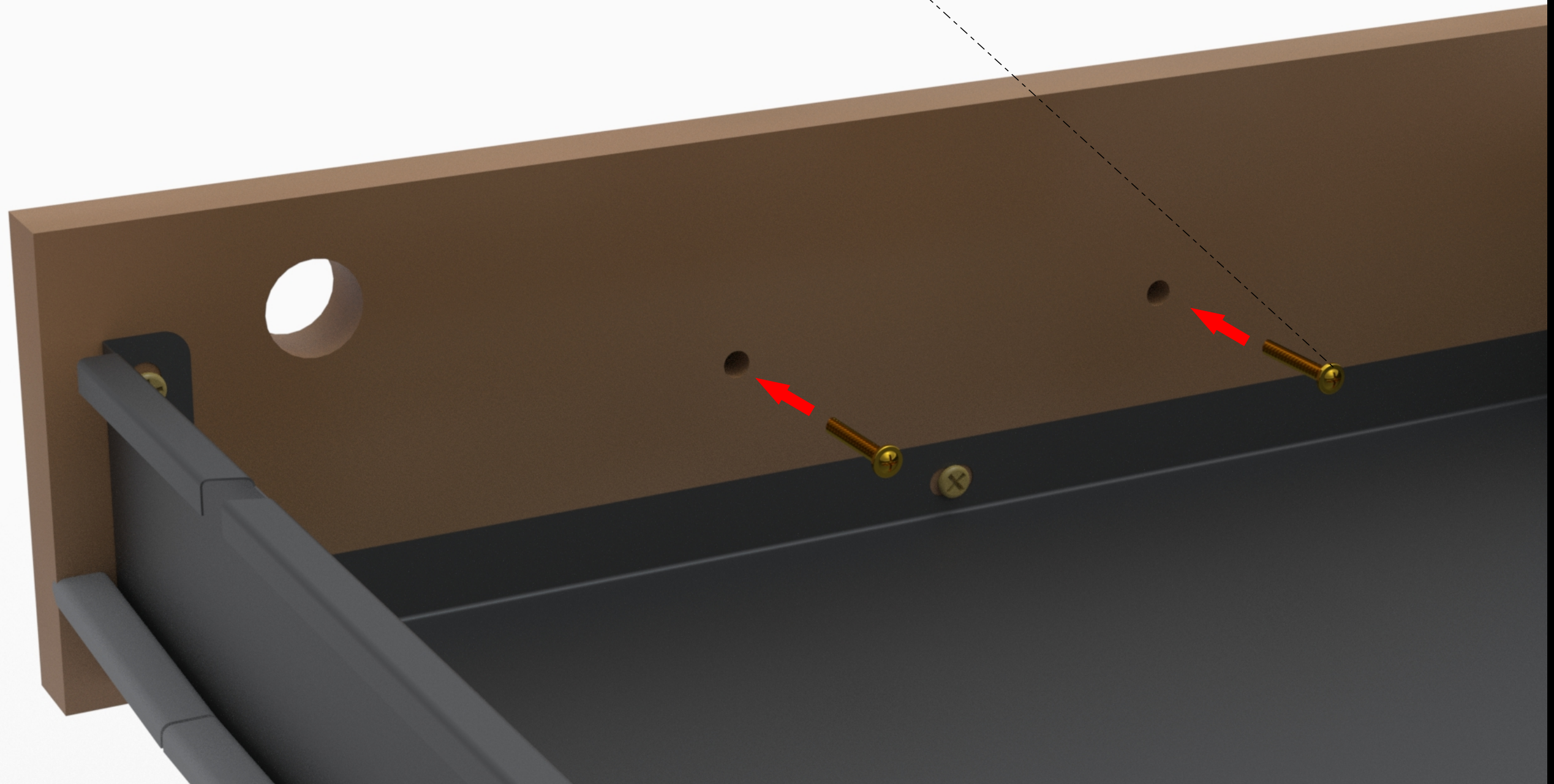

16° Passo

- Fechadura (01)

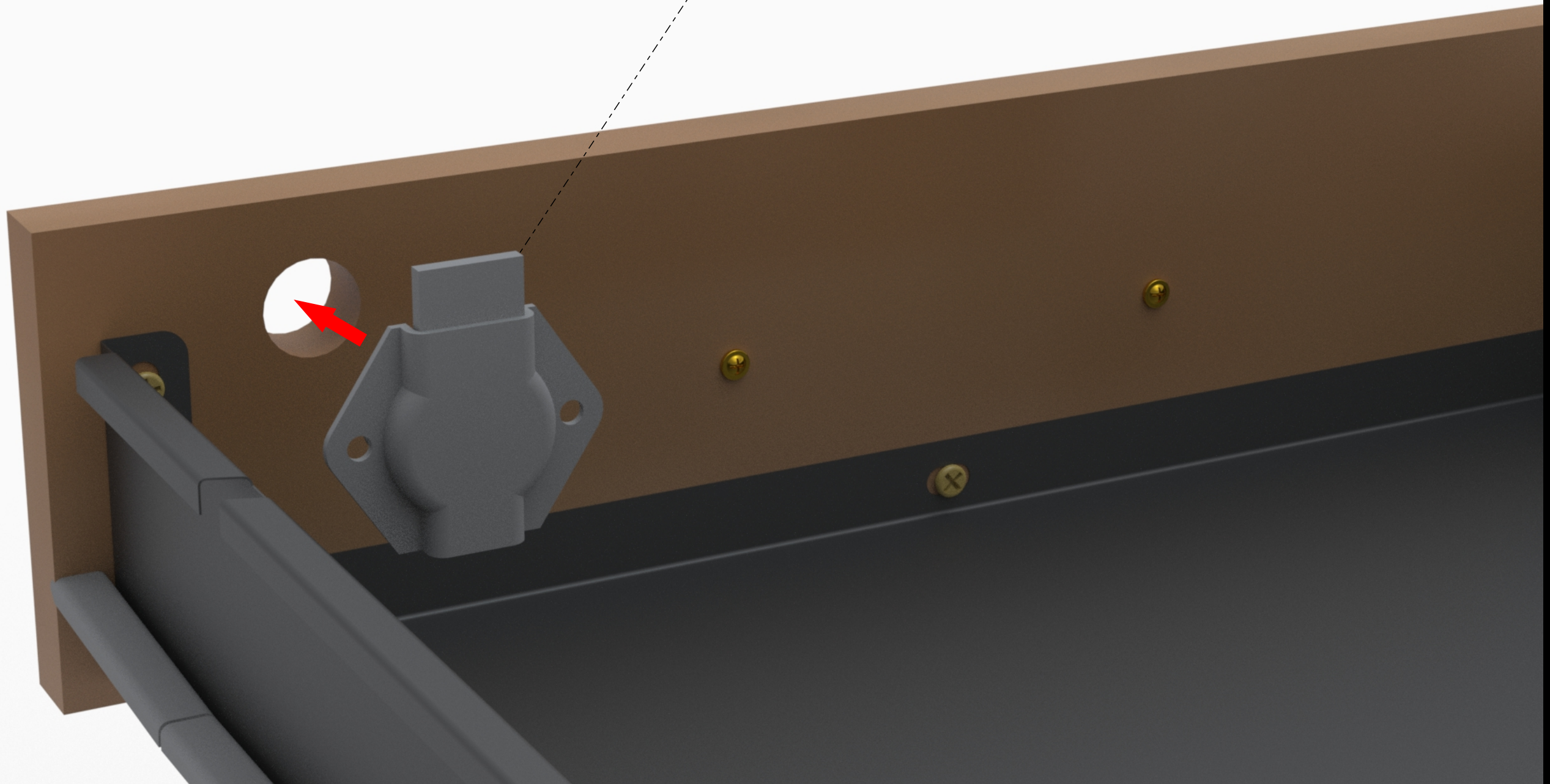

17° Passo

- Parafuso 4,5x14 (03)

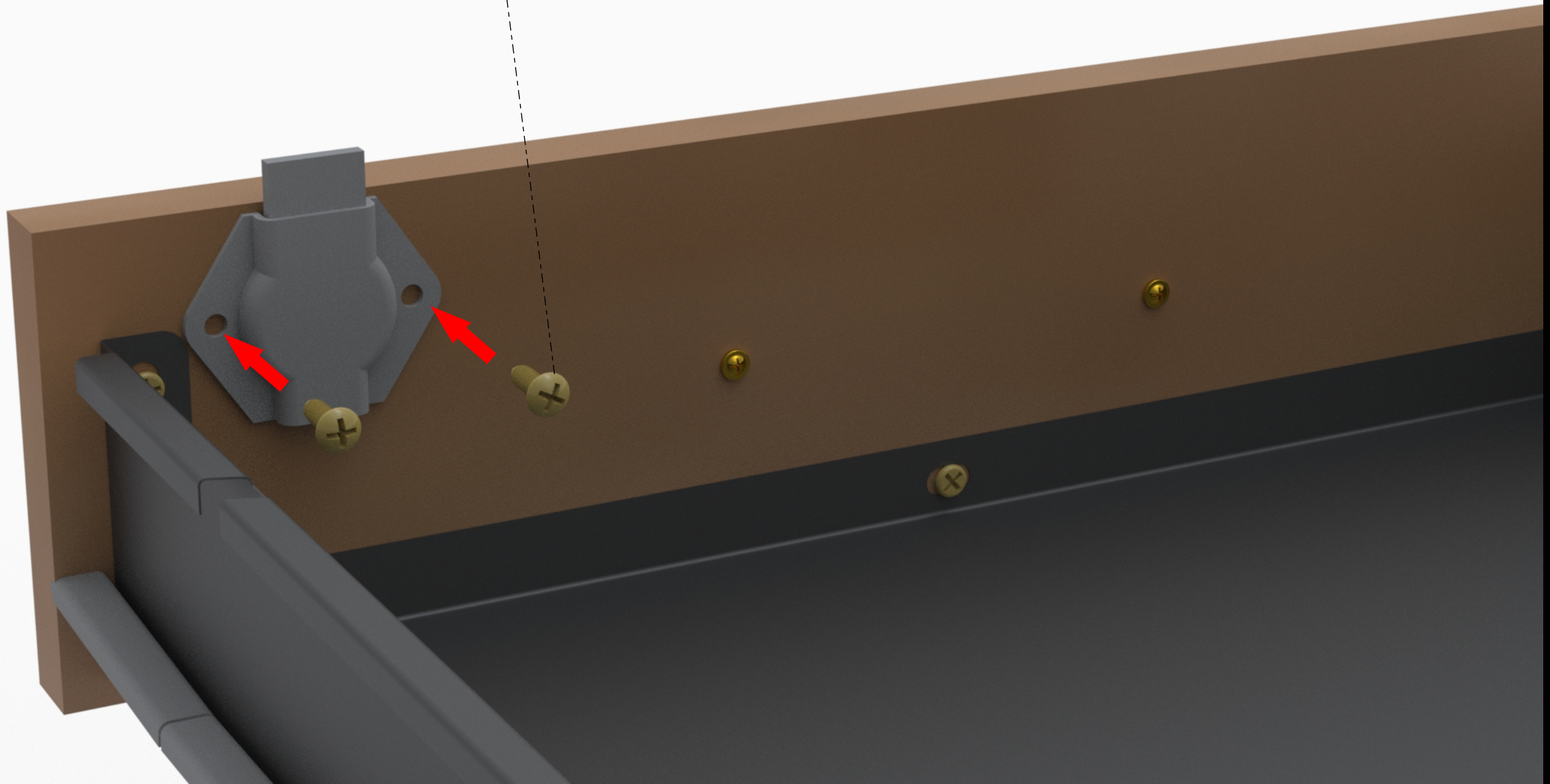

18° Passo

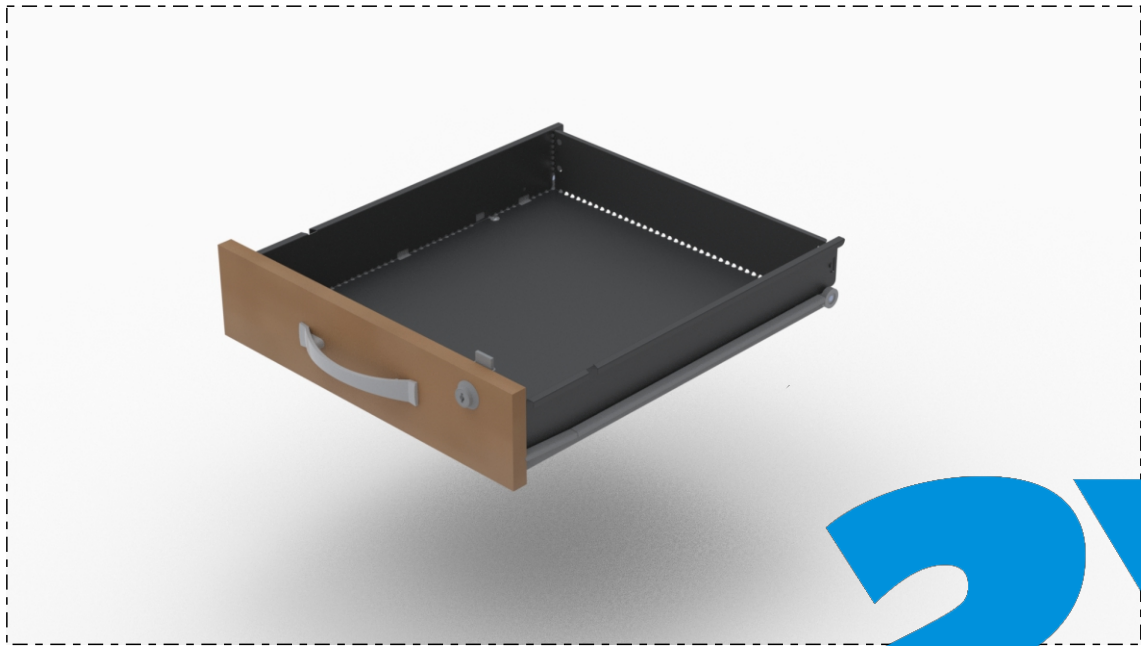

2x



19° Passo

- Lateral Dir/Esq (D)

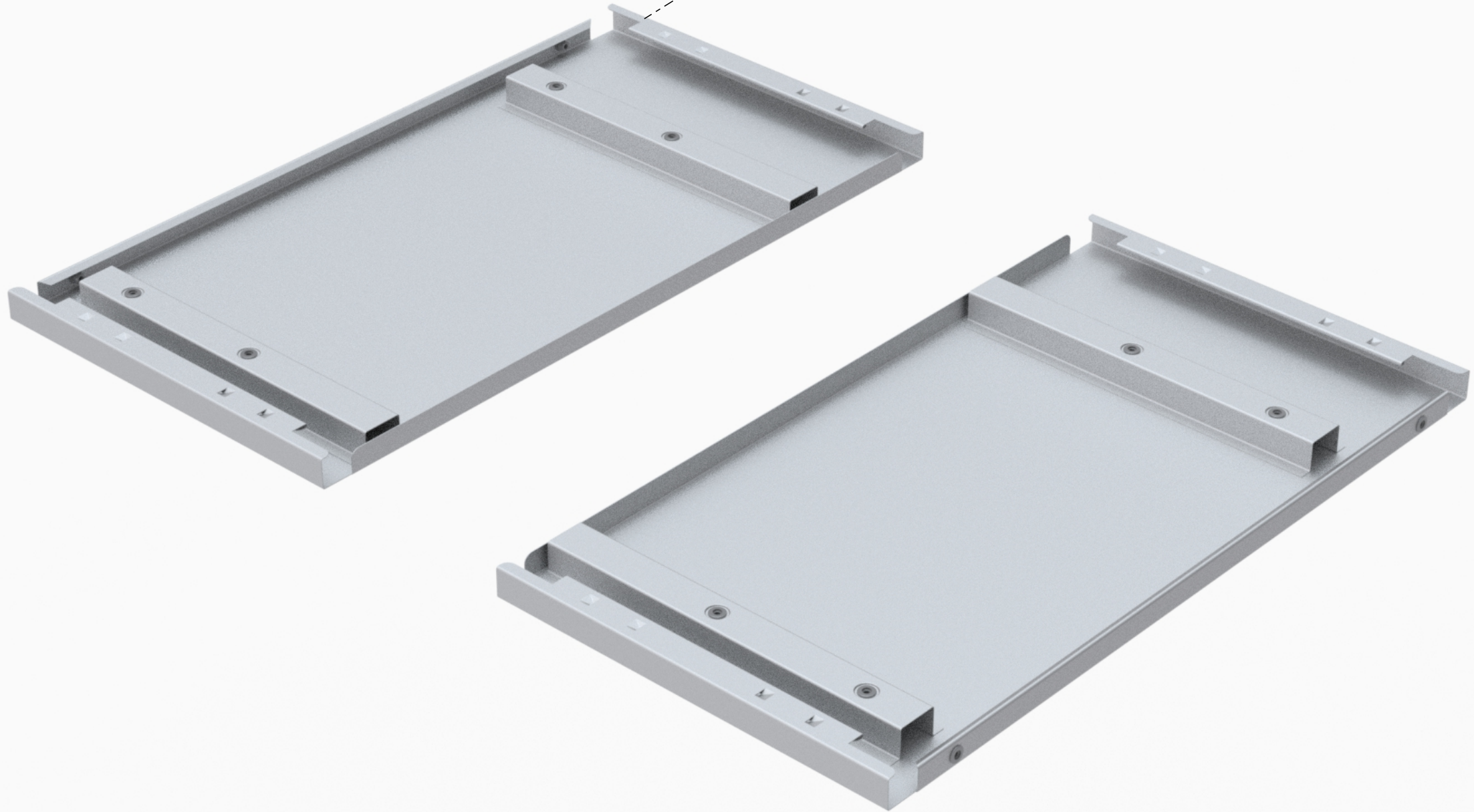

- Trilho Corrediça (09)



- Parafuso 6x10 (04)

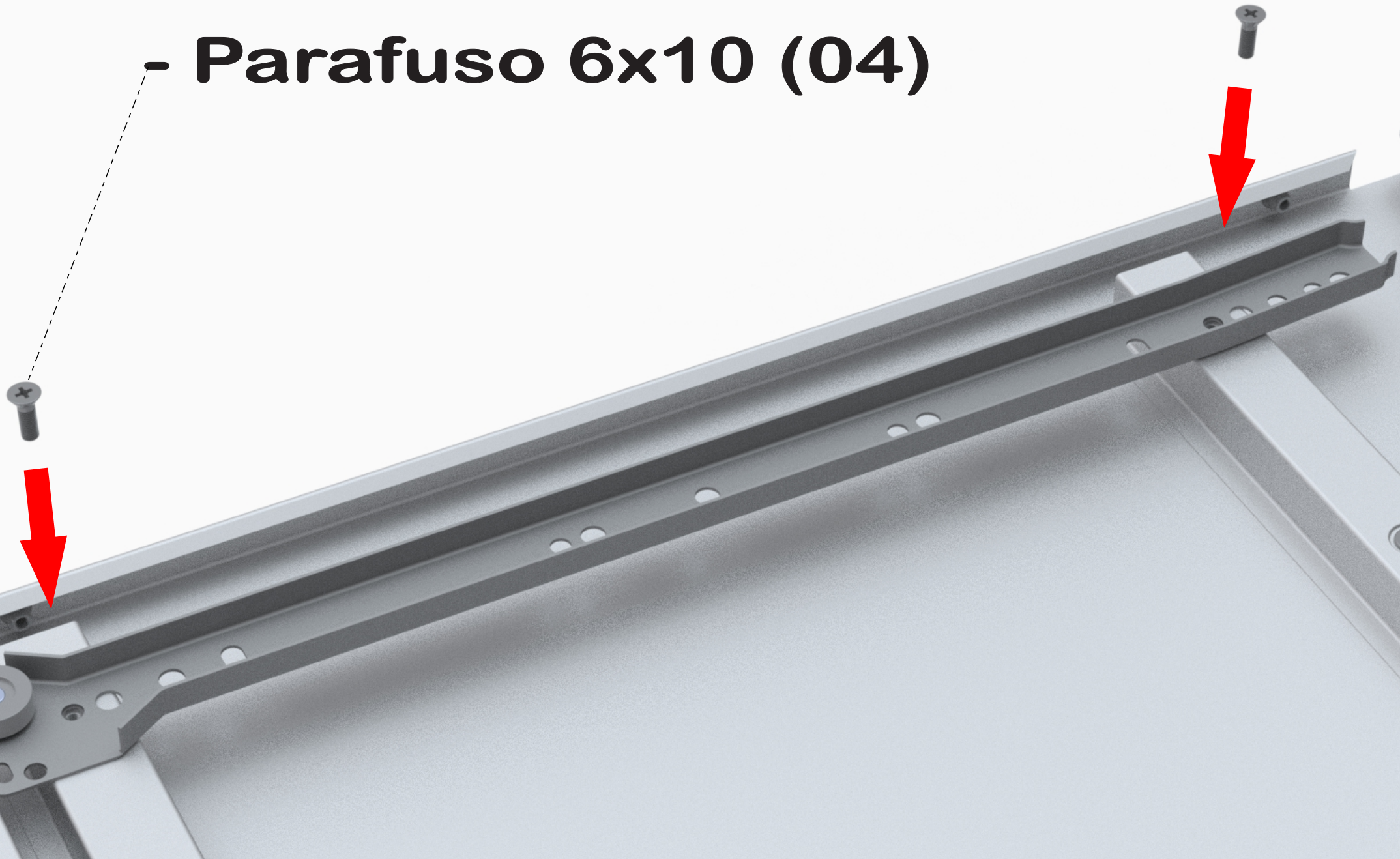

22° Passo

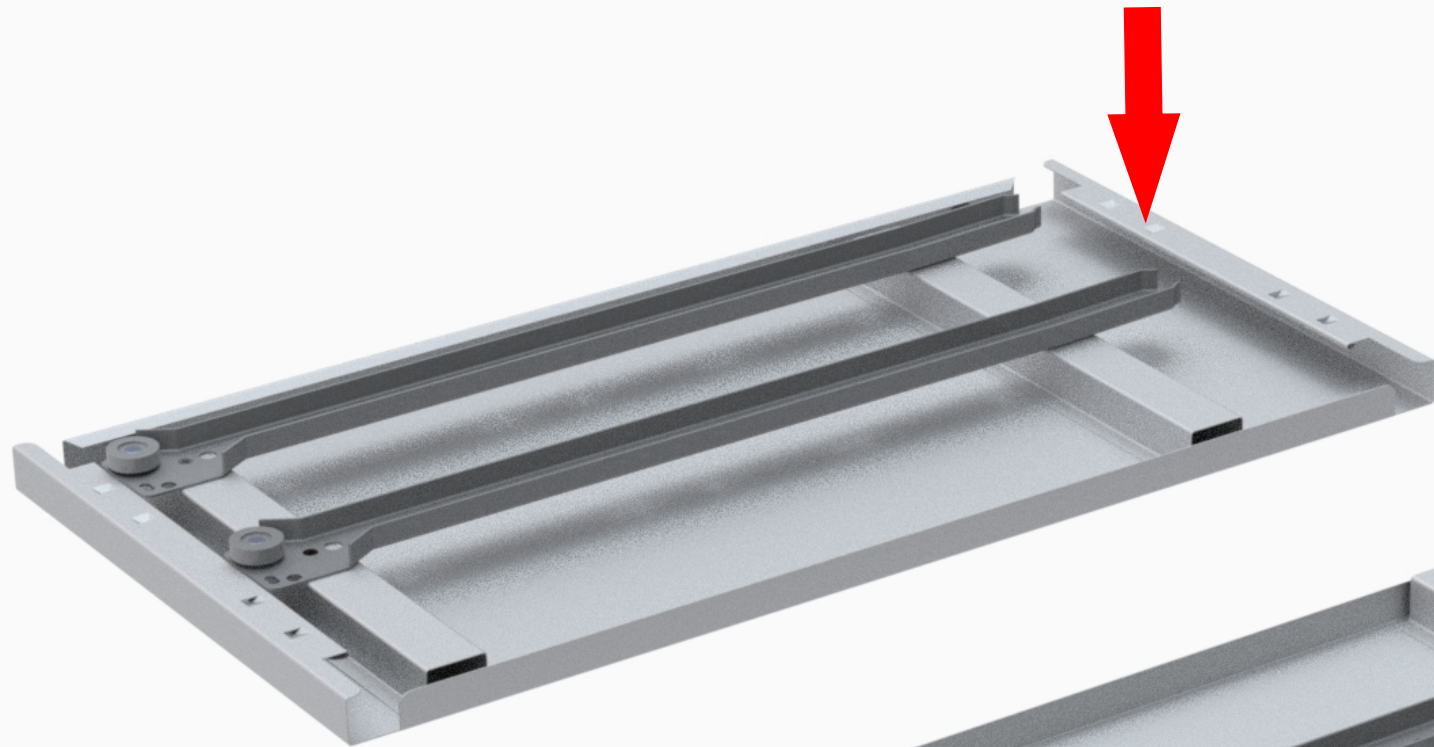

3x

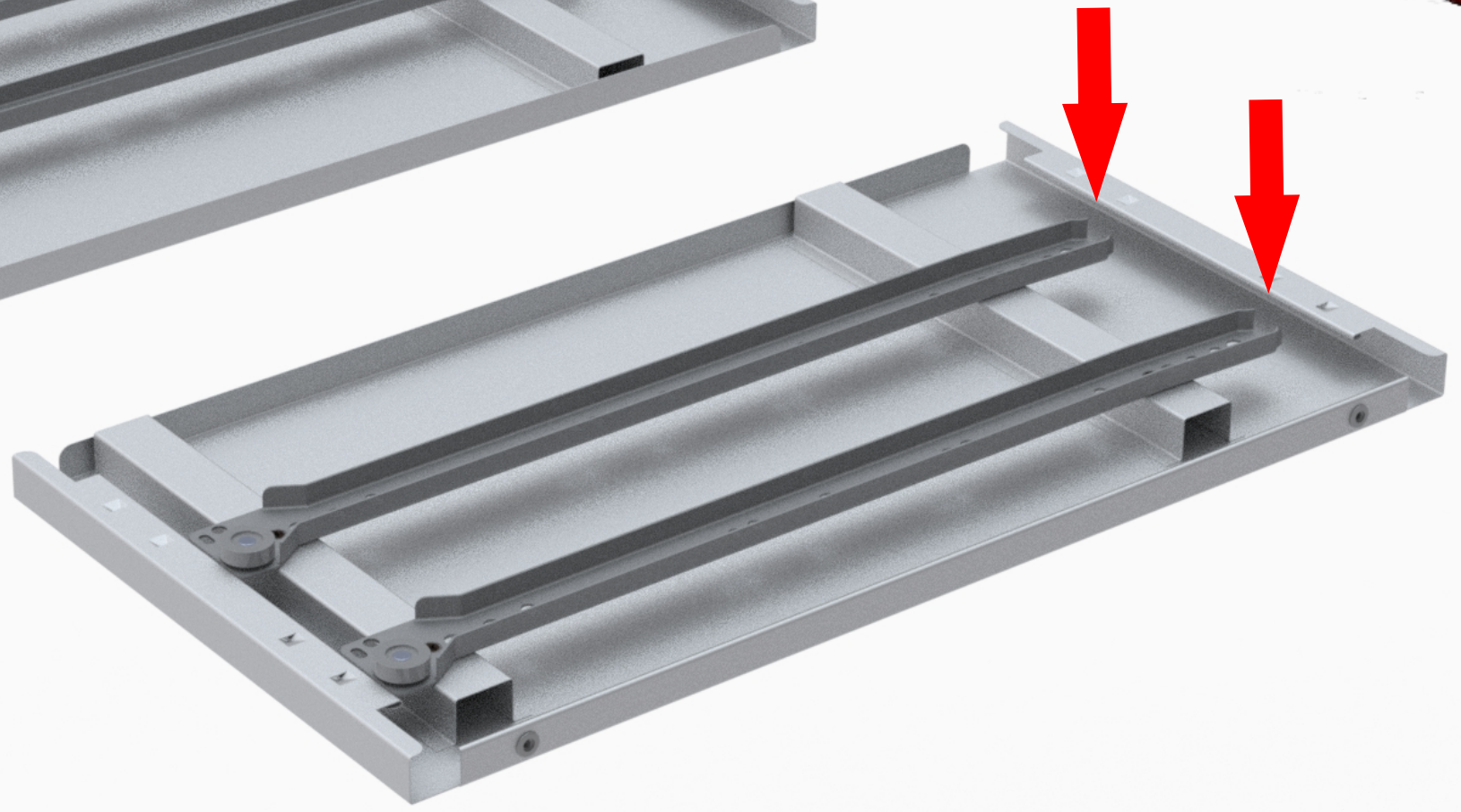

23° Passo

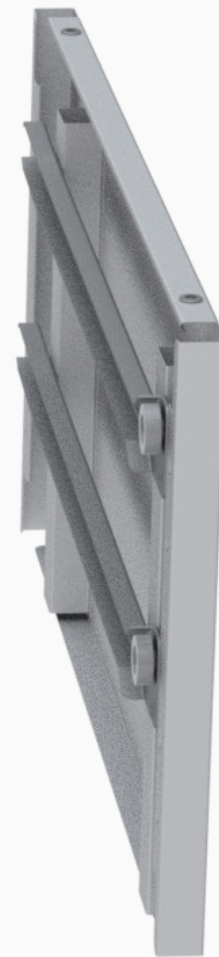

24° Passo

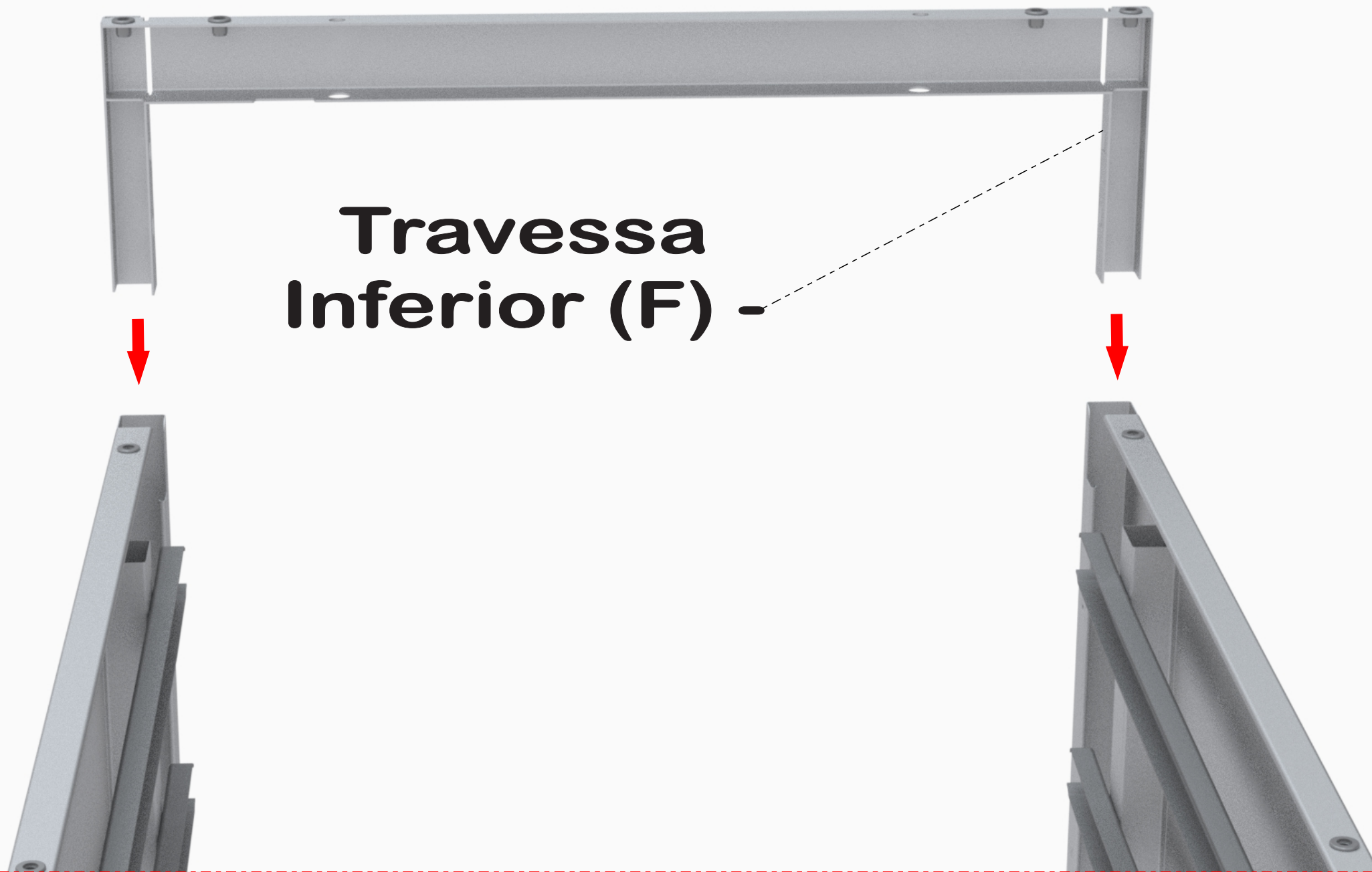

**Travessa
Inferior (F)**

Atenção: Travessa com Rebite

25° Passo

**Travessa
Inferior (F)**

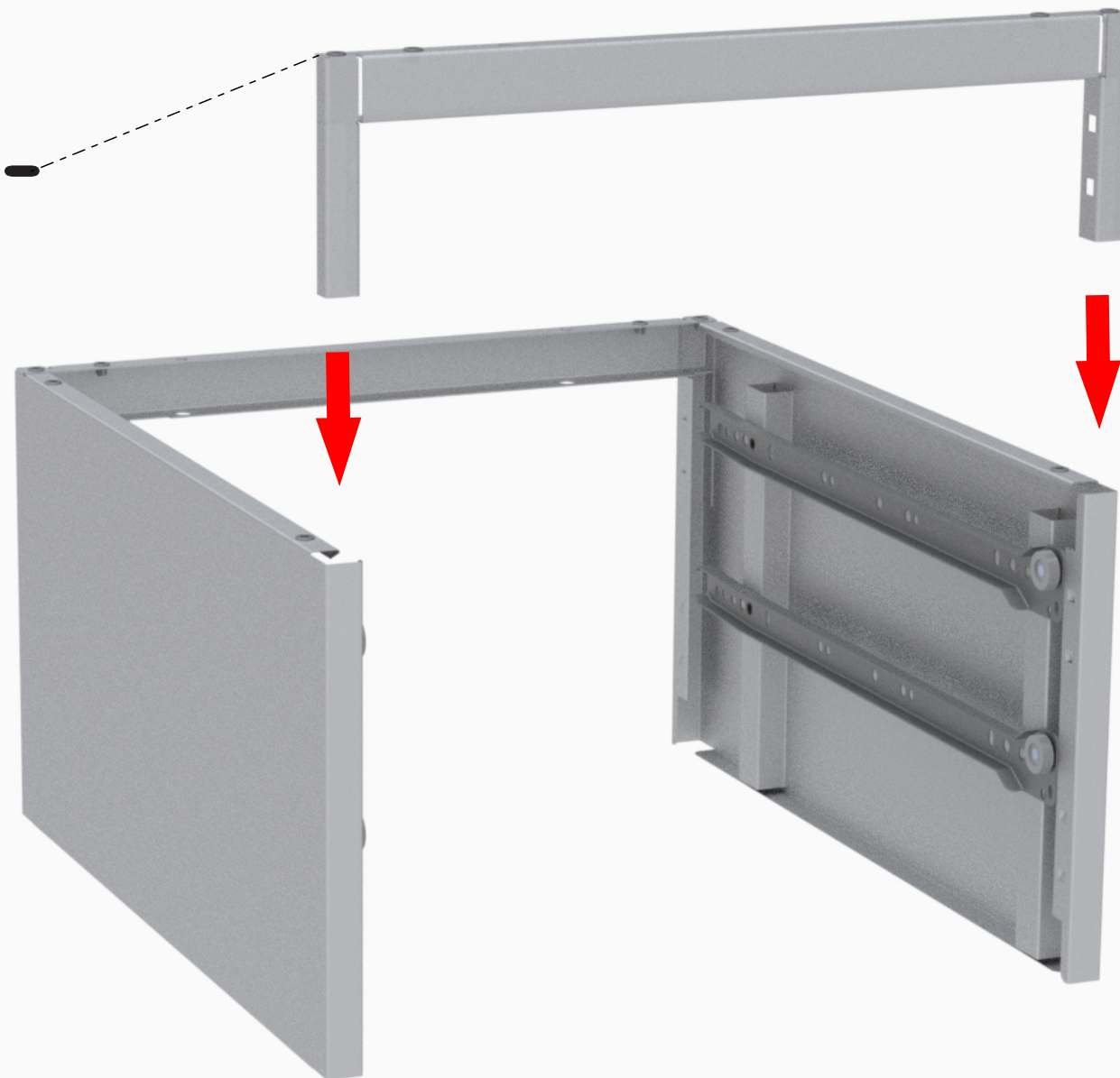

Atenção: Travessa com Rebite

26° Passo

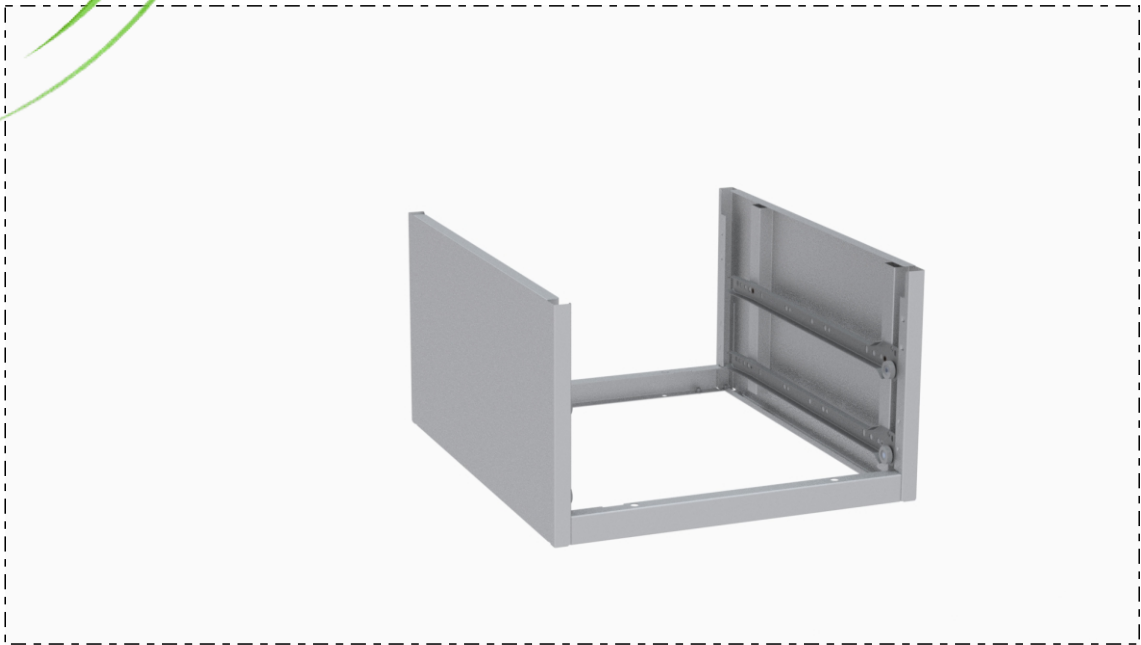
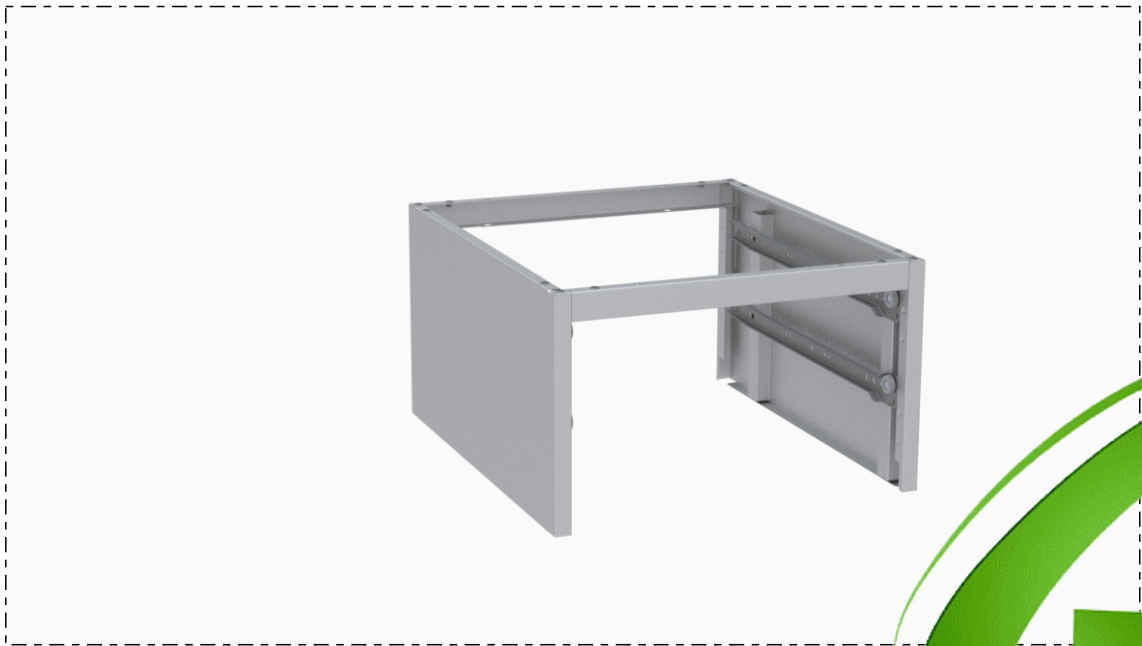

27° Passo



**Travessa
Superior (E)**

28° Passo

**Travessa
Superior (E)** -

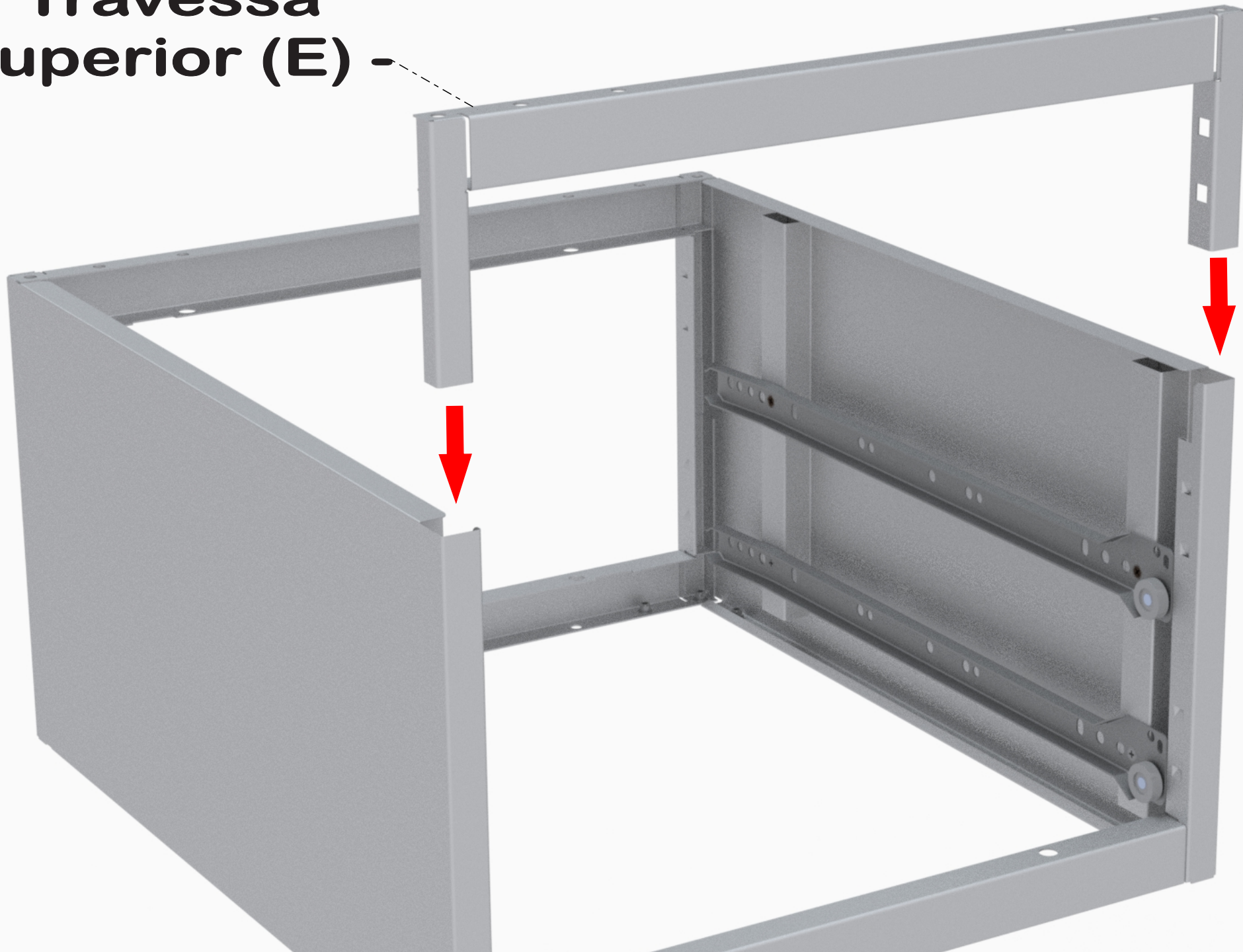

29° Passo

Suporte (10) -

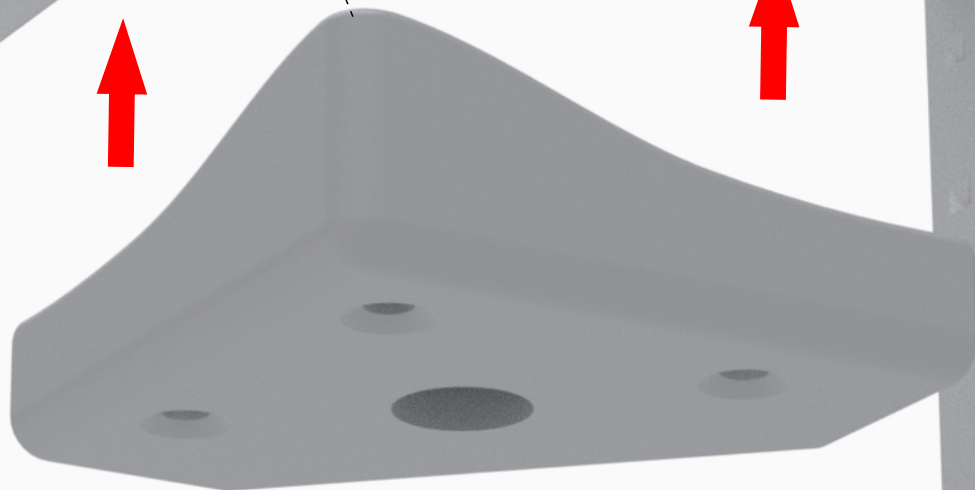

30° Passo

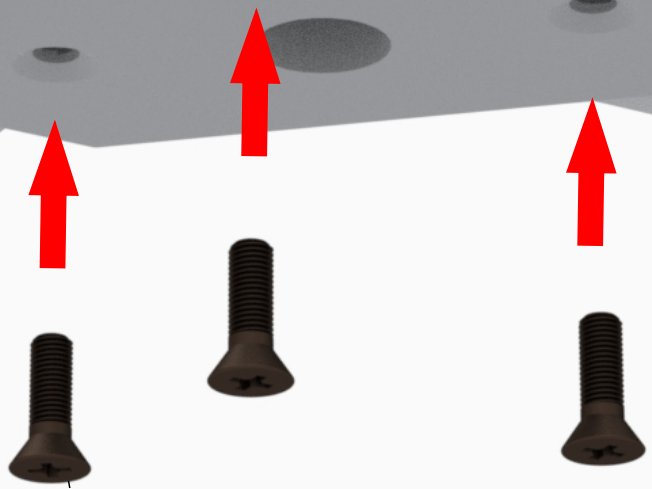

- Parafuso
6x10 (04)

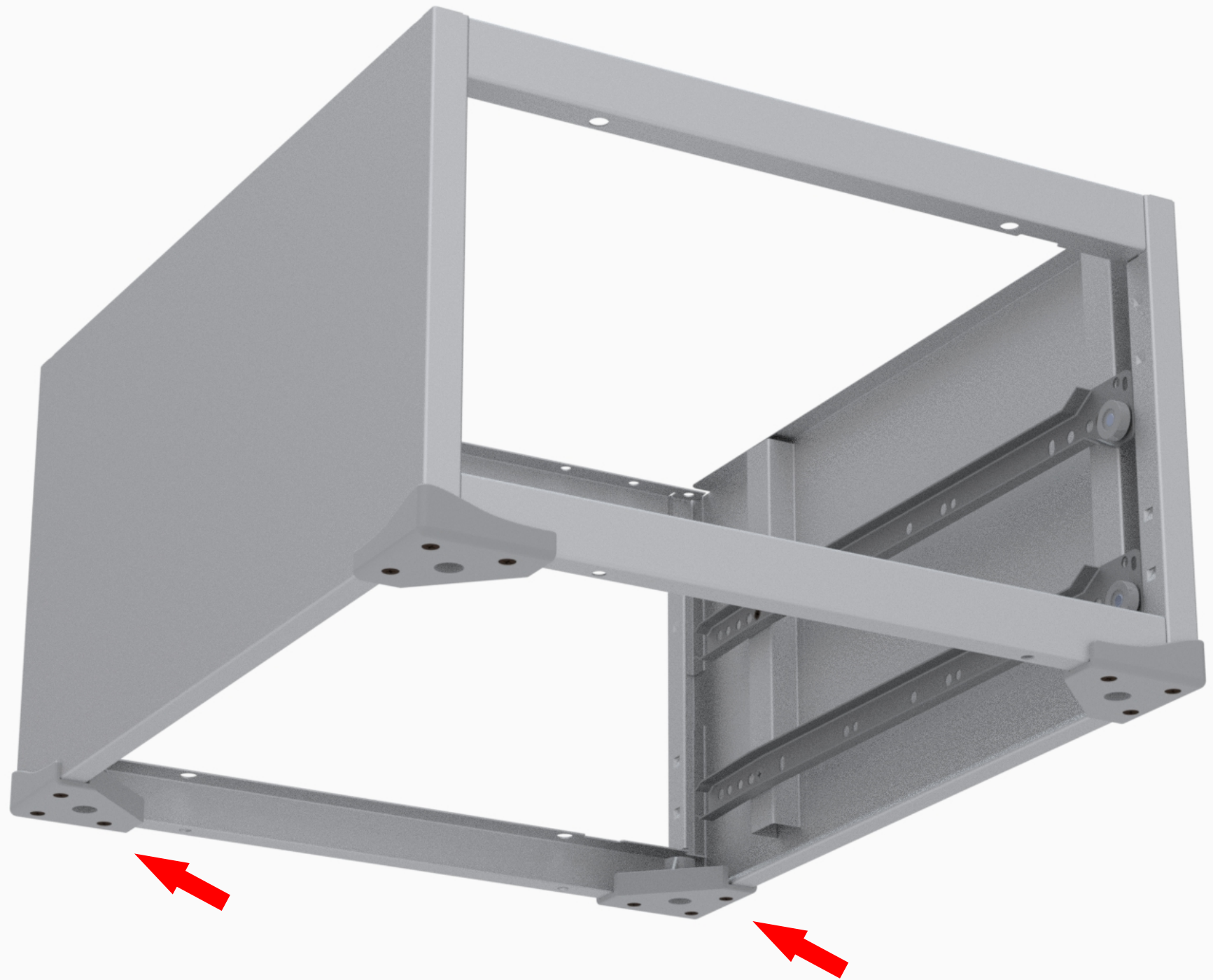

3x

32° Passo

32° Passo

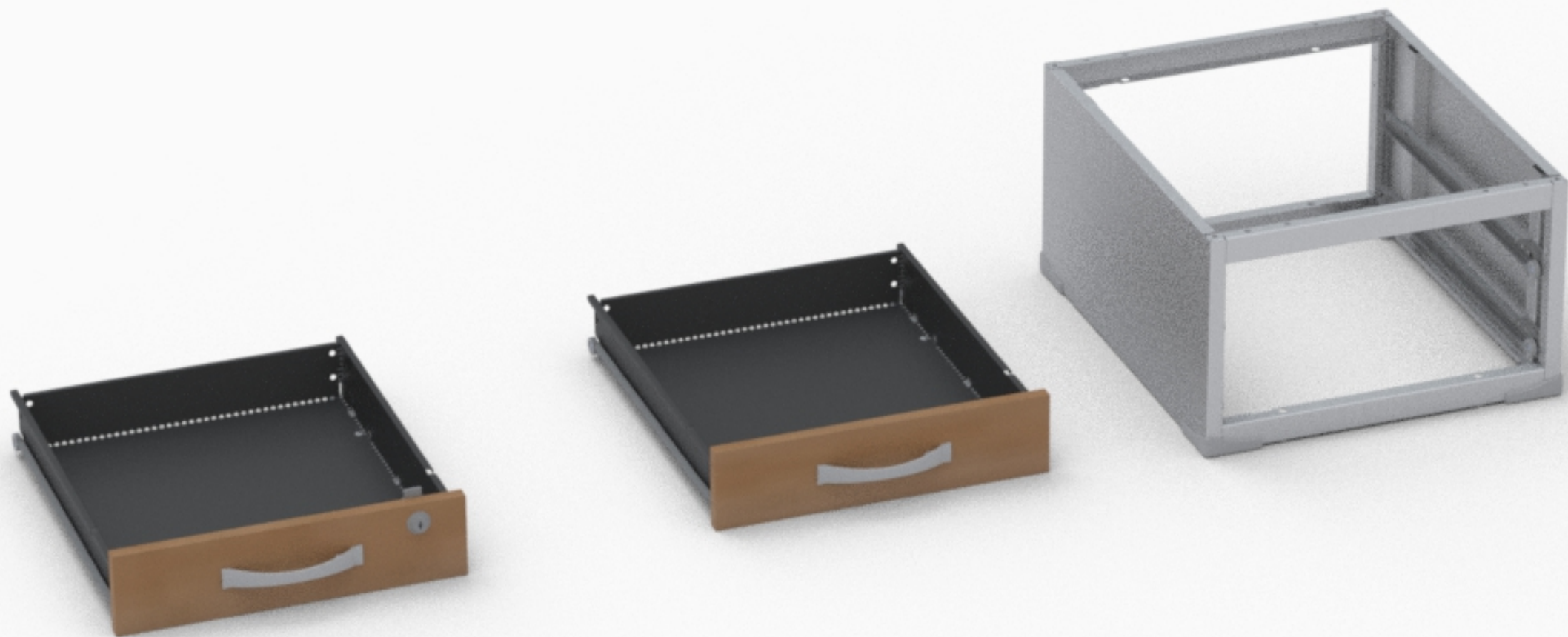

33° Passo

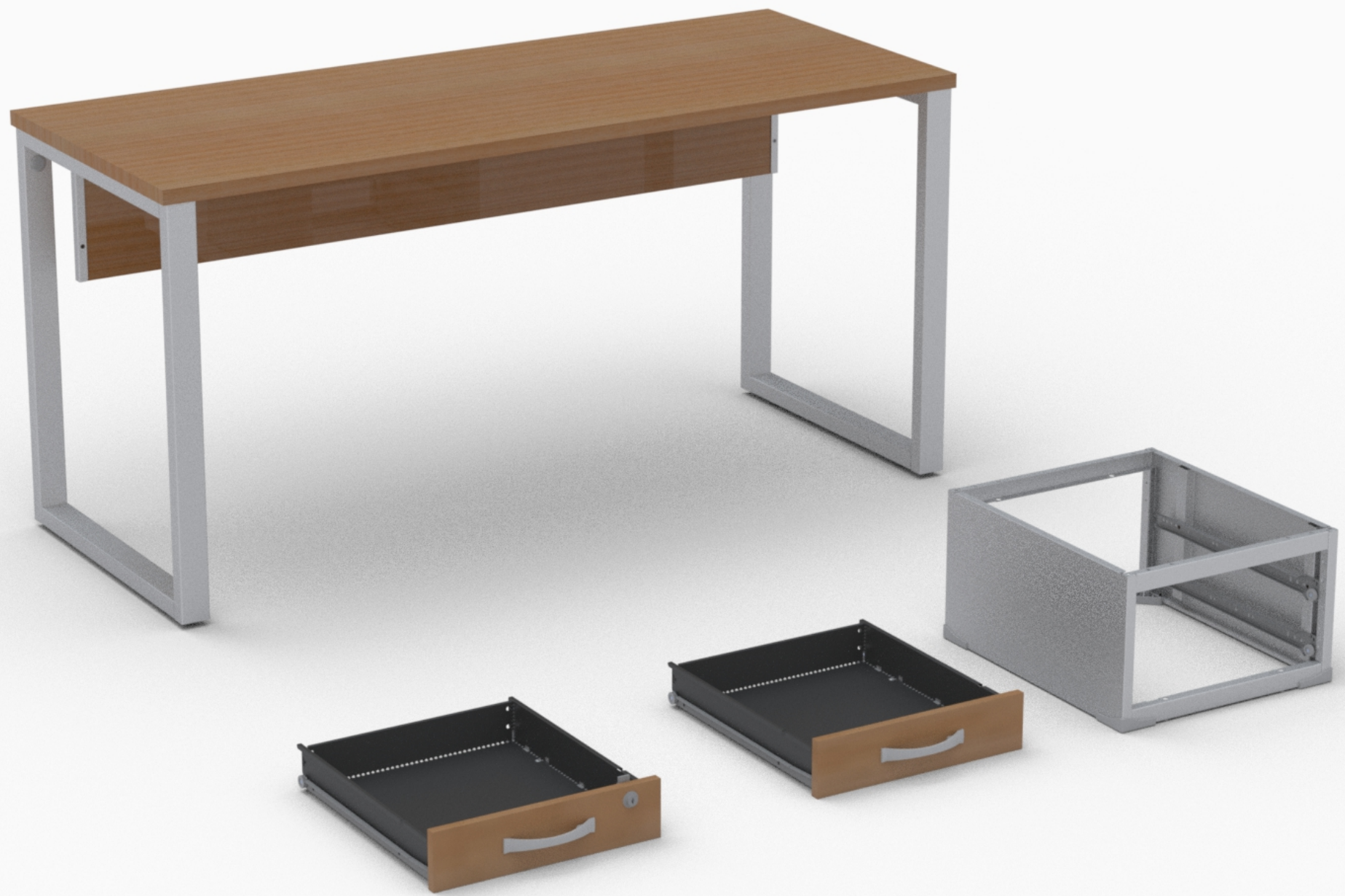

34° Passo

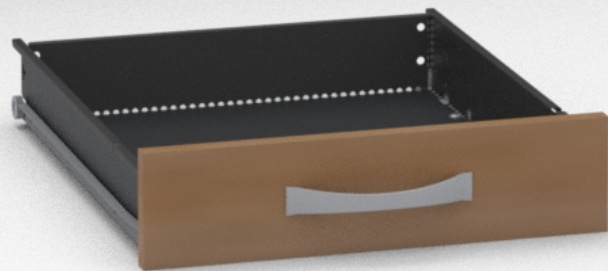
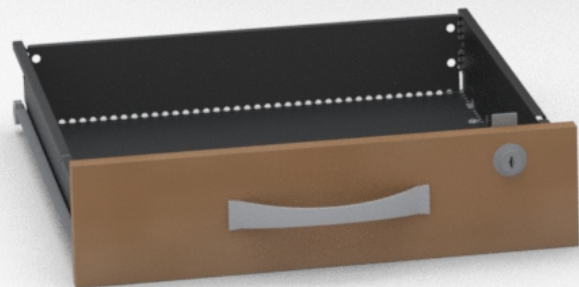
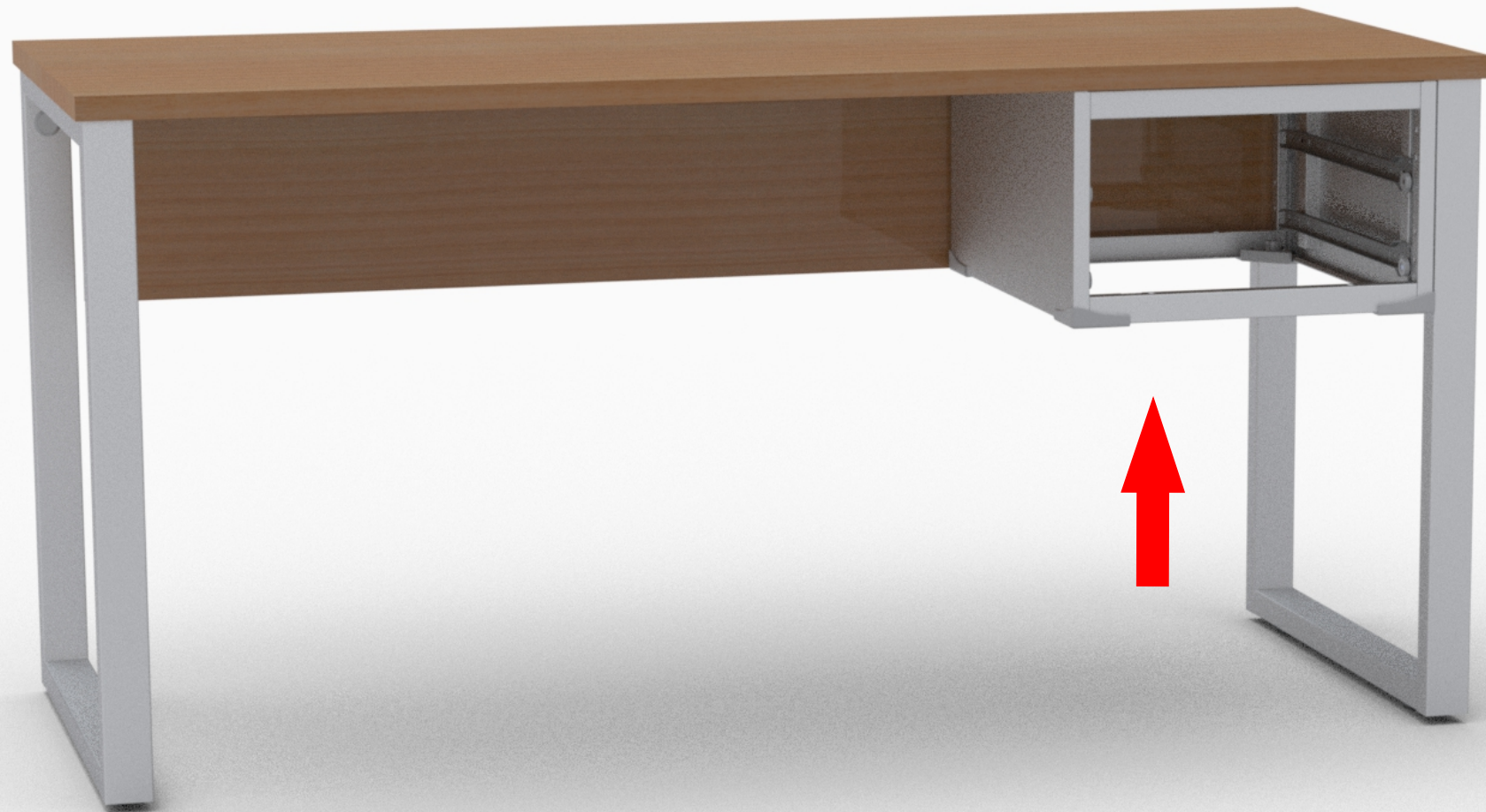

35° Passo

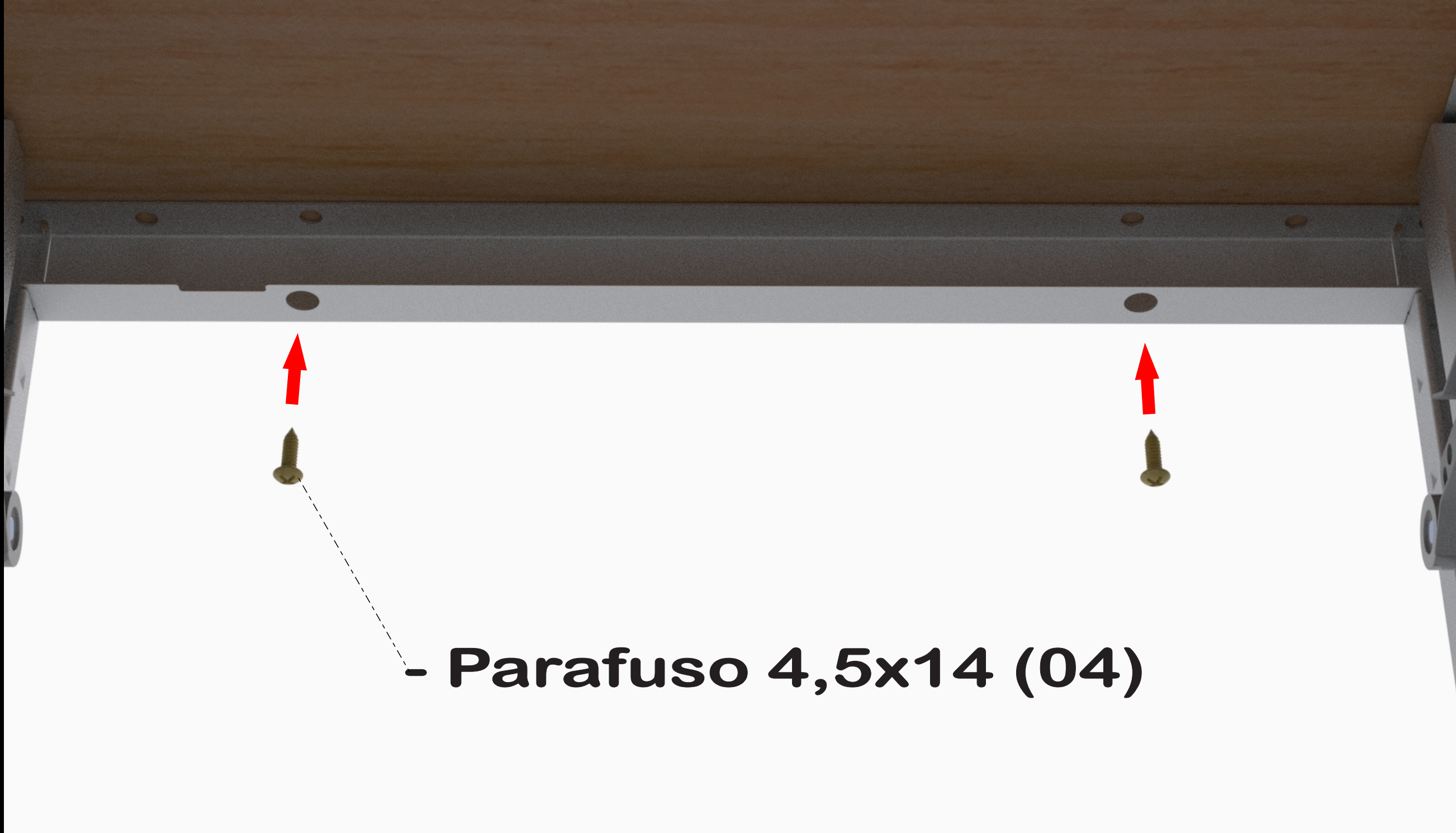

- Parafuso 4,5x14 (04)

36° Passo



- Parafuso 4,5x14 (04)

37° Passo



38° Passo



39° Passo



40° Passo

Instrução de Limpeza

PANDIN[®]
Soluções em Ambientes

Para produtos "MDF, MDP E MADEIRA (PEÇAS ENVERNIZADAS TINGIDAS, LAQUEADAS E COM PINTURA UV)"

- Para a limpeza utilize flanela seca ou pano macio, levemente umedecido com água. Utilize um pano seco em seguida;
- Evite contato com produtos químicos (solventes, thinner, acetona etc) e não utilize nenhum tipo de esponja de aço.

Para produtos "METALICOS"

- Para limpeza utilize flanela seca ou pano macio, levemente umedecido com água;
- Evite contato direto com objetos cortantes;
- Evite contato com produtos químicos e abrasivos (solventes, thinner, acetona etc) e não utilize nenhum tipo de esponja de aço;

GARANTIA

Aviso

- 1 - Nossos produtos possuem um prazo de garantia de 01 ano para defeitos de fabricação a partir da emissão da Nota Fiscal da fábrica, incluído os 90 dias determinados pelo Código de Defesa do Consumidor.**
- 2 - O prazo para troca de produtos avariados parcialmente ou inteiro, referente às peças de acabamentos sujeitas ao desgaste natural, ficarão restritas ao prazo legal de 90 dias a partir da emissão da Nota Fiscal.**
- 3 - A empresa somente fará a reposição de partes e componentes dos produtos nos termos discriminados abaixo e que comprovarem a existência do alegado defeito de material ou fabricação.**
- 4 - A garantia é válida para defeitos de fabricação detectados por via e-mail, pelo site “Alô Pandin” ou pela Central de Atendimento (telefone na Etiqueta) e toma-se nula quando:**
 - Problemas ocorridos por montagem em desacordo com o manual de instrução ou relacionados a adaptações ou alterações realizadas no produto;**
 - Defeitos e desgaste no acabamento, partes e/ou peças ocorridos por uso intenso ou exposição a condições adversas e não previstas, tais como umidade excessiva, intempéries, maresia, frio e calor intensos, cupim e pragas de madeira em geral, sinistros, acidentes, quedas ou agentes da natureza;**
 - Problemas ocorridos devido as condições inadequadas do local de instalação do produto, tais como pisos desnivelados, paredes pouco resistentes e fora do prumo, etc;**
 - Danos causados por serviços ou consertos contratados pelo consumidor, descuido, maus tratos, limpeza e/ou manutenção em desacordo com as instruções contidas no manual;**
- 5 - Todas as reclamações e defeitos observados durante o prazo da garantia serão atendidos mediante a apresentação da nota fiscal de compra e entrando em contato com nossa central de atendimento.**
- 6 - A empresa reserva-se o direito de alterar as características gerais, técnica e estética, introduzir melhoramentos a sua linha de produtos em qualquer momento, sem incorrer na obrigação de efetuar o mesmo nos produtos em estoque ou já vendidos.**
- 7 - Em caso de troca total do produto ou de peças, a empresa efetuará o envio do mesmo após comprovação da empresa.**

Rede Sociais

*Siga-nos nas Redes Sociais
aperte sobre a imagem*

PANDIN[®]

Soluções em Ambientes



/pandinoficial



WhatsApp SAC



@pandinmoveis



PandinOfficial