



**MANUAL DE MONTAGEM
ASSEMBLY INSTRUCTIONS
INSTRUCCIONES DE MONTAJE**

COD BR: BL 63-06, BMU 63-06, BBN 63-06

Sumário Summary Resumen

Introdução Introduction Introducción	3
Antes de começar Before starting Antes de comenzar	4
Evite acidentes Avoid accidents Evitar accidentes	4
Dimensões e ferramentas Dimensions and tools Dimensiones y herramientas	5
Identificação das peças Identifying parts Identificación de las piezas	6
Acessórios incluídos na caixa Hardware included in box Accesorios incluidos en la caja	7
Montagem do móvel Furniture assembly Montaje del mueble	8

Introdução Introduction Introducción

Leia atentamente este manual e siga os passos indicados para uma perfeita montagem.
Read this manual and follow the steps for the perfect fit.
Lea este manual y siga los pasos para el ajuste perfecto.

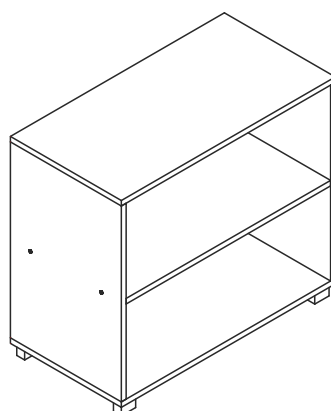

Antes de começar Before starting Antes de comenzar

Antes de começar a montagem prepare o ambiente, deixando-o completamente limpo e com bom espaço para iniciar o trabalho.

Prepare the room before starting the assembly, leaving it completely clean and the area in good condition to start the work.

Antes de comenzar el montaje preparar el ambiente, dejándolo completamente limpio y con bueno espacio para comenzar el trabajo.

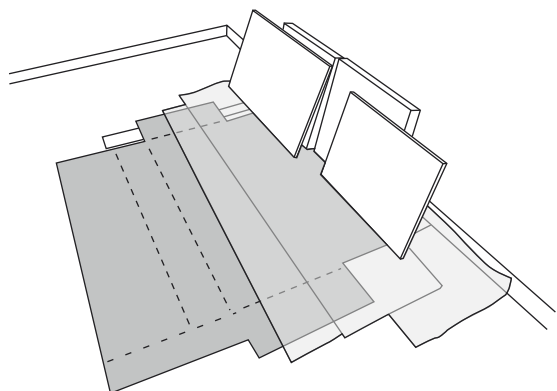

Utilize o papelão da própria embalagem para separar e apoiar as peças retiradas das caixas.

Use the cardboard of the packaging to separate and support the parts removed from the boxes.

Utilice el cartón de la embalaje para separar y apoyar las piezas desmontadas de las cajas.

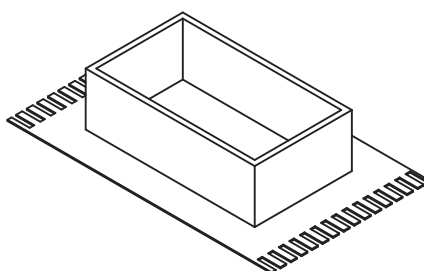

Forre a área de montagem com um cobertor ou tapete. Assim, você evita avarias nas peças durante o processo de montagem.

Cover the assembly area with a blanket or carpet to avoid damaging the parts during the assembly process.

Cubrir la zona de ensamble con una manta o alfombra. De este modo, se evitan daños en las piezas durante el proceso de montaje.



Evite acidentes Avoid accidents Prevenir accidentes

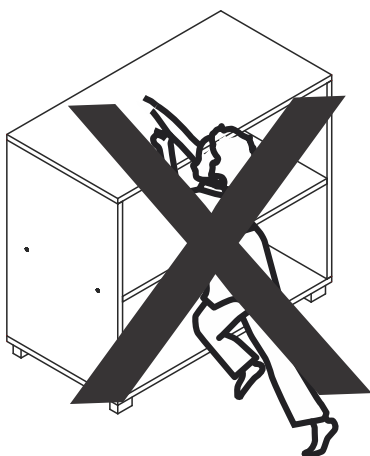

Não escale ou se apoie no móvel.

Do not climb or lean on the furniture.

No se suba ni se apoye en el mueble.

Dimensões e ferramentas
Dimensions and tools
Dimensiones y herramientas

Dimensões:

L: 675 A:605 P: 350 mm

Dimensions:

W: 26.57 H: 23.81 D: 13.78 inches

Dimensiones:

L: 675 A: 605 P: 350 mm

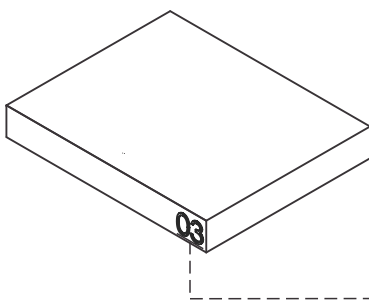
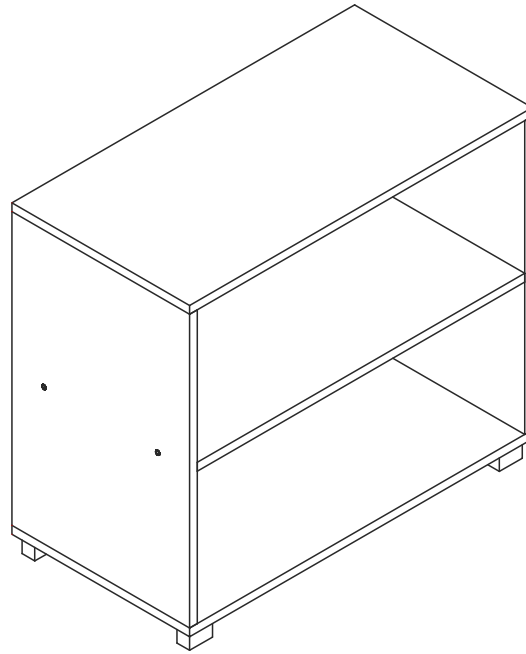

UTILIZE ALCOOL PARA REMOVER O NUMERO DAS PEÇAS
USE ALCOHOL TO REMOVE PART NUMBERS
UTILICE ALCOHOL PARA ELIMINAR EL NUMERO DE LAS PIEZAS

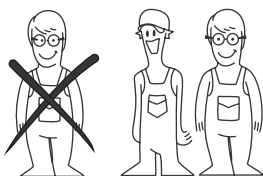

Para facilitar a montagem, utilize uma parafusadeira elétrica.
To improve assembly, use an electronic screwdriver.
Para facilitar el armado, utilice un destornillador eléctrico.

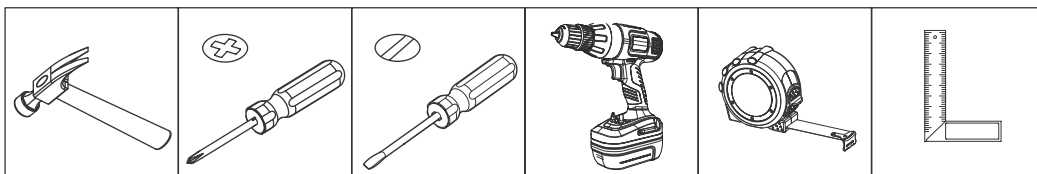

COD BR: BL 63-06, BMU 63-06, BBN 63-06

PEÇA	DESCRIÇÃO	QUANT.	PART DESCRIPTION	QTY	PIEZA	DESCRIPCIÓN	CANTIDAD
001	BASE	1	001	BASE	001	BASE	1
002	TAMPO	1	002	TOP	002	TAPA	2
003	LATERAL	2	003	SIDE	003	SIDE	1
004	PRATELEIRA	1	004	SHELF	004	SHELF	2
005	COSTAS	2	005	BACK			

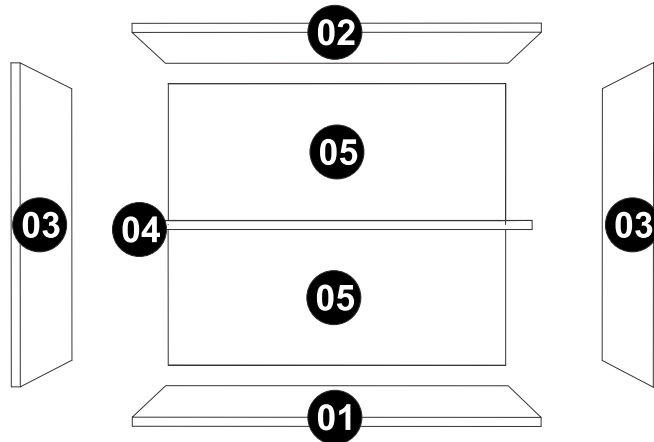



PÉS x 4
FEET x 4
PIES x 4



EF 000404 x 8
3,5X25 CC



TAPA FUROS x 4
STICKERx 4
TAPAS PLASTICASx 4



EF 000033 x 12
8x30

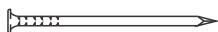

EF 000168 X 40



EF 000132 x 8
4x50 CC



EF 000008 X 1



GIZ x 01
CHALK x 01
TIZA x 01

Utilize para medir as ferragens.

Utilice para medir el herraje.

Use for measuring the hardware.

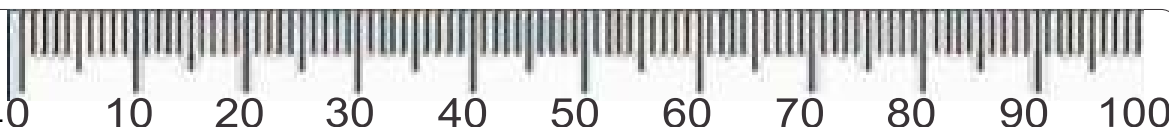

Garantia (exclusivo para o Brasil/exclusivo de Brasil/exclusive to Brazil):

A garantia dos produtos fabricados pela BRV Móveis, abrange eventuais defeitos-vícios de fabricação, no prazo estabelecido pelo código de Defesa do Consumidor, em seu artigo 26.II. o qual prevê a garantia de 90 (noventa) dias.

A = 8KG - 17.63LB

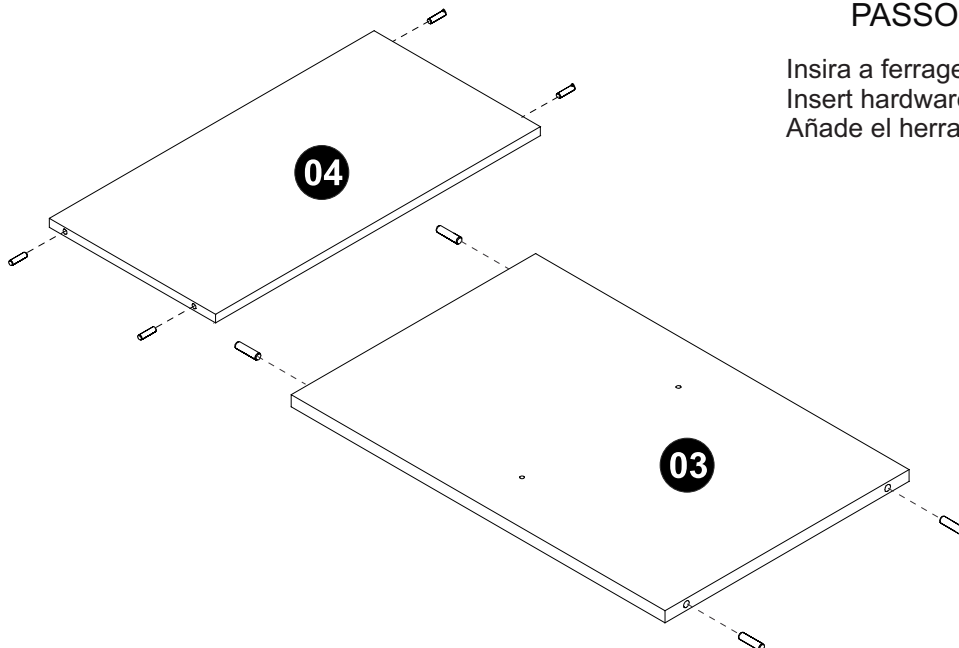
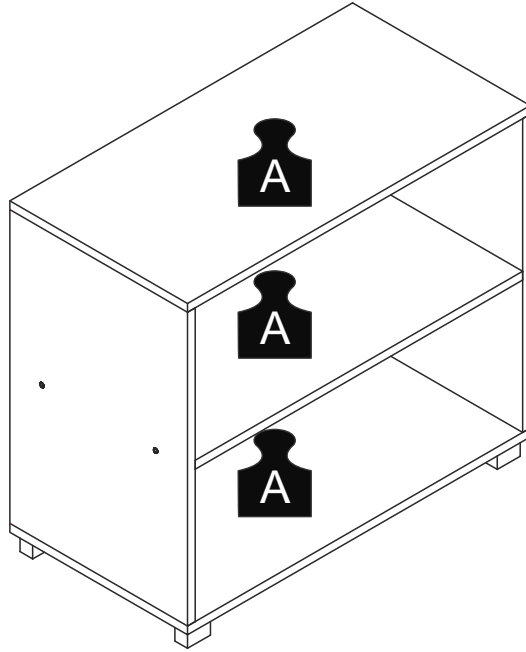

PASSO 1 / STEP 1 / PASO 1

Insira a ferragem EF 000033 nas peças 03 e 04.
Insert hardware EF 000033 into pieces 03 and 04.
Añade el herraje EF 000033 en las piezas 03 y 04.

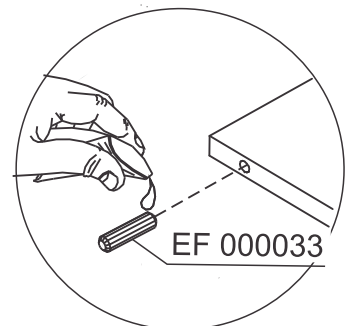

PASSO 2 / STEP 2 / PASO 2

Use a ferragem EF 000132 para conectar as peças 03 e 04.
Use hardware EF 000132 to connect pieces 03 and 04.
Utilice el herraje EF 000132 para juntar las piezas 03 y 04.

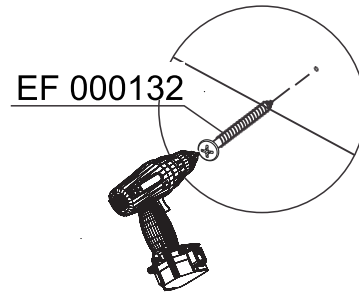
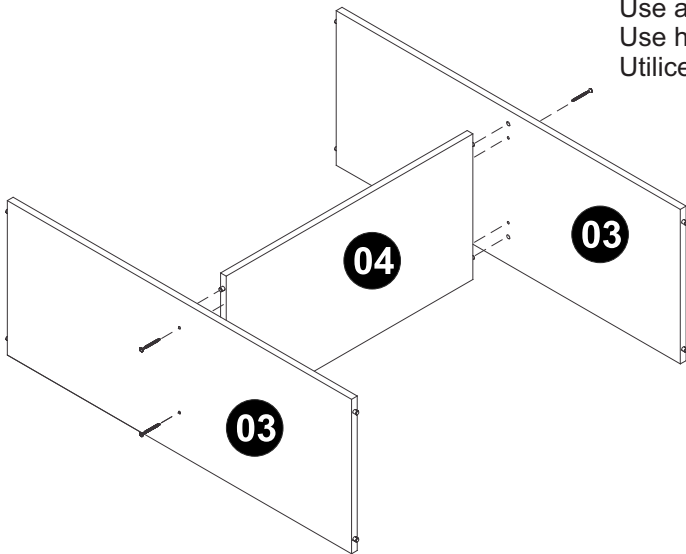

PASSO 3 / STEP 3 / PASO 3

Utilize a cola para conectar a peça 02, fixe a peça 01 utilizando a ferragem EF 000132.
Use the glue to connect piece 02, attach piece 01 using hardware EF 000132.
Use el pegamento para fijar la pieza 02, fije la pieza 01 utilizando el herraje EF 000132.

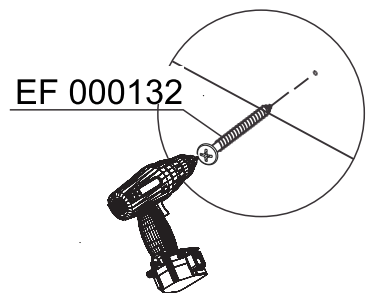
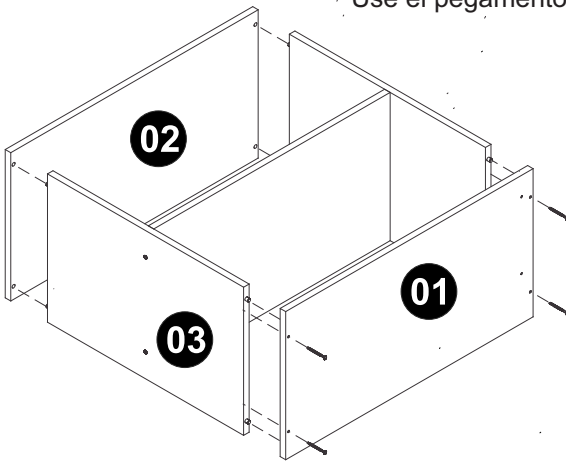

PASSO 4 / STEP 4/ PASO 4

Fixe os pés na peça 01 utilizando a ferragem EF 000404
Fix the feet at piece 01 using hardware EF 000404 .
Fije los pies en la pieza 01 utilizando el herraje EF 000404.

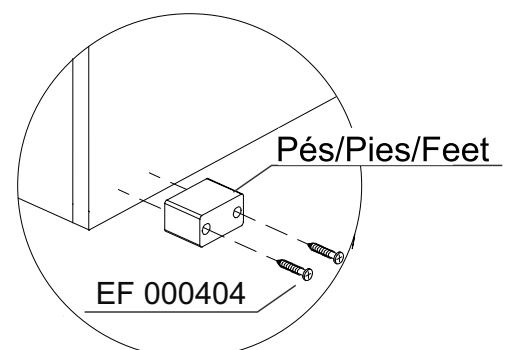
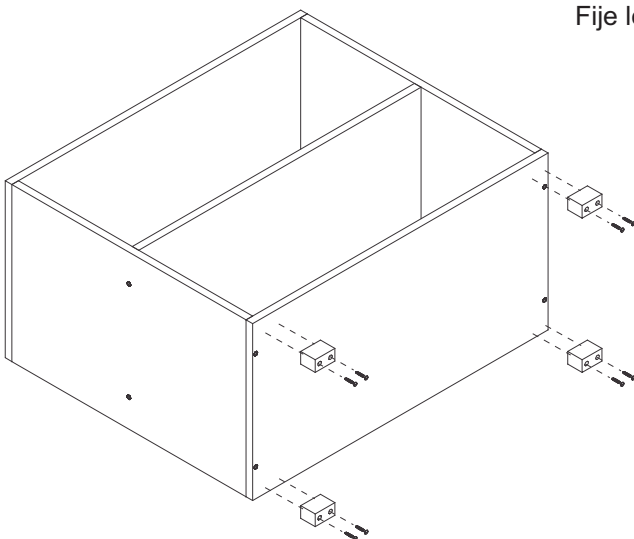

PASSO 5 / STEP 5 / PASO 5

Fixe as peças 05 utilizando a ferragem EF 000168.
Attach pieces 05 using hardware EF 000168.
Fije las pezas 05 utilizando el herraje EF 000168.

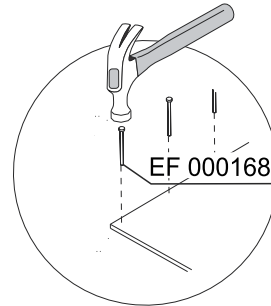
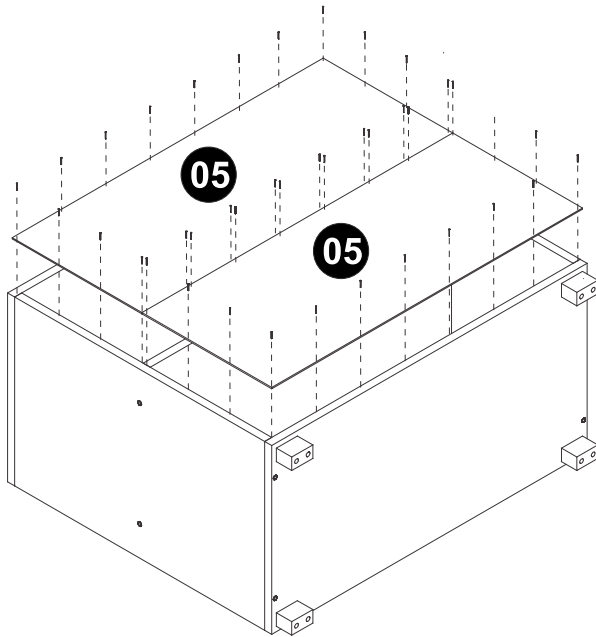

PASSO 6 / STEP 6 / PASO 6

Utilize o tapa furos para cobrir os parafusos aparentes.
Use the sticker to cover the apparent screws.
Utilice los tapa huecos para cubrir los tornillos aparentes.

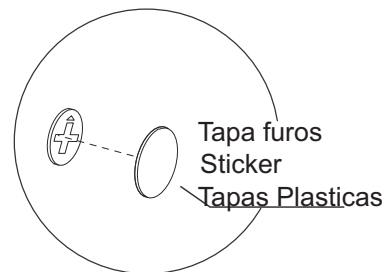
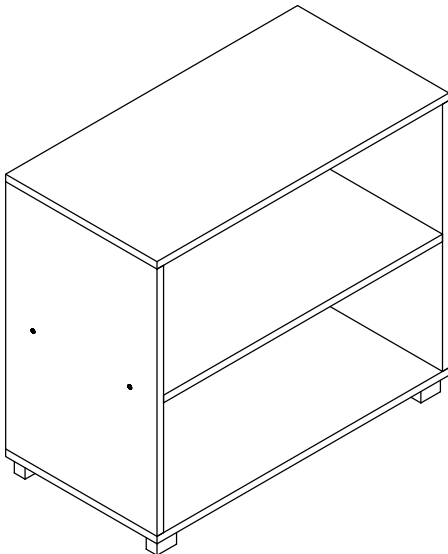

PASSO 7 / STEP 7 / PASO 7

Use o giz para dar o acabamento final ao produto.
Use the chalk to give the final finish on the product.
Utilice la tiza para dar el acabado final al producto.

