

Dicas de Conservação / Maintenance Tips / Dicas  
para Conservación

\*Para limpar ou tirar manchas, utilize uma flanela umedecida em solução de água e álcool, na mesma proporção.

\*Evite exposição ao sol.

\*To clean or remove stains, use a piece of flannel dampened with a water and alcohol solution, in the same proportion.

\*Avoid direct sunlight.

\*Para limpiar o sacar manchas, utilice una flanela humedecida en solución de agua y alcohol, en la misma proporción.

\*Evite la exposición directa al sol.

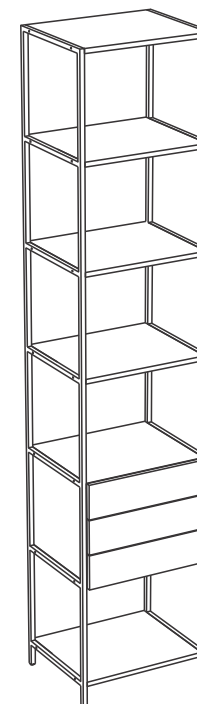





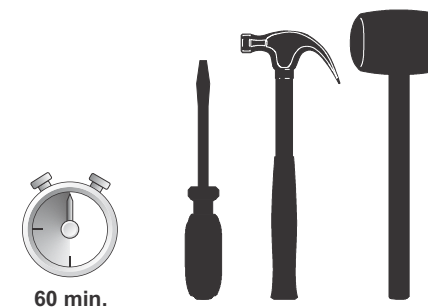
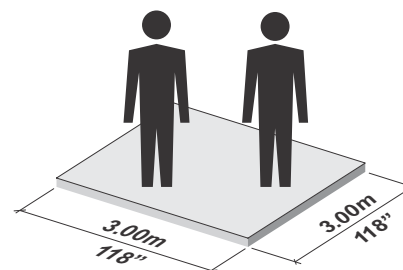





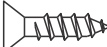

**INSTRUÇÕES DE MONTAGEM**  
**ASSEMBLING INSTRUCTIONS / INSTRUCCIONES DE MONTAJE**

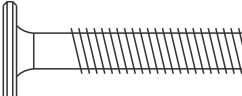
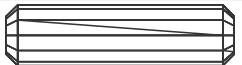
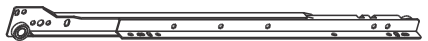
**ARTESANO MÓVEIS LTDA.**  
ROD. BR - 470, KM 207,330 n° 9653, Bairro São Valentim  
CEP 95709-340 - Bento Gonçalves - RS - Brasil  
Fone: +55 54 3458 3400  
e-mail: [artesano@artesano.com.br](mailto:artesano@artesano.com.br)  
[www.artesano.com.br](http://www.artesano.com.br)



**FERRAGENS  
HARDWARE LIST  
LISTA DE MATERIALES**

<b>A</b>			4,5 x 60mm	<b>28</b>
<b>B</b>			4 x 12mm	<b>24</b>
<b>C</b>			6 x 8mm	<b>12</b>
<b>D</b>			1/4" x 30mm	<b>04</b>
<b>E</b>			8 x 30mm	<b>28</b>
<b>F</b>			300mm	<b>03</b>
<b>G</b>			300mm	<b>03</b>
<b>H</b>			8 x 8mm	<b>21</b>
<b>I</b>				<b>04</b>
<b>J</b>				<b>06</b>
<b>K</b>			4,5 x 45mm	<b>06</b>

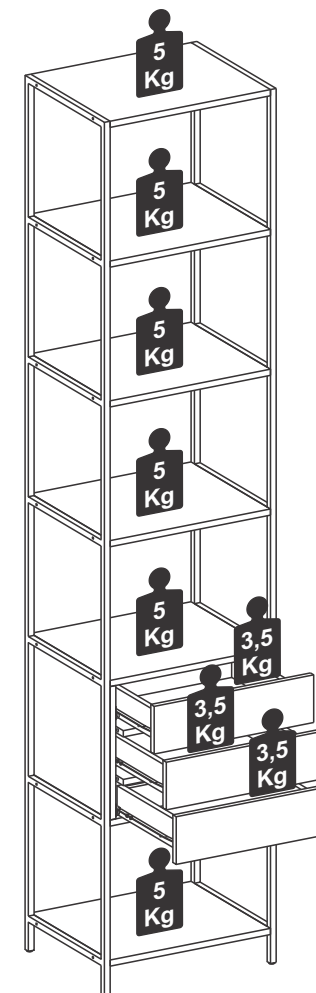

MONTE O MÓVEL COMO NÓS O PRODUZIMOS: COM CARINHO.

ASSEMBLE THE FURNITURE AS WE PRODUCE IT: WITH LOVE.

MONTE EL MUEBLE COMO NOSOTROS LO PRODUCIMOS: CON CARÍÑO.

**7** Passo  
Step  
Paso **3x**

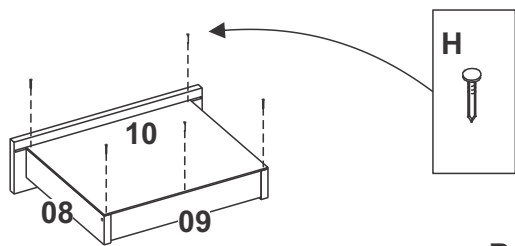

**8** Passo  
Step  
Paso **3x**

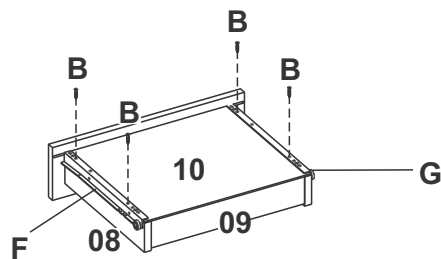

**9** Passo  
Step  
Paso

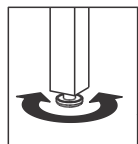
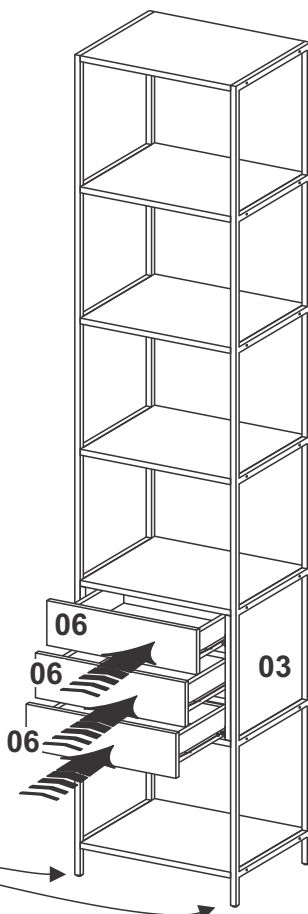

10

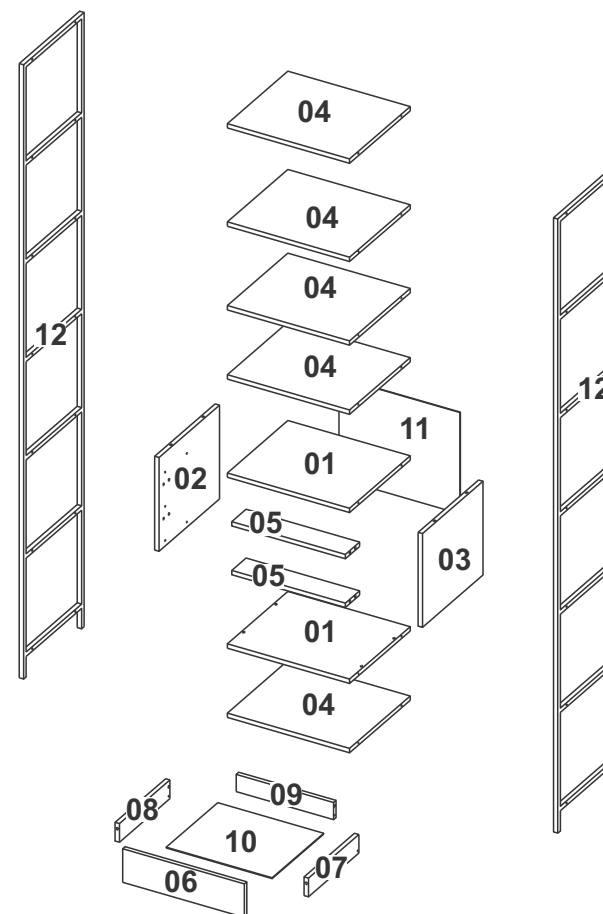

Denominação Description Denominación	Qtde Qty Ctd	Dimensão Dimension Dimensión
01 - Tampo / Top / Tapa	02	420x358x15
02 - Lateral Esquerda / Left Side / Lateral Izquierda	01	322x358x15
03 - Lateral Direita / Right Side / Lateral Derecha	01	322x358x15
04 - Prateleira Menor / Small Shelf / Estante Menor	05	420x358x15
05 - Travessa / Crosbar / Tarvesaño	02	390x85x15
06 - Frente Gaveta / Front Drawer / Frente Cajón	03	115x418x15
07 - Lateral Direita Gaveta / Right Drawer / Lateral Derecha Cajón	03	300x64x15
08 - Lateral Esquerda Gaveta / Left Drawer / Lateral Izquierda Cajón	03	300x64x15
09 - Fundo Gaveta / Back Drawer / Revés Cajón	03	334x59x15
10 - Fundo Gaveta / Bottom Drawer / Fonfo Cajón	03	364x306x3
11 - Costa / Back / Revés	01	416x348x3
12 - Lateral Metálica / Metallic Side / Lateral Metalica	02	2110x360x15

3

**ETAPA DE PREPARAÇÃO DAS PEÇAS.  
STAGE OF PREPARATION OF THE PIECES.  
FASE DE PREPARACIÓN DE LAS PIEZAS.**

**PREPARE TODAS AS PEÇAS ANTES DE INICIAR A MONTAGEM.  
PREPARE ALL THE PIECES BEFORE BEGINNING THE ASSEMBLY.  
PREPARAR TODAS LAS PIEZAS ANTES DE INICIAR EL MONTAJE.**

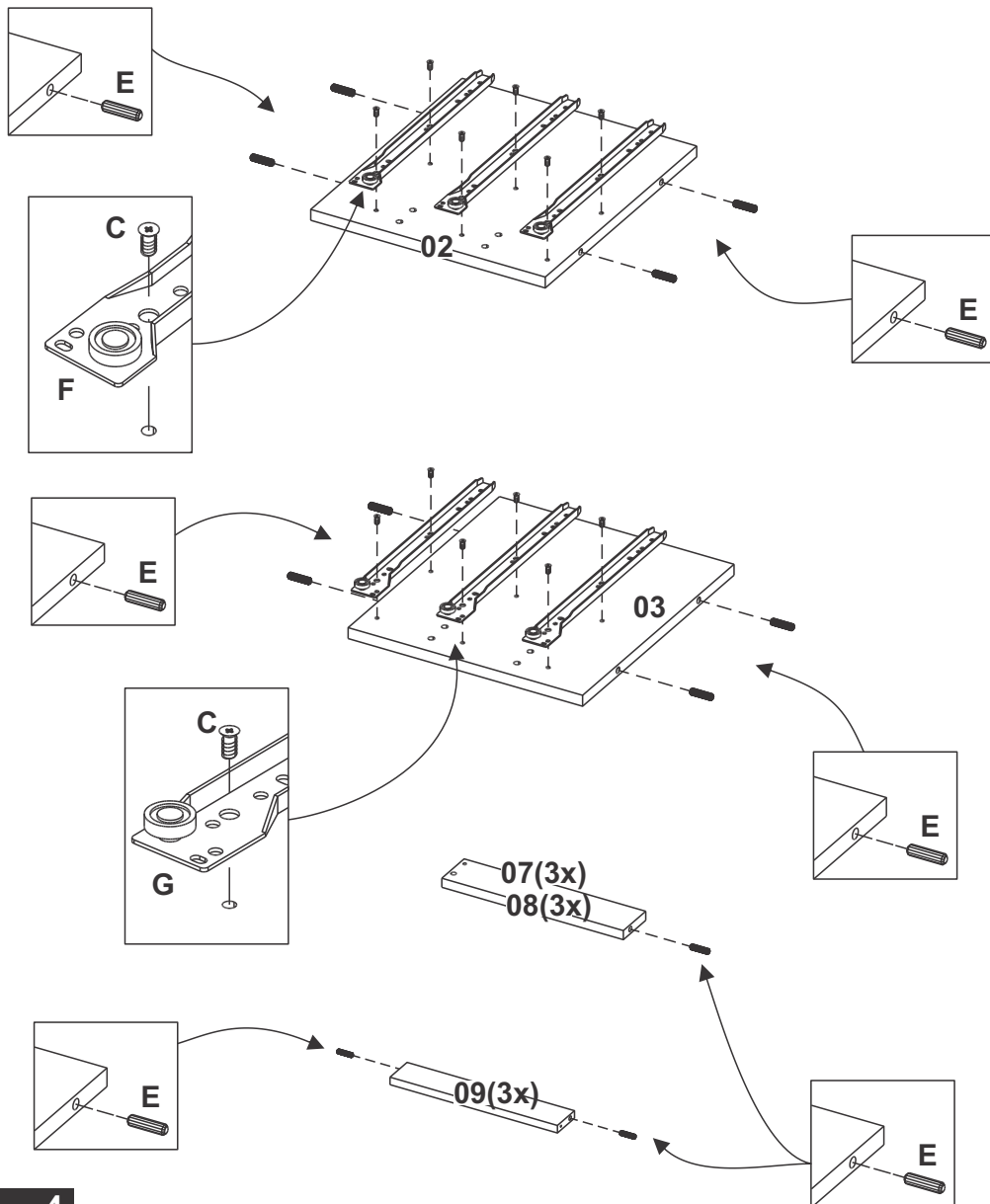

**5** Passo Step Paso **3x**

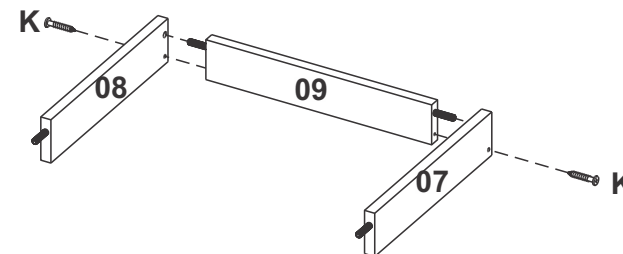

**6** Passo Step Paso **3x**

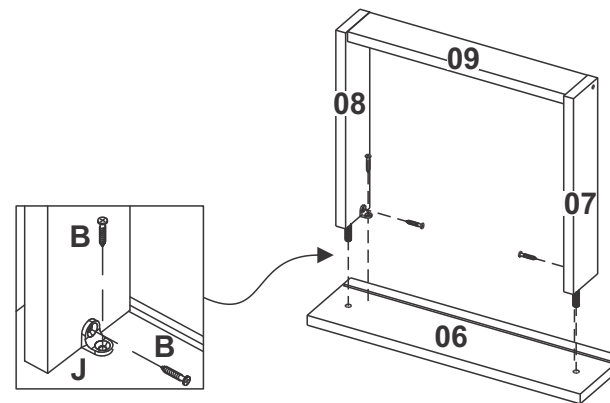

**4** Passo  
Step  
Paso

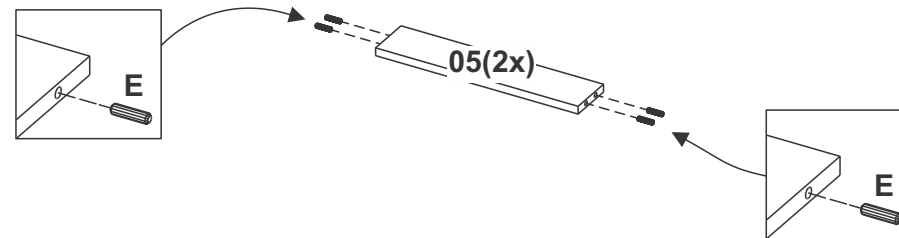
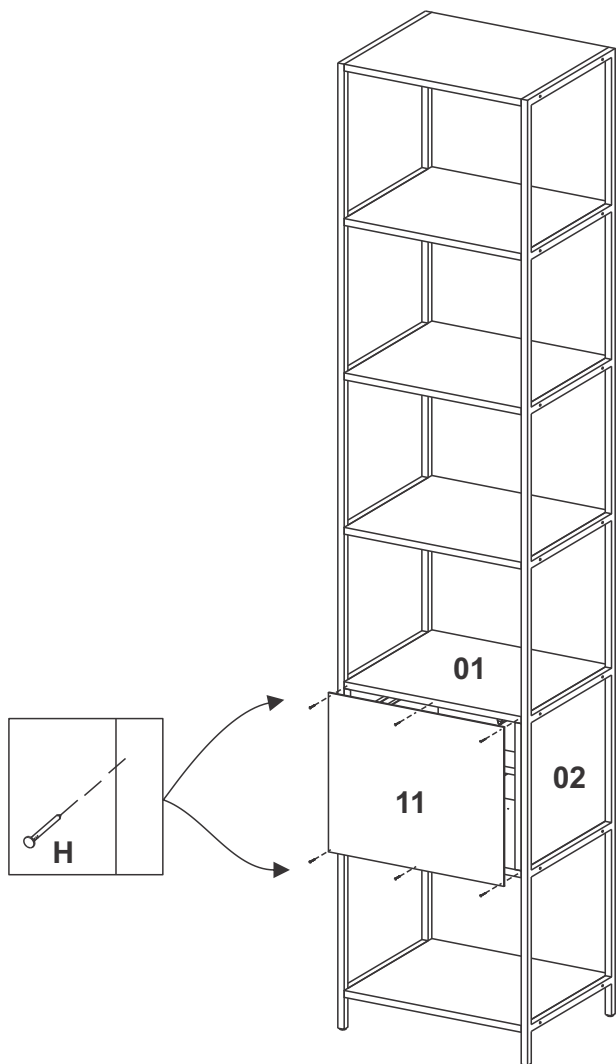

**ETAPA DE MONTAGEM.  
STAGE OF ASSEMBLY.  
FASE DE MONTAJE.**

**1** Passo  
Step  
Paso

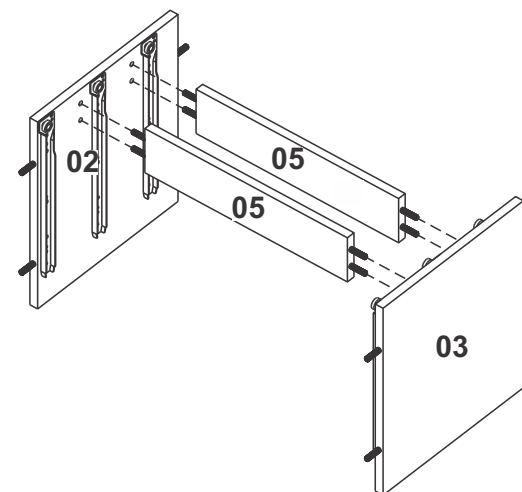

**2** Passo  
Step  
Paso

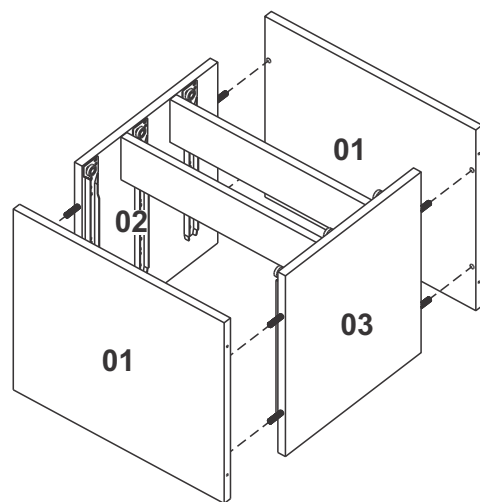

**3** Passo  
Step  
Paso

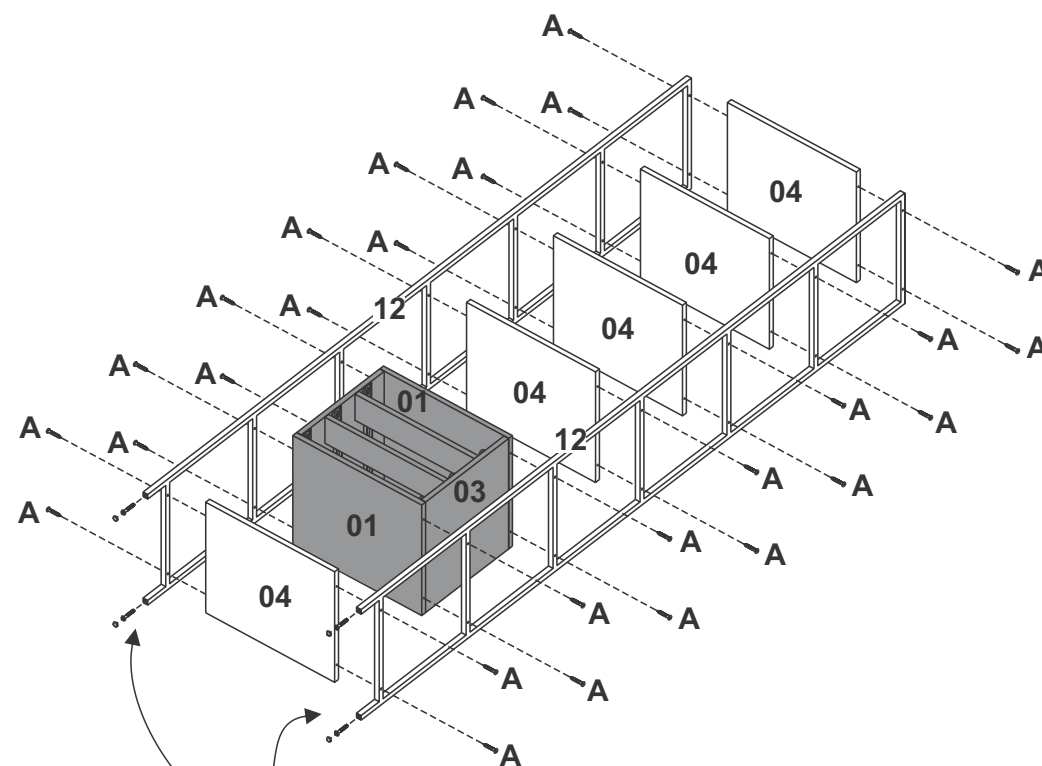

OPÇÕES DE POSICIONAMENTO DO MÓDULO DAS GAVETAS  
PLACEMENT OPTIONS OF THE DRAWERS MODULE  
OPCIONES DE COLOCACIÓN DEL MÓDULO DEL CAJONEROS

