

CAVAZOTTO

Rua Florianópolis, 570 - Centro - Coronel Freitas - SC - Brasil - CEP: 89840-000
Telefone: +55 (49) 3347-0207 - cavazotto@cavazotto.com.br

MANUAL DE MONTAGEM

CÔMODA 6 GAVETAS

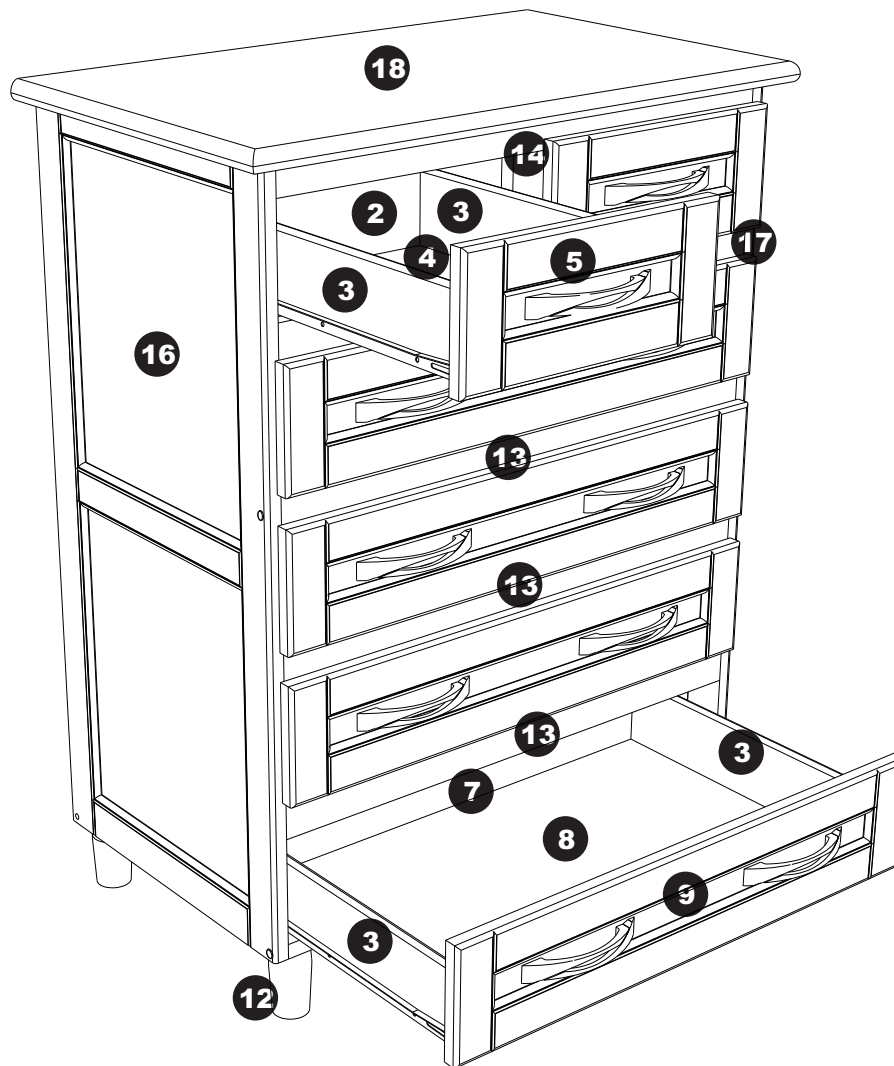

COMPONENTES

1 - Travessa frontal da gaveta menor (x2) (285x95x11mm)

2 - Travessa traseira da gaveta menor (x2) (285x95x11mm)

3 - Travessa lateral da gaveta (x12) (450x95x11mm)

4 - Fundo da gaveta menor (x2) (305x450x3mm)

5 - Frente da gaveta menor (x2) (350x155x20mm)

6 - Travessa frontal da gaveta maior (x4) (670x95x11mm)

7 - Travessa traseira da gaveta maior (x4) (670x95x11mm)

8 - Fundo da gaveta maior (x4) (690x450x3mm)

9 - Frente da gaveta maior (x4) (730x95x20mm)

14 - Travessa H frontal (pintada) (720x245x20mm)

15 - Travessa H traseira (720x245x20mm)

16 - Lateral esquerda (460x985x20mm)

17 - Lateral direita (460x985x20mm)

18 - Tampo (820x495x30mm)

19 - Fundo (x4) (980x190x3mm)

FERRAMENTAS NECESSÁRIAS

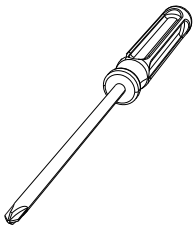

Chave philips

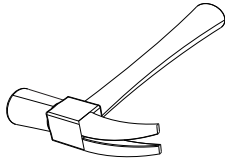

Martelo

ACESSÓRIOS

A

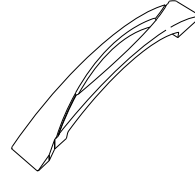

Puxador (x10)

B

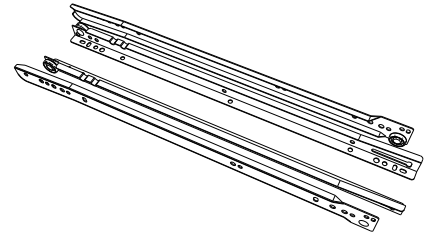

Par de corredeiras (x6)

C



Perfil 980mm para fundo (x3)

FERRAGENS

D

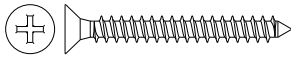

Parafuso philips 4x30mm (x24)

E

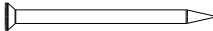

Prego 12x12 (x72)

F



Prego 8x8 (x236)

G



Parafuso philips 3,5x14mm (x48)

H

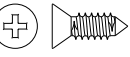

Parafuso philips 3,5x10mm (x2)

I

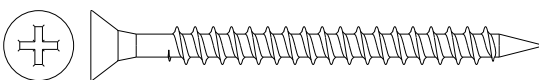

Parafuso philips 5,0x60mm (x4)

J

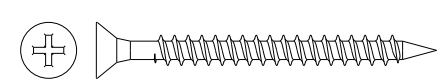

Parafuso philips 4,0x45mm (x10)

K



Tapa-furo 10mm (x6)

L

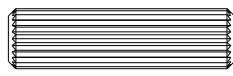

Cavilha 8x30 (x28)

M

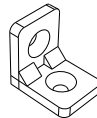

Cantoneira (x1)

01



Repita esse passo para montar a outra gaveta.

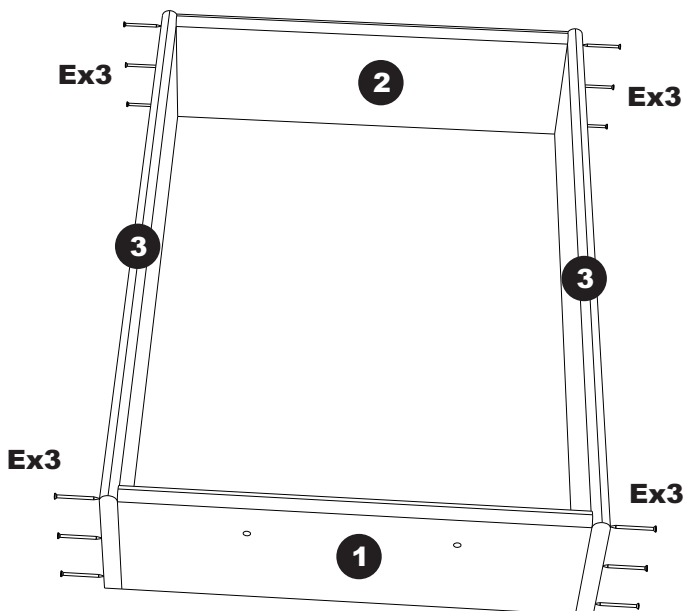

Junte as travessas laterais (3) com a travessa frontal da gaveta menor (1) e a travessa traseira da gaveta menor (2). Fixe-as utilizando pregos 12x12 (os maiores).

02



Repita esse passo para montar a outra gaveta.

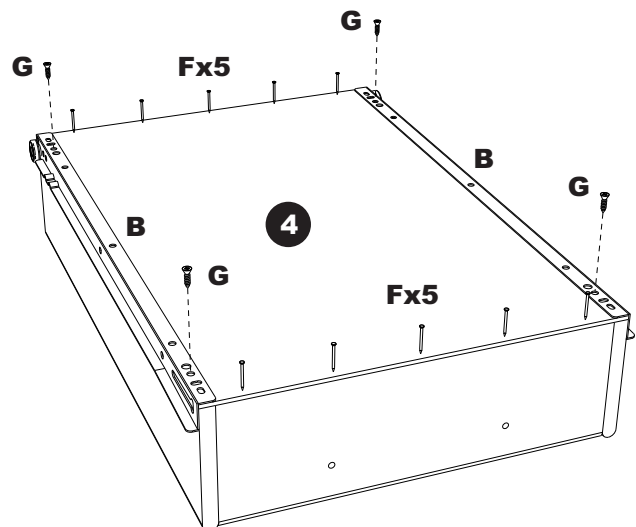

Aplique o fundo da gaveta menor (4) na estrutura montada anteriormente. Parafuse as corredeiras (B) nas laterais e fixe as pontas utilizando os pregos 8x8 (os menores).

03

!
Repita esse passo para montar a outra gaveta.

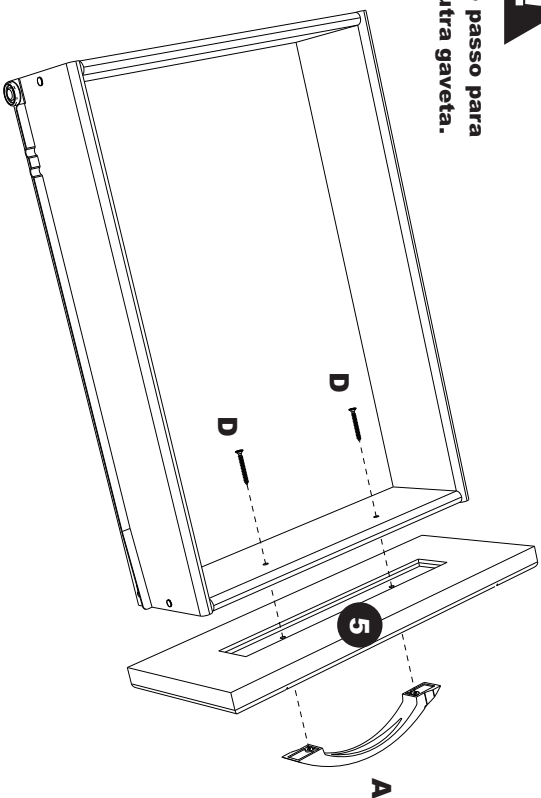

Fixe a frente da gaveta menor (5) junto com o seu puxador (A).

04

!
Repita esse passo para montar a outra gaveta.

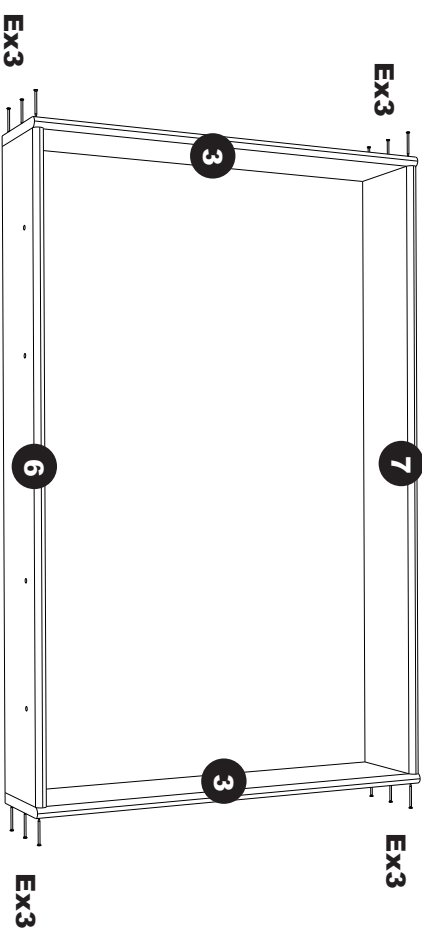

Junte as travessas laterais (3) com a travessa frontal da gaveta maior (6) e a travessa traseira da gaveta maior (7). Fixe-as utilizando pregos 12x12 (os maiores).

05

!
Repita esse passo para montar a outra gaveta.

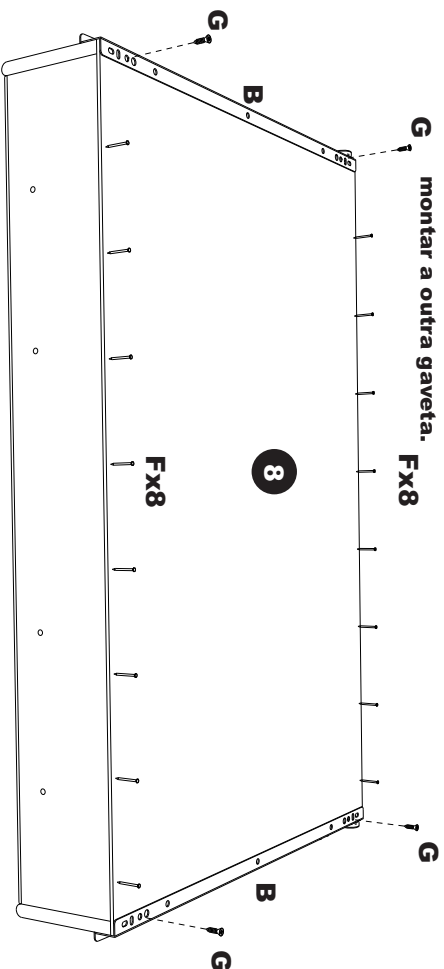

Alinhe o fundo da gaveta (8) na parte de baixo da estrutura montada anteriormente, e fixe as corredeiras (B) junto com o fundo (8). Depois, utilize os pregos 8x8 (G) para fixar as pontas do fundo (8).

06

!
Repita esse passo para montar a outra gaveta.

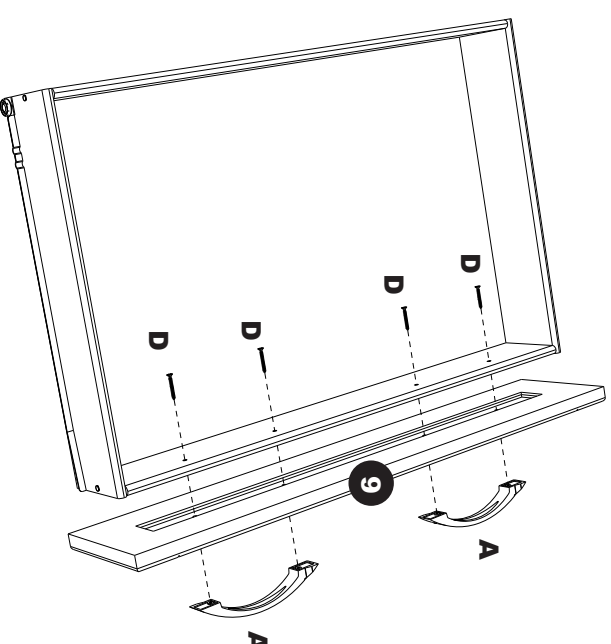

Fixe a frente da gaveta maior (9) junto com os seus puxadores (A).

07

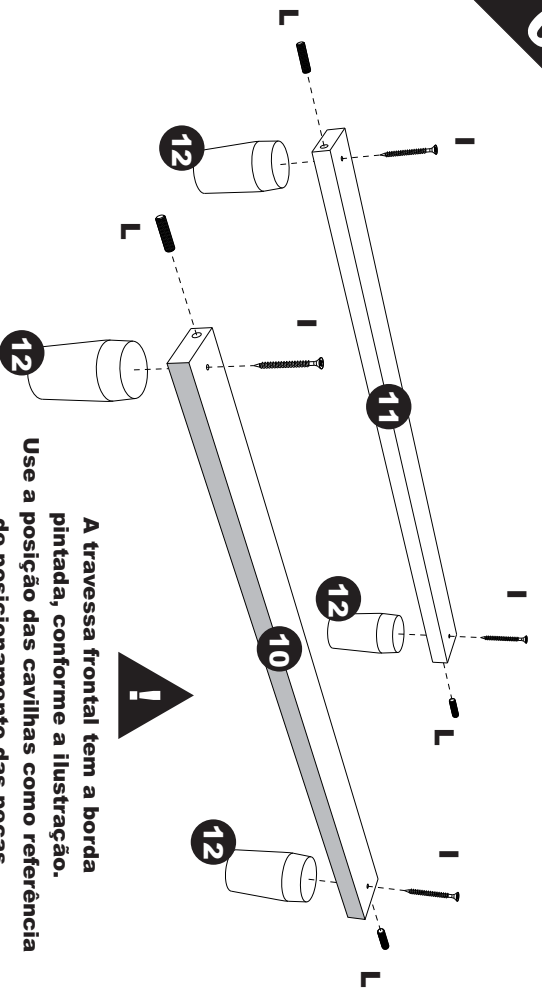

A travessa frontal tem a borda pintada, conforme a ilustração. Use a posição das cavilhas como referência de posicionamento das peças.

Fixe os pés (10) nas travessas inferiores (11 e 12), depois coloque as cavilhas (L) nos locais indicados.

08

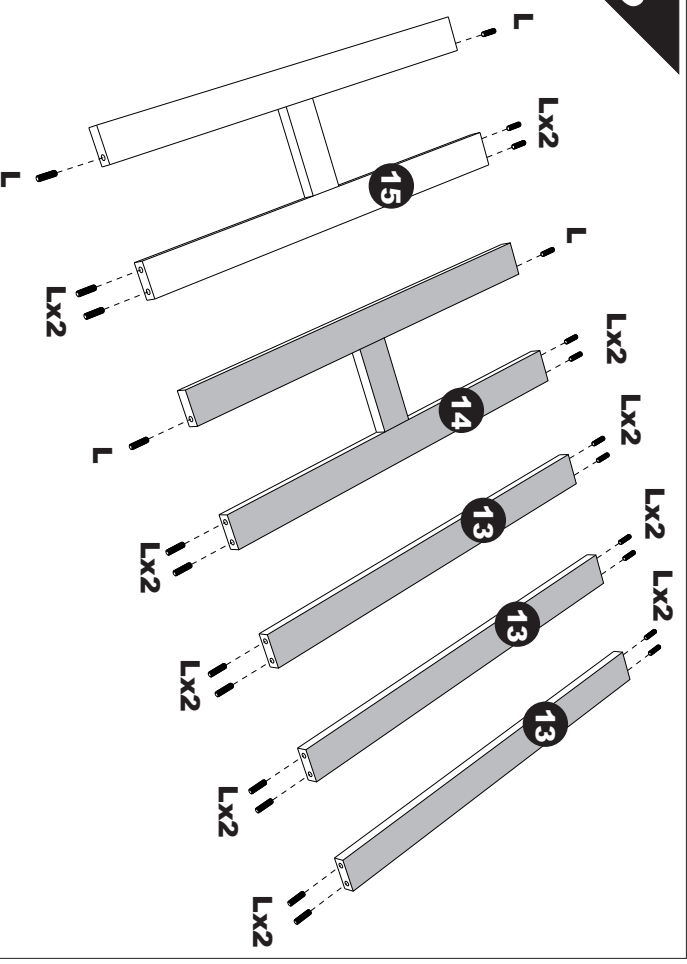

Injira as cavilhas (L) nas peças indicadas.

09

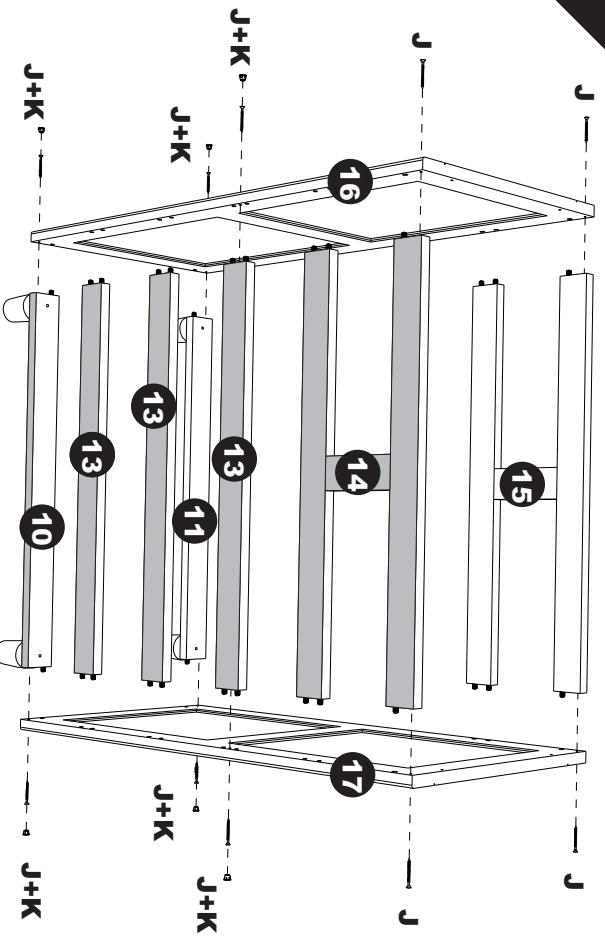

Junte as travessas inferiores (10 e 11) montadas com os pés (12) e as travessas cavilhadas anteriormente. Depois fixe-as nas laterais (16 e 17) de acordo com as posições indicadas.

10

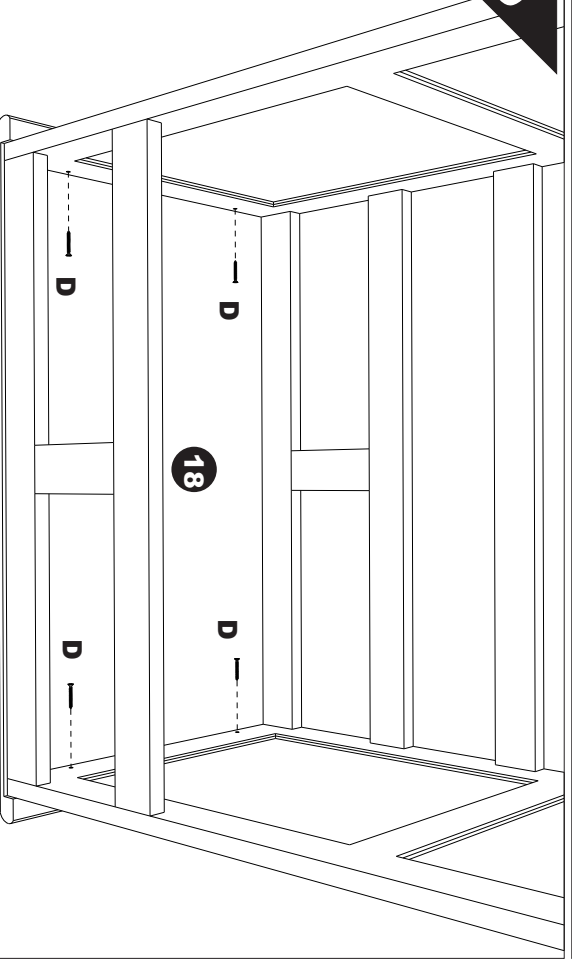

Fixe o tampo da cómoda (18) na estrutura montada anteriormente.

11

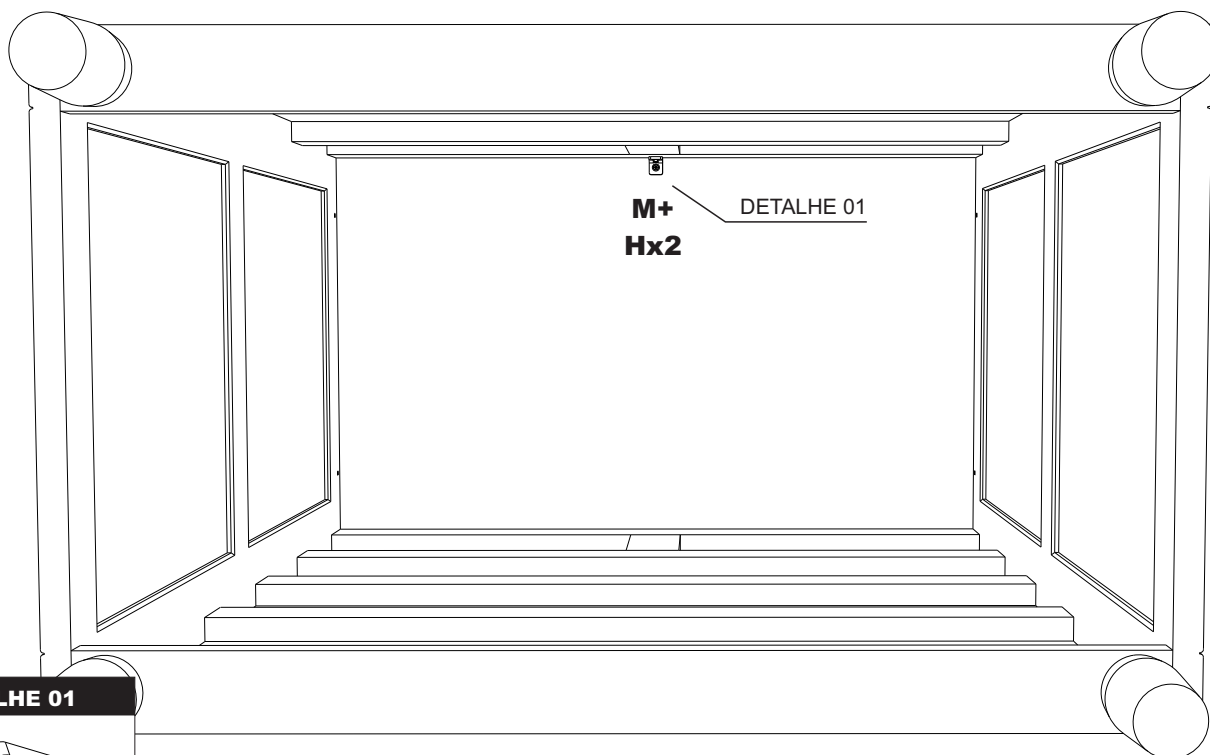

DETALHE 01

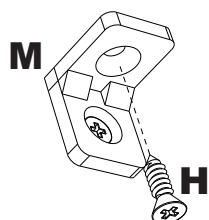

Fixe a cantoneira (M) no lugar indicado.

12



As laterais possuem
marcações onde devem
ser parafusadas as
corrediças.

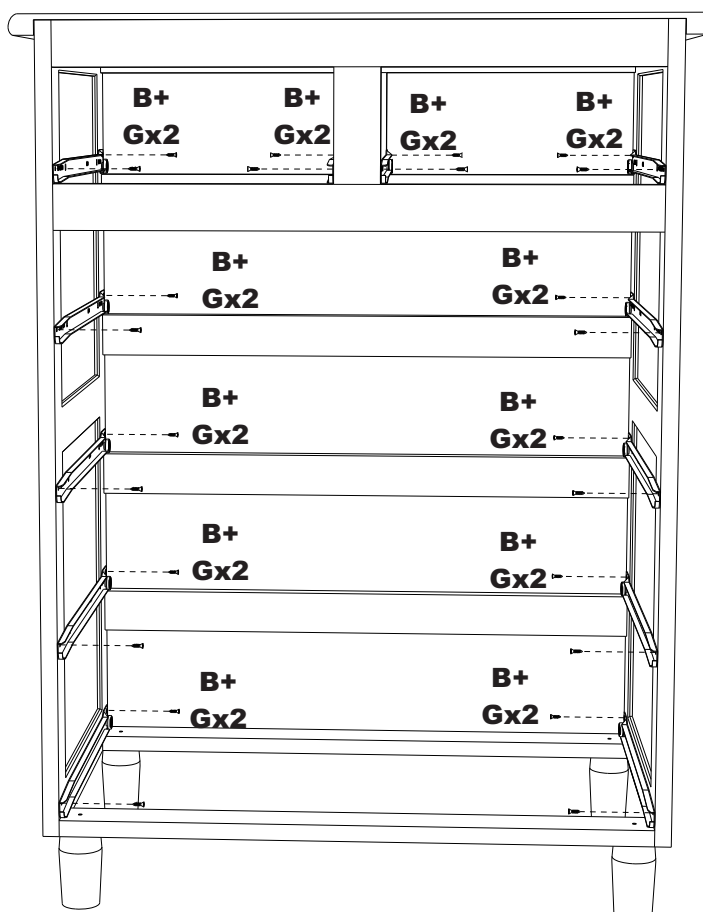

Fixe a outra parte das corrediças (B) nos locais indicados utilizando os parafusos 3,5x14 (G).

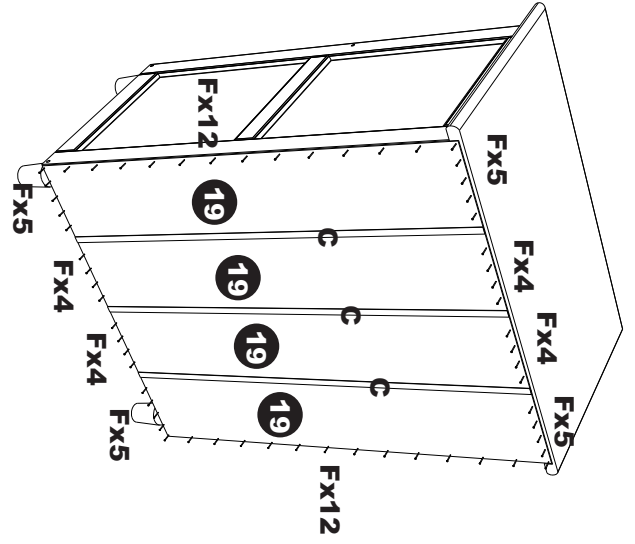
13

Fixe uma peça fundo da cômoda (19), insira o perfil (C), depois repita o processo até a última peça.

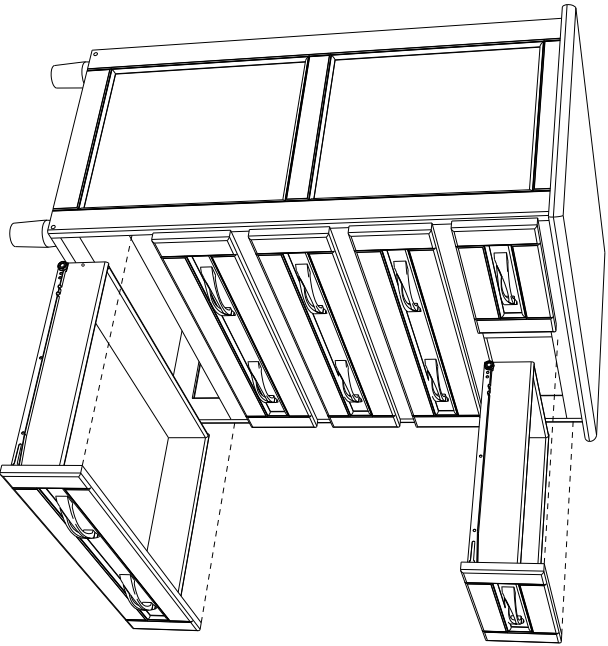
14

Insira as gavetas na cômoda.

MÓVEL CONCLUÍDO

