

CAVAZOTTO

Rua Florianópolis, 570 - Centro - Coronel Freitas - SC - Brasil - CEP: 89840-000
Telefone: +55 (49) 3347-0207 - cavazotto@cavazotto.com.br

MANUAL DE MONTAGEM

CÔMODA SAPATEIRA

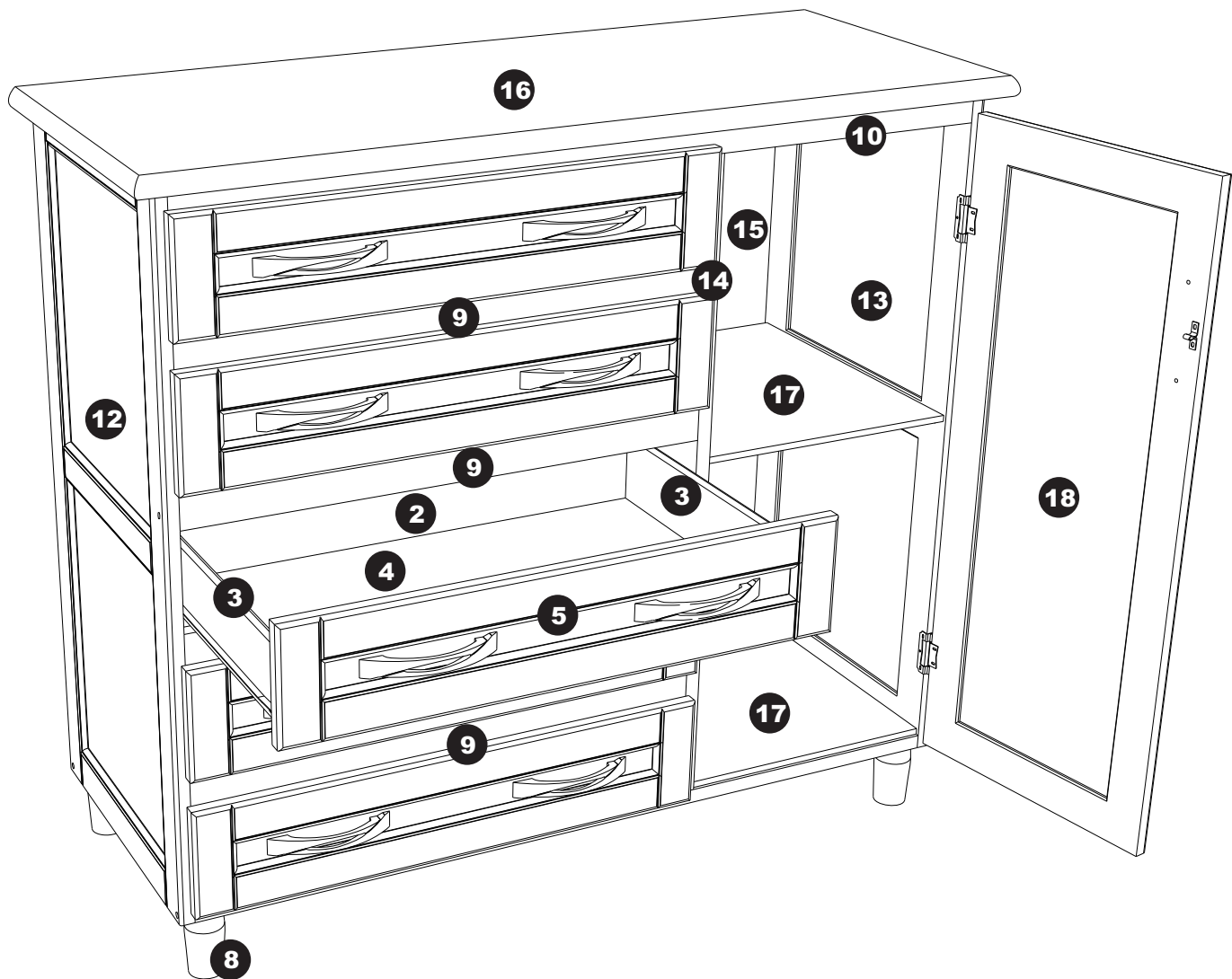

COMPONENTES

1 - Travessa frontal da gaveta (x5)
(670x95x11mm)

2 - Travessa traseira da gaveta (x5)
(670x95x11mm)

3 - Travessa lateral da gaveta (x10)
(450x95x11mm)

4 - Fundo da gaveta (x5)
(690x450x3mm)

5 - Frente da gaveta (x5)
(730x95x20mm)

6 - Travessa inferior frontal (borda
pintada) (1120x55x20mm)

7 - Travessa inferior traseira
(1120x55x20mm)

8 - Pés (50x50x90mm)

9 - Travessa frontal (720x55x20mm)

10 - Travessa superior frontal
(pintada) (1120x55x20mm)

11 - Travessa superior traseira
(1120x55x20mm)

12 - Lateral esquerda
(460x985x20mm)

13 - Lateral direita (460x985x20mm)

14 - Divisória (460x965x20mm)

15 - Fundo (x3) (385x980x3mm)

16 - Tampo (1220x495x30mm)

17 - Prateleira (x2) (380x445x9mm)

18 - Porta (390x935x20mm)

FERRAMENTAS NECESSÁRIAS

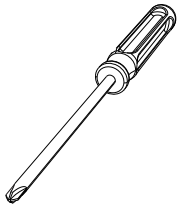

Chave philips

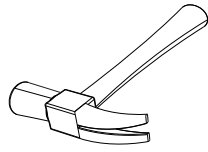

Martelo

ACESSÓRIOS

A



Puxador (x11)

B

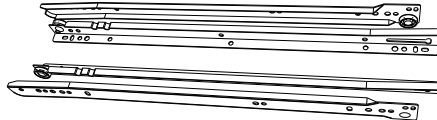

Par de corredeças (x5)

C

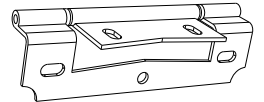

Dobradiça (x2)

D

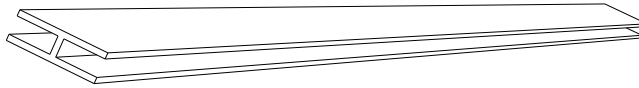

Perfil 980mm para fundo (x2)

E

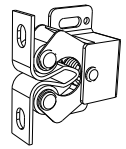

Fecho rolete (x1)

FERRAGENS

F

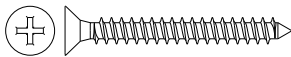

Parafuso philips 4x30mm (x24)

G

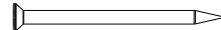

Prego 12x12 (x60)

H

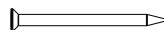

Prego 8x8 (x156)

I



Parafuso philips 3,5x14mm (x40)

J

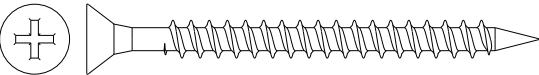

Parafuso philips 5,0x60mm (x4)

K

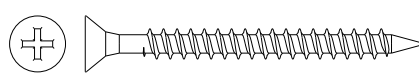

Parafuso philips 4,0x45mm (x14)

L



Tapa-furo 10mm (x6)

M



Cavilha 8x30 (x24)

N

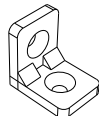

Cantoneira (x2)

O



Suporte para prateleira (x4)

P



Parafuso philips 3,5x16mm cabeça panela (x12)

Q

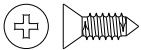

Parafuso philips 3,5x10mm (x4)

01

!
Repita esse passo para montar a outra gaveta.

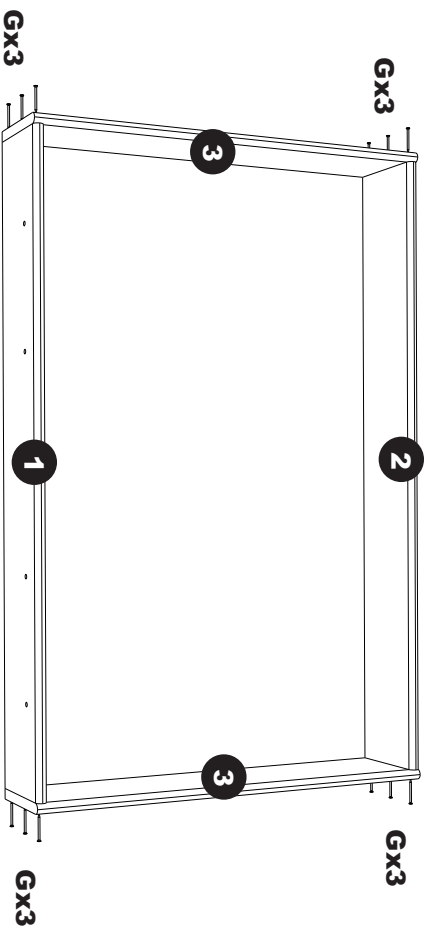

Junte as travessas laterais (3) com a travessa frontal da gaveta (1) e a travessa traseira da gaveta (2). Fixe-as utilizando pregos 12x12 (os maiores).

02

!
Repita esse passo para montar a outra gaveta.

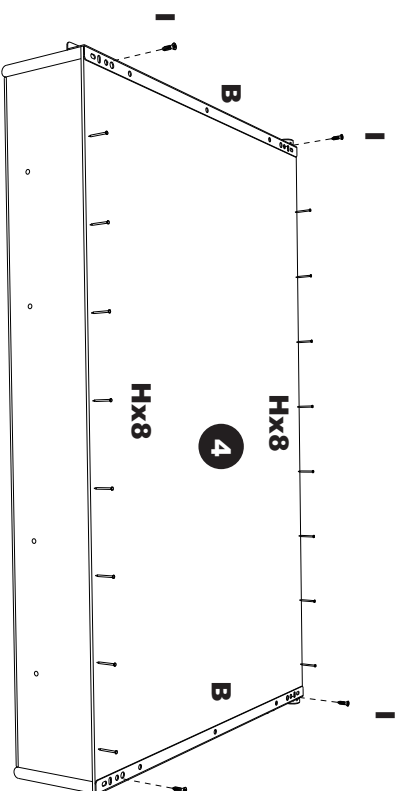

Alinhe o fundo da gaveta (4) na parte de baixo da estrutura montada anteriormente, e fixe as corredeiras (B) junto com o fundo (4). Depois, utilize os pregos 8x8 (H) para fixar as pontas do fundo (4).

03

!
Repita esse passo para montar a outra gaveta.

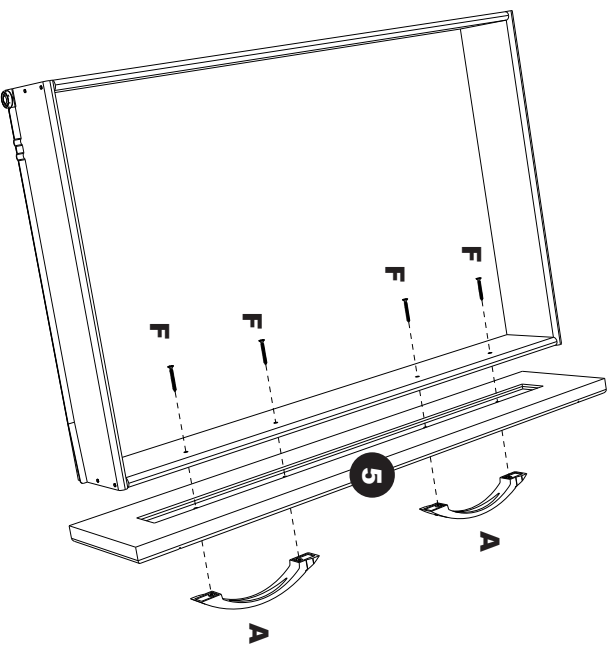

Fixe a frente da gaveta maior (5) junto com os seus puxadores (A).

04

!
A travessa frontal tem a borda pintada, conforme a ilustração. Use a posição das cavilhas como referência de posicionamento das peças.

Fixe os pés (8) nas travessas interiores (6 e 7), depois coloque as cavilhas (M) nos locais indicados.

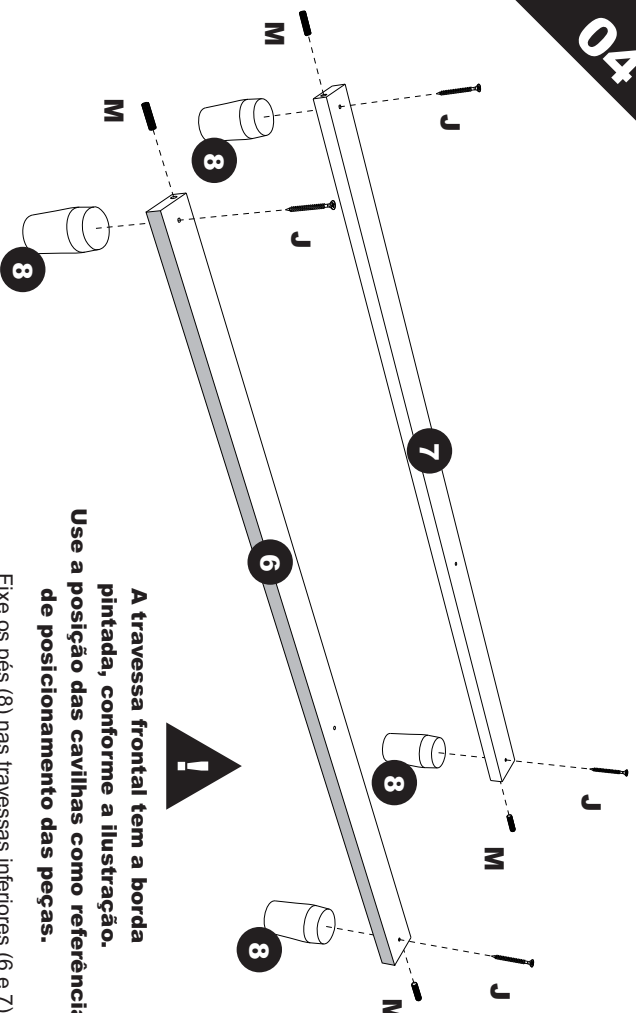

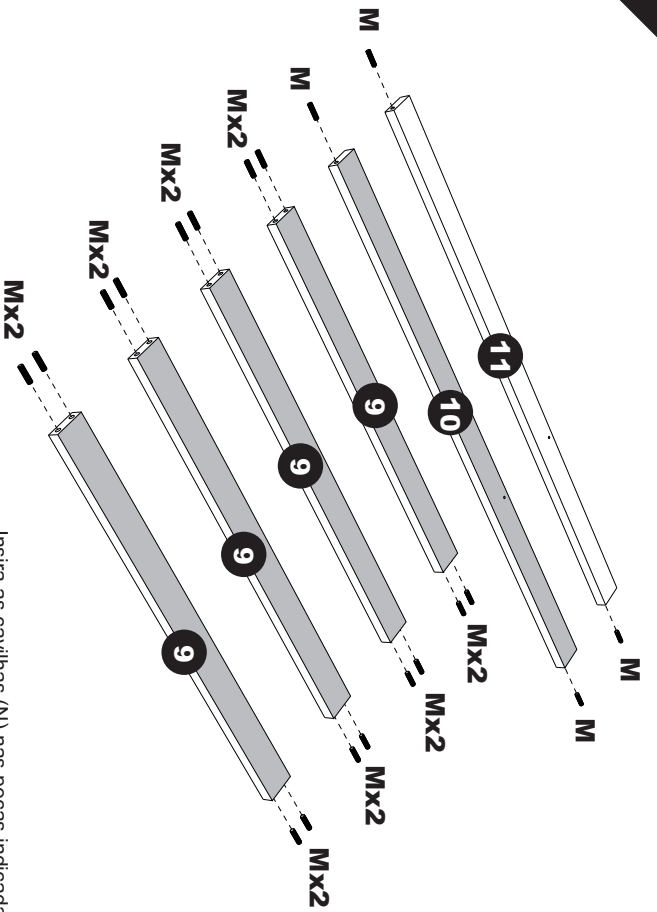
05

Insera as cavilhas (N) nas peças indicadas.

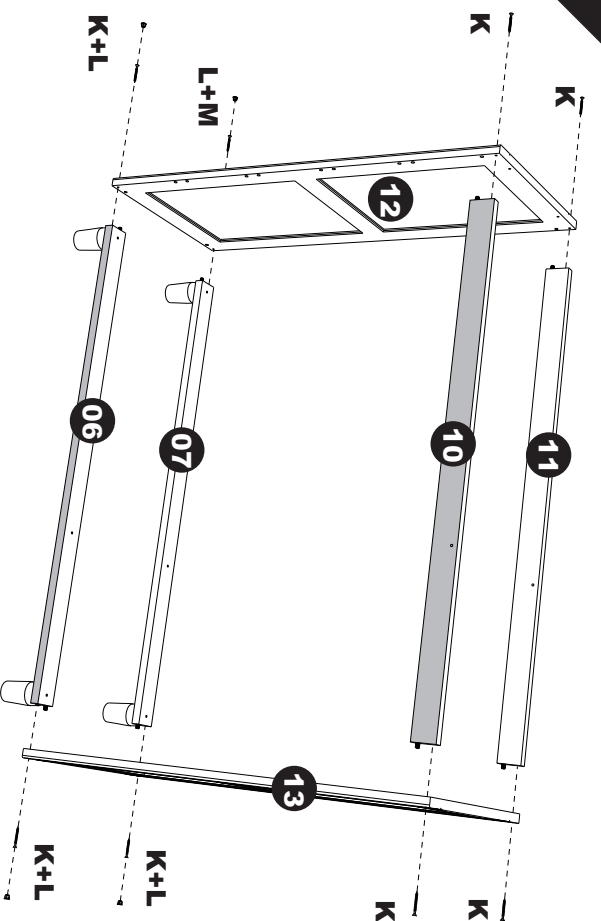
06

Posicione as travessas inferiores (6 e 7) e as travessas superiores (10 e 11), depois fixe-as nas laterais (12 e 13).

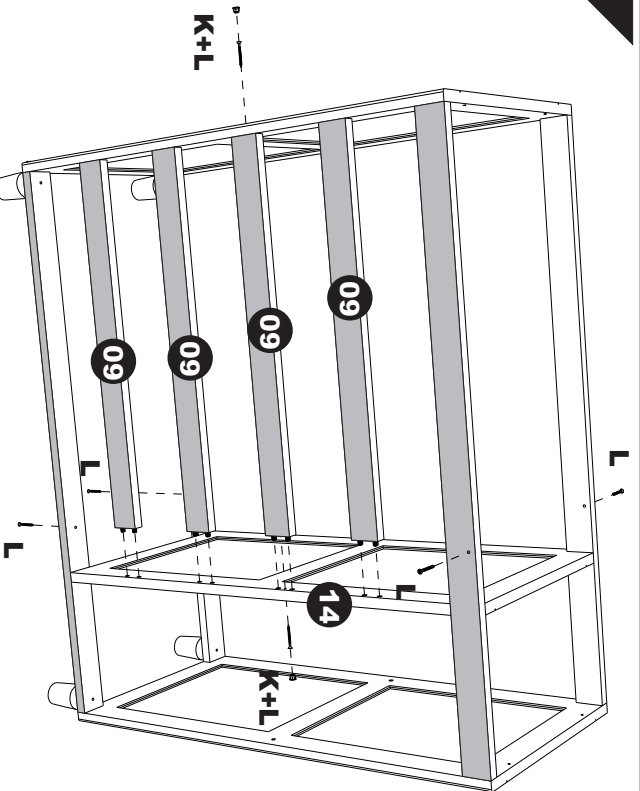
07

Encaixe as travessas cavilhadas anteriormente entre a lateral esquerda (12) e a divisória (14). Fixe a divisória na estrutura montada anteriormente.

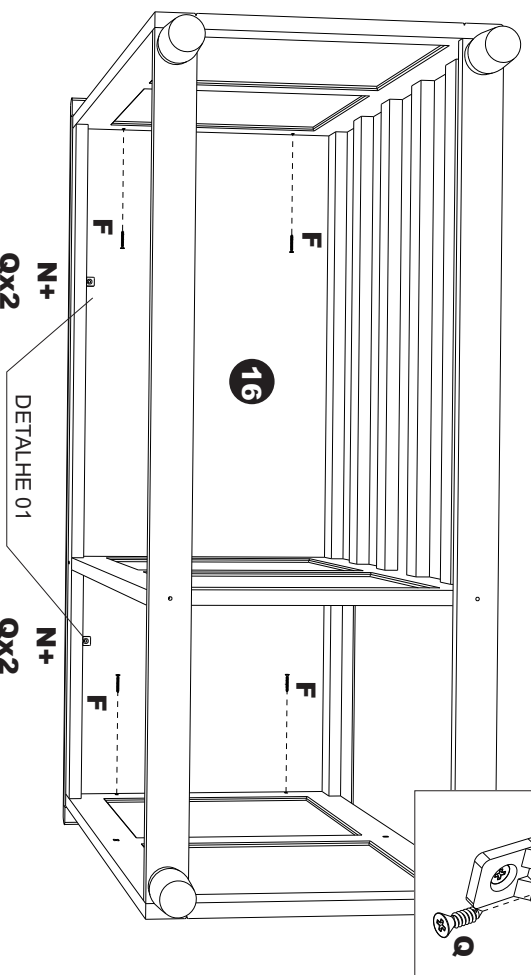
08

Encaixe o tampo (16) na estrutura e fixe-o. Depois fixe as cantoneiras (N) nos locais indicados na ilustração.



A lateral e a divisória possuem marcações onde devem ser parafusadas as corredeiras.

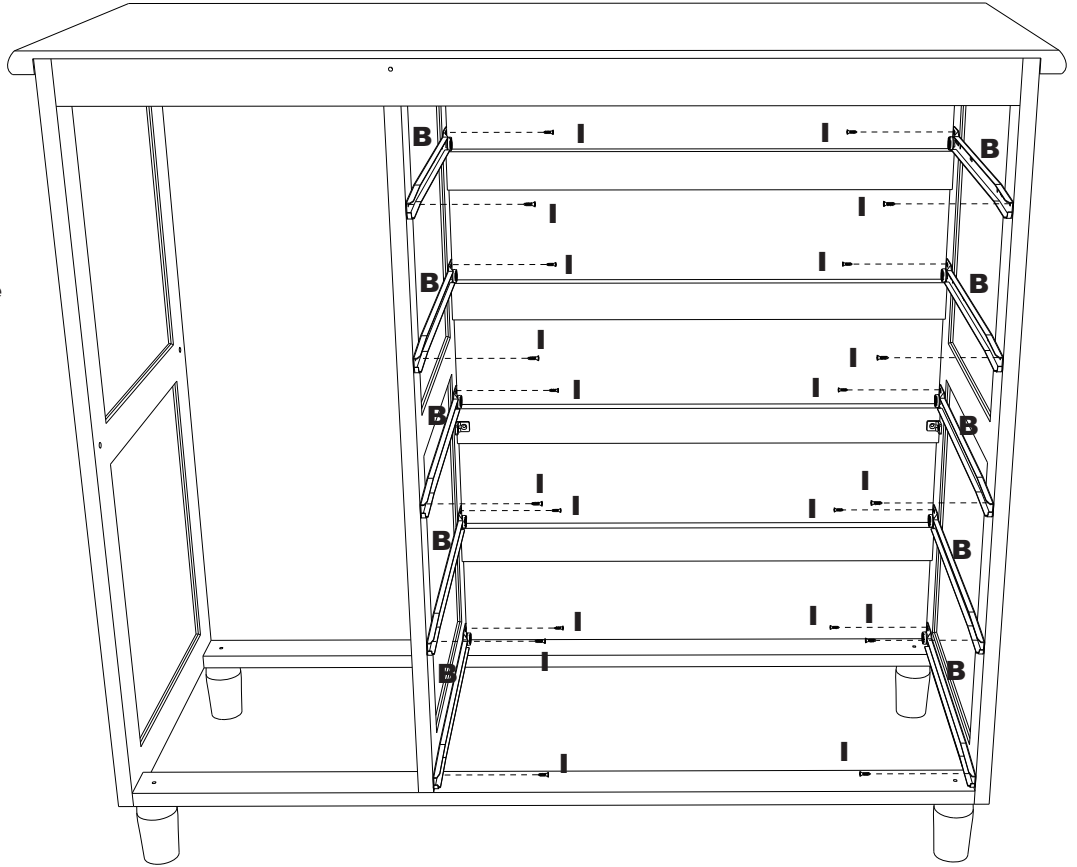

Fixe a outra parte das corredeiras (B) nos locais indicados utilizando os parafusos 3,5x14 (I).

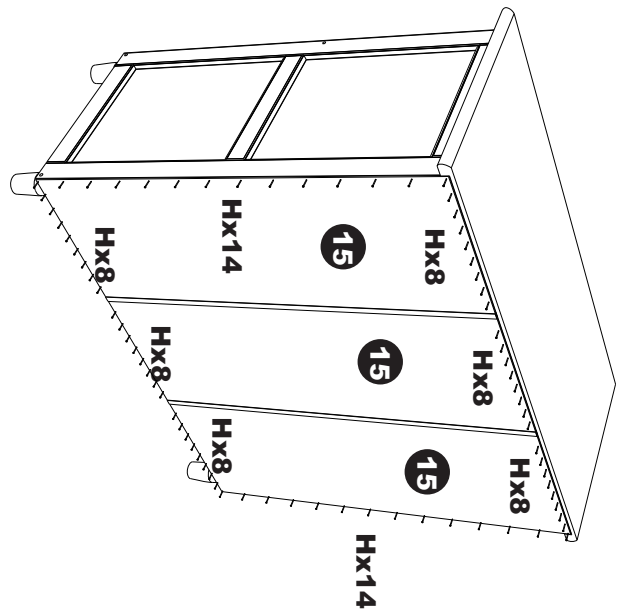

Fixe uma peça fundo da cômoda (15), insira o perfil (D), depois repita o processo até a última peça.



Utilize as marcações da porta para fixar as dobradiças.

Px2

C

Px2

C

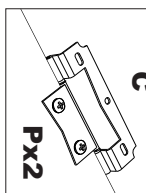

DETALHE 02

18

DETALHE 02



A parte menor da dobradiça deve ser fixada na porta.

Fixe a parte menor das dobradiças (C) na porta (18) com o auxílio das marcações.

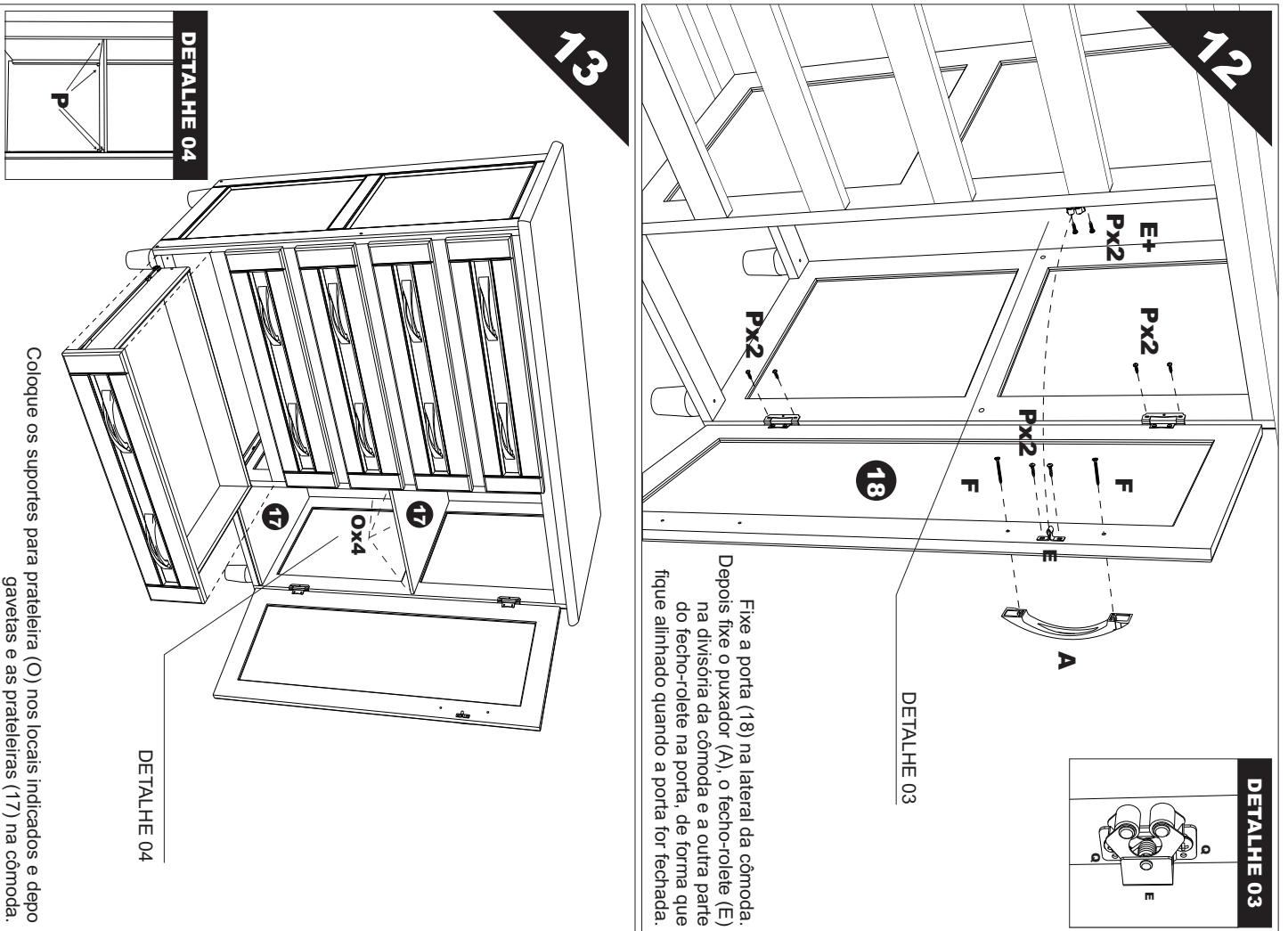

MÓVEL CONCLUÍDO

