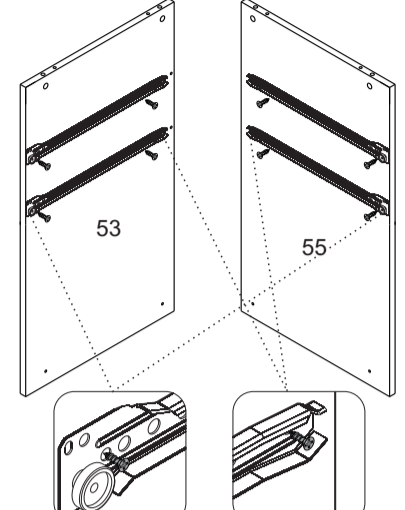
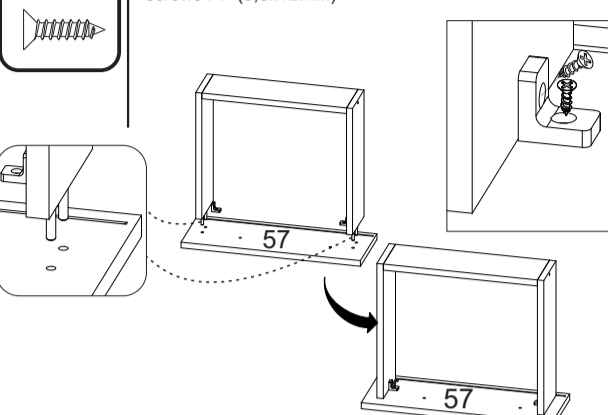
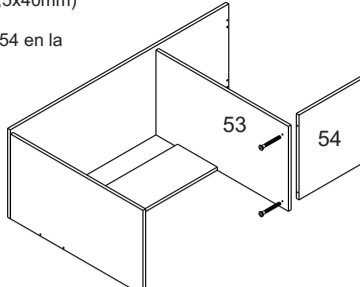
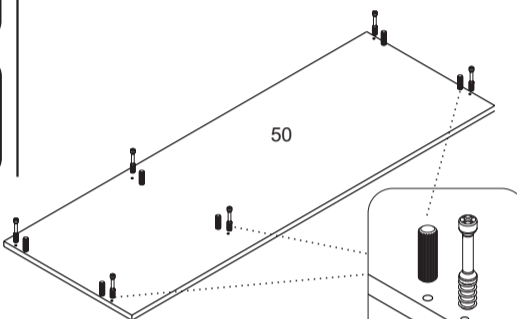
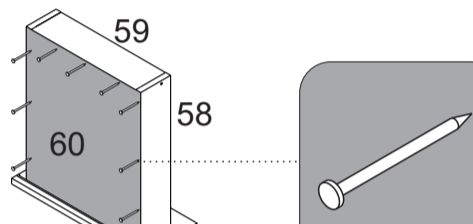
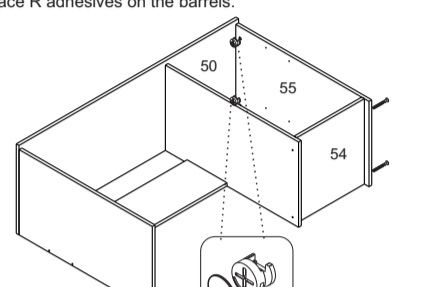
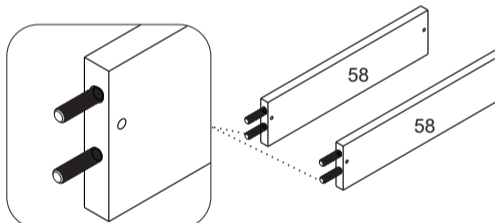
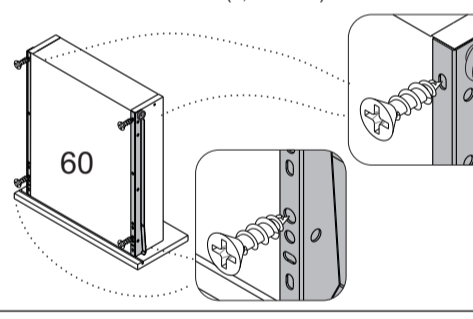
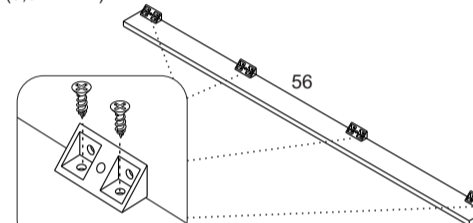
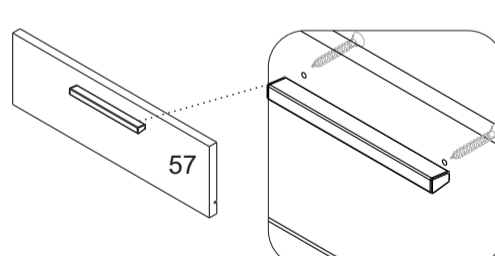
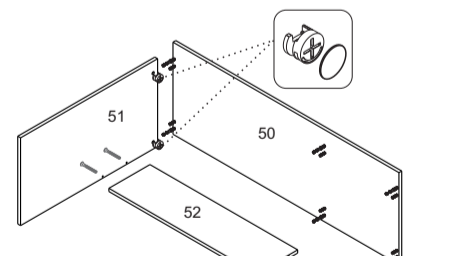
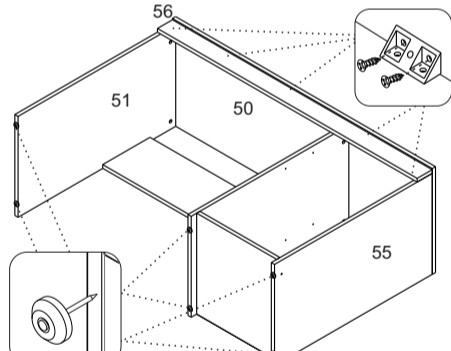
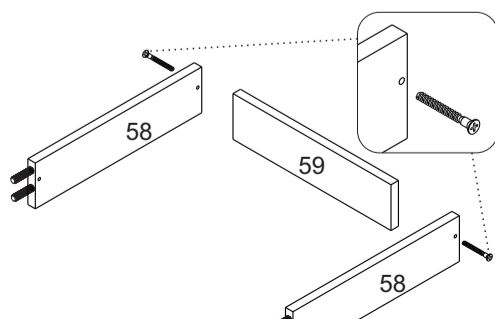
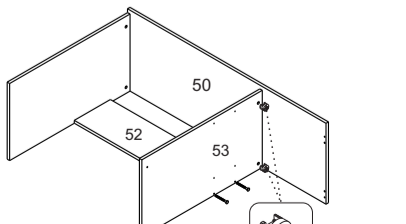
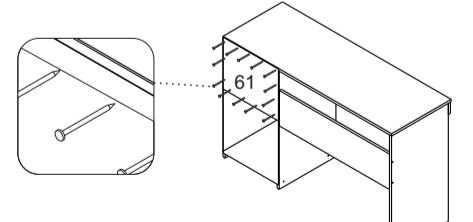
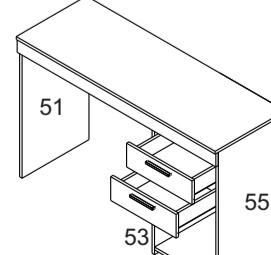

| | | |
|---|---|--|
| <p>PASSO 1 PASO 1 STEP 1</p> <p>1 - Posicione as corredeiras N nas marcações das peças 53 e 55 e fixe-as com os parafusos PP (3,5x12mm)</p> <p>1 - Coloque las corredeiras N en las marcas de las piezas 53 y 55, y fíjelas con los tornillos PP (3,5x12mm)</p> <p>1 - Align the N slides on the markings of part 53 and 55 fasten them with PP (3,5x12mm) screws</p>  <p>N 4</p> <p>PP 8</p> | <p>PASSO 6 PASO 6 STEP 6</p> <p>1 - Encaixe a peça 57 no conjunto montado no passo anterior 2 - Fixe as peças 58 na peça 57 utilizando as cantoneiras TA e os parafusos PP (3,5x12mm)</p> <p>1 - Encaje el conjunto ensamblado en el paso anterior en la pieza 57 2 - Fije las piezas 58 en la pieza 57 con las angulares TA e los tornillos PP (3,5x12mm)</p> <p>1 - Fit part 57 to the assembly assembled in the previous step 2 - Fix parts 58 to part 57 using the angle brackets TA and screws PP (3,5x12mm)</p>  <p>TA 4</p> <p>PP 4</p> | <p>PASSO 11 PASO 11 STEP 11</p> <p>1 - Fixe a peça 54 na peça 53 com os parafusos PH (3,5x40mm)</p> <p>1 - Fije la pieza 54 en la pieza 53 con los tornillos PH (3,5x40mm).</p> <p>1 - Fasten part 54 to part 53, then fasten them with (3,5x40mm) PH screws.</p>  <p>PH 2</p> |
| <p>PASSO 2 PASO 2 STEP 2</p> <p>1 - Encaixe os minifix B na peça 50 2 - Encaixe as cavilhas A (6x30mm) na peça 50</p> <p>1. Encaje los Minifix B en la pieza 50. 2. Encaje las clavijas A (6x30mm) en la pieza 50.</p> <p>1 - Fit the B minifix screws to part 50 2 - Insert (6x30mm) A dowels into part 50</p>  <p>B 6</p> <p>A 6</p> | <p>PASSO 7 PASO 7 STEP 7</p> <p>1 - Encaixe a peça 60 no canal da peça 57 e alinhe-as as peças 58 e 59. Em seguida fixe a peça 60 com os pregos D nas peças 57 e 58. Utilize 9 pregos por gaveta</p> <p>1. Encaje la pieza 60 en la ranura de la pieza 57 y las alinee a las piezas 58 y 59. A continuación, fije la pieza 60 con clavos D en las piezas 57 y 58. Use 9 clavos en cada cajón.</p> <p>1. Fit the part 60 to the groove of part 57 and align with it to the parts 58 y 59. Fit the part 60 with D nails on parts 57 y 58. Use 9 nails use 9 nails per drawer</p>  <p>D 18</p> | <p>PASSO 12 PASO 12 STEP 12</p> <p>1 - Encaixe a peça 55 na peça 50. Encaixe os tambores C na peça 55 e gire até travar 2 - Fixe a peça 55 na peça 54 com os parafusos PH (3,5x40mm) 3 - Cole os adesivos R sobre os tambores</p> <p>1 - Fasten part 55 to part 50. Insert C barrels to the side of part 55 and turn to lock with a Phillips screwdriver. 2 - Fasten part 55 to part 54 with PH (3,5x40mm) screws. 3 - Place R adhesives on the barrels.</p> <p>1 - Fasten part 55 to part 50. Insert C barrels to the side of part 55 and turn to lock with a Phillips screwdriver. 2 - Fasten part 55 to part 54 with PH (3,5x40mm) screws. 3 - Place R adhesives on the barrels.</p>  <p>C 2</p> <p>R 2</p> <p>PH 2</p> |
| <p>PASSO 3 PASO 3 STEP 3</p> <p>1 - Insira as cavilhas A (6x30mm) nas peças 58.</p> <p>1 - Introduzca las clavijas A (6x30mm) en las piezas 58.</p> <p>1 - Insert (6x30mm) A dowels into part 58</p>  <p>A 8</p> | <p>PASSO 8 PASO 8 STEP 8</p> <p>1 - Encoste a corredeira N na frente de gaveta e no fundo 60 e fixe-as com os parafusos PP (3,5x12mm)</p> <p>1. Apoye la corredeira N en el frontal de cajón y en el fondo 60, y fíjelas con los tornillos PP (3,5x12mm).</p> <p>1 - Place the N slide to the drawer face and to the bottom 60. Fasten them with PP (3,5x12mm) screws.</p>  <p>PP 8</p> <p>N 4</p> | <p>PASSO 13 PASO 13 STEP 13</p> <p>1 - Alinhe as cantoneiras T no topo da peça 56 e fixe-as com os parafusos PP (3,5x12mm)</p> <p>1 - Alinee los angulares T en el alto de la pieza 56 y fíjelas con los tornillos PP (3,5x12mm).</p> <p>1 - Align T angles on top of part 56 and fit with screws PP (3,5x12mm)</p>  <p>PP 8</p> <p>T 4</p> |
| <p>PASSO 4 PASO 4 STEP 4</p> <p>1 - Alinhe os puxadores S nos furos das frentes de gaveta e fixe-os com os parafusos W (3,5x25mm)</p> <p>1. Alinee las manijas S en los agujeros de los frontales de cajón y fíjelas con los tornillos W (3,5x25mm).</p> <p>1 - Align the S handles on the drawer front and fasten them with (3,5x25mm) W screws</p>  <p>S 2</p> <p>W 4</p> | <p>PASSO 9 PASO 9 STEP 9</p> <p>1 - Encaixe a peça 51 na peça 50. Encaixe os tambores C na peça 51 e gire até travar 2 - Fixe a peça 52 na peça 51 com os parafusos PH (3,5x40mm) 3 - Cole os adesivos R sobre os tambores</p> <p>1. Encaje la pieza 51 en la pieza 50. Encaje los barriles C en la pieza 51 y gire hasta trabar. 2. Fije la pieza 52 en la pieza 51 con los tornillos PH (3,5x40mm). 3. Pegue los adhesivos R sobre los barriles.</p> <p>1 - Fit the part 51 in part 50. Insert C barrels to the side of part 51 and turn to lock with a Phillips screwdriver. 2 - Fit the part 52 in part 51 with screws (3,5x40mm) PH 3 - Place R adhesives on the barrels</p>  <p>C 2</p> <p>R 2</p> <p>PH 2</p> | <p>PASSO 14 PASO 14 STEP 14</p> <p>1 - Alinhe a peça 56 entre as peças 51 e 55 e encoste-a no tampo 50. Em seguida utilize os parafusos PP (3,5x12mm) para fixar as cantoneiras da peça 56 na peça 50. 2 - Fixe as sapatas L na base das peças 51, 53 e 55</p> <p>1 - Alinee la pieza 56 entre las piezas 51 y 55, y la apoye a la cubierta 50. A continuación, use los tornillos PP (3,5x12mm) para fijar los angulares de la pieza 56 en la pieza 50. 2 - Fije las zapatas L en la base de las piezas 51, 53 y 55.</p> <p>1 - Align part 56 between part 51 and 55 and touch it to top 50. Then use the Screws PP (3,5x12mm) to secure the angle T of part 56 to part 50. 2 - Fasten the L shoes to the parts 51, 53 and 55.</p>  <p>PP 8</p> <p>L 6</p> |
| <p>PASSO 5 PASO 5 STEP 5</p> <p>1 - Alinhe a peça 59 entre as peças 58 e fixe-as com os parafusos Y (3,5x40mm)</p> <p>1. Alinee la pieza 59 entre las piezas 58 y fíjelas con los tornillos Y (3,5x40mm).</p> <p>1 - Align part 59 between parts 58 and secure with screws Y (3,5x40mm)</p>  <p>PH 2</p> | <p>PASSO 10 PASO 10 STEP 10</p> <p>1 - Encaixe a peça 53 na peça 50. Encaixe os tambores C na peça 53 e gire até travar 2 - Fixe a peça 53 na peça 52 com os parafusos PH (3,5x40mm) 3 - Cole os adesivos R sobre os tambores</p> <p>1. Encaje la pieza 53 en la pieza 50. Encaje los barriles C en la pieza 53 y gire hasta trabar. 2. Fije la pieza 53 en la pieza 52 con los tornillos PH (3,5x40mm). 3. Peque los adhesivos R sobre los barriles.</p> <p>1 - Fit the part 53 in part 50. Insert C barrels to the side of part 53 and turn to lock with a Phillips screwdriver. 2 - Fit the part 53 in part 52 with PH (3,5x40mm) screws. 3 - Place R adhesives on the barrels.</p>  <p>C 2</p> <p>R 2</p> <p>PH 2</p> | <p>PASSO 15 PASO 15 STEP 15</p> <p>1 - ATENÇÃO: Antes de fixar o fundo, verifique o esquadro da mesa e fixe-o com a face pintada para fora do móvel. 2 - Alinhe a peça 61 entre a lateral e a divisão e entre o tampo e a base da mesa. Em seguida fixe-a com os pregos D</p> <p>1. PRECAUCIÓN: antes de fijar los fondos compruebe la escuadra del armario. Ponga la parte pintada para fuera del producto. 2. Alinee una pieza 61 entre la lateral y a la división y entre la cubierta y la base de la mesa. Fíjela con los clavos D.</p> <p>1 - ATTENTION: Before fixing the bottom, check the table square and fix it with the painted face out of the furniture 2 - Align piece 61 between the side and the room and between the table top and base. Then fix it with the nails D</p>  <p>D 16</p> |
| | | <p>PASSO 16 PASO 16 STEP 16</p> <p>1 - Encaixe as gavetas na mesa através das corredeiras.</p> <p>1 - Encaje los cajones en la mesa a través de las corredeiras.</p> <p>1 - Fit the drawers through the slides.</p>  <p>PH 2</p> |