

CAPACIDADE DE CARGA E DIMENSÃO TOTAL

Capacidad de carga y dimensión total
Load capacity and total dimension

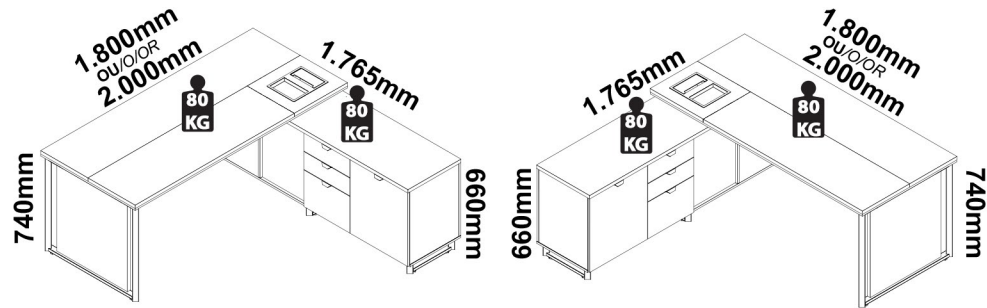

MANUTENÇÃO E LIMPEZA

- Pano levemente umedecido com água, seguido de pano seco.
- Nunca utilizar produtos químicos ou abrasivos.
- **Mantenimiento y Limpieza:** Paño ligeramente humedecido con agua, seguido de un paño seco.
- No utilice nunca productos químicos o abrasivos.
- **Maintenance and Cleaning:** Cloth slightly moistened with water, followed by cloth seo.
- Never use chemicals or abrasives.

RECOMENDAÇÕES

- Siga atentamente todas as instruções de montagem;
- Monte seu produto no local ou próximo de onde será colocado. Movimentações do produto já montado podem avariá-lo;
- Faça a montagem em uma superfície limpa e plana. Aconselhamos usar a própria embalagem de papelão e plástico para forrar o chão;
- Verifique se as quantidades de peças e acessórios estão de acordo com o Manual;
- Compare atentamente os furos de cada peça com a ilustração do manual
- Se o produto necessitar fixação na parede, tenha cuidado para não atingir fios e canos ao furar a parede;
- É responsabilidade do montador seguir as instruções do Manual de Montagem que são fundamentais para a estruturação do produto.

Recommendations

- Carefully follow all assembly instructions;
- Assemble your product at or near where it will be placed. Movements of the product already assembled may damage it;
- Mount on a clean, flat surface. We advise you to use the cardboard and plastic packaging itself to cover the floor;
- Check that the quantities of parts and accessories are in accordance with the manual;
- Carefully compare the holes in each part with the illustration in the manual;
- If the product needs to be fixed to the wall, be careful not to reach wires and pipes when drilling into the wall;
- It is the assembler's responsibility to follow the instructions in the Assembly Manual, which are fundamental for structuring the product.

Recomendaciones

- Siga cuidadosamente todas las instrucciones de montaje;
- Ensamble su producto en o cerca de donde se colocará. Los movimientos del producto ya ensamblado pueden dañarlo;
- Montar sobre una superficie limpia y plana. Le recomendamos que utilice el embalaje de cartón y plástico para cubrir el piso;
- Compruebe que las cantidades de piezas y accesorios están de acuerdo con el manual;
- Compare cuidadosamente los agujeros en cada parte con la ilustración en el manual;
- Si el producto necesita ser fijado a la pared, tenga cuidado de no alcanzar cables y tuberías al perforar la pared;
- Es responsabilidad del ensamblador seguir las instrucciones del Manual de ensamblaje, que son fundamentales para estructurar el producto.

INSTRUÇÕES DE MONTAGEM ASSEMBLY INSTRUCTIONS INSTRUCCIONES DE MONTAJE

MESA DIRETOR DIRECTOR'S DESK MESA DIRECTIVA

DIREITA: BOS1817-BOS2017

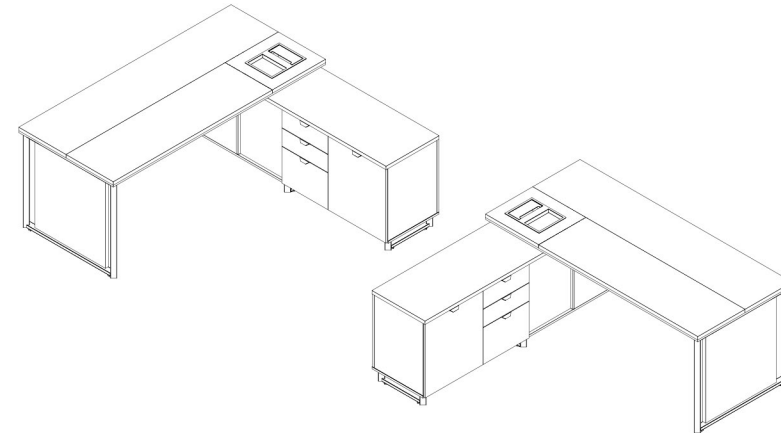

ESQUERDA: BOS1818-BOS2018

REF. #BOS1817-1818-2017-2018

São necessários:
Son necesarios:
Are necessary:



*Parafusadeira
Atomillador
Screwdriver



*Martelo
Martillo
Hammer



Chave Cruzada
Llave cruzada
Cross wrench



**Trena
Cinta métrica
Measuring tape



20min



2 Pessoa
Persona
Person

**Facilita a montagem / Facilita un montaje / Facilitates mounting.
**Para identificar as peças / Para identificar las partes / To identify the parts.

REV.: 00 - 19/04/2025



Office

MÓVEIS CORPORATIVOS

DIREITA: BOS1817-BOS2017

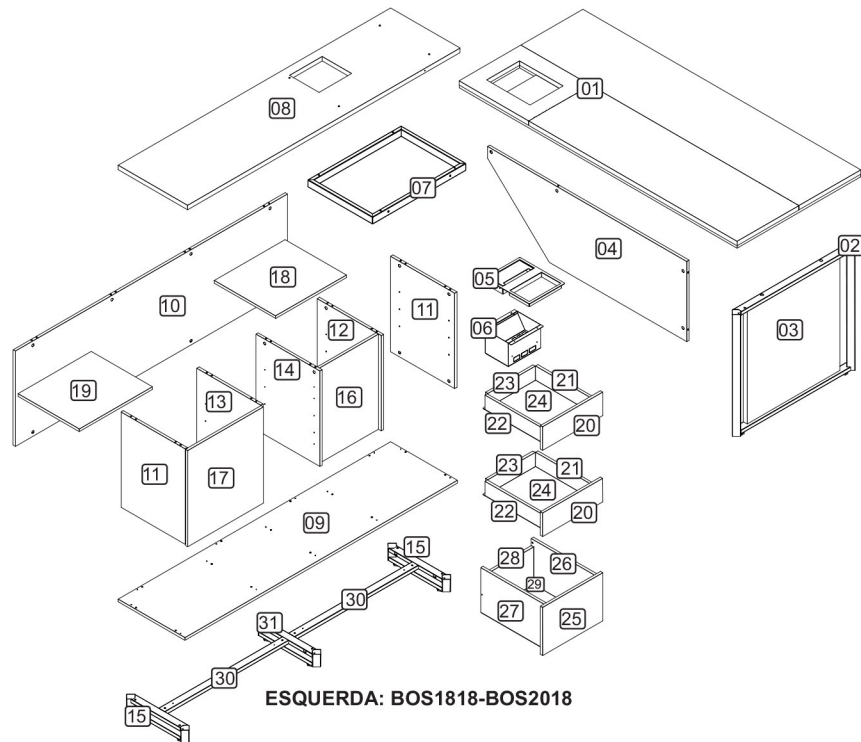
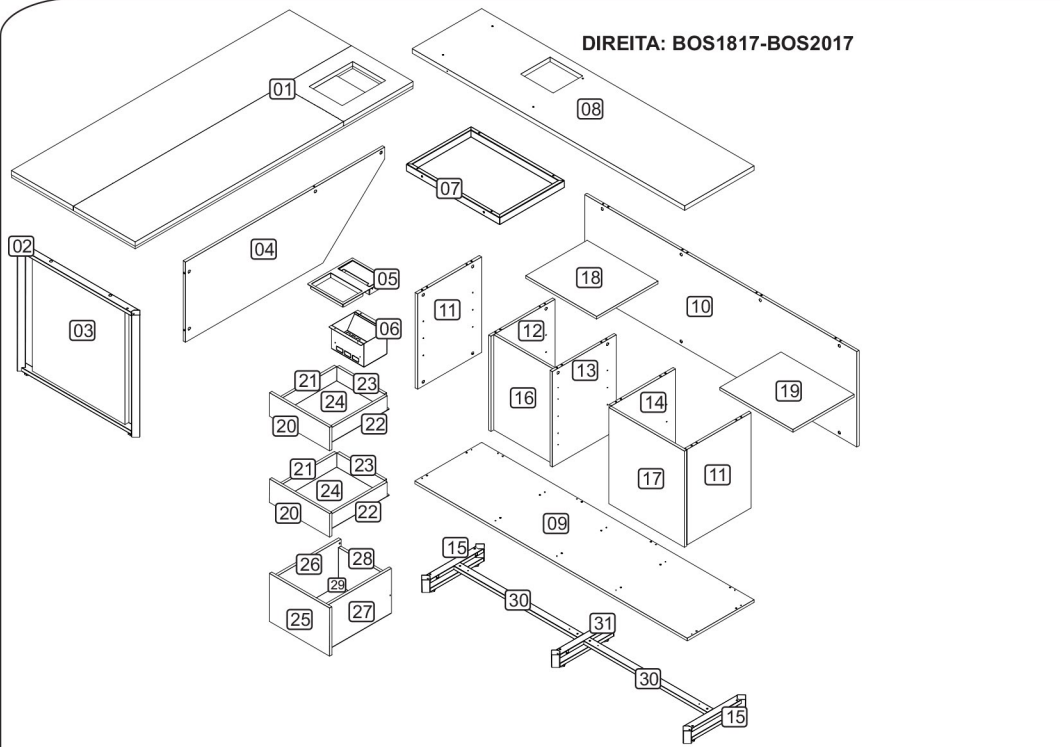

ESQUERDA: BOS1818-BOS2018

LISTA DE PEÇAS

EXAMINE COMPLETAMENTE TODAS AS PEÇAS ANTES DE INICIAR O TRABALHO.

Lista de piezas: Examine completamente todas las piezas antes de comenzar a trabajar.
List of pieces: Completely examine all parts before starting work.

NÚMERO NUMBER NÚMERO	DESCRIÇÃO DESCRIPTION DESCRIPCIÓN	QUANTIDADE QUANTITY CANTIDAD	DIMENSÕES DIMENSIONS DIMENSIONES	NÚMERO NUMBER NÚMERO	DESCRIÇÃO DESCRIPTION DESCRIPCIÓN	QUANTIDADE QUANTITY CANTIDAD	DIMENSÕES DIMENSIONS DIMENSIONES
01	Tampo	01	1800x800x40 2000x800x40	16	Tampa Saque	01	1800x800x40 2000x800x40
02	Pedestal	01	795x685X55	17	Porta	01	795x685X55
03	Aplique	01	644x600x25	18	Prateleira Maior	01	644x600x25
04	Painel Frontal	01	644x600x54	19	Prateleira Menor	01	644x600x54
05	Colarinho	01	1682x450x15	20	Frente de gaveta	01	1682x450x15
06	Suporte Tomadas	01	208x148x0,75	21	Lateral Gaveta Esq	02	208x148x0,75
07	Distanciador	01	209x188x132	22	Lateral Gaveta Dir	02	209x188x132
08	Tampo armário	01	292x231x42	23	Costa Gaveta	02	292x231x42
09	Base	01	209x188x132	24	Fundo Gaveta	02	209x188x132
10	Costa	01	292x231x42	25	Frente Pasta	01	292x231x42
11	Lateral	02	1682x450x15	26	Lateral Gavetão Esq.	01	1682x450x15
12	Divisão Nicho	01	208x148x0,75	27	Lateral Gavetão Dir.	01	208x148x0,75
13	Divisão Esquerda	01	209x188x132	28	Costa Gavetão	01	209x188x132
14	Divisão Direita	01	292x231x42	29	Fundo Gavetão	01	292x231x42
15	Rodapé Dir. Esq.	02	209x188x132	30	Longarina	02	209x188x132
				31	Rodapé Central	01	209x188x132

Em milímetros / En milímetros / In millimetres.

Em milímetros / En milímetros / In millimetres.

LISTA DE ACESSÓRIOS







A SEPARAÇÃO DOS ACESSÓRIOS ANTES DE INICIAR O TRABALHO FACILITARÁ O MESMO.
OS PARAFUSOS E CAVILHAS ESTÃO NA ESCALA REAL. EM CASO DE DÚVIDA COLOQUE O





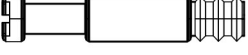
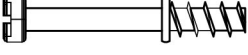



ACESSÓRIO SOBRE A IMAGEM.



Lista de accesorios: La separación de los accesorios antes de comenzar el armado facilitará el mismo. Los tornillos y taquetes son en escala real. En caso de dudas sobre la identificación, coloque el accesorio en la imagen.

List of accessories: The separation of the accessories before you start the assembly will facilitate the same.

The screws and dowels are in real scale. In case of doubts about the identification, place the accessory on the image.

CÓD. CÓD. COD.	IMAGEM IMAGEN IMAGE	DESCRIÇÃO DESCRIPCIÓN DESCRIPTION	QTD. CTD. QTD.
A2		PARAFUSO CABEÇA CHATA 3,5x14mm Tornillo de cabeza plana Flat head screw	36
A3		PARAFUSO CABEÇA PANELA 3,5x20mm Tornillo de cabeza troncoconica Pan head screw	24
A8		PARAFUSO CABEÇA PANELA 4,0x14mm Tornillo de cabeza troncoconica Pan head screw	28
A29		PARAFUSO MINIFIX M6x33mm Tornillo minifix Superb thread	4
A32		PARAFUSO MINIFIX ROSCA SOBERBA Tornillo minifix rosca soberbia Superb thread minifix screw	32
A35		TAMBOR MINIFIX Tambor minifix Cam lock	36
A36		BUCHA M6X13mm Cojinete Bushing	9
A44		PARAFUSO CABEÇA PANELA M6x16mm Tornillo de cabeza troncoconica Pan head screw	8
B2		SUPOORTE PRATELEIRA 5x20mm Soporte de estante Shelf Support	12

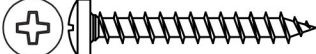
CÓD. CÓD. COD.	IMAGEM IMAGEN IMAGE	DESCRIÇÃO DESCRIPCIÓN DESCRIPTION	QTD. CTD. QTD.
C7		PUXADOR Arrancador Puller	4
D1		CAVILHA 8x30mm Taquete Wooden Dowel	40
F1		TAPA FURO ADESIVO Tapón adhesivo Bore patch adhesive	34
G7		DOBRADIÇA CANECO C/ PISTÃO RETA BAIXA Bisagra Hinge	2
H6		CANTONEIRA PARA GAVETA Soporte de esquina Corner bracket	4
J3		KIT TRILHO TELESCÓPICO 350mm KIT Carril telescópico KIT Telescopic rail	1
J4		KIT TRILHO TELESCÓPICO 400mm KIT Carril telescópico KIT Telescopic rail	1
L2		SAPATA PLÁSTICA SEXTAVADA Zapato de plástico hexagonal Hexagonal plastic shoe	8
L5		BUCHA PLÁSTICA PARA SAPATA 5/16 Anclaje de plástico para zapatos Plastic shoe anchor	8

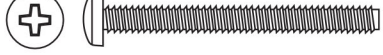
CÓD. CÓD. COD.	IMAGEM IMAGEN IMAGE	DESCRIÇÃO DESCRIPCIÓN DESCRIPTION	QTD. CTD. QTD.
B16		HASTE METÁLICA 331mm Barra de metal Metal rod	2
A13		PARAFUSO CABEÇA PANELA 4,0x30mm Tornillo de cabeza troncoconica Pan head screw	6
A17		PARAFUSO CABEÇA FLANGEADA 4,5x45mm Tornillo de cabeza bridadada Flanged head screw	8
A51		PARAFUSO CABEÇA PANELA M6x40mm Tornillo de cabeza troncoconica Pan head screw	6

PRÉ-MONTAGEM BOS1818 - BOS2018

PARA INICIAR O TRABALHO REALIZE O PROCESSO INDIVIDUAL DE CADA PEÇA COMO DEMONSTRADO NAS IMAGENS A BAIXO, APÓS SEPREARE AS PEÇAS EM UM LOCAL SEGURO.
 Para comenzar el trabajo, realice el proceso individual de cada pieza como se muestra en las imágenes a continuación.
 Luego separe las partes en un lugar seguro.
 To start the work, perform the individual process of each piece as shown in the images below.
 Then separate the parts in a safe place.

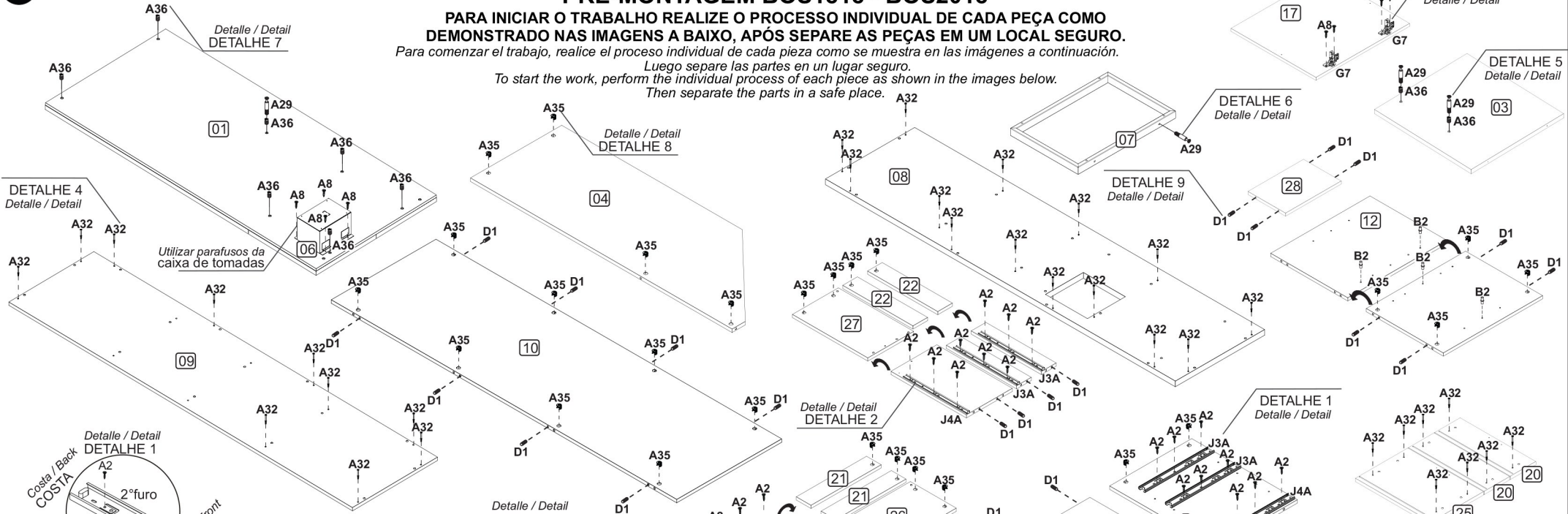

DETALHE 4
Detalle / Detail

DETALHE 7
Detalle / Detail

DETALHE 8
Detalle / Detail

DETALHE 6
Detalle / Detail

DETALHE 5
Detalle / Detail

DETALHE 9
Detalle / Detail

Utilizar parafusos da caixa de tomadas

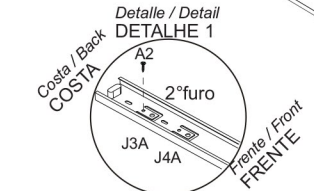

Posicione a corredeira com o 2º furo sobre a marcação de trás e parafuse. Depois posicione e parafuse na marcação de frente. Coloque a corredeira com o terceiro orifício na parte posterior e a marca del tornillo. Luego posicione y atornille la marca frontal. Position the slide with the 3rd hole on the back and screw mark. Then position and screw on the front marking.



Fixe na porta. Arreglar la puerta. Fix on the door.

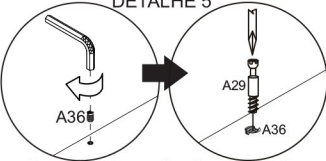

Com uma chave allen insira a bucha na peça, após, rosqueie o parafuso. Con una llave Allen, inserte el mandril en la pieza y luego atornille el tornillo. Using an Allen key, insert the chuck into the part, then screw the screw.

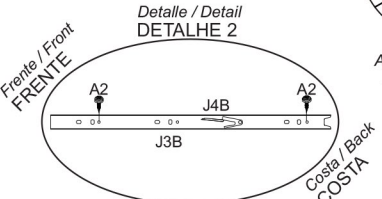

Posicione a corredeira sobre as marcações e parafuse nos furos demonstrados a cima. Coloque la corredeira sobre las marcas y atornille en los orificios que se muestran arriba. Position the slide over the markings and screw into the holes shown above.

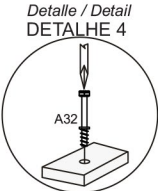

Parafuse com uma chave de fenda cruzada. Atornille con un destornillador cruzado. Screw with a crossed screwdriver.

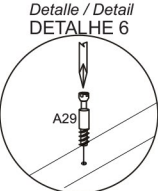

Rosqueie o parafuso. Atornille el tornillo. Insert the chuck.



Com uma chave allen insira a bucha Com una llave Allen, inserte el mandril en la. Using an Allen key, insert the chuck.

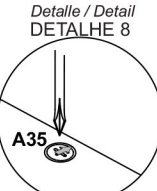

Coloque o tambor com a sua seta voltada para o parafuso. Coloque el tambor con su flecha hacia el tornillo. Place the drum with its arrow facing the screw.





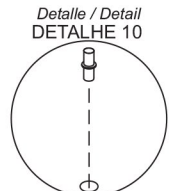







Pressione até o fundo do furo. Se necesario utilize um martelo de borracha. Presione hasta el fondo del agujero. Si es necesario, utilice un mazo de goma. Press to the bottom of the hole. If necessary use a rubber mallet.



Pressione até o fundo do furo. Se necesario utilize um martelo de borracha. Presione hasta el fondo del agujero. Si es necesario, utilice un mazo de goma. Press to the bottom of the hole. If necessary use a rubber mallet.

Accesórios utilizados:
Accesorios utilizados:
Accessories used:

- 
A35 - 36x
- 
A29 - 4x
- 
A36 - 9x
- 
D1 - 40x
- 
A2 - 36x
- 
A8 - 4x
- 
A32 - 32x
- 
B2 - 12x
- 
G7 - 2x
- 
J3 - 2x
- 
J4 - 1x

PRÉ-MONTAGEM BOS1817 - BOS2017

PARA INICIAR O TRABALHO REALIZE O PROCESSO INDIVIDUAL DE CADA PEÇA COMO DEMONSTRADO NAS IMAGENS A BAIXO, APÓS SEPRE AS PEÇAS EM UM LOCAL SEGURO.
 Para comenzar el trabajo, realice el proceso individual de cada pieza como se muestra en las imágenes a continuación.
 Luego separe las partes en un lugar seguro.
 To start the work, perform the individual process of each piece as shown in the images below.
 Then separate the parts in a safe place.

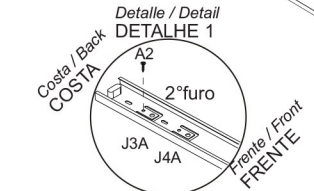
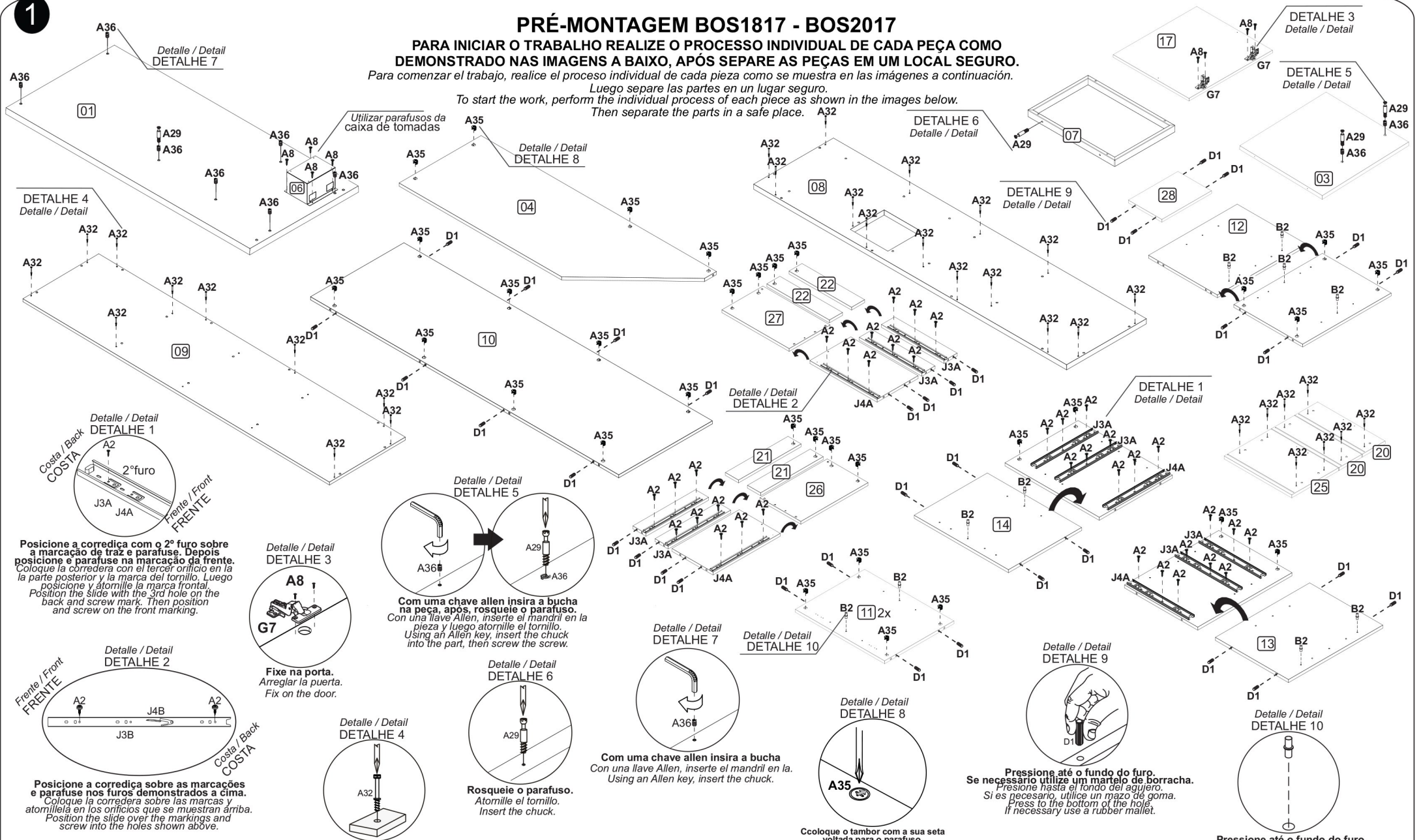

Posicione a corredeira com o 2º furo sobre a marcação de trás e parafuse. Depois posicione e parafuse na marcação de frente. Coloque a corredeira com o terceiro orifício na parte posterior e a marca del tornillo. Luego posicione y atornille la marca frontal. Position the slide with the 3rd hole on the back and screw mark. Then position and screw on the front marking.

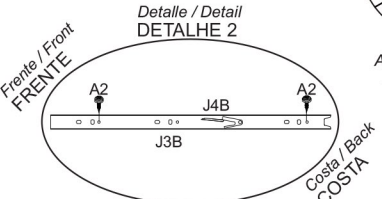

Posicione a corredeira sobre as marcações e parafuse nos furos demonstrados a cima. Coloque la corredeira sobre las marcas y atornille en los orificios que se muestran arriba. Position the slide over the markings and screw into the holes shown above.



Fixe na porta. Arreglar la puerta. Fix on the door.

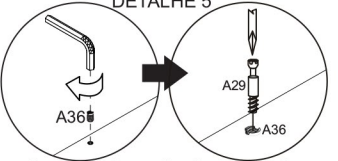

Com uma chave allen insira a bucha na peça, após, rosqueie o parafuso. Con una llave Allen, inserte el mandril en la pieza y luego atornille el tornillo. Using an Allen key, insert the chuck into the part, then screw the screw.

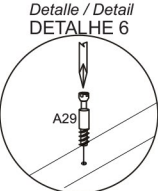

Rosqueie o parafuso. Atornille el tornillo. Insert the chuck.



Com uma chave allen insira a bucha. Con una llave Allen, inserte el mandril en la. Using an Allen key, insert the chuck.

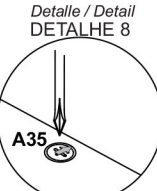

Coloque o tambor com a sua seta voltada para o parafuso. Coloque el tambor con su flecha hacia el tornillo. Place the drum with its arrow facing the screw.





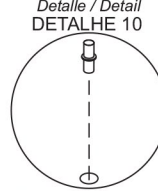







Pressione até o fundo do furo. Se necesario utilize um martelo de borracha. Presione hasta el fondo del agujero. Si es necesario, utilice un mazo de goma. Press to the bottom of the hole. If necessary use a rubber mallet.



Pressione até o fundo do furo. Se necesario utilize um martelo de borracha. Presione hasta el fondo del agujero. Si es necesario, utilice un mazo de goma. Press to the bottom of the hole. If necessary use a rubber mallet.

Acessórios utilizados:
 Accesorios utilizados:
 Accessories used:

Parafuse com uma chave de fenda cruzada. Atornille con un destornillador cruzado. Screw with a crossed screwdriver.

- 
 A35 - 36x
- 
 A29 - 4x
- 
 A36 - 9x
- 
 D1 - 40x
- 
 A2 - 36x
- 
 A8 - 4x
- 
 A32 - 28x
- 
 B2 - 12x
- 
 G7 - 2x
- 
 J3 - 2x
- 
 J4 - 1x

2 MONTAGEM EXCLUSIVO BOS1818 - BOS2018

Armado
Assembly

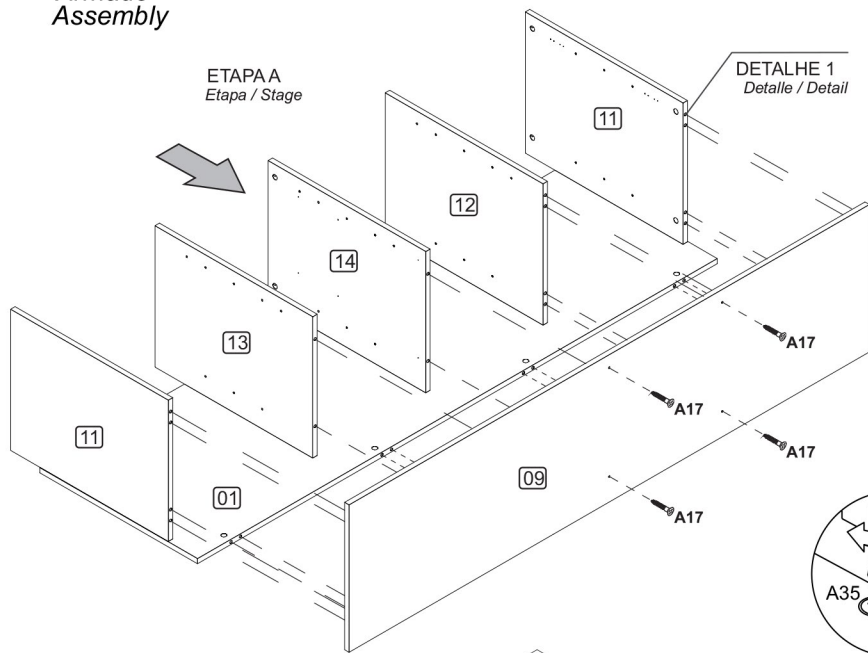

DETALHE 1
Detalle / Detail

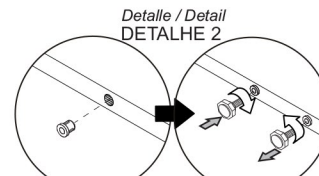

Insira a bucha com um martelo e rosqueie a sapata.
Inserte el portabrocas con un martillo y atornille la zapata.
Insert the chuck with a hammer and screw the shoe.

DETALHE 1
Detalle / Detail

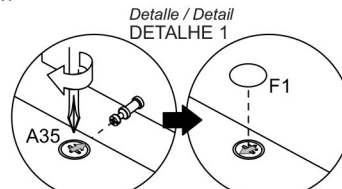

Depois de encaixar as peças coloque o tambor com a sua seta voltada para o parafuso. Para apertar Gire no sentido horário.
Después de colocar las piezas, coloque el tambor con su flecha hacia el tornillo. Para apretar, gire en sentido horario.
After fitting the parts, place the drum with its arrow facing the screw. To tighten, turn clockwise.

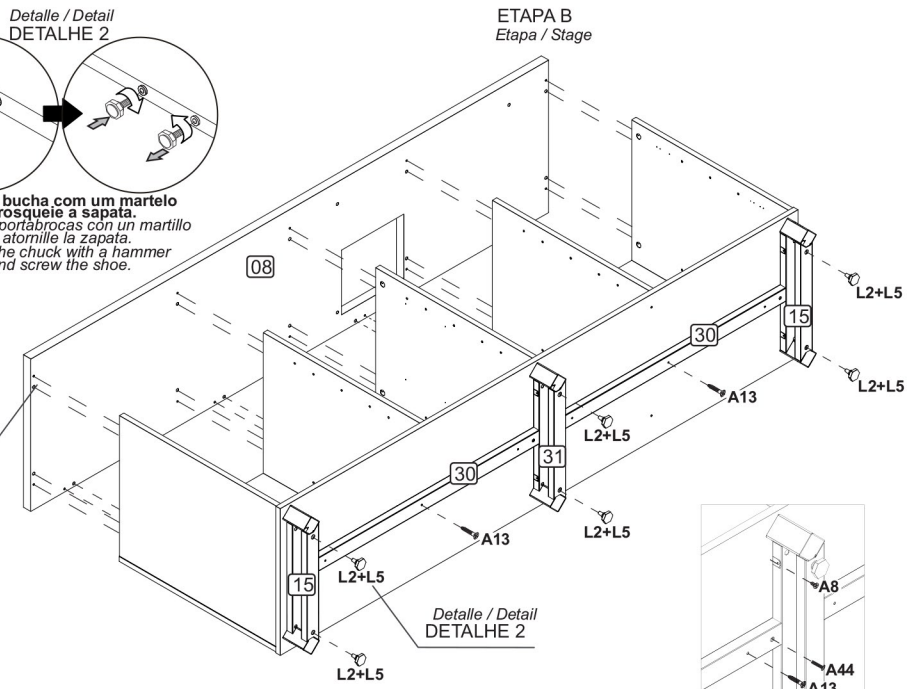

ETAPAB
Etapa / Stage

DETALHE 2
Detalle / Detail

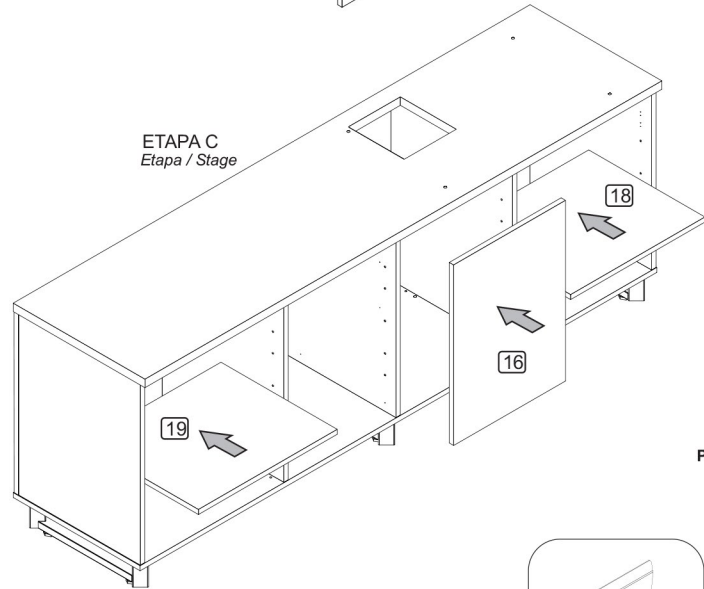

ETAPAC
Etapa / Stage

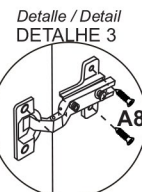



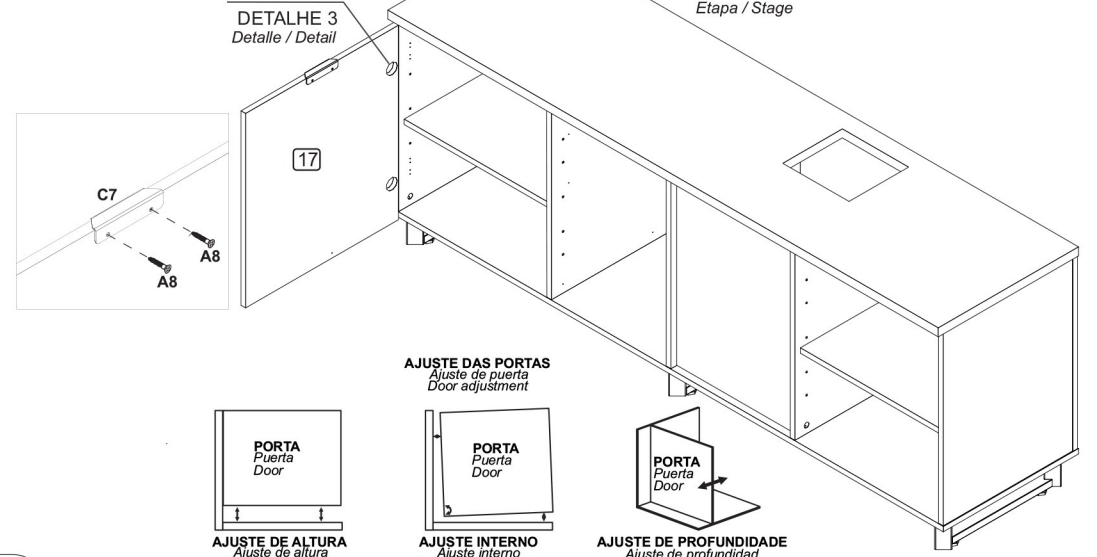

Posicione sobre as marcações.
Posición en las marcas.
Position on the markings.



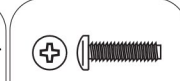

ETAPAD
Etapa / Stage

DETALHE 3
Detalle / Detail

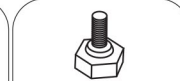
Accessories used:
Accesorios utilizados:
Accessories used:

- 
A17 - 4x
- 
A13 - 6x
- 
A44 - 4x
- 
A8 - 18x
- 
L5 - 6x
- 
L2 - 6x

- 
C7 - 1x
- 
F1 - 12x

- 
AJUSTE DE ALTURA
Ajuste de altura
Height adjustment
- 
AJUSTE INTERNO
Ajuste interno
Internal adjustment
- 
AJUSTE DE PROFUNDIDADE
Ajuste de profundidad
Depth adjustment

2 MONTAGEM EXCLUSIVO BOS1817 - BOS2017

Armado
Assembly

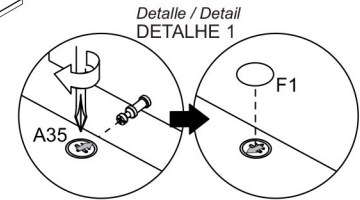
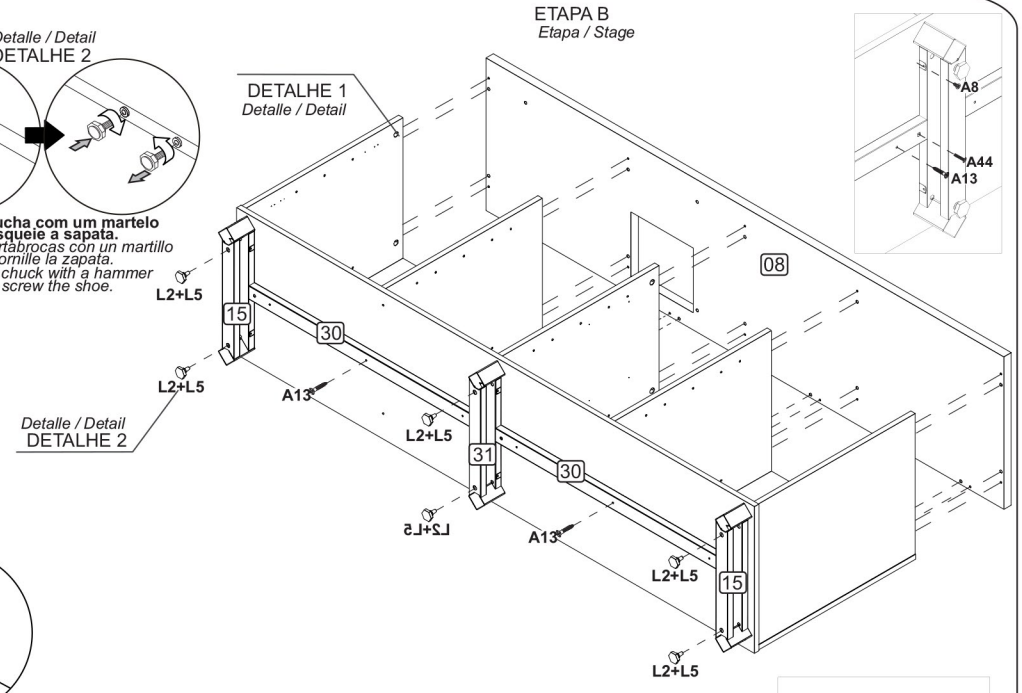
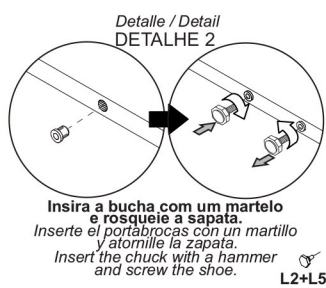
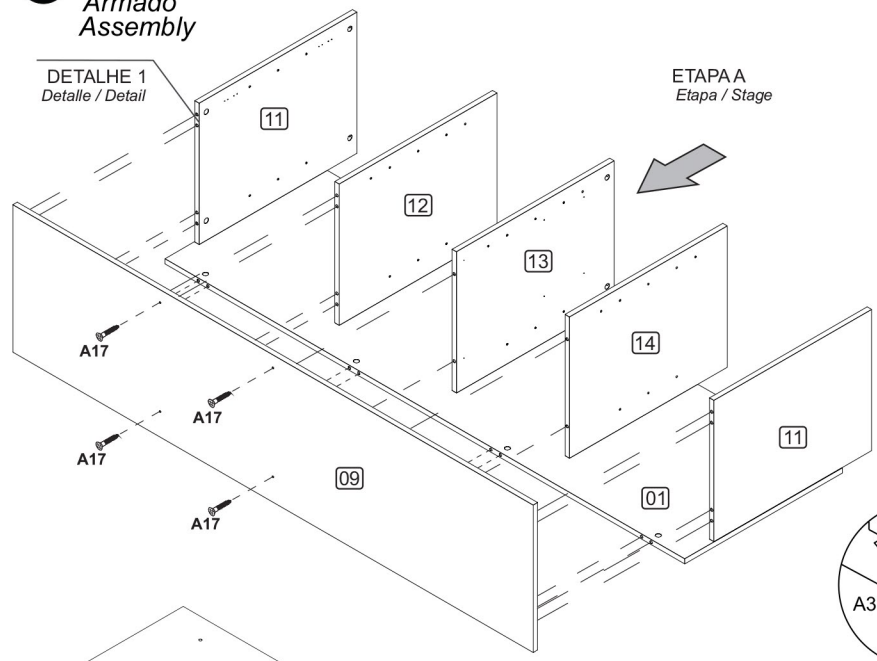

Depois de encaixar as peças coloque o tambor com a sua seta voltada para o parafuso. Para apertar Gire no sentido horário.
Después de colocar las piezas, coloque el tambor con su flecha hacia el tornillo. Para apretar, gire en sentido horario.
After fitting the parts, place the drum with its arrow facing the screw. To tighten, turn clockwise.

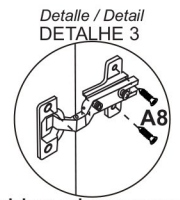
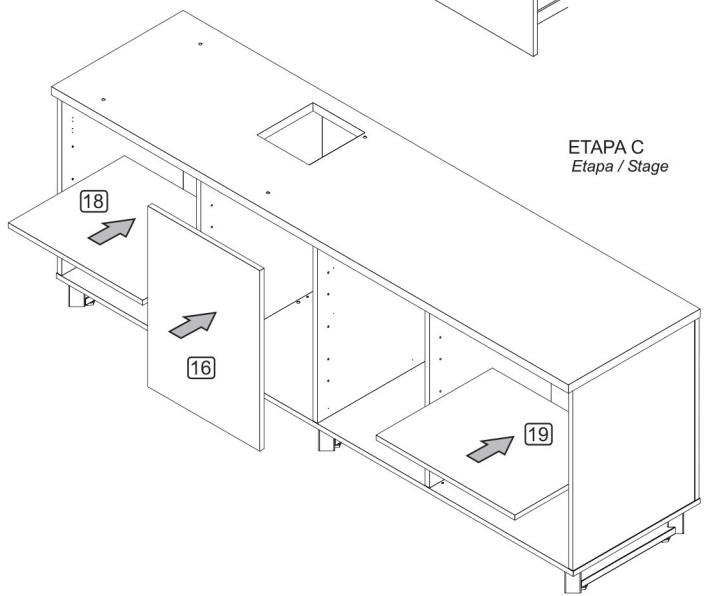



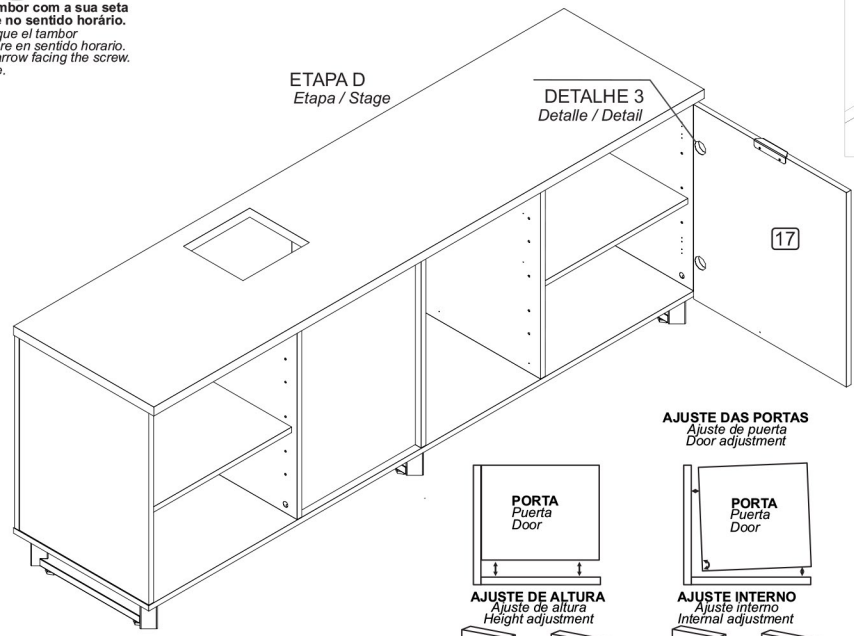

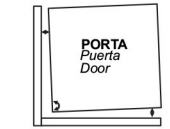
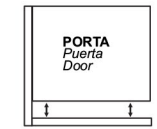

Posicione sobre as marcações
Posición en las marcas.
Position on the markings.



AJUSTE DAS PORTAS
Ajuste de puerta
Door adjustment

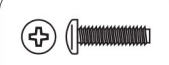

Accessories used:
Accesorios utilizados:
Accessories used:

- 
A17 - 4x
- 
A13 - 6x
- 
A44 - 4x
- 
A8 - 18x
- 
L5 - 6x
- 
L2 - 6x

3 MONTAGEM GAVETAS

Armado
Assembly

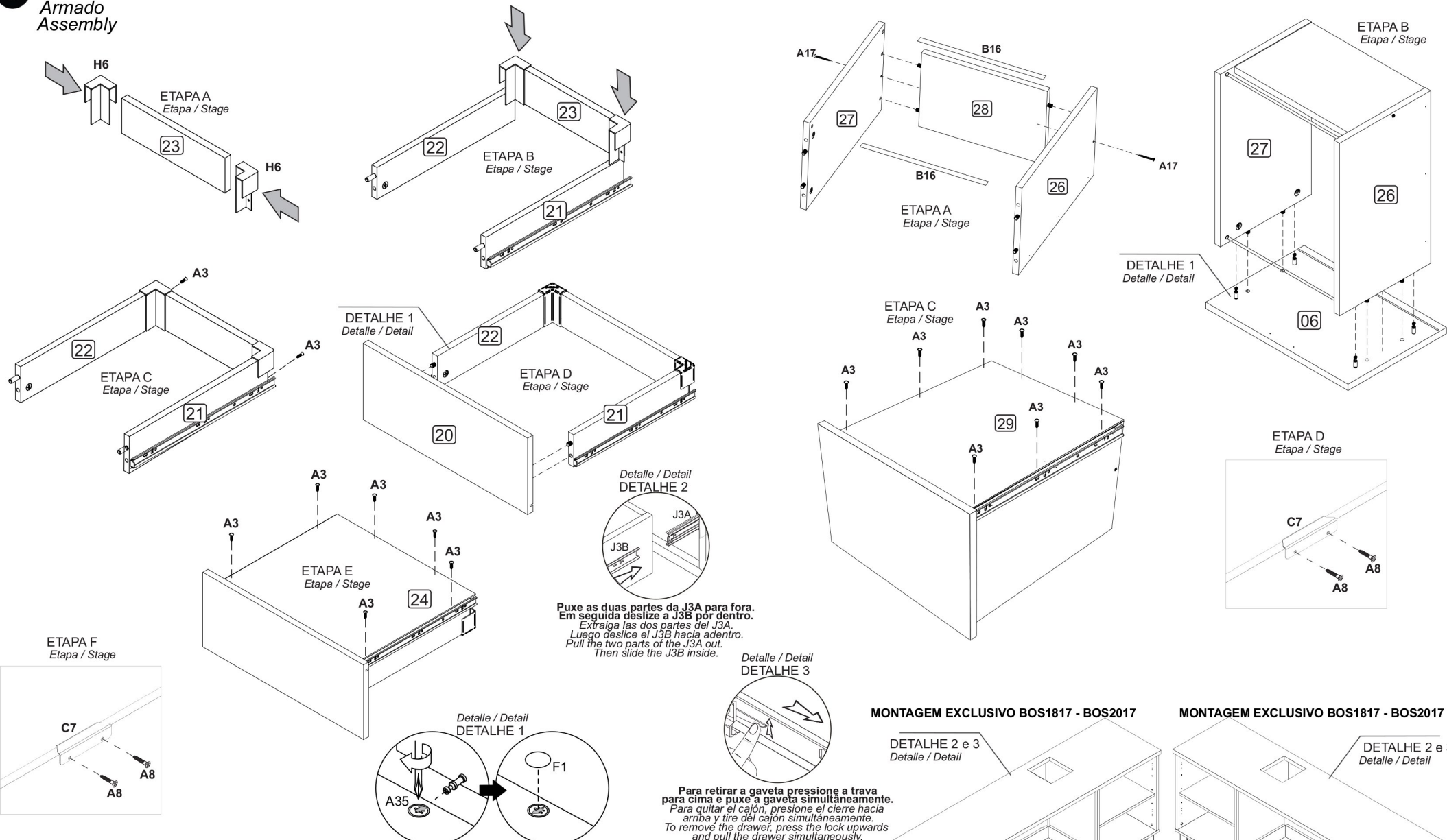





Puxe as duas partes da J3A para fora.
Em seguida deslize a J3B por dentro.
Extraiga las dos partes del J3A.
Luego deslice el J3B hacia adentro.
Pull the two parts of the J3A out.
Then slide the J3B inside.

Para retirar a gaveta pressione a trava para cima e puxe a gaveta simultaneamente.
Para quitar el cajón, presione el cierre hacia arriba y tire del cajón simultáneamente.
To remove the drawer, press the lock upwards and pull the drawer simultaneously.

Depois de encaixar as peças coloque o tambor com a sua seta voltada para o parafuso. Para apertar Gire no sentido horário.
Después de colocar las piezas, coloque el tambor con su flecha hacia el tornillo. Para apretar: gire en sentido horario.
After fitting the parts, place the drum with its arrow facing the screw. To tighten, turn clockwise.

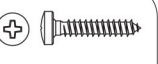
Accesórios utilizados:
Accesorios utilizados:
Accessories used:

- 
C7 - 3x
- 
F1 - 8x
- 
B16 - 2x
- 
A3 - 24x
- 
H6 - 4x
- 
A8 - 6x

MONTAGEM EXCLUSIVO BOS1817 - BOS2017

MONTAGEM EXCLUSIVO BOS1817 - BOS2017

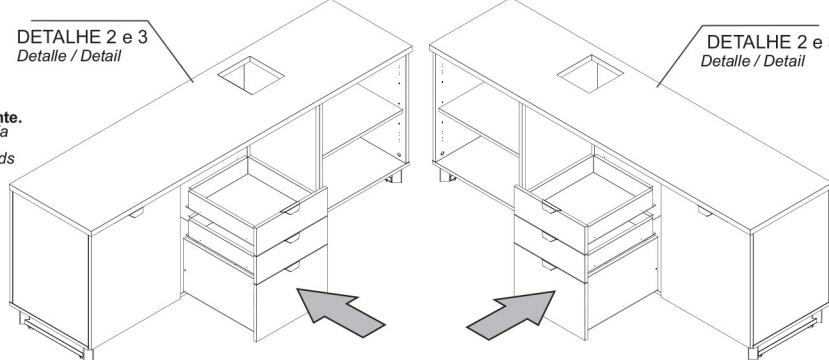

4 MONTAGEM MESA EXCLUSIVO BOS1818 - BOS1820

Armado
Assembly

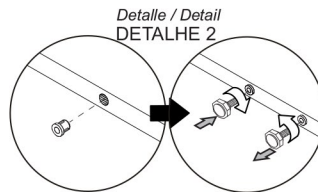
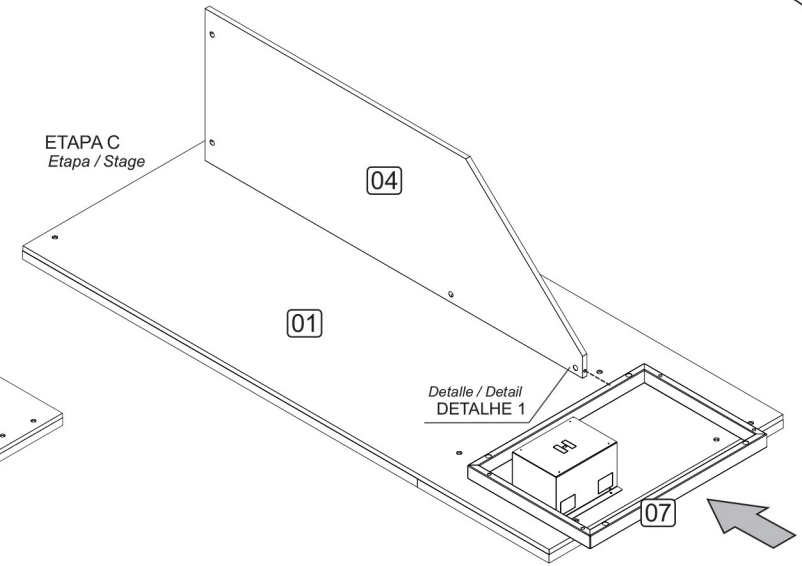
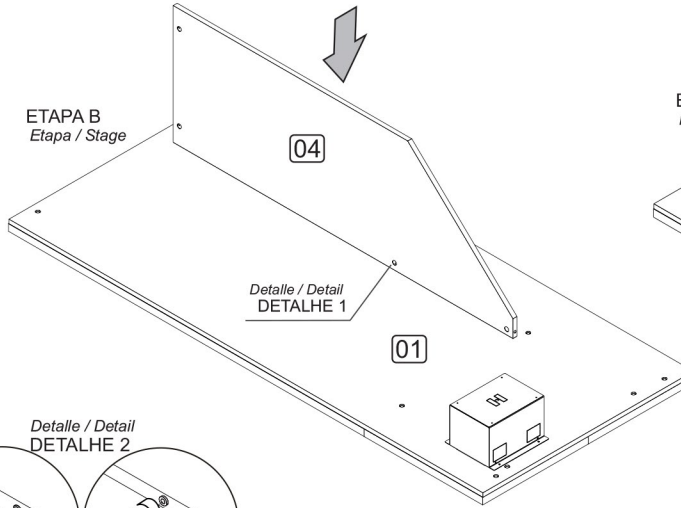
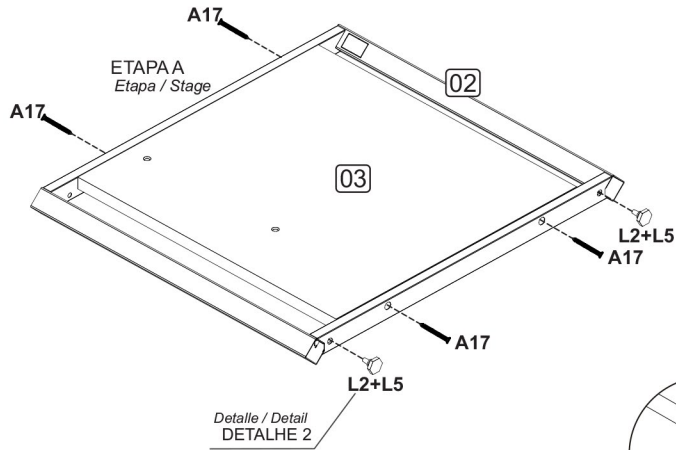

Insira a bucha com um martelo e rosqueie a sapata.
Inserte el portabrocas con un martillo y atornille la zapata.
Insert the chuck with a hammer and screw the shoe.

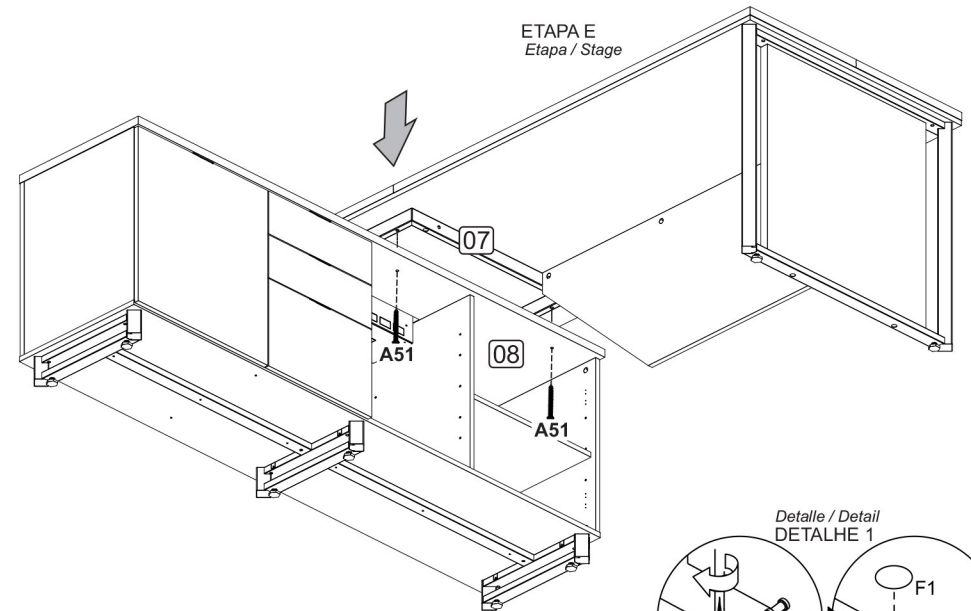
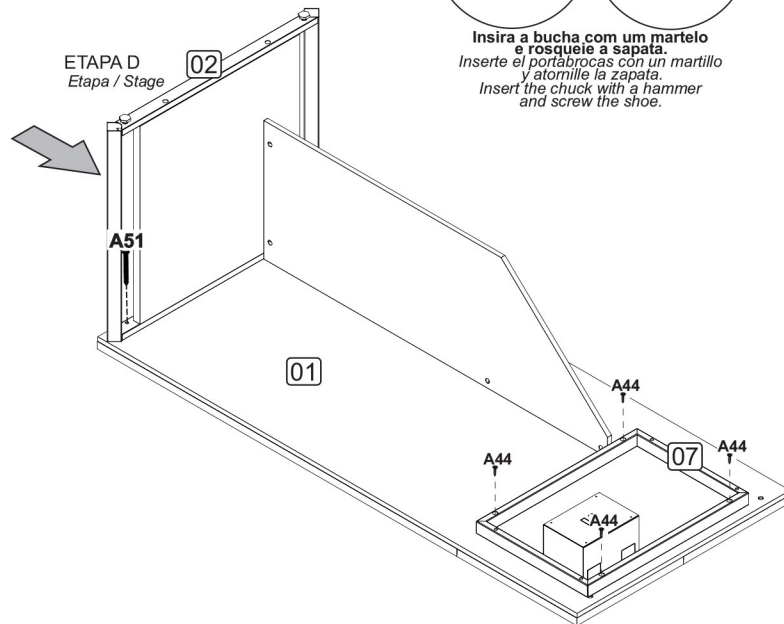

Accessórios utilizados:
Accesorios utilizados:
Accessories used:

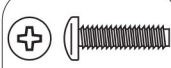

A44 - 4x



F1 - 4x



L2 - 2x



L5 - 2x



A17 - 4x



A51 - 6x

Depois de encaixar as peças coloque o tambor com a sua seta voltada para o parafuso. Para apertar Gire no sentido horário.
Después de colocar las piezas, coloque el tambor con su flecha hacia el tornillo. Para apretar, gire en sentido horario.
After fitting the parts, place the drum with its arrow facing the screw.
To tighten, turn clockwise.

5 MONTAGEM MESA EXCLUSIVO BOS1817 - BOS2017

Armado
Assembly

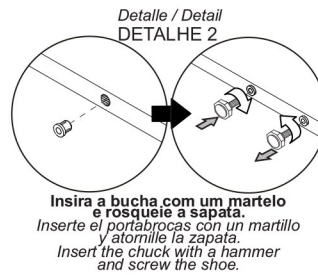
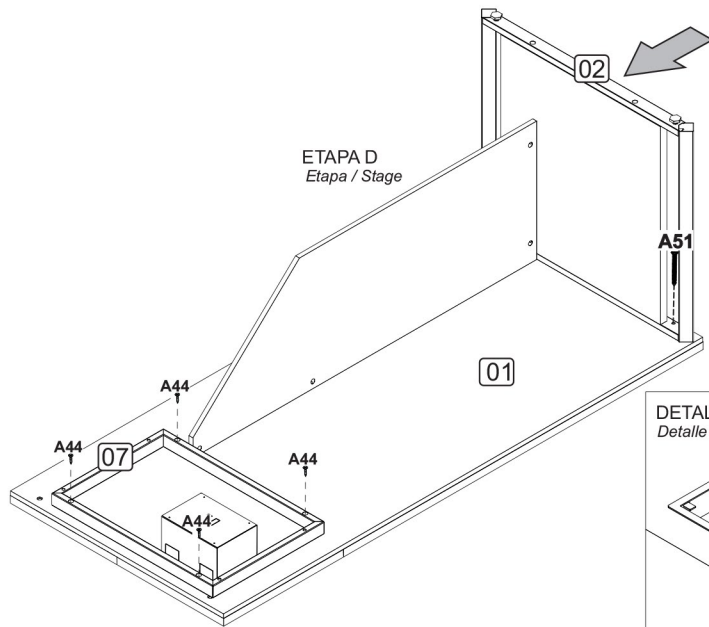
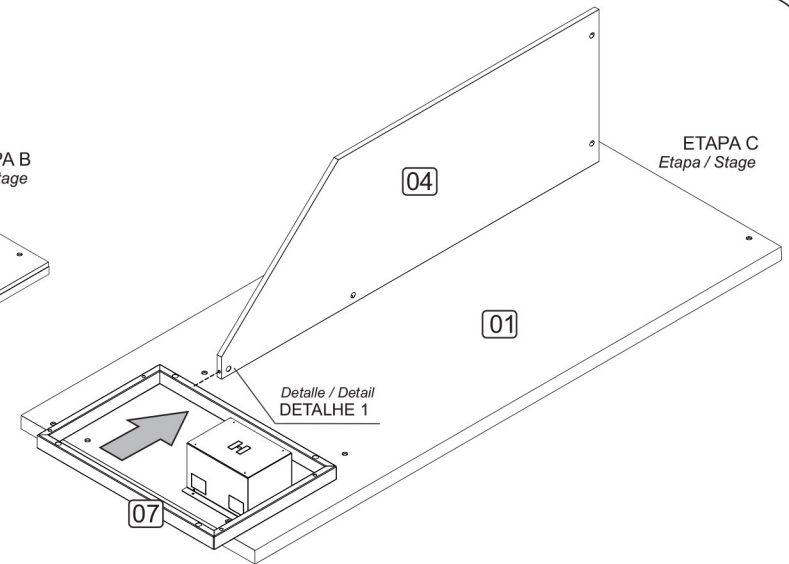
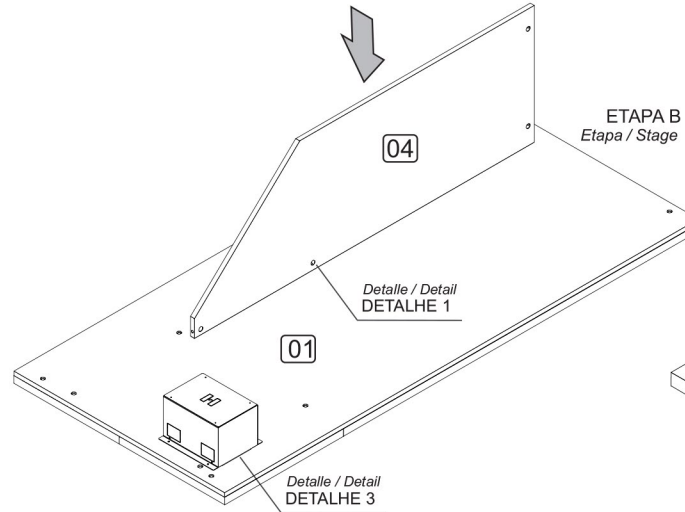
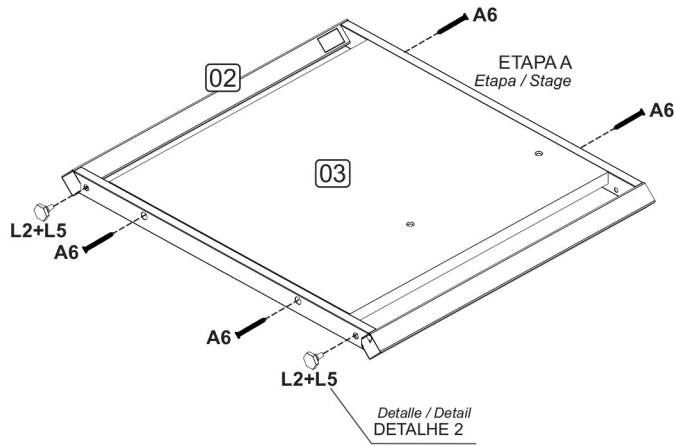

Insira a bucha com um martelo e rosqueie a sapata.
Inserte el portabrocas con un martillo y atornille la zapata.
Insert the chuck with a hammer and screw the shoe.

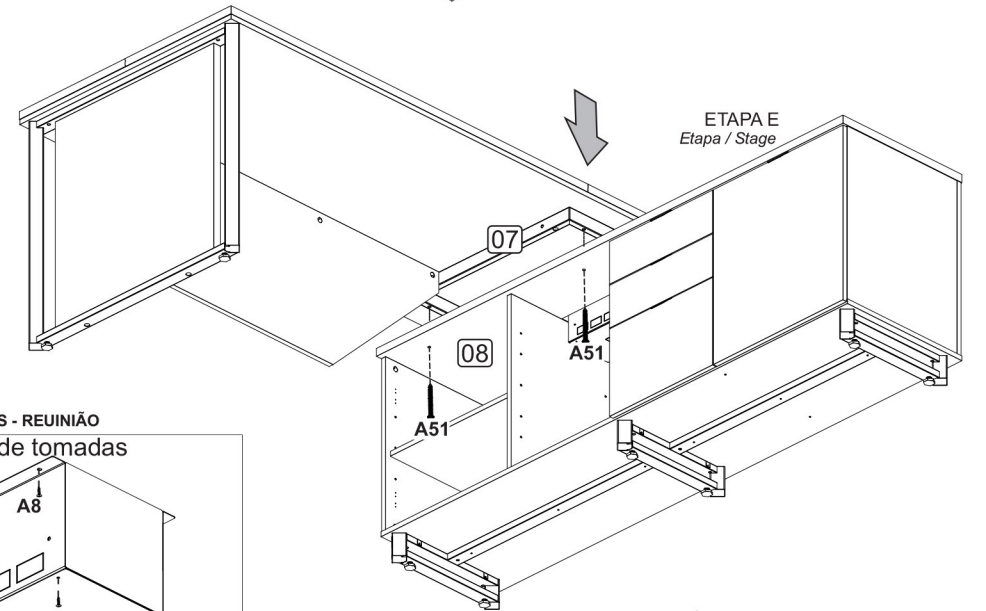

INSTALAÇÃO CAIXA DE TOMADAS LINHA BOSS - REUNIÃO

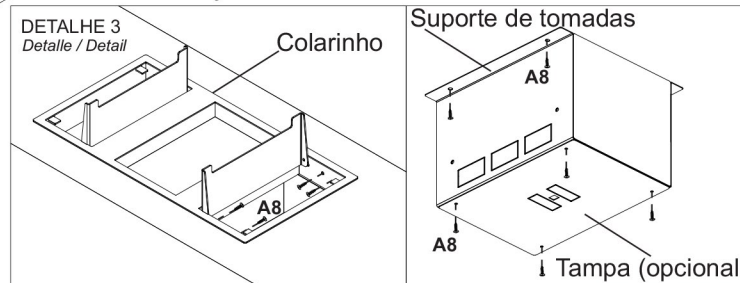

Passo 1: Posicione o colarinho sobre o tampo e parafuse nas laterais, atenção para o ALINHAMENTO E NIVELAMENTO do colarinho;
Passo 2: Posicione o suporte de tomadas em baixo do tampo e parafuse, atenção para o lado das tomadas externas;
Passo 3: Posicione a tampa em baixo do suporte, entenda que a tampa é exclusiva para MESAS DIRETOR.
Obs.: Os parafusos para instalar as caixas de tomadas Boss vem em kits separados;

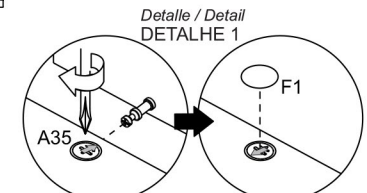

Depois de encaixar as peças coloque o tambor com a sua seta voltada para o parafuso. Para apertar Gire no sentido horário.
Después de colocar las piezas, coloque el tambor con su flecha hacia el tornillo. Para apretar, gire en sentido horario.
After fitting the parts, place the drum with its arrow facing the screw. To tighten, turn clockwise.

Acessórios utilizados:
Accesorios utilizados:
Accessories used:

