

IMPORTANTE

Por favor leia antes de prosseguir

CUIDADOS E MANUTENÇÃO

Bem-vindo

A Serpil traz até você soluções práticas de design com manuais de montagem e instalação detalhados para possibilitar o pleno aproveitamento do potencial dos produtos.

Para assegurar a garantia, é recomendada a prévia conferência de partes e componentes, bem como a leitura dos passos e suas ilustrações.

Preservar este documento é essencial para a adequada manutenção de seu móvel, o que engloba os possíveis ciclos de montagem e desmontagem.

Em caso de dúvidas, contate a Serpil que atende pelo fone 49.3366.6300 de Segunda a Sexta, das 7:30 às 11:45 e 13:30 às 18:00.

Recomendações

Para a montagem deste produto, são necessárias 2 pessoas.

Os parafusos devem ser apertados periodicamente.

Evitar batidas e o contato com objetos cortantes.

Observar as cargas máximas suportáveis, quando houver, conforme o desenho esquemático no final do documento.

Partes do produto protegidas da incidência de luz estão sujeitas a alterações de tonalidade diferentemente das expostas. Somente o uso frequente pode amenizar esta ocorrência.

Algumas pinturas novas, embora atóxicas, podem apresentar odores. Para amenizá-los, mantenha o móvel em local arejado por aproximadamente três dias.

Manutenção e Limpeza

Pano levemente umedecido com água, seguido de pano seco.



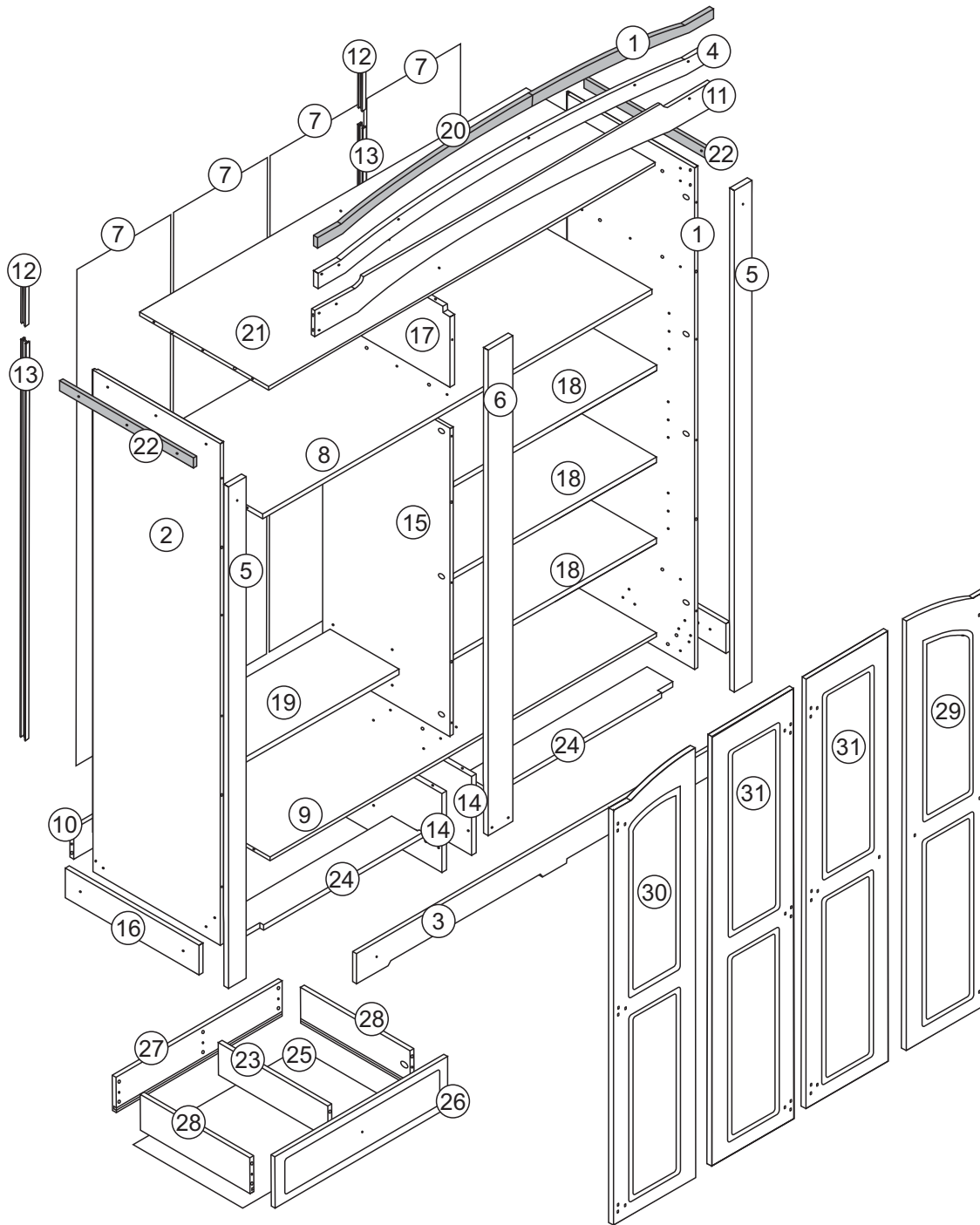











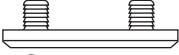













*Nunca utilizar produtos químicos ou abrasivos.

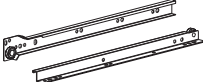

Partes do produto

Nº	Item Desc.	Qtde.	Comp.	Largu.	Espess.
1	LATERAL DIREITA ROUPEIRO	1	2040	515	15
2	LATERAL ESQUERDA ROUPEIRO	1	2040	515	15
3	RODA PE FRONTAL ROUPEIRO	1	1896	120	18
4	APLIQUE RODA FORRO ROUPEIRO	1	1823	145	15
5	MOLDURA FRONTAL LATERAL ROUPEIRO	2	2040	63	15
6	MOLDURA FRONTAL CENTRAL ROUPEIRO	1	1972	110	15
7	FUNDO TOTAL ROUPEIRO	4	1930	443	3
8	MALEIRO ROUPEIRO	1	1823	510	15
9	BASE SOBRE GAVETA ROUPEIRO	1	1823	510	15
10	RODA PE TRASEIRO ROUPEIRO	1	1830	105	15
11	RODA FORRO ROUPEIRO	1	1730	155	15
12	PERFIL H PEQUENO ROUPEIRO	2	308	55	9
13	PERFIL H GRANDE ROUPEIRO	2	1355	55	9
14	DIVISORIA INFERIOR ROUPEIRO	2	305	495	15
15	DIVISORIA CENTRAL GRANDE ROUPEIRO	1	1357	510	15
16	RODA PE INFERIOR LATERAL ROUPEIRO	2	530	120	15
17	DIVISORIA SUPERIOR ROUPEIRO	1	310	510	15
18	PRATELEIRA MOVEL ROUPEIRO	3	903	510	15
19	MEIA PRATELEIRA ROUPEIRO	1	904	220	15
20	APLIQUE FRONTAL ROUPEIRO	2	947	100	19
21	TAMPO ROUPEIRO	1	1823	495	15
22	APLIQUE LATERAL ROUPEIRO	2	530	40	19
23	DIVISORIA GAVETA ROUPEIRO	2	385	100	15
24	RIPA BASE ROUPEIRO	2	857	90	15
25	FUNDO GAVETA ROUPEIRO	2	766	398	3
26	FRENTE GAVETA ROUPEIRO	2	805	187	15
27	TRASEIRO GAVETA ROUPEIRO	2	783	150	15
28	LATERAL GAVETA ROUPEIRO	4	385	150	15
29	PORTA LATERAL DIREITA ROUPEIRO	1	1720	400	15
30	PORTA LATERAL ESQUERDA ROUPEIRO	1	1720	400	15
31	PORTA CENTRAL ESQUERDA ROUPEIRO	1	1697	400	15
32	PORTA CENTRAL DIREITA ROUPEIRO	1	1697	400	15

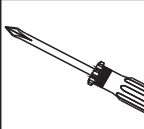
Componentes

<p>A</p>  <p>Haste Minifix (31x)</p>	<p>B</p>  <p>Tambor Minifix (31x)</p>	<p>C</p>  <p>Tapa Furo (30x)</p>
<p>D</p>  <p>Cavilha Ø 8x30mm (76x)</p>	<p>E</p>  <p>Sapata 8mm (8x)</p>	<p>F</p>  <p>Fecho Magnético (8x)</p>
<p>G</p>  <p>Dobradiça Ouro Velho (12x)</p>	<p>H</p>  <p>Puxador com Parafuso (8x)</p>	<p>I</p>  <p>Cabideiro 898mm (1x)</p>
<p>J</p>  <p>Chave Allen 3mm (1x)</p>	<p>K</p>  <p>Parafuso Soberbo (40x)</p>	<p>L</p>  <p>Parafuso Flangeado 3,5 x 16 mm (20x)</p>
<p>M</p>  <p>Parafuso Chato Ø 3 x 12 mm (38x)</p>	<p>N</p>  <p>Parafuso Panela Ouro Velho Ø 3,5x14 (72x)</p>	<p>O</p>  <p>Prego 10 x 10mm (70x)</p>
<p>P</p>  <p>Cola (2x)</p>	<p>Q</p>  <p>Suporte Cabideiro cromado (2x)</p>	<p>R</p>  <p>Tachão Ouro Velho (4x)</p>
<p>S</p>  <p>Espaçador de Porta (2x)</p>	<p>T</p>  <p>Cavilha Ø 8x50mm (2x)</p>	<p>U</p>  <p>Parafuso Chato Ø 4 x 40mm (4x)</p>
<p>V</p>  <p>Suporte Prateleira cromado (16x)</p>	<p>X</p>  <p>Chapinha Fixação fundo total (11x)</p>	<p>W</p>  <p>Corrediça 400mm (2xPar)</p>
<p>Y</p>  <p>Espaçador de Gaveta (6x)</p>	<p>Z</p>  <p>Parafuso Bujão 6x12mm (6x)</p>	<p>AA</p>  <p>Parafuso Bujão Chato 6x10mm (6x)</p>
<p>AB</p>  <p>Parafuso Flangeado 3,5 x 25 mm (19x)</p>	<div style="display: flex; justify-content: space-around; align-items: center;"> <div data-bbox="1155 1973 1342 2145">  <p>USE</p> </div> <div data-bbox="1369 1816 1501 2145">   <p>NÃO USE</p> </div> </div>	

Pré - Montagem

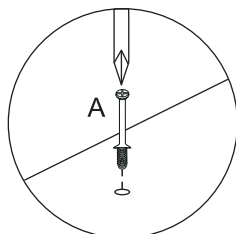
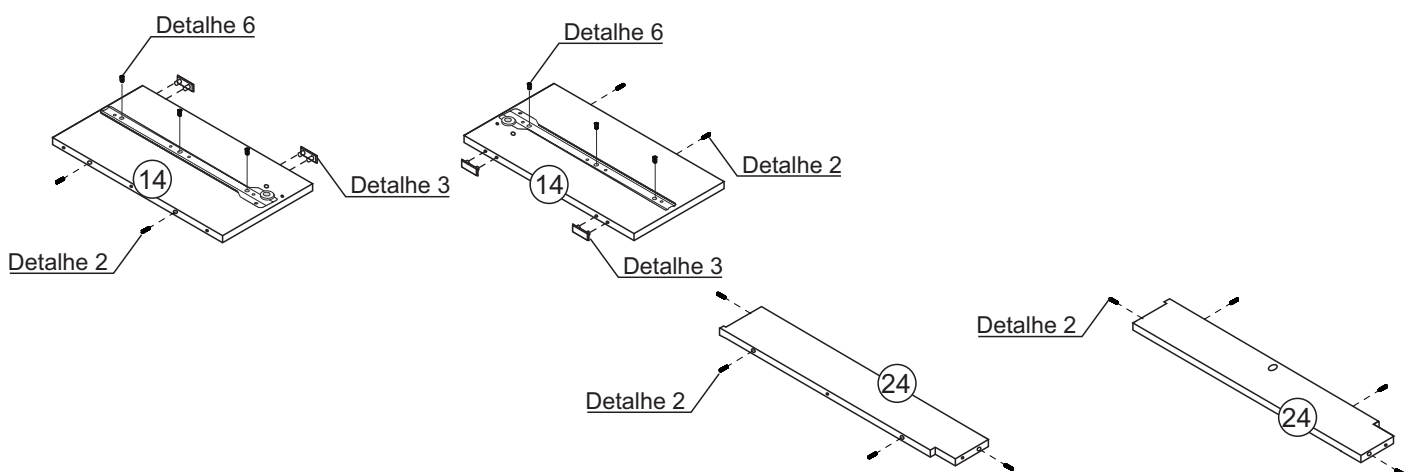
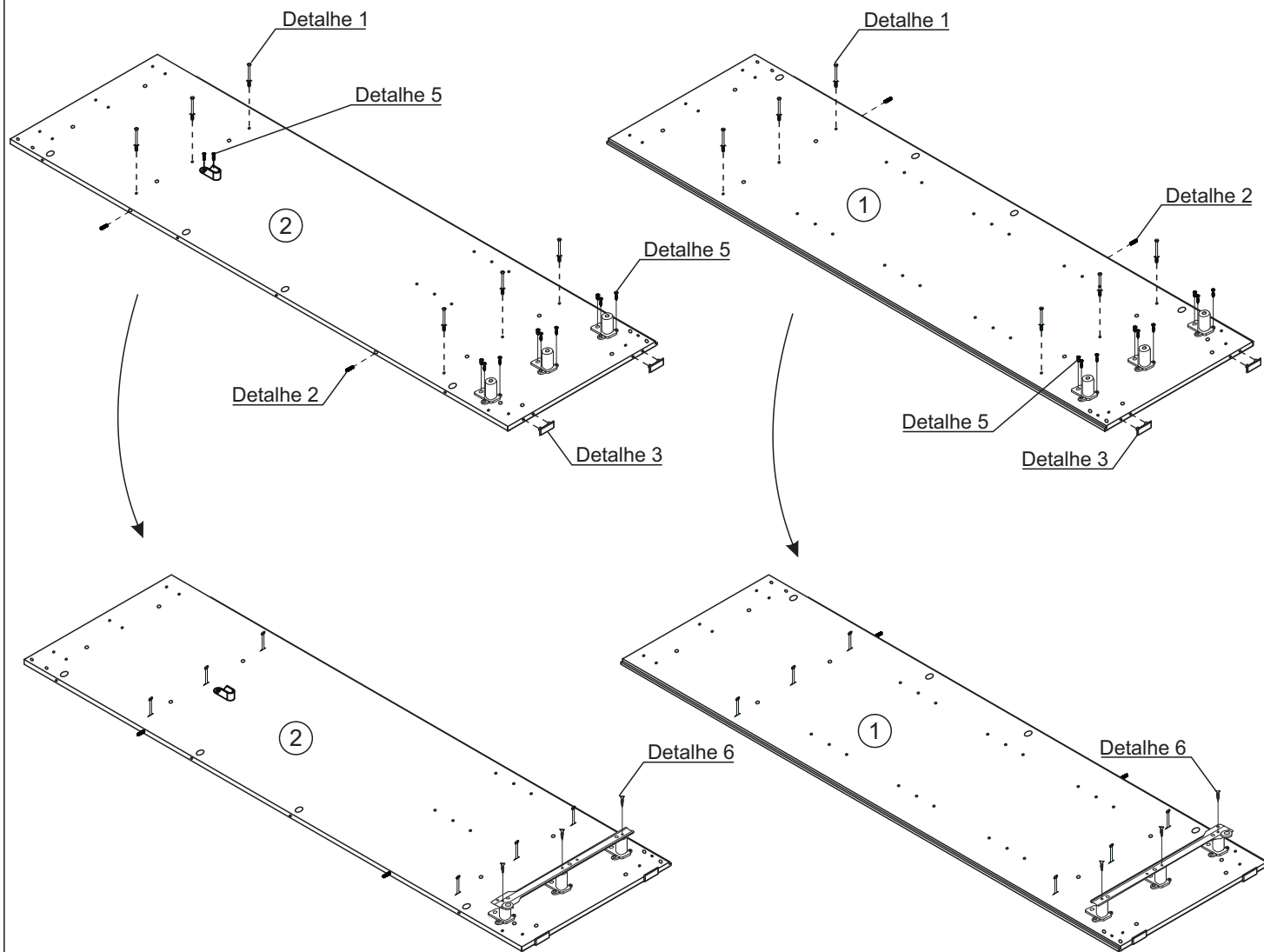

Detalhe 1

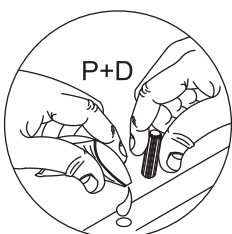

Detalhe 2

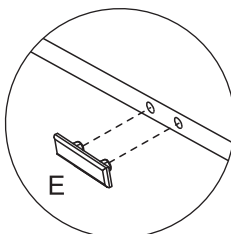

Detalhe 3

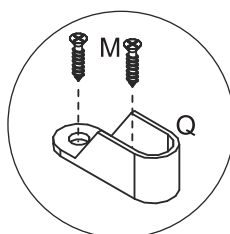

Detalhe 4

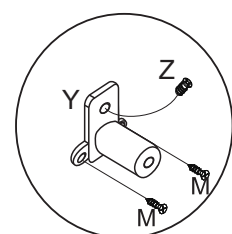

Detalhe 5

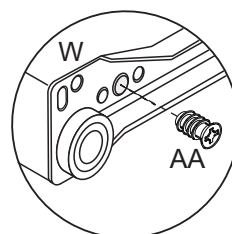

Detalhe 6

Pré - Montagem

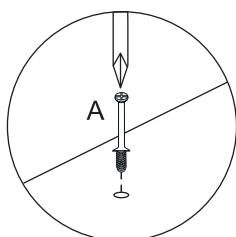
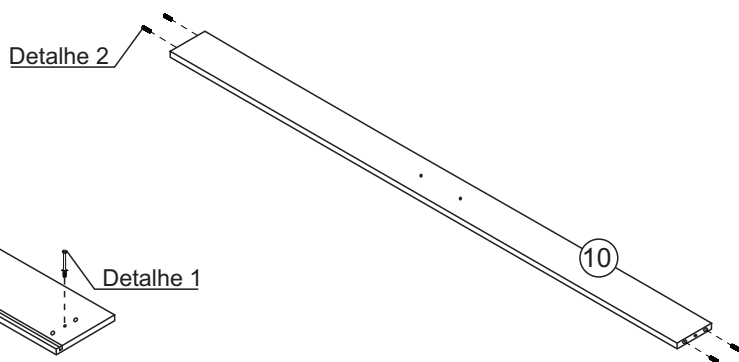
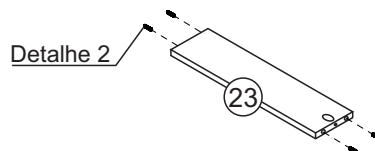
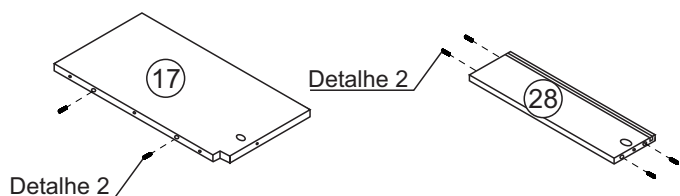
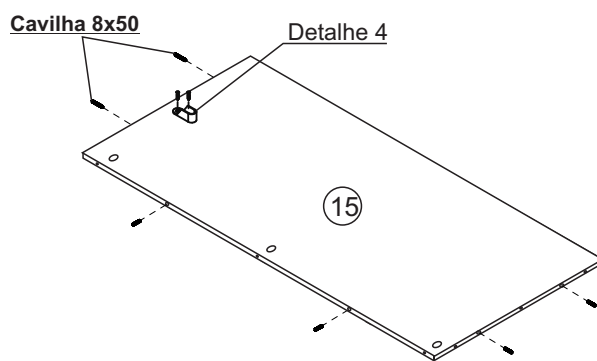
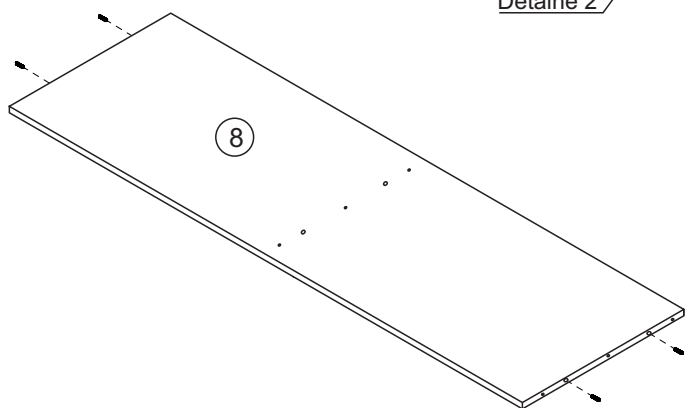
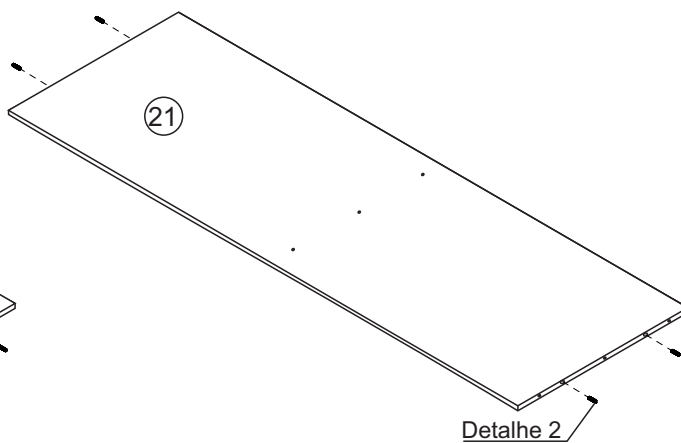
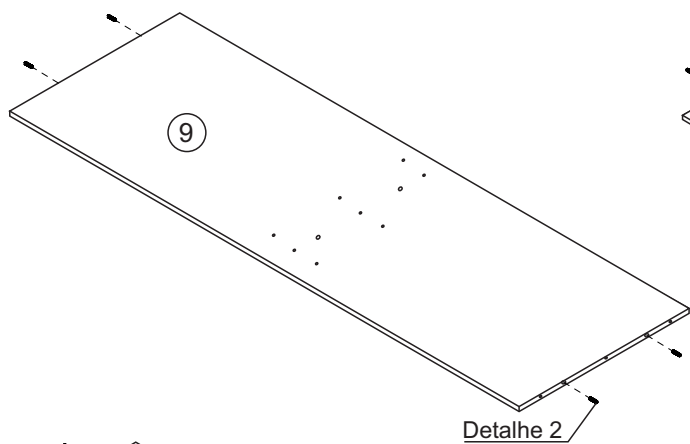

Detalhe 1



Detalhe 2

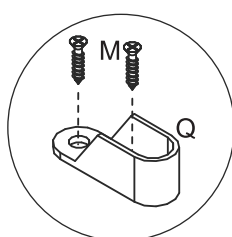

Detalhe 4

Pré - Montagem

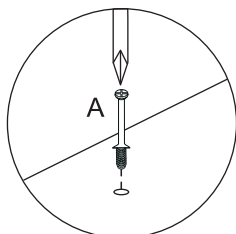
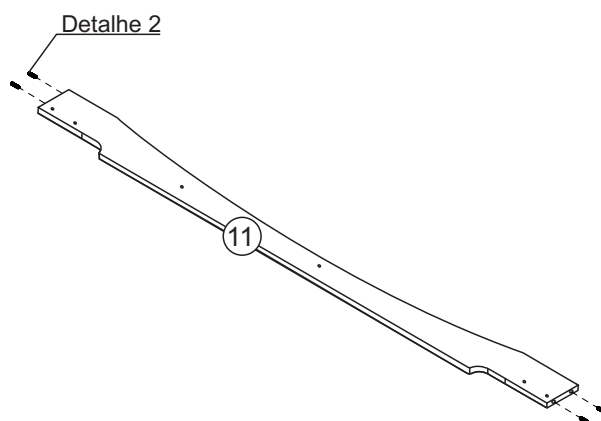
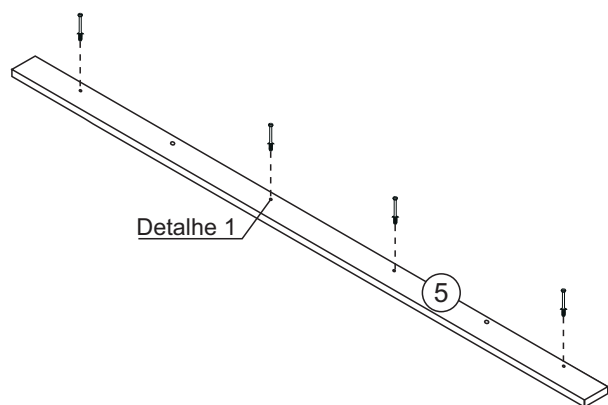
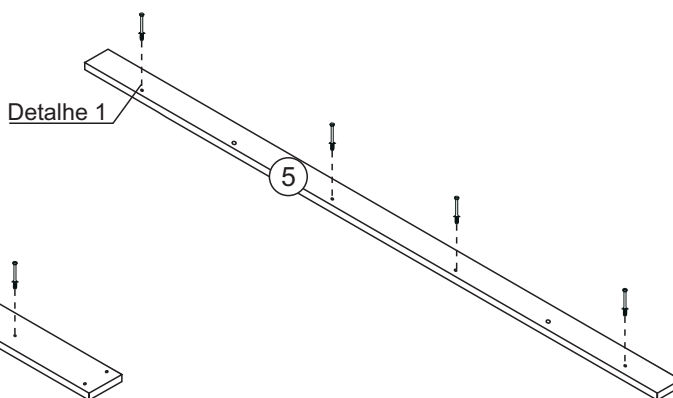
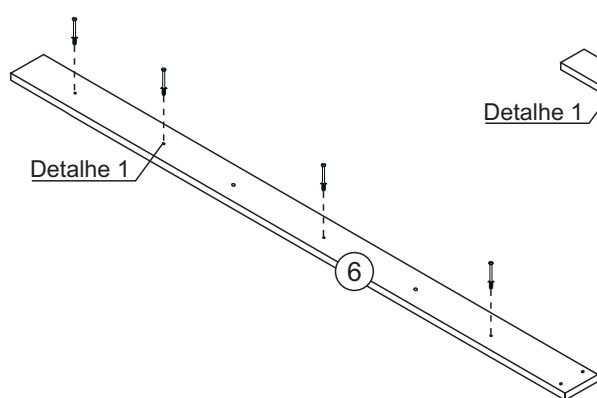



Detalhe 1



Detalhe 2

1

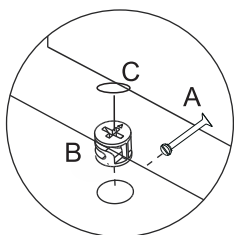
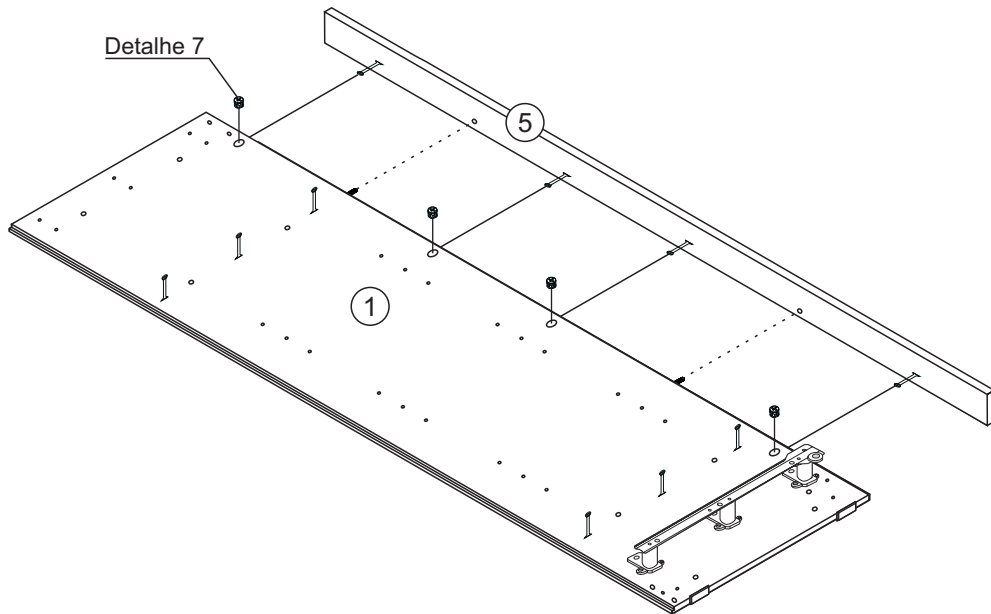

	
A- Haste Minifix (4x)	C- Tapa Furo (4x)



Detalhe 7

Encaixar e Girar os
tambores em sentido
horário.

2

	
A- Haste Minifix (4x)	C- Tapa Furo (3x)

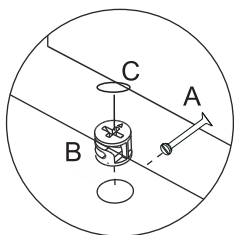
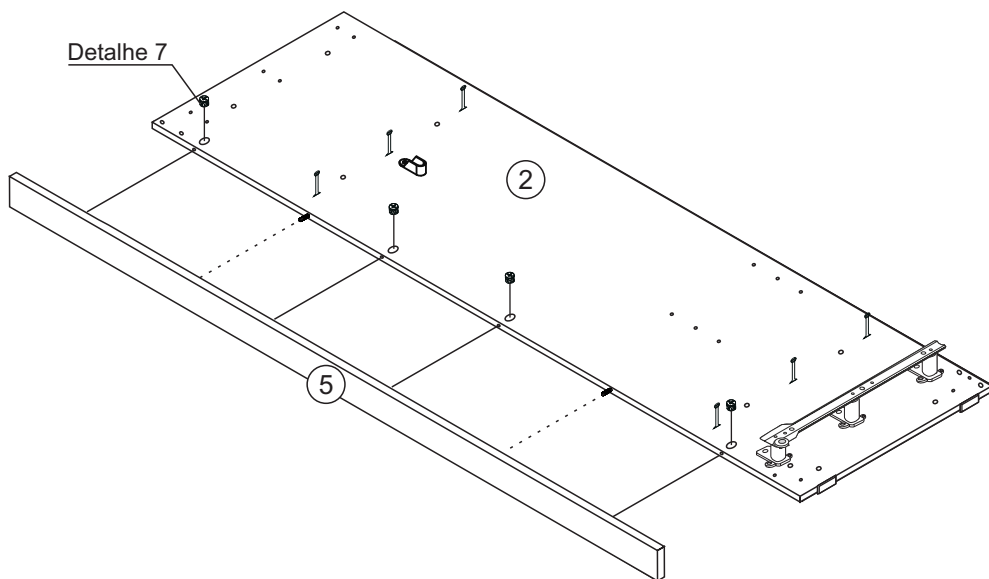

Detalhe 7

Encaixar e Girar os
tambores em sentido
horário.

3



A- Haste Minifix (5x)



C- Tapa Furo (5x)



K- Parafuso Soberbo (3x)



J- Chave Allen 3mm (1x)

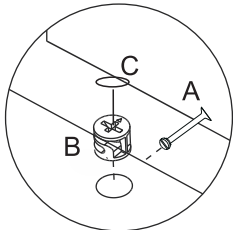

Detalhe 7

Encaixar e girar os tambores em sentido horário.

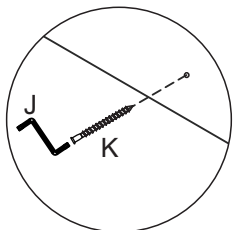

Detalhe 8

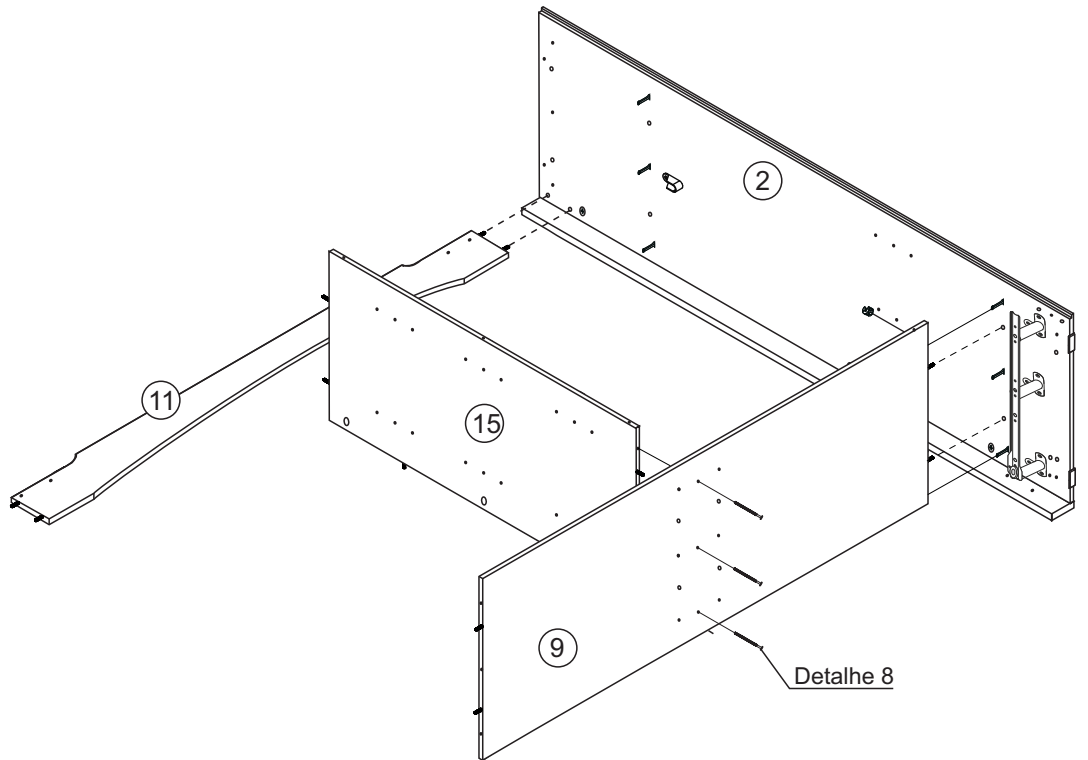

4



K- Parafuso Soberbo (2x)

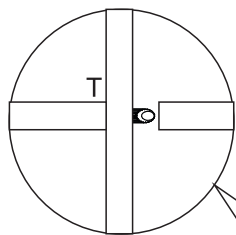



Cavilha 8x50

K

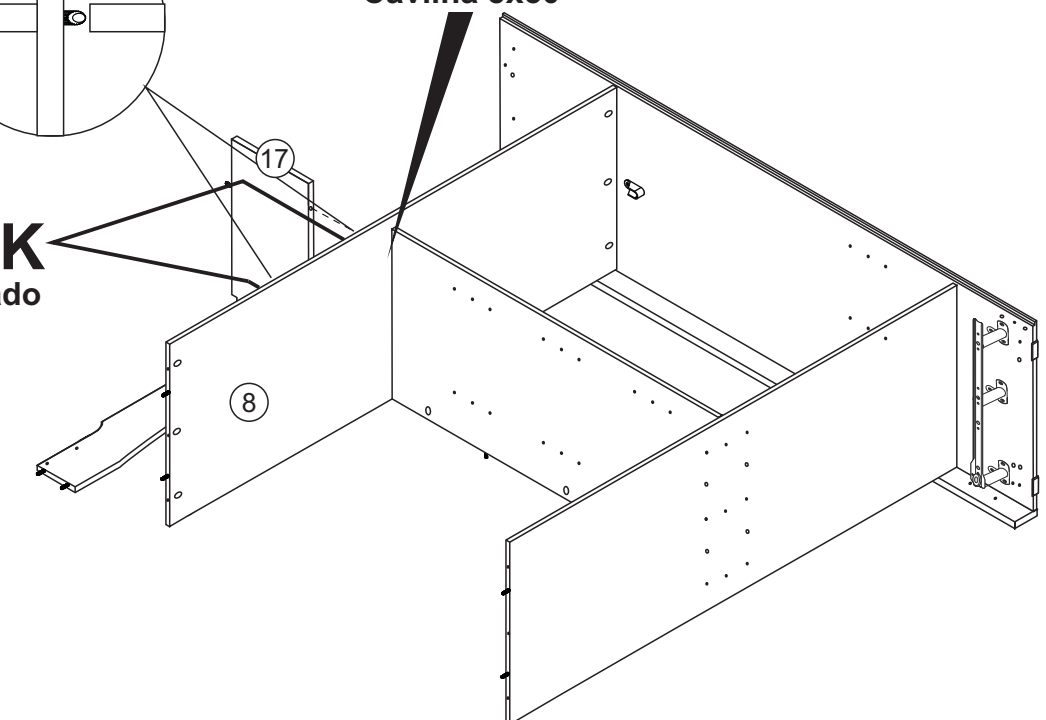
Parafuso fixado na peça *15*



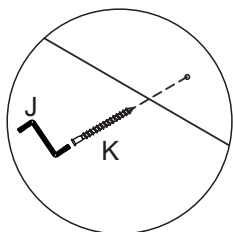
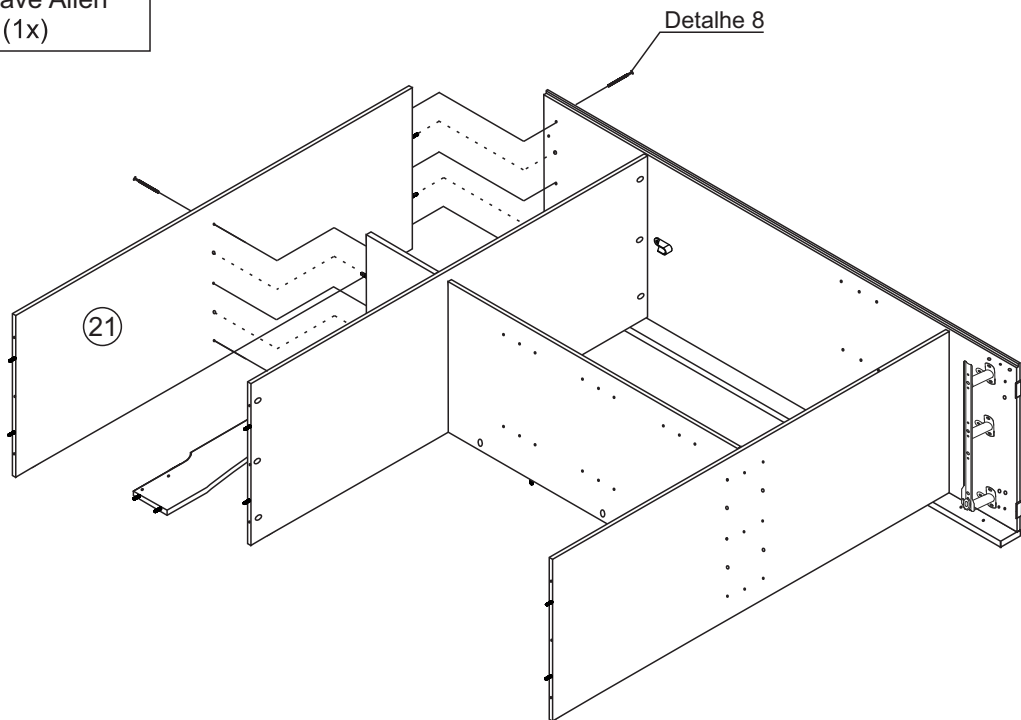

5

 <p>K- Parafuso Soberbo (6x)</p>	 <p>J- Chave Allen 3mm (1x)</p>
---	---



Detalhe 8

6

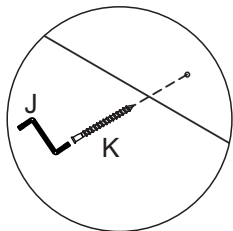
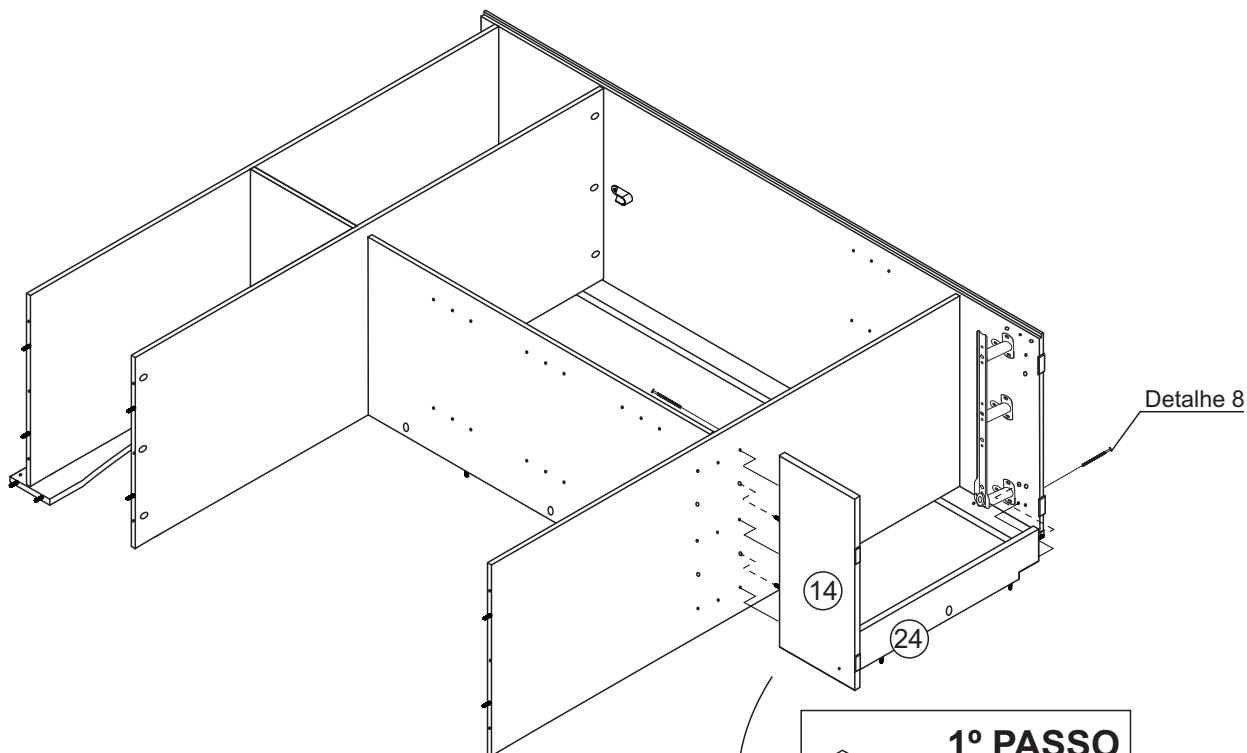

 <p>K- Parafuso Soberbo (4x)</p>	 <p>J- Chave Allen 3mm (1x)</p>
---	---

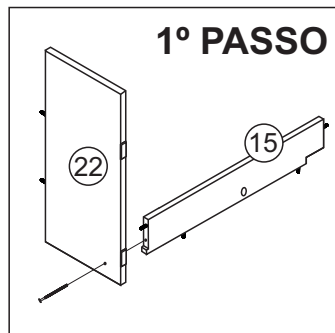

Detalhe 8



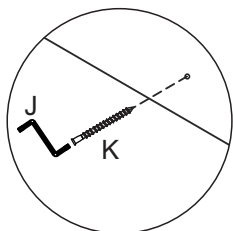
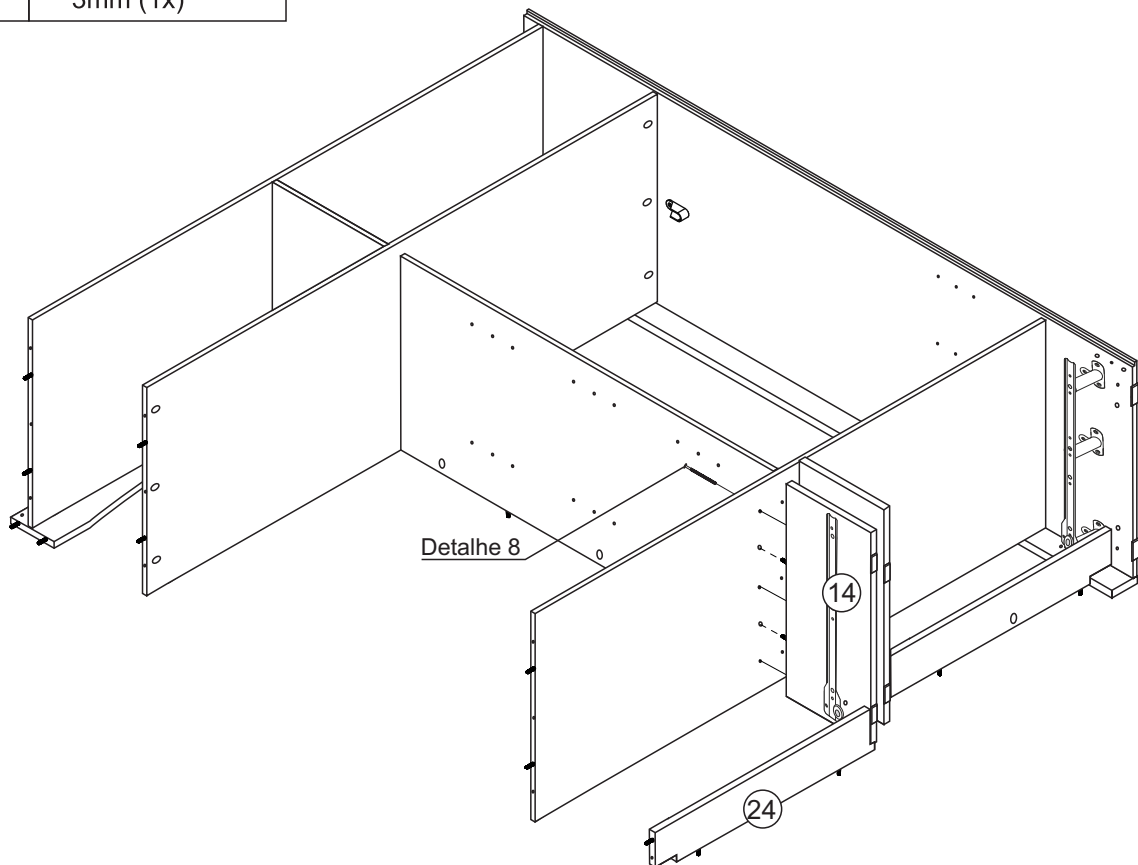

7

 K- Parafuso Soberbo (3x)	 J- Chave Allen 3mm (1x)
--	--



Detalhe 8

8

 K- Parafuso Soberbo (3x)	 J- Chave Allen 3mm (1x)
--	---

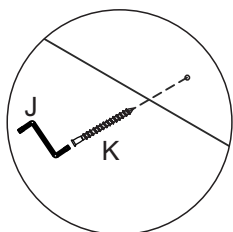
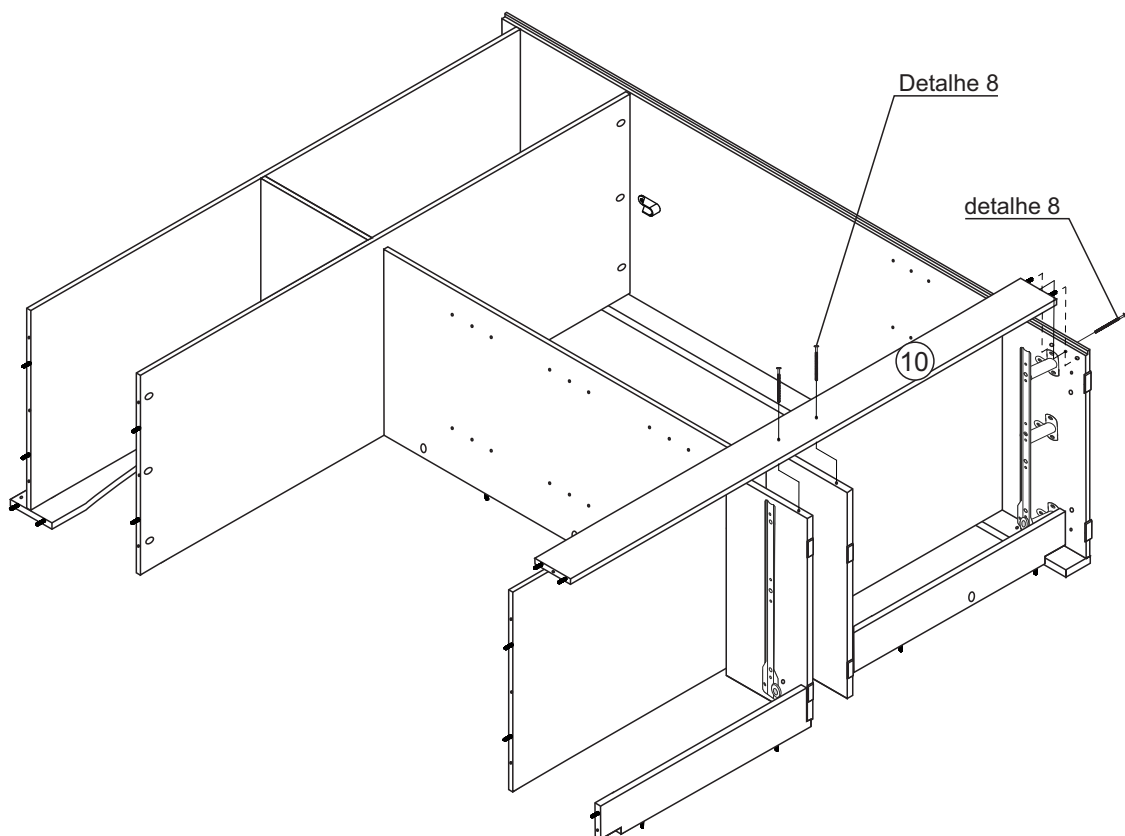

Detalhe 8

9



A- Haste Minifix
(6x)



C- Tapa Furo
(6x)



K- Parafuso Soberbo
(5x)



J- Chave Allen
3mm (1x)

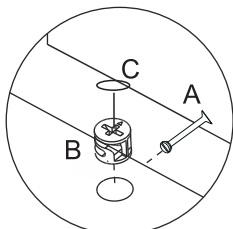

Detalhe 7

Encaixar e Girar os
tambores em sentido
horário.

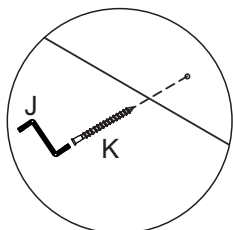

Detalhe 8

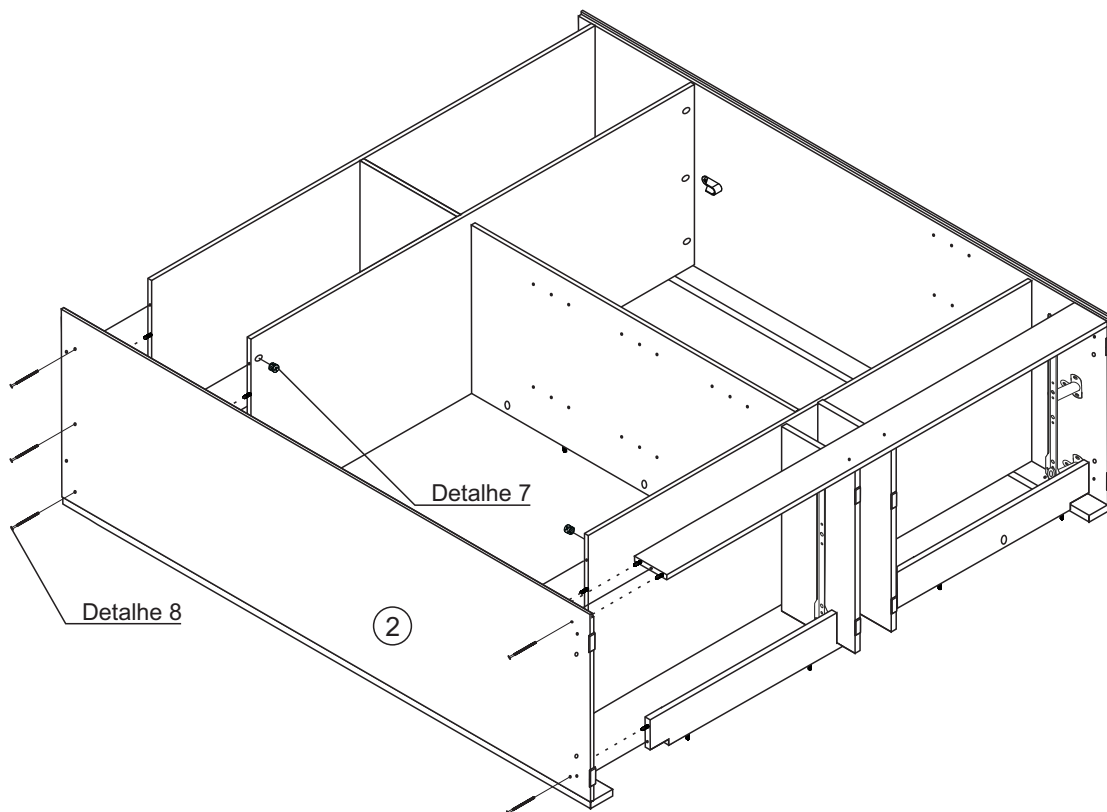

10



A- Haste Minifix
(4x)



C- Tapa Furo
(4x)

***Gire o produto pra este passo.**

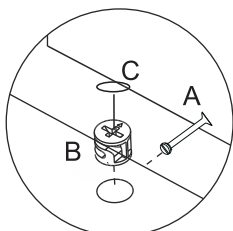

Detalhe 7

Encaixar e Girar os
tambores em sentido
horário.

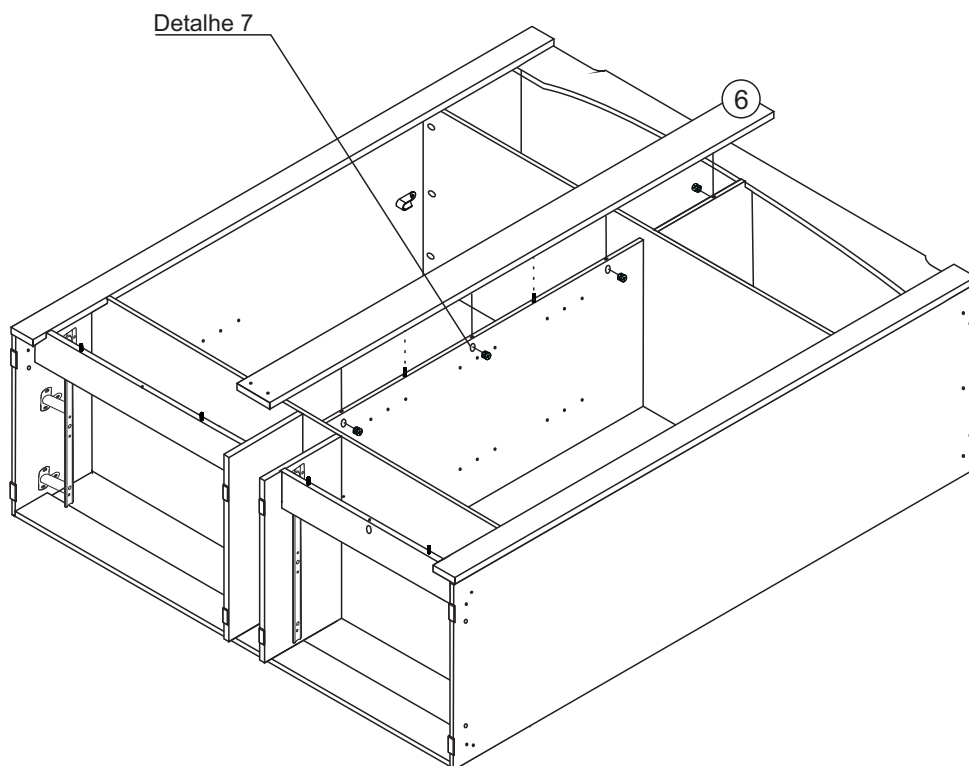

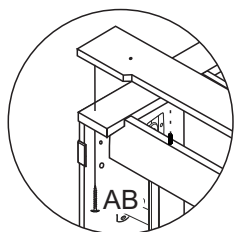
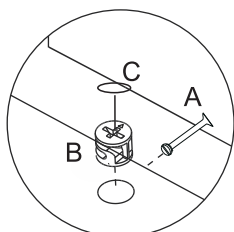
11A- Haste Minifix
(2x)C- Tapa Furo
(2x)AB -Parafuso FL
Ø3,5 x 25mm (4x)**Detalhe 9****Detalhe 7**Encaixar e Girar os
tambores em sentido
horário.

Detalhe 9

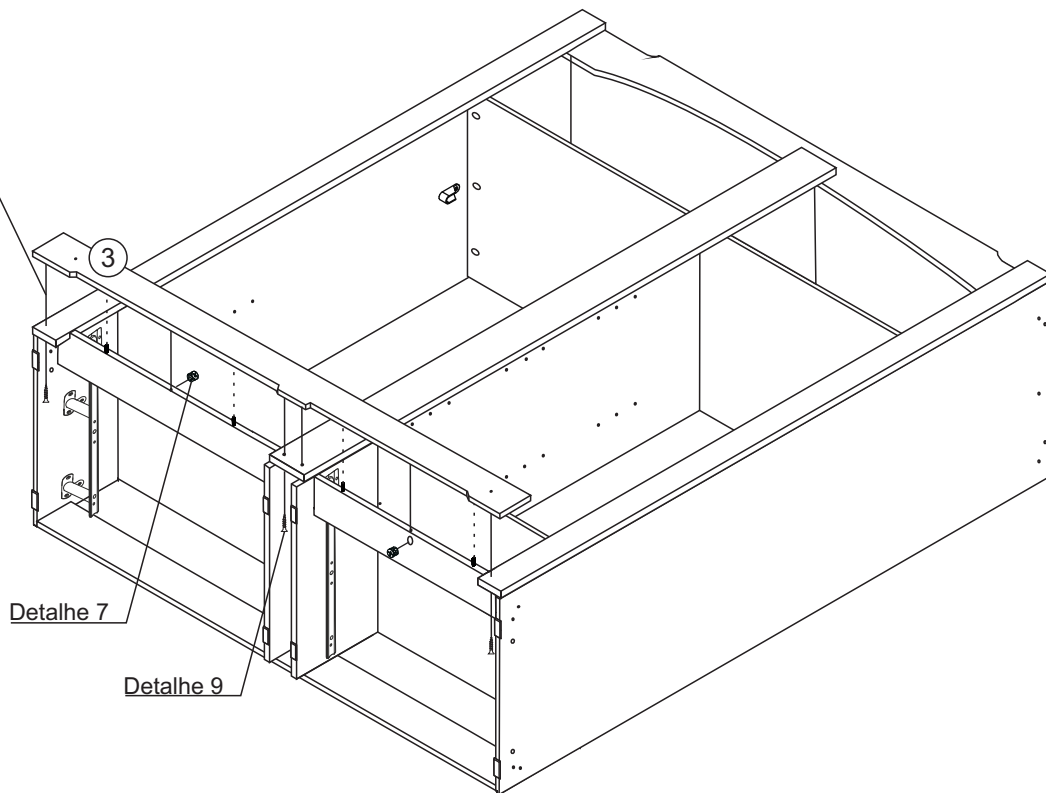

Detalhe 7

Detalhe 9

12AB -Parafuso FL
Ø3,5 x 25mm (4x)

Detalhe 9

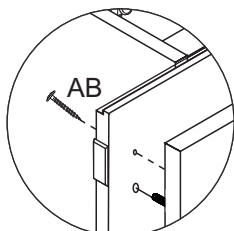
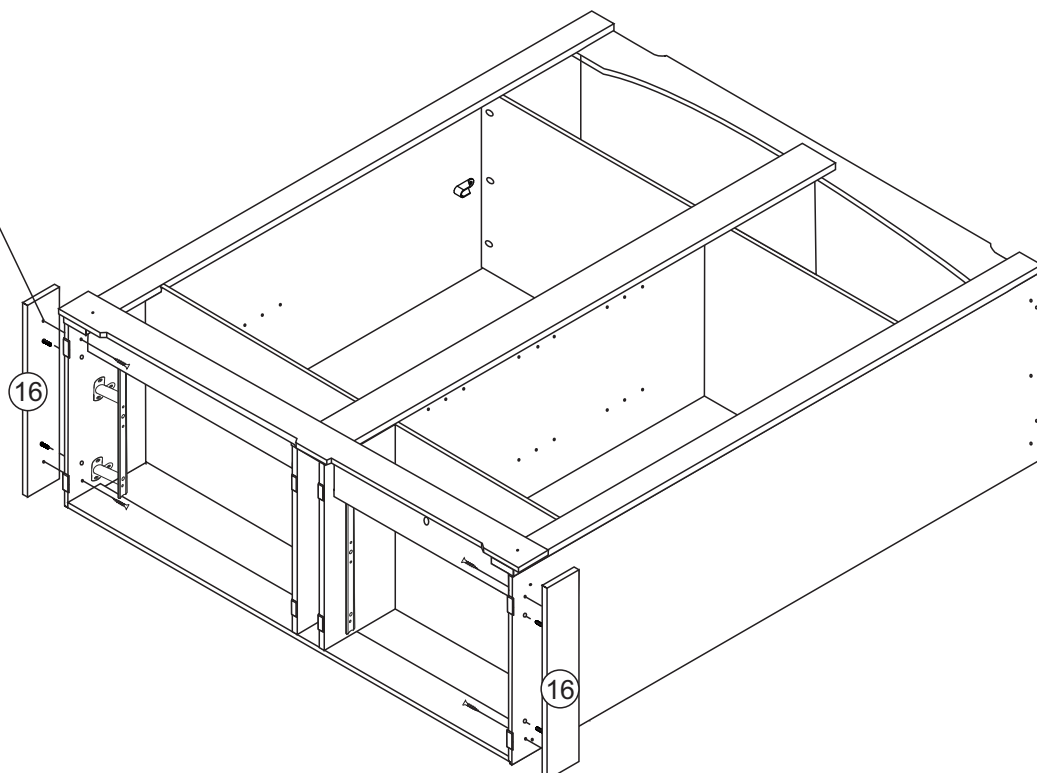
**Detalhe 9**

13



AB- Parafuso Flangeado
3,5 x 25 mm (4x)

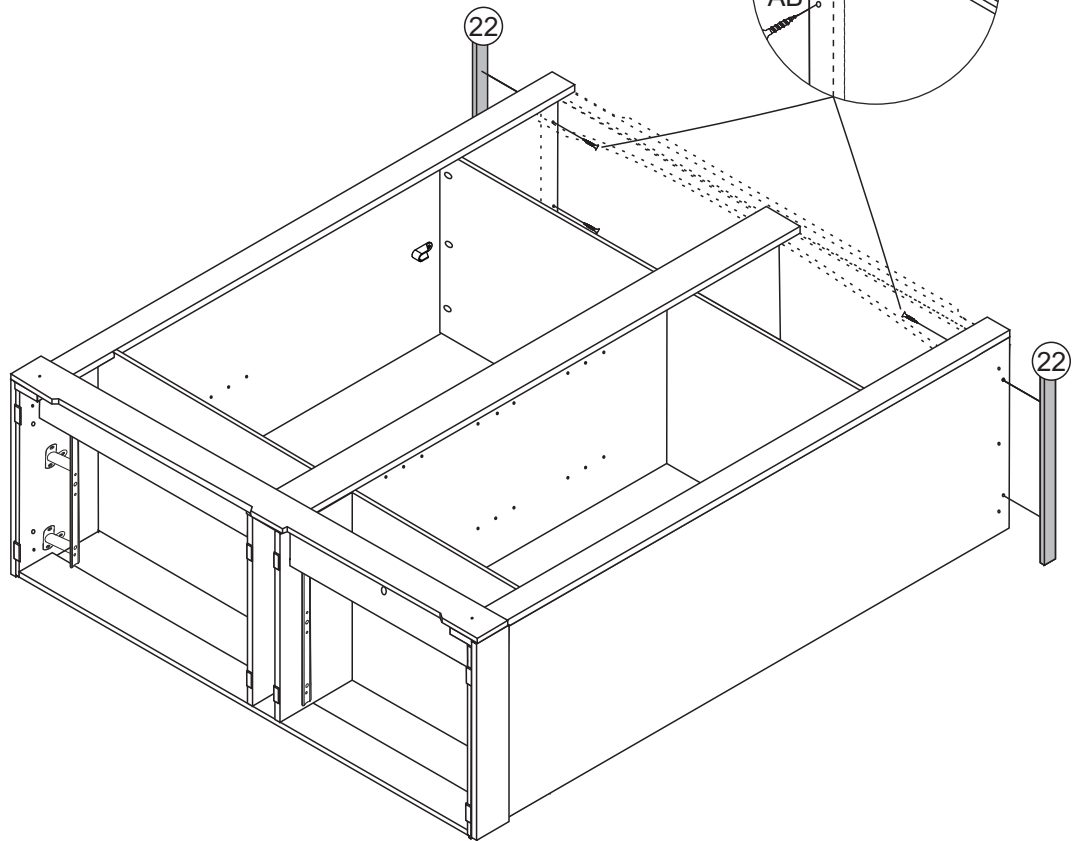

14

O- Prego
10 x 10mm
(70x)



X- Chapinha Fixação
fundo total (11x)

Atenção
Necessário girar o produto para este passo. Montagem dos fundos de acordo com a sequência do desenho, unir os fundos 1/2 no meio da divisória, e controlar o encaixe total dos fundos com os espaços entre os perfis.

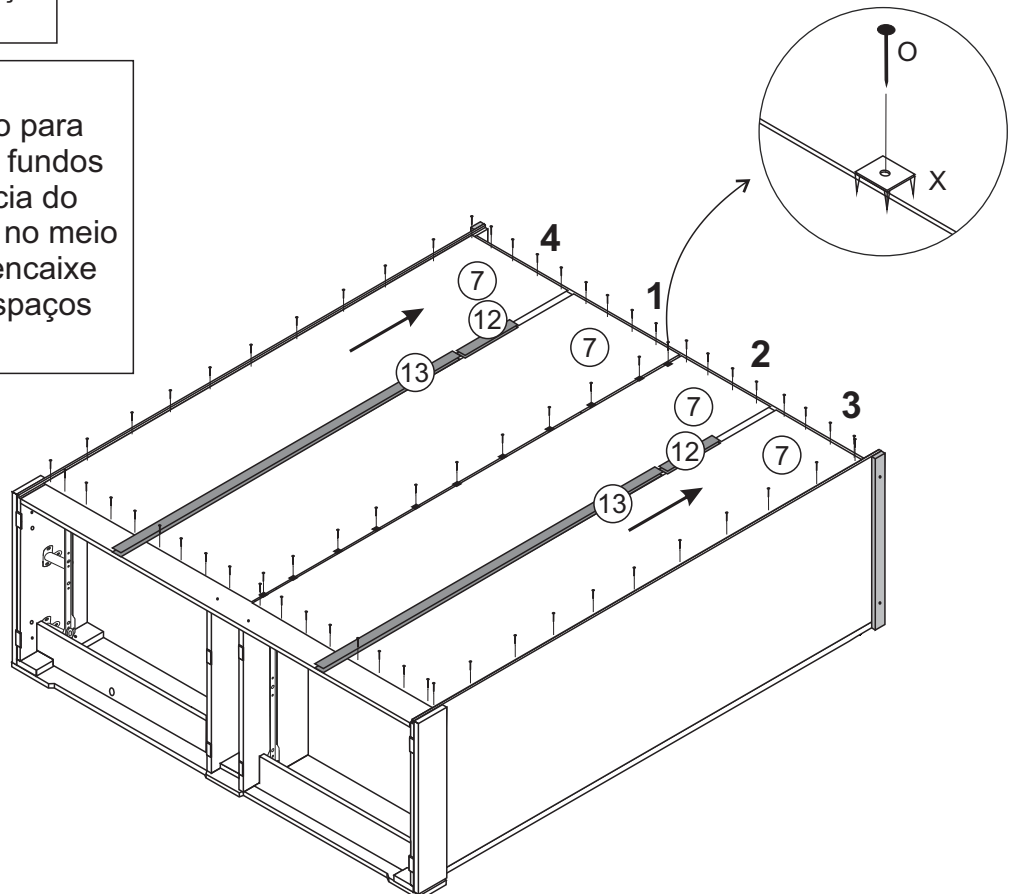

15



AB- Parafuso Flangeado
3,5 x 25 mm (3x)

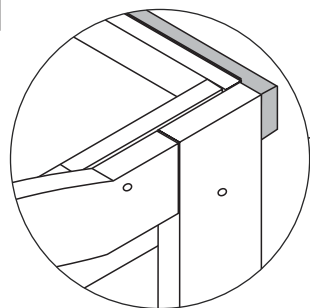

Detalhe 9

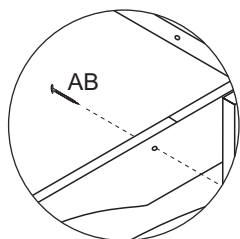
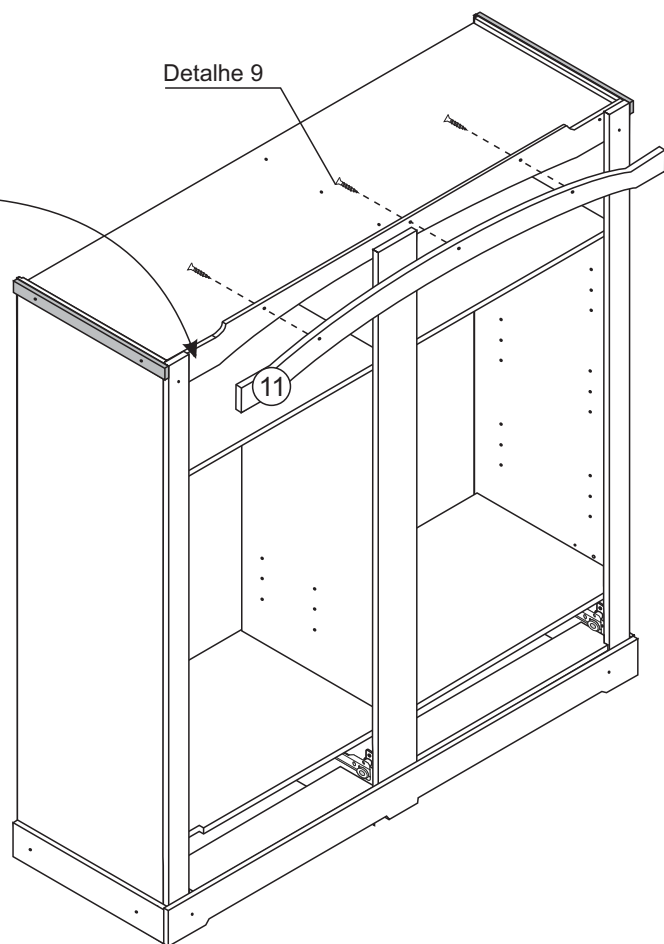

Detalhe 9

16



AB- Parafuso Flangeado
3,5 x 25 mm (4x)



U-Parafuso Chato
Ø 4 x 40mm (4x)

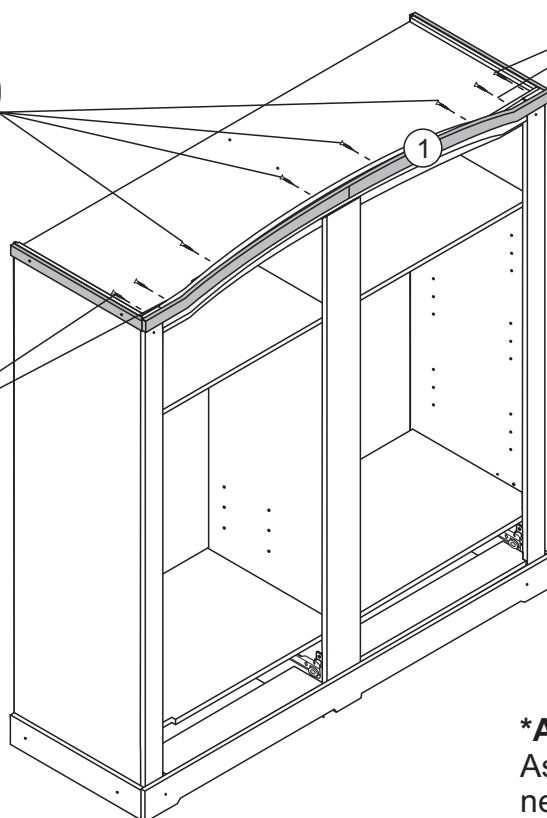
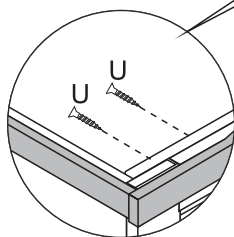
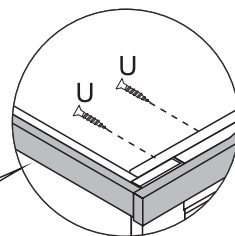
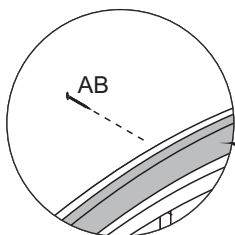

***ATENÇÃO:**

As ripas frontais são divididas,
necessário uni-las com cuidado.

17



N- Parafuso Panela
Ouro Velho Ø 3,5x14(9x)



G-Dobradiça
Ouro Velho (3x)



F- Fecho
Magnético (2x)



H- Puxador
com Parafuso (1x)



M- Parafuso Chato
Ø 3 x 12 mm(2x)

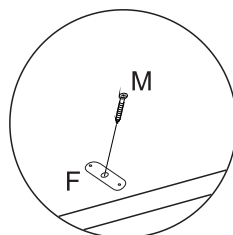
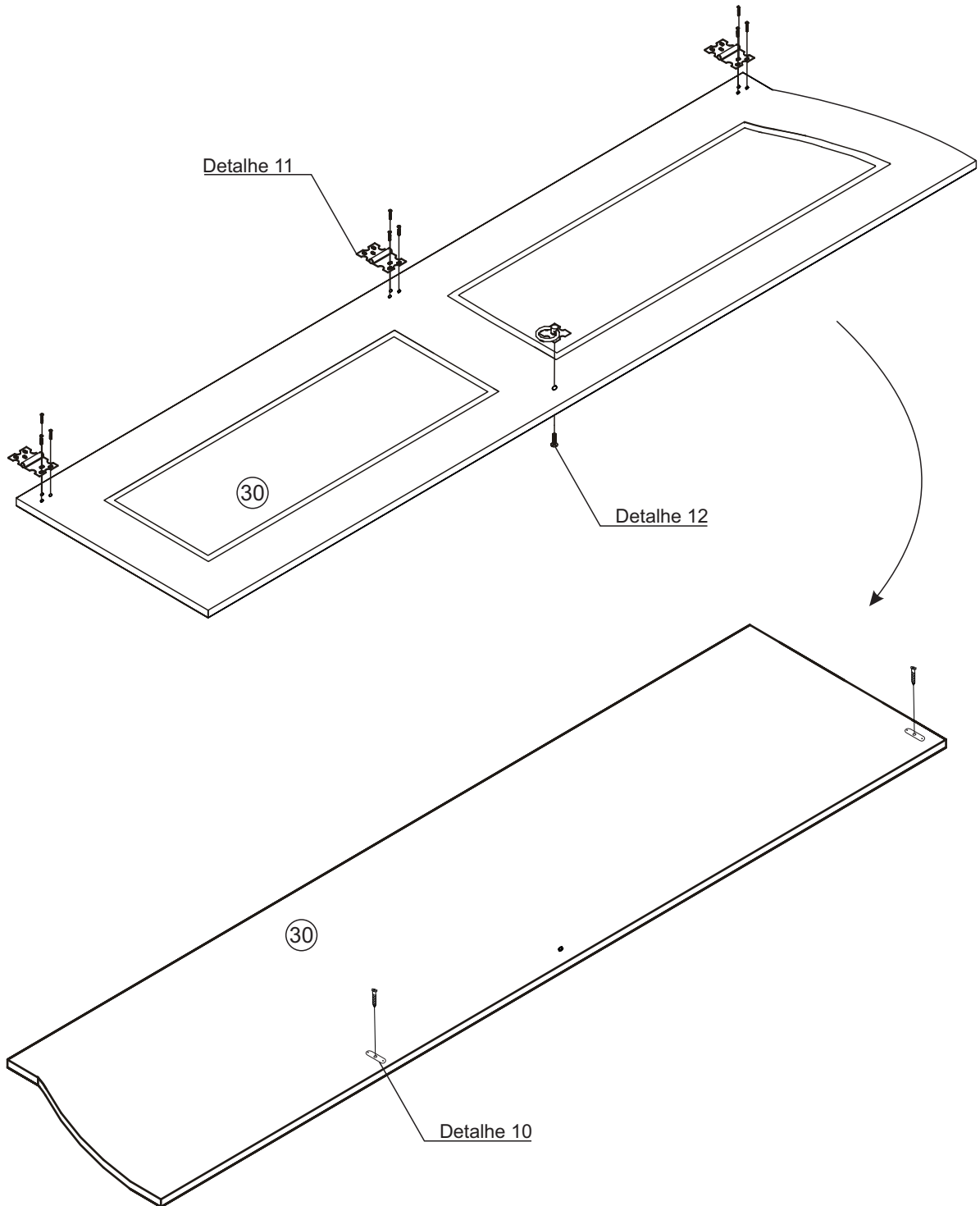



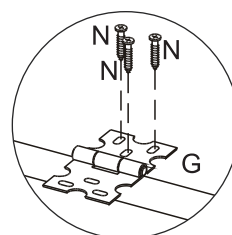

Detalhe 10

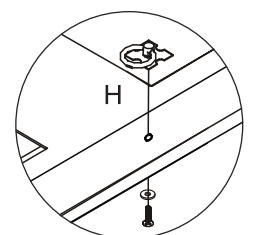

Detalhe 11



Detalhe 12

 <p>N- Parafuso Panela Ouro Velho Ø 3,5x14(9x)</p>	 <p>G-Dobradiça Ouro Velho (3x)</p>	 <p>F- Fecho Magnético (2x)</p>	 <p>H- Puxador com Parafuso (1x)</p>	 <p>M- Parafuso Chato Ø 3 x 12 mm(2x)</p>
---	--	--	--	--

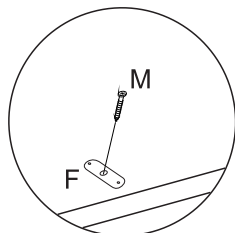
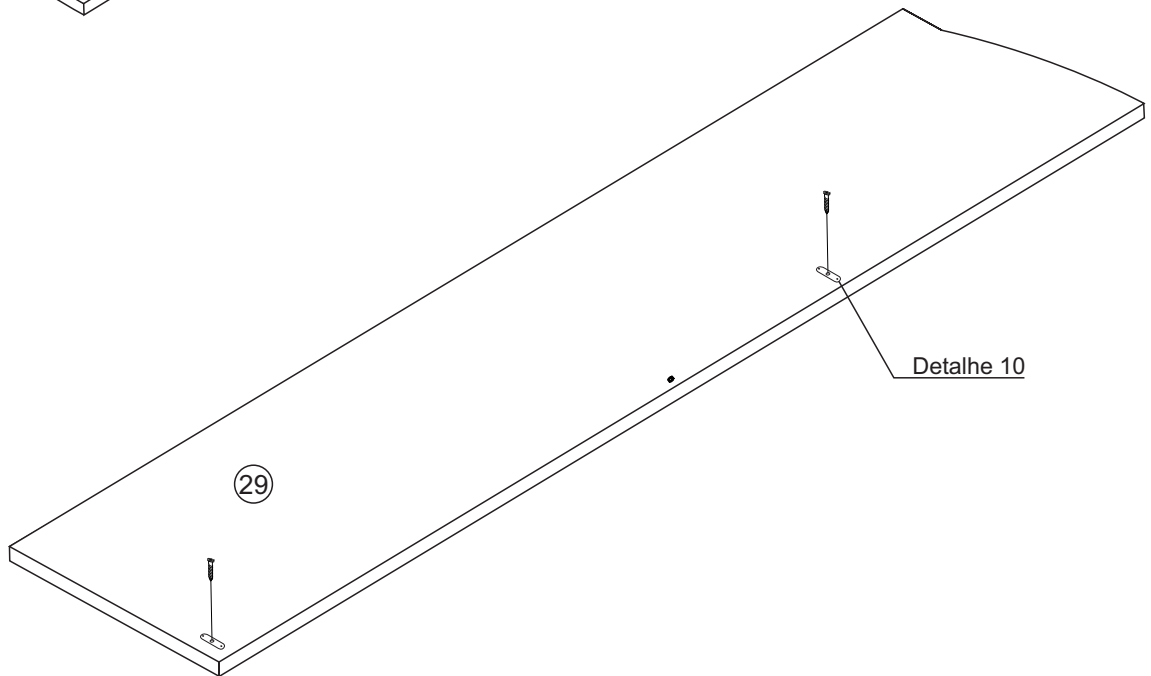
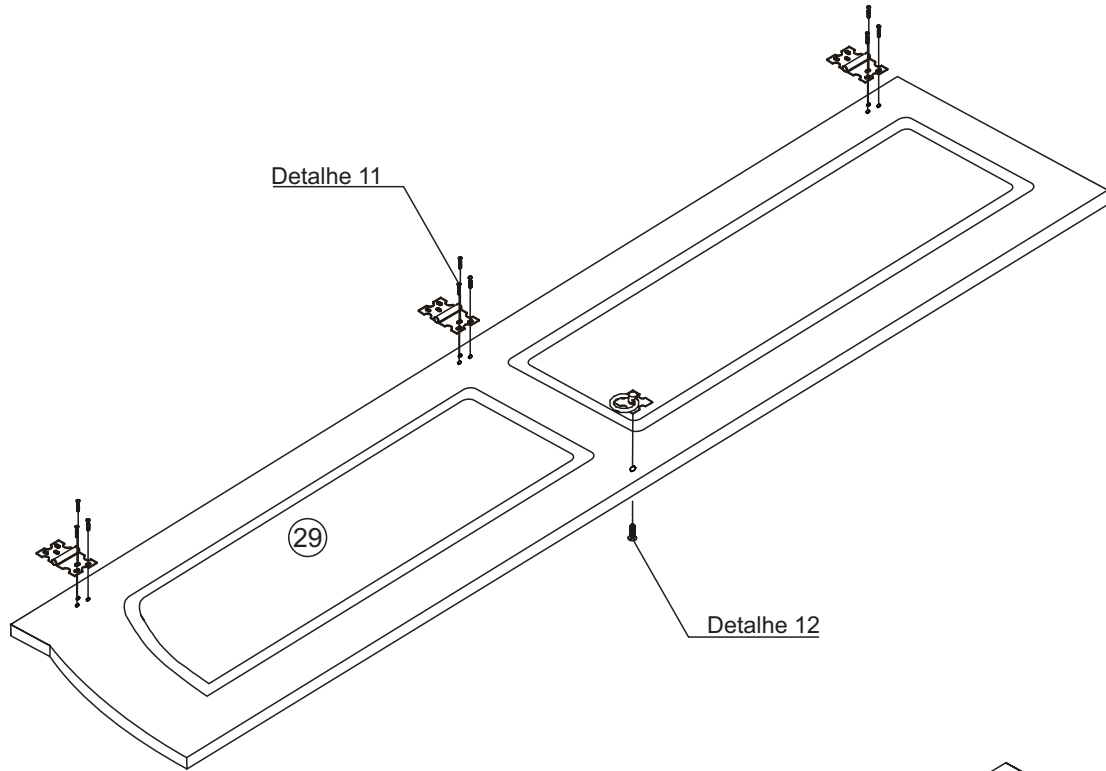

Detalhe 10

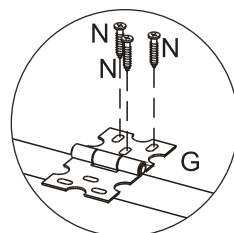

Detalhe 11

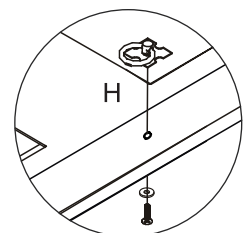

Detalhe 12

19



N- Parafuso Panela
Ouro Velho Ø 3,5x14(18x)



G-Dobradiça
Ouro Velho (6x)



F- Fecho
Magnético (4x)



H- Puxador
com Parafuso (2x)



M- Parafuso Chato
Ø 3 x 12 mm(4x)

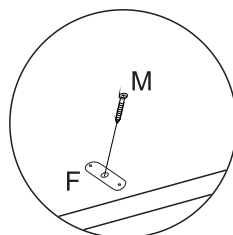
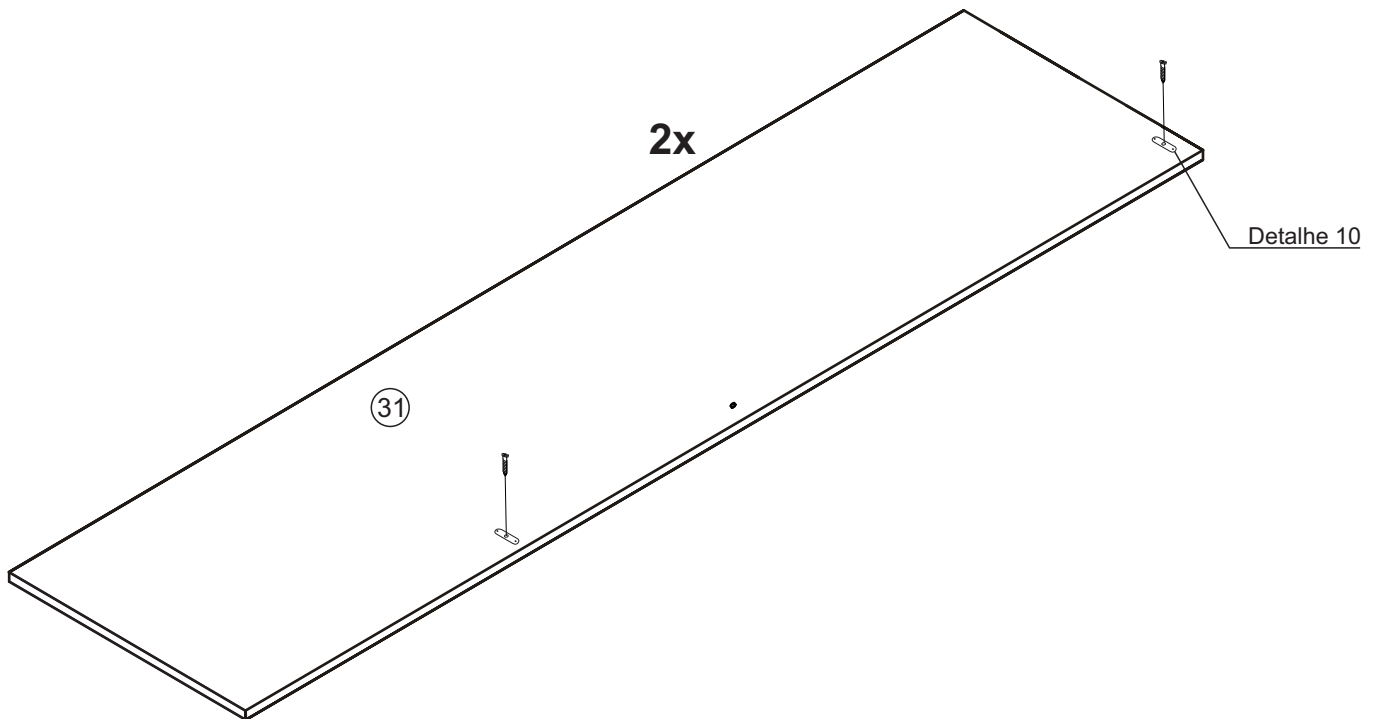
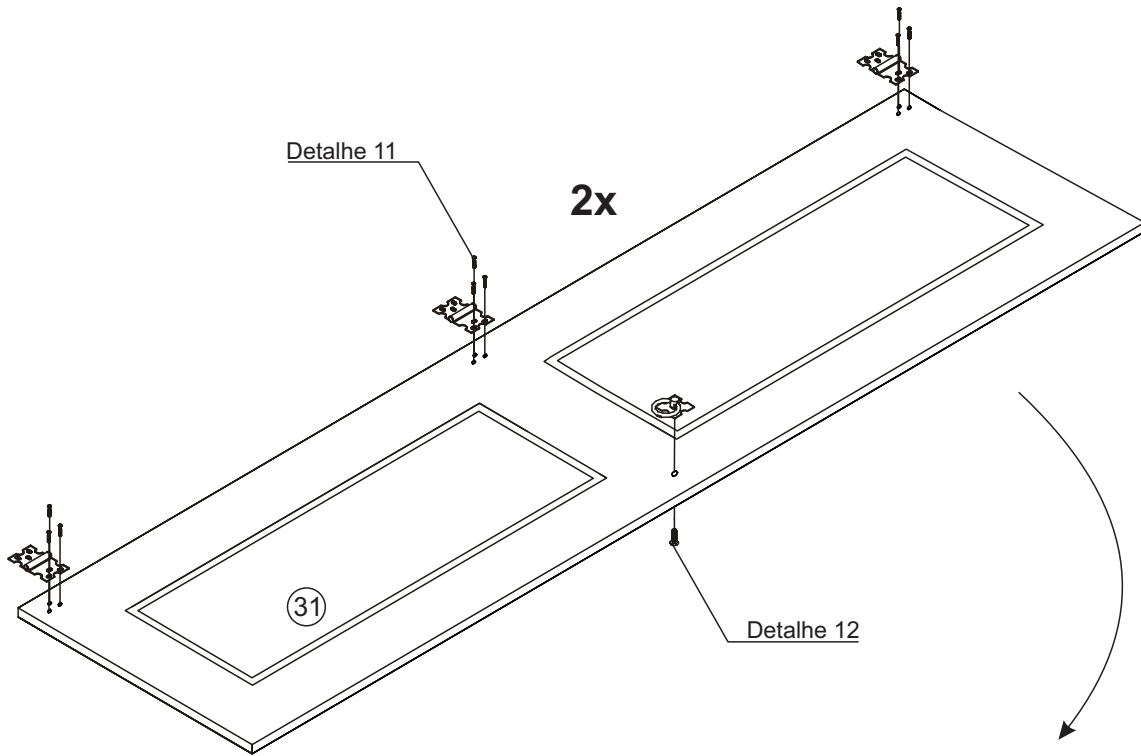

Detalhe 10

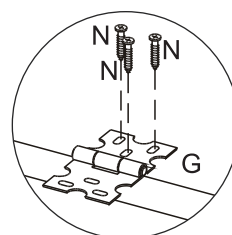



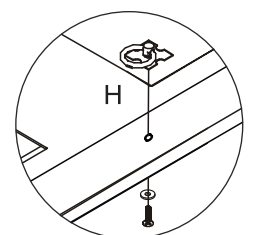





Detalhe 11



Detalhe 12

20

 <p>A- Haste Minifix (6x)</p>	 <p>C- Tapa Furo (6x)</p>	 <p>H- Puxador com Parafuso (4x)</p>	 <p>M- Parafuso Chato Ø 3 x 12 mm (12x)</p>	 <p>W- Corrediça 400mm (4x)</p>	 <p>K- Parafuso Soberbo (6x)</p>
 <p>J- Chave Allen 3mm (1x)</p>	 <p>L- Parafuso FL 3,5 x 16 mm (4x)</p>				

As gavetas com as peças (20) pintadas de vermelho na parte inferior, devem ser usadas para o lado esquerdo do roupeiro, e as com destaque azul, lado direito.

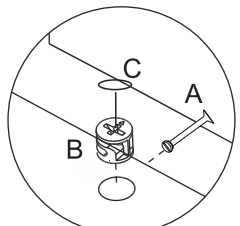
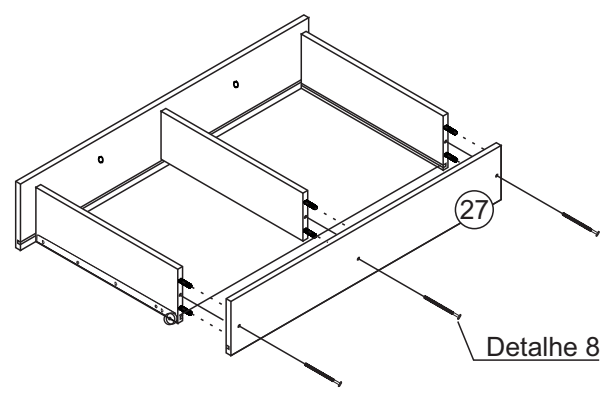
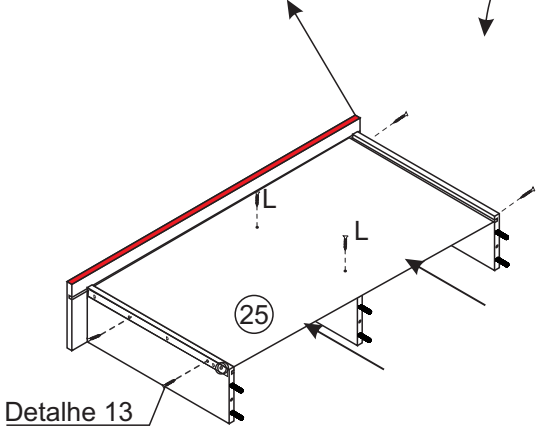
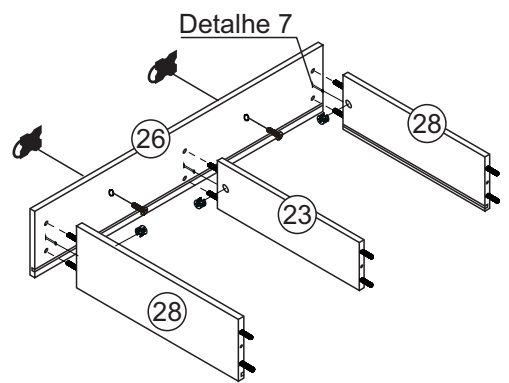

Detalhe 7

Encaixe o tambor e gire no sentido horário

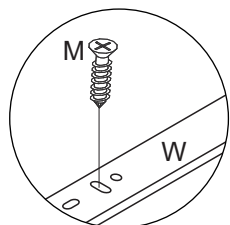

Detalhe 13

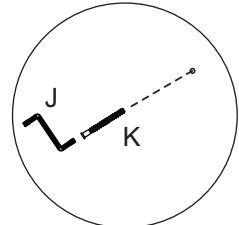

Detalhe 8

21



R- Tachão
(4x)



S- Espaçador
de Porta (2x)



N-Parafuso Panela
Ouro Velho
Ø 3,5x14(72x)

ATENÇÃO: Usar o espaçador de porta embaixo da mesma para alinhar a porta corretamente.

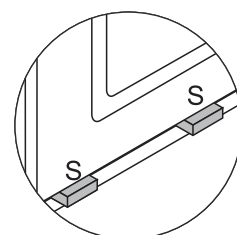
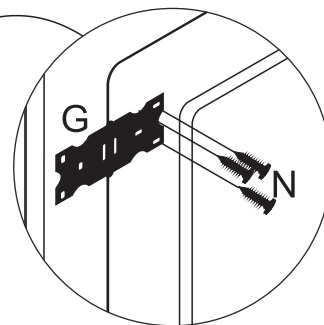
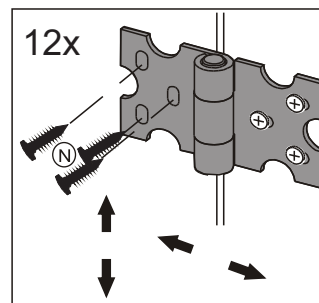
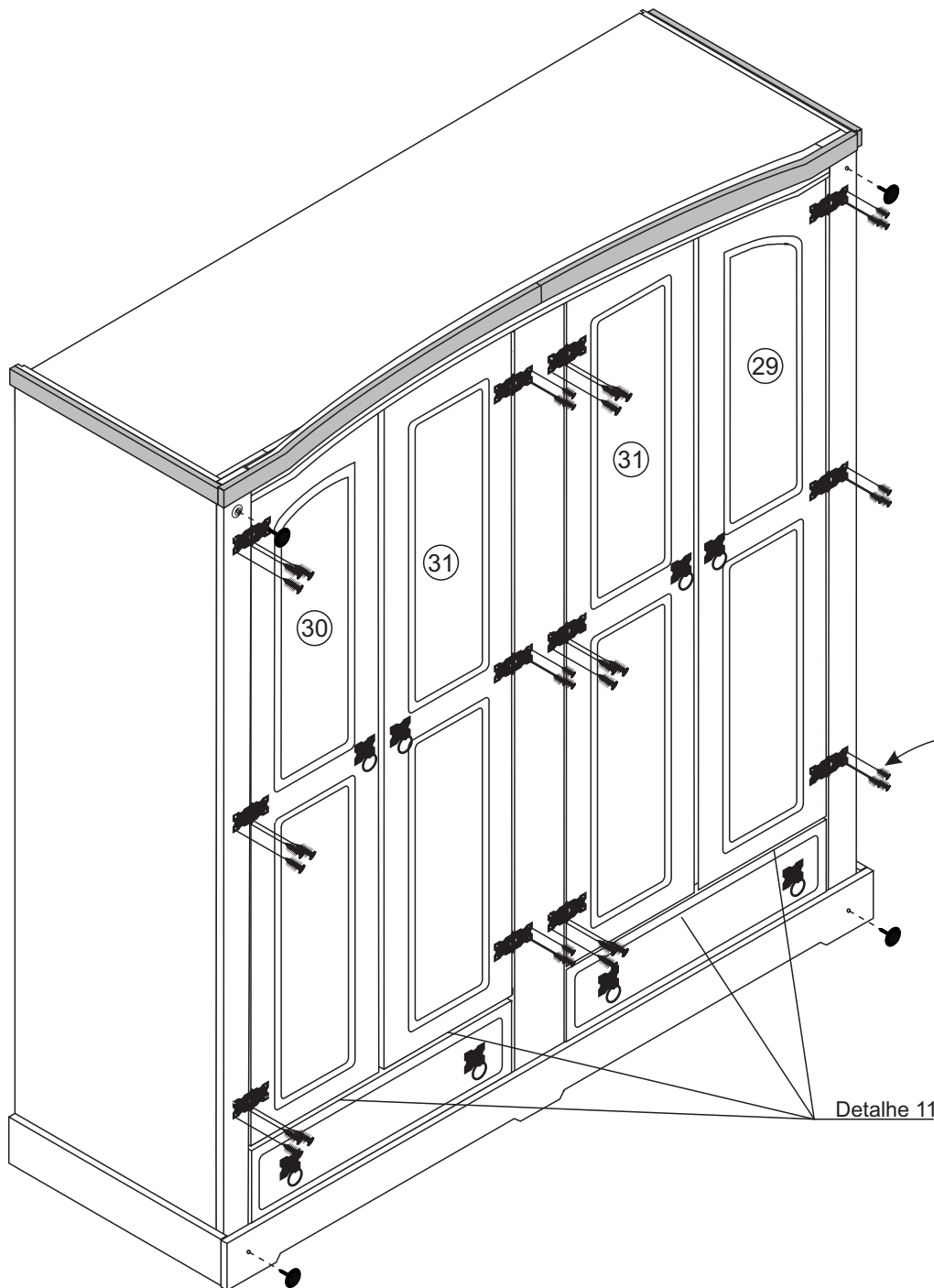

Detalhe 11

22



F- Fecho Magnético (8x)



L- Parafuso FL 3,5 x 16 mm (16x)



I- Cabideiro 898mm (1x)

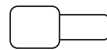

V- Suporte Prateleira cromado (16x)

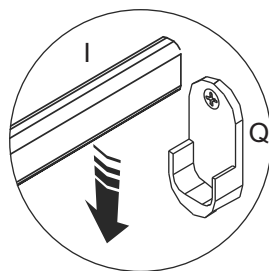
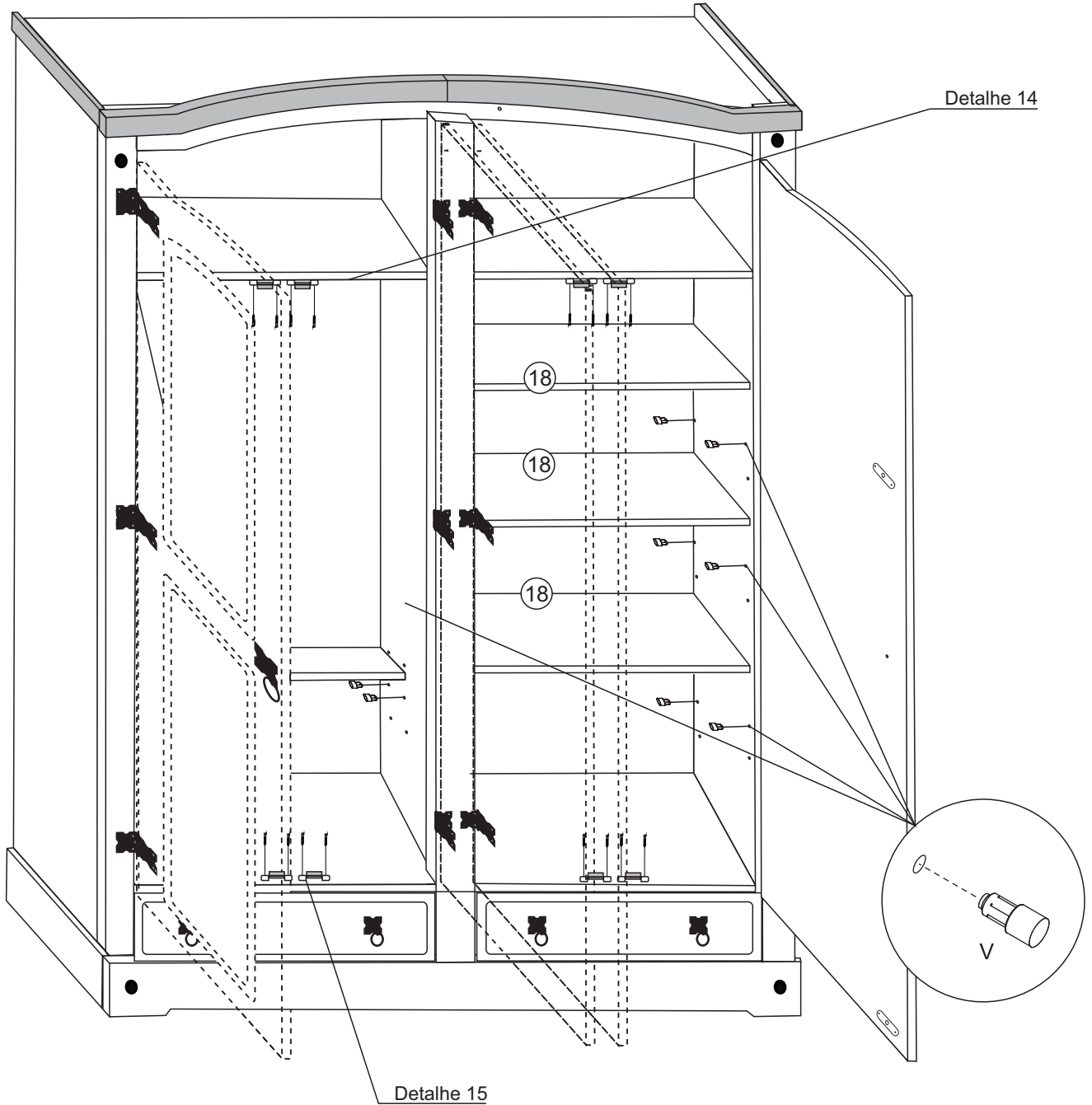

Detalhe 14

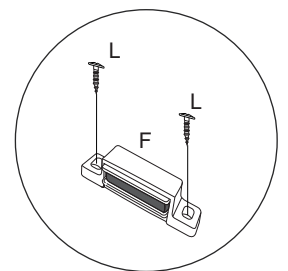

Detalhe 15