



BI CAMA CARROS DISNEY FUN - 7A
CARS TRUNDLE BED FUN - 7A
CAMA NIDO CARROS DISNEY FUN - 7A



Avenida Maracanã, 4.244 - Parque Industrial
Araçongas - PR - CEP: 86703-000
Assistência: 0800 645 2200
atendimento@puramagia.com.br
www.puramagia.com.br

INSTRUÇÕES DE MONTAGEM

Assembly Instructions

Instrucciones de Montaje

INSTRUÇÕES DE MONTAGEM VOCÊ
PODE VISUALIZAR O PASSO-A-PASSO
DE TODO O PROCESSO NO SITE
WWW.PURAMAGIA.COM.BR

YOU CAN THE ASEMBLY INSTRUCTION
ON OUR WEB SITE SETEP BY STEP:
WWW.PURAMAGIA.COM.BR

USTED PUEDE MIRAR EL PASO A PASO
DEL MONTAJE EN NUESTRO SITO:
WWW.PURAMAGIA.COM.BR

PRODUTO: **BI CAMA CARROS DISNEY FUN - 7A**

PRODUCT: **CARS TRUNDLE BED FUN - 7A**

PRODUCTO: **CAMA NIDO CARROS DISNEY FUN - 7A**



PRODUTO MONTADO / ASSEMBED PRODUCT / PRODUCTO MONTADO

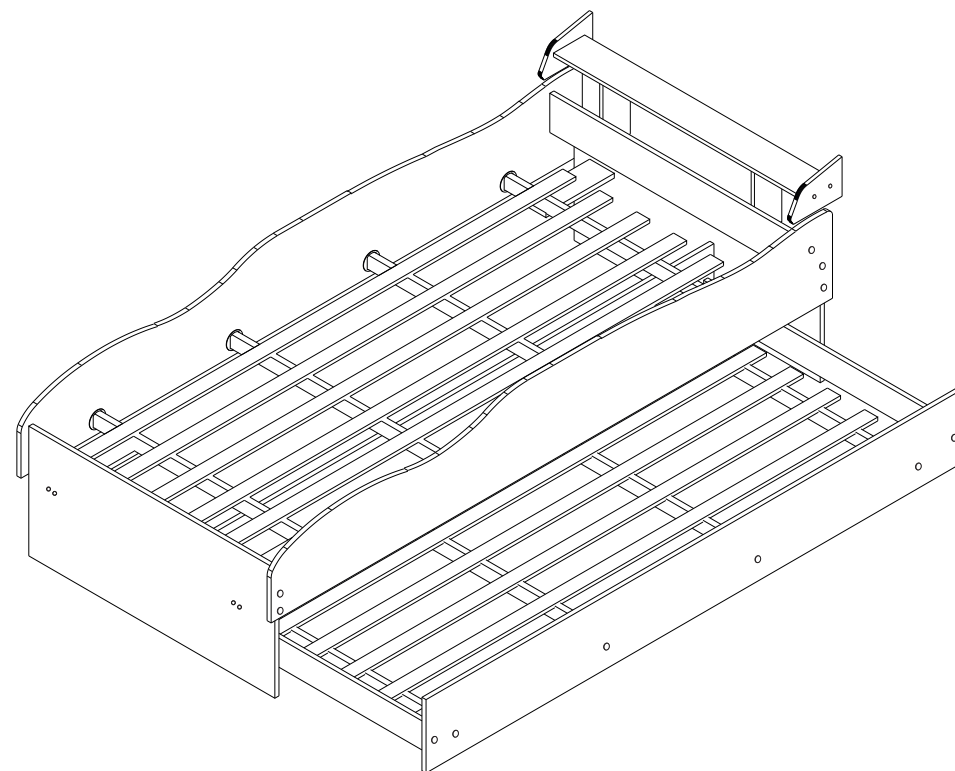

⚠ ATENÇÃO

Esta embalagem contém peças pequenas, mantenha afastada de crianças até que o produto esteja totalmente montado.
 Montagem requisitada para adultos!
 Utilizar parafusadeira com cabeça Phillips!
 As instruções são genéricas, as figuras podem variar!
 Mantenha todas as peças e componentes longe do alcance das crianças

⚠ ATTENTION

This package contains small parts, keep away from children until the product is fully assembled.
 Must be assembled by an adult!
 Use screwdriver with Phillips head.
 The instructions are generic, the figures may vary.

⚠ ATENCIÓN

Esa embalaje contiene piezas pequeñas, mantenga lejos de los chicos hasta el producto estea totalmente armado.
 Montaje debe ser hecha por adultos!
 Utilizar parafusadeira com cabeça Phillips!
 Las instrucciones son genericas, los dibujos pueden variar.



MONTAGEM DO PRODUTO / PRODUCT ASSEMBLY / MONTAJE DEL PRODUCTO

5º PASSO / STEP / PASO

Fixe os rodízios 'M' nas travessas N°08, utilizando parafusos 3,5 x 12 CC Phillips 'F'.

Fix the wheels 'M' on the piece N°08, using 'F'.

Fije las ruedas 'M' en la pieza N°08 utilizando 'F'.

M	04 und.
	Rodizio Wheels Ruedas
F	08 und.
	Parafuso 3,5 x 12 CC Screw 3,5 x 12 CC Tornillo 3,5 x 12 CC

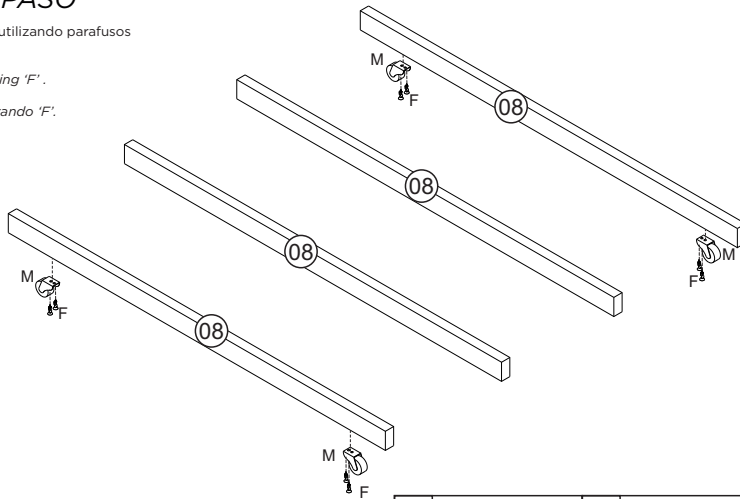

6º PASSO / STEP / PASO

Prepare a peça N°14 com Cavilha 'A' e Porca Cilíndrica 'F'. Fixe a peça N°12 com a N°14 utilizando parafusos 5,0x 50 CC Phillips 'B', e com a peça N°08 utilizar parafusos 4,0 x 40 CC Phillips 'C' e suporte plástico 'S'.

Repita o mesmo procedimento com a peça N°13.

Fixe as longarinas N°06 utilizando pregos ardox 12 x 12 'L'.

Após cole as tampas adesivas 12mm 'P' nos parafusos.

Prepare the pieces N°14 using 'A' and 'F'.

Fix the piece N°12 on the N°14 using 'B', for the piece N°08 use 'C' and 'S'.

Repeat the same with the piece N°13.

Fix the stringers N°06 with nails 12 x 12 'L'.

After fixing, put 'P' upon the screws.







Preparare las piezas N°14 con 'A' y 'F'.

Fije la pieza N°12 con la N°14 utilizando 'B' y con la pieza N°08 use 'C' y 'S'.

Repetir el mismo procedimiento con la pieza N°13.

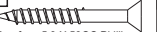
Fije las zancas N°06 con 'L'.

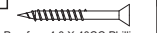
Después de la fijación pegue 'P'.

A	04 und.	I	04 und.
	Cavilha 6 x 30 Dowel 6 x 30 Clavija 6 x 30		Porca Cilíndrica 12 x 09 Nut 12 x 09 Tuerca 12 x 09
B	04 und.	L	24 und.
	Parafuso 5,0 X 50CC Phillips Screw 5,0 X 50CC Phillips Tornillo 5,0 X 50CC Phillips		Prego Ardox 12 x 12 Nail Ardox 12 x 12 Clavo Ardox 12 x 12
C	08 und.	S	08 und.
	Parafuso 4,0 X 40CC Phillips Screw 4,0 X 40CC Phillips Tornillo 4,0 X 40CC Phillips		Suporte Plástico para estrado. Plastic Support Soporte Plastico

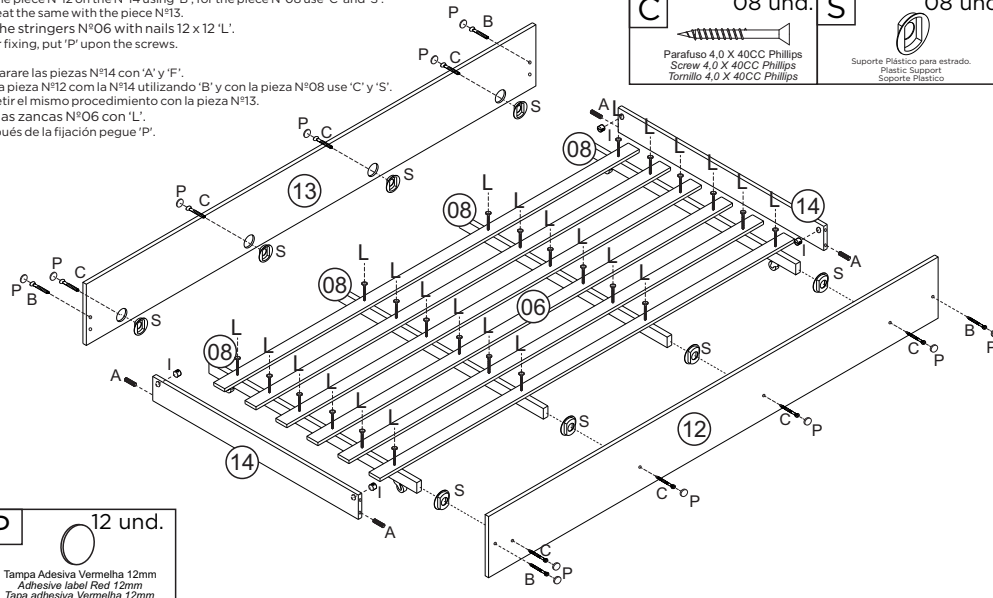

P	12 und.
	Tampa Adesiva Vermelha 12mm Adhesive label Red 12mm Tapa adhesiva Vermelha 12mm

PESO SUPORTADO / DIMENSÕES DO PRODUTO MONTADO SUPPORTED WEIGHT / DIMENSIONS ASSEMBLED PRODUCT PESO SOPORTADO / DIMENSIONES PRODUCTO ARMADO

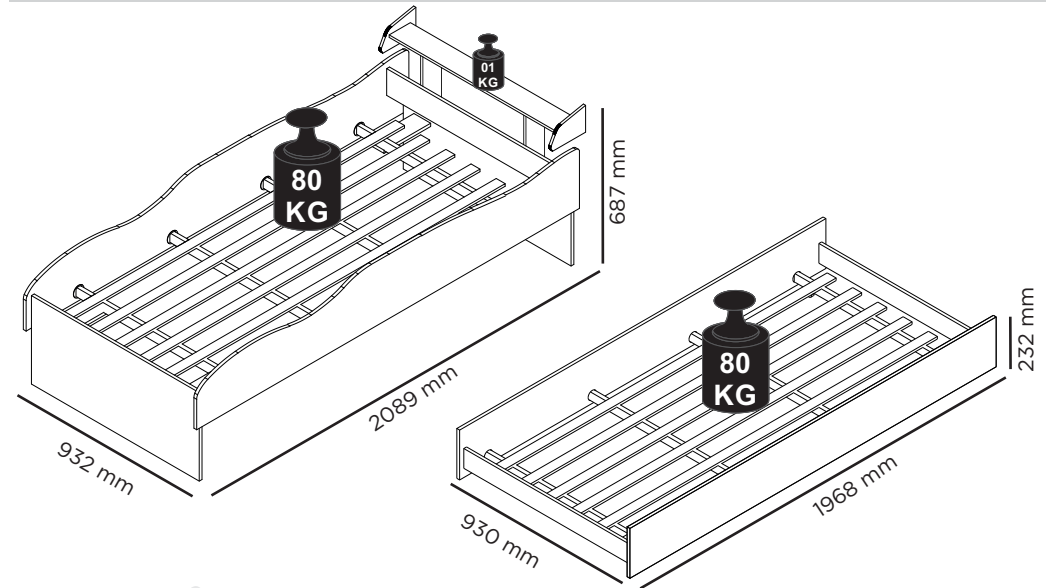

JÁ QUE VOCÊ VIROU
UM ENGENHEIRO VEJA
AS FERRAMENTAS QUE
IRÁ PRECISAR!

YOU ARE AN
ENGINEER NOW,
CHECK THE TOOLS
YOU'LL NEED!

MIRA LAS
HERRAMIENTAS QUE
VA A UTILIZAR EN EL
MONTAJE!

DICAS IMPORTANTES

1. Leia atentamente todas as instruções antes de iniciar a montagem.
2. Separe e guarde a etiqueta de identificação.
3. Confira se os volumes e quantidades de peças descritos no manual estão corretos.
4. Identifique as peças e separe os acessórios.
5. A montagem do produto deverá ser feita em uma superfície limpa e plana. Aconselhamos utilizar a própria embalagem para forrar o chão afim de não danificar o produto.
6. Reserve área livre para montagem do produto.
7. Evite batidas e o contato com objetos cortantes.

Limpeza e Conservação

1. Não expor o móvel a calor excessivo (luz solar direta), ou umidade elevada.
2. Para limpeza use um pano macio seco ou ligeiramente umedecido com água. Não use agentes de limpeza ou abrasivos.

FERRAMENTAS NECESSÁRIAS TOOLS REQUIRED / HERRAMIENTAS NECESARIAS

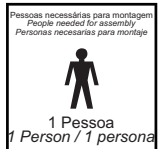
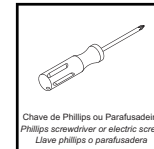
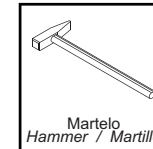

IMPORTANT TIPS

1. Read all instructions before beginning assembly
2. Separate and store the identification label.
3. Confirm the volumes and quantities of parts described in the manual.
4. Identify and separate the parts and accessories.
5. The assembly of the product should be done on a clean and flat surface. We recommend using the package itself to cover the floor to prevent product damage.
6. Reserve free area for product assembly.
7. Avoid impacts and contact with sharp objects.

Cleaning and Conservation

1. Do not expose the product to excessive heat (direct sunlight) or high humidity.
2. For cleaning use a dry or slightly moistened soft cloth with water. Do not use cleaning agents or abrasives.

DICAS IMPORTANTES

1. Leer atentamente todas las instrucciones antes de empezar el montaje
2. Separe y guarde las etiquetas de identificación
3. Mire si los volúmenes y cantidades de piezas descritos en manual están correctos
4. Identifique las piezas y separe los accesorios.
5. El montaje del producto debe realizarse sobre una superficie limpia y plana. Le recomendamos que utilice la propia embalaje para cubrir el suelo para evitar daños en el producto.
6. Dejar una área libre para armar el producto
7. Evite impactos y contacto con objetos cortantes

Limpeza y Conservación

1. No dejar el producto en locales muy calientes (luz del sol directa) o demasiada umidade
2. Para la limpieza utilizar un paño suave y seco o ligeramente humedecido con agua. No utilice productos abrasivos.

IDENTIFICAÇÃO DAS PEÇAS

IDENTIFICATION OF PARTS / IDENTIFICACIÓN DE LAS PIEZAS

CÓDIGO	INFORMAÇÃO DAS PEÇAS	IDENTIFICATION OF PARTS	IDENTIFICACIÓN DE LAS PIEZAS	CÓD. PROD			MEDIDAS (mm)			MAT.
				PROD	COR	QTD	COMP	LARG	ESPE	
01	Lateral Direita	Right side	Lateral derecha	---	---	01	2,053	0,299	0,015	MDP
02	Lateral Esquerda	Left side	Lateral izquierda	---	---	01	2,053	0,299	0,015	MDP
03	Peseira	Footboard	Piecero	---	---	01	0,900	0,410	0,015	MDP
04	Cabeceira (Superior)	Headboard (Top)	Cabecera (Superior)	---	---	01	0,900	0,124	0,015	MDP
05	Cabeceira (Inferior)	Headboard (Bottom)	Cabecera (Inferior)	---	---	01	0,900	0,357	0,015	MDP
06	Longarina	Stringer	Zanca	---	---	12	1,815	0,048	0,012	MDF
08	Travessa do Estrado	Bed Slats Support	Travesa del estrado	---	---	08	0,910	0,045	0,020	MADEIRA
09	Prateleira	Shelf	Repisa	---	---	01	0,900	0,114	0,012	MDF
10	Suporte	Holder	Soporte	---	---	02	0,205	0,100	0,012	MDF
11	Laterais Aerofolio	Airfoil Sides	Lateral del Airelon	---	---	02	0,190	0,125	0,012	MDF
12	Lateral Direita Cama AUX	Auxiliary Bed Right Side	Lateral derecha Cama Supletório	---	---	01	1,968	0,232	0,015	MDP
13	Lateral Esquerda Cama AUX	Auxiliary Bed Left Side	Lateral izquierda Cama Supletório	---	---	01	1,968	0,232	0,015	MDP
14	Cabeceira/Peseira AUX	Auxiliary Headboard/Footboard	Cabecera/Piecero Cama Supletório	---	---	02	0,900	0,092	0,015	MDP
15	Trava Auxiliar	Auxiliary Suport	Latch Auxiliary	---	---	04	0,250	0,083	0,015	MDP

ASSISTÊNCIA TÉCNICA

Ao solicitar assistência técnica, informe o número da peça, nome e cor do produto e a data de fabricação do lote que se encontra carimbado na peça nº06.

TECHNICAL ASSISTANCE

When request the technical assistance, inform the number of the piece name and color of the product and also the batch manufacturing date, that is stamped on the piece nº06.

ASISTENCIA TÉCNICA

Al solicitar la asistencia técnica, informe el número de la pieza, el nombre y el color del producto y también la fecha de fabricación del lote, que se estampa en la pieza nº06.

No Site
www.puramagia.com.br
TEM MAIS DICAS

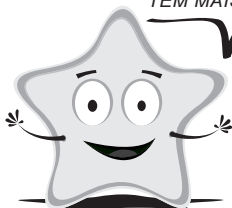

MONTAGEM DO PRODUTO / PRODUCT ASSEMBLY / MONTAJE DEL PRODUCTO

4º PASSO / STEP / PASO

Prepare a Prateleira Nº09, utilizando porcas cilíndricas 12 x 09 'I'.
Fixe as haste simples minifix 'G' na peça Nº09.
Prepare o Suporte Nº10 utilizando cavilhas 6 x 30 'A' e tambor minifix 12 mm 'H'.
Fixe as Laterais do Aerofólio Nº11 na prateleira Nº09 utilizando parafusos 4,0 X 40 CC Phillips 'C'.
Encaixe a peça Nº09 com a peça Nº10 e aperte o tambor minifix 'H'.
Centralize o Aerofólio na parte superior da cabeceira da cama.
Faça a fixação do Aerofólio utilizando Dispositivos Trapézio 'K' na peça Nº 10 e Parafuso 4,0 x 25 CP 'E', fixando na cabeceira Nº05.
Finalize colando as tampas adesivas 'O' e 'R'.

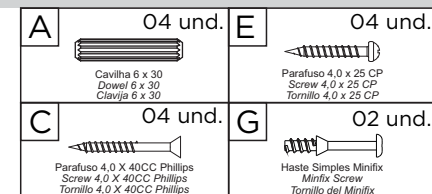

Prepare Nº09 with 'I'.
Fix 'G' on the piece Nº09.
Prepare Nº10 using 'A' and 'H'.
Fix the pieces Nº11 on the piece Nº09 using 'C'.
Put the pieces Nº10 on the piece Nº09 and fix 'H'.
Centralize the airfoil on the top of the headboard.
Fix it using 'K' on the piece Nº09 and 'E', fixing the part Nº04.
Put 'O' and 'R' to finish it.

Preparare Nº09 utilizando 'I'.
Fije 'G' en la pieza Nº09.
Prepare la pieza Nº10 utilizando la 'A' y 'H'.
Fije la pieza Nº11 en la pieza Nº09 utilizando 'C'.
Coloque la pieza Nº10 en la pieza Nº09 y fije el 'H'.
Centralice el aerofolio en la parte superior de la cabecera.
Fijarlo con 'K' en la pieza Nº10 y 'E', fijar en la parte Nº04.
Aplique 'O' y 'R'.

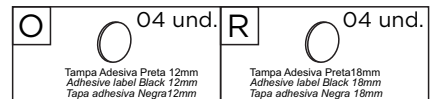
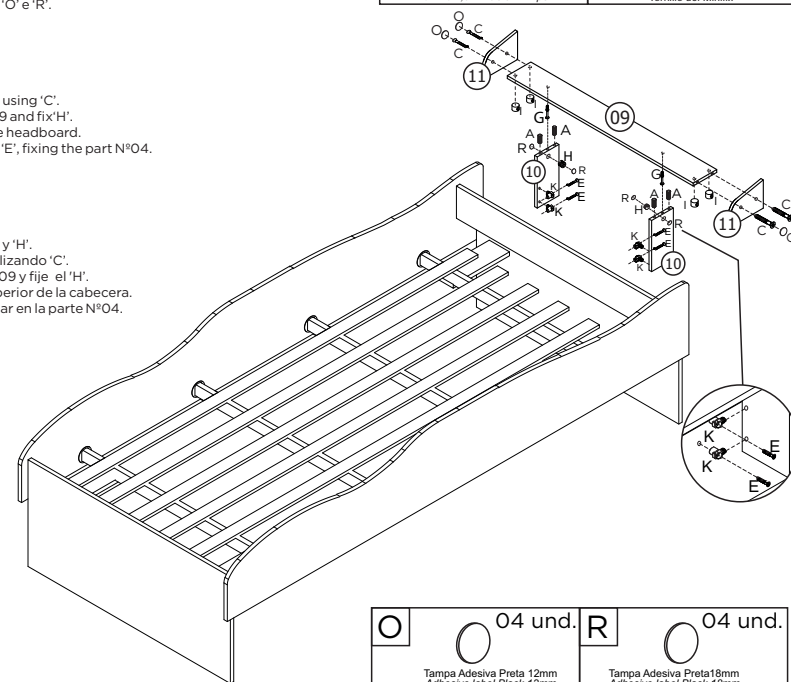
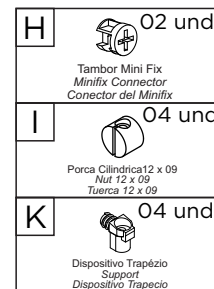

VISTA AEROFOLIO MONTADO AIRFOIL ASSEMBLED VIEW VISTA PERFIL AERODINÂMICO ARMADO

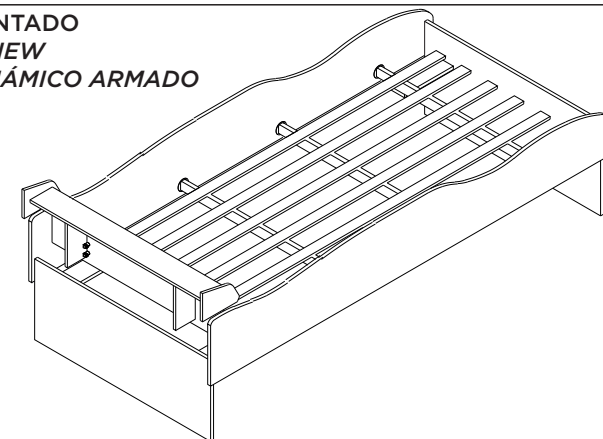

MONTAGEM DO PRODUTO / PRODUCT ASSEMBLY / MONTAJE DEL PRODUCTO

2º PASSO / STEP / PASO

Prepare a peça N°15 com porca cilíndrica 'I'.

Fixe a lateral esquerda N°02 na peseira N°03 e cabeceira N°04 utilizando parafusos 5,0 x 50 CC Phillips 'B'.

Fixe a lateral esquerda N°02 na peseira N°03 e cabeceira N°04 utilizando parafusos 5,0 x 50 CC Phillips 'B'.

Coloque as travessas do estrado N°08 nas laterais N°01 e 02 e fixe-as utilizando suporte plástico 'S' e parafusos 4,0 x 40 CC Phillips 'C'.

Fixe a cantoneira 3 furos 'J' na peça N°03 e 05 com a N°01 e 02, utilizando parafusos 3,5 x 12 CC Phillips 'F'.

após fixação cole as tampas adesivas 12mm 'P'.

Prepare the pieces N°15 using 'I'.

Fix the N°15 on the N°03 and 05 using 'B'.

Put the lone support N°08 on the sides and fix them using 'C' and 'S'.

Fix the side N°02 on the N°03 and 04 using 'B'.

Fix 'J' on the piece N°03 and 05 with the piece N°01 and 02 using 'F'.

After fixing, put the 'P' upon the screws.

Preparare las piezas N°15 utilizando 'I'.





Fije la pieza N°15 en las N°03 y 05 utilizando 'B'.

Ponga las travessas del estrado N°08 en los lados y las fije utilizando 'C' y 'S'.

Fije la lateral N°02 en las piezas N°03 y N°04 utilizando 'B'.

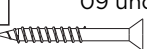
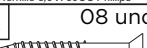
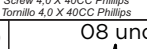
Fije 'J' en la pieza N°03 y 05 las N°01 y 02 utilizando 'F'.

Después de la fijación aplique 'P'.

B	09 und.
	Parafuso 5,0 X 50CC Phillips Screw 5,0 X 50CC Phillips Tornillo 5,0 X 50CC Phillips
C	08 und.
	Parafuso 4,0 X 40CC Phillips Screw 4,0 X 40CC Phillips Tornillo 4,0 X 40CC Phillips
D	08 und.
	Parafuso 4,0 X 30 Frangeado Screw 4,0 X 30 Frangeado Tornillo 4,0 X 30 Frangeado
I	04 und.
	Porca Cilíndrica 12 x 09 Nut 12 x 09 Tuerca 12 x 09
P	07 und.
	Tampa Adesiva Vermelha 12mm Adhesive label Red 12mm Tapa adhesiva Vermelha 12mm
S	08 und.
	Suporte Plástico para estrado. Plastic Support Soporte Plástico

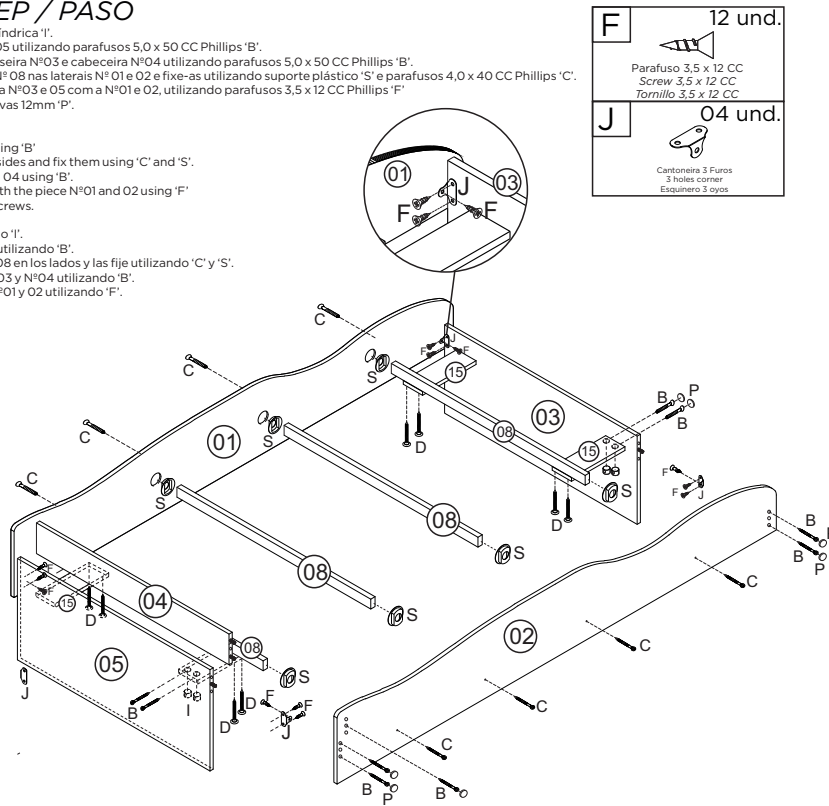

3º PASSO / STEP / PASO

Fixe as longarinas N°06 utilizando pregos ardox 12 x 12 'L'.

Cole a etiqueta Pura Magia 'Q' na peça N°03.



Fix the stringers N°06 with nails 12 x 12 'L'.

Paste 'Q' on the piece N°03.

Fije las the zancas N°06 con clavos 12 x 12 'L'.

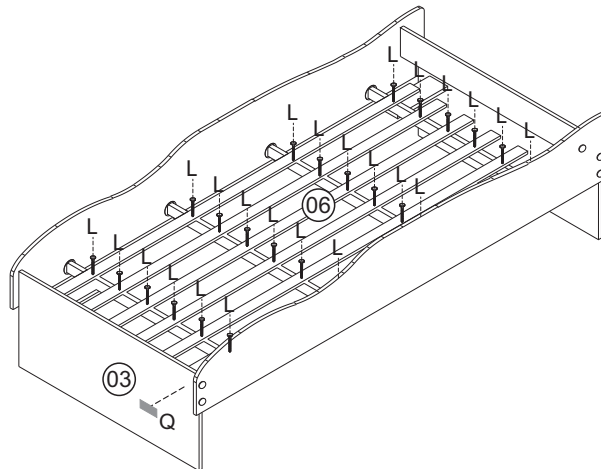
Pegue 'Q' en la pieza N°03.







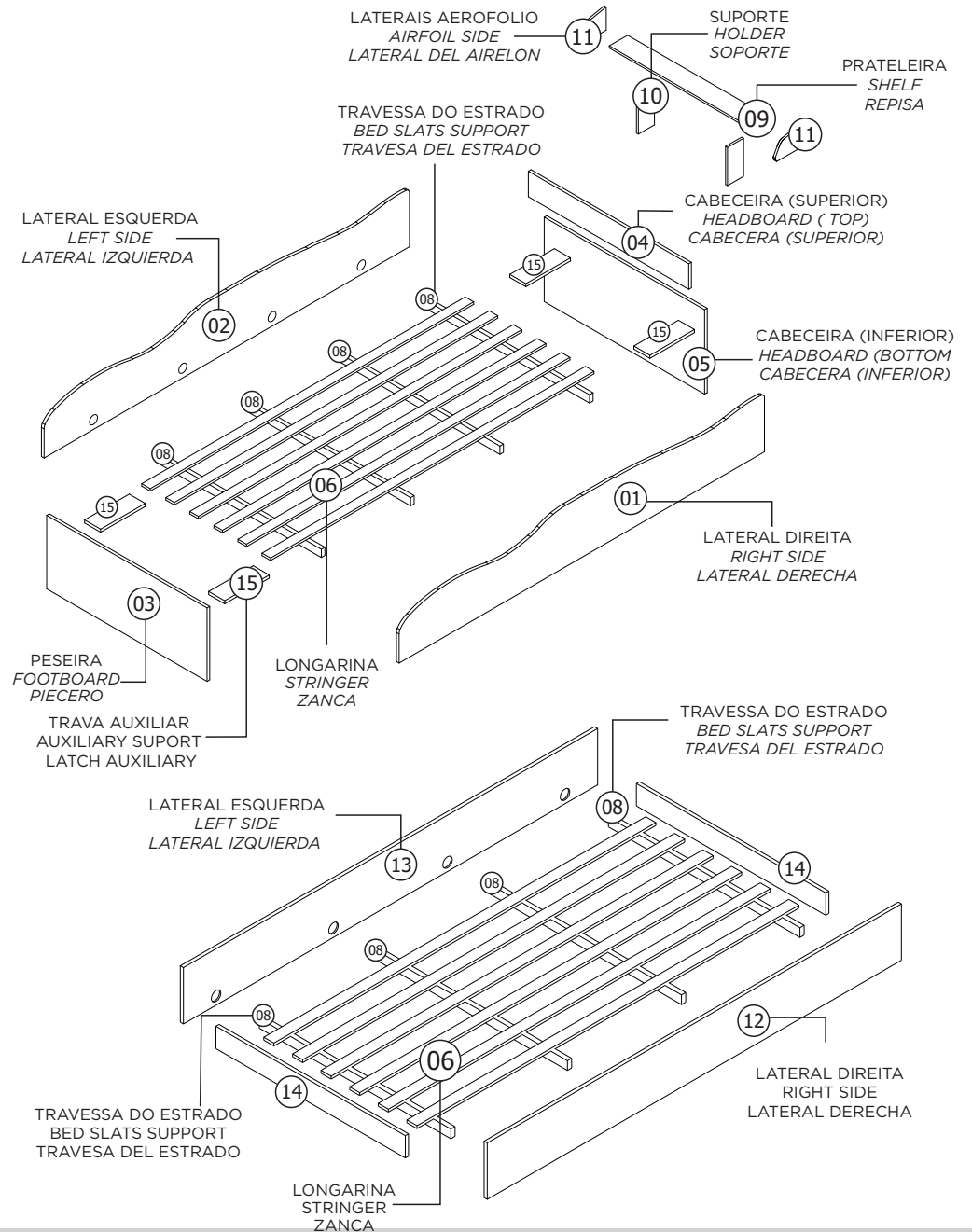



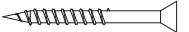

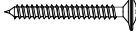
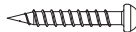

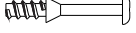



L	24 und.
	Prego Ardox 12 x 12 Nail Ardox 12 x 12 Clavo Ardox 12 x 12
Q	01 und.
	Etiqueta Pura Magia Pura Magia label

IDENTIFICAÇÃO DAS PEÇAS / IDENTIFICACIÓN DE LAS PIEZAS



FERRAGENS / IRONMONGERY / HERRAJES

A 16 und.  Cavilha 6 x 30 Dowel 6 x 30 Clavija 6 x 30	B 22 und.  Parafuso 5,0 x 50 CC Screw 5,0 x 50 CC Tornillo 5,0 x 50 CC	C 20 und.  Parafuso 4,0 x 40 CC Screw 4,0 x 40 CC Tornillo 4,0 x 40 CC	D 08 und.  Parafuso 4,0 x 30 Franjeado Screw 4,0 x 30 Franjeado Tornillo 4,0 x 30 Franjeado	E 04 und.  Parafuso 4,0 x 25 CP Screw 4,0 x 25 CP Tornillo 4,0 x 25 CP
F 20 und.  Parafuso 3,5 x 12 CC Screw 3,5 x 12 CC Tornillo 3,5 x 12 CC	G 02 und.  Haste Simples Minifix Minifix Screw Tornillo del Minifix	H 02 und.  Tambor Mini Fix Minifix Connector Conector del Minifix	I 26 und.  Porca Cilíndrica Plástica 12x09 Plastic Nuts 12x09 Tuerca Cilíndrica Plástica 12x09	J 04 und.  Cantoneira 3 Furos 3 holes corner Esquinero 3 oyo
K 04 und.  Dispositivo Trapézio Support Dispositivo Trapecio	L 52 und.  Prego Ardox 12 x 12 Nail Ardox 12 x 12 Clavo Ardox 12 x 12	M 04 und.  Rodízio Wheels Ruedas	N 04 und.  Sapata Lateral Side shoes Zapata lateral	O 04 und.  Tampa Adesiva 12mm Preta Adhesive Label 12mm Black Tapa Adhesiva 12mm Preta
P 26 und.  Tampa Adesiva 12mm Vermelha Adhesive Label 12mm Red Tapa Adhesiva 12mm Vermelha	Q 01 und.  Etiqueta Pura Magia Pura Magia Label Etiqueta Pura Magia	R 04 und.  Tampa Adesiva 18mm Preta Adhesive Label 18mm Black Tapa Adhesiva 18mm Negra	S 16 und.  Suporte Plástico Plastic Support Soporte plastico	

FERRAGENS ESCALA REAL

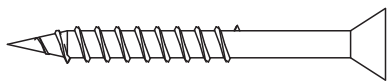

B - Parafuso 5,0 x 50 CC Phillips | 22 UND
Screw 5,0 x 50 CC Phillips | 22 UND
Tornillo 5,0 x 50 CC Phillips | 22 UND

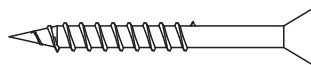

C - Parafuso 4,0 x 40 CC Phillips | 20 UND
Screw 4,0 x 40 CC Phillips | 20 UND
Parafuso 4,0 x 40 CC Phillips | 20 UND

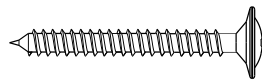

D - Parafuso 4,0 x 30 Franjeado | 08 UND
Screw 4,0 x 30 Franjeado | 08 UND
Tornillo 4,0 x 30 Franjeado | 08 UND

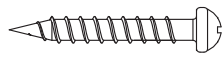

E - Parafuso 4,0 x 25 CP Phillips | 04 UND
Screw 4,0 x 25 CP Phillips | 04 UND
Tornillo 4,0 x 25 CP Phillips | 04 UND



F - Parafuso 3,5 x 12 CC Phillips | 20 UND
Screw 3,5 x 12 CC Phillips | 20 UND
Tornillo 3,5 x 12 CC Phillips | 20 UND



L - Prego Ardox 12 x 12 | 52 UND
Nail Ardox 12 x 12 | 52 UND
Clavo Ardox 12 x 12 | 52 UND

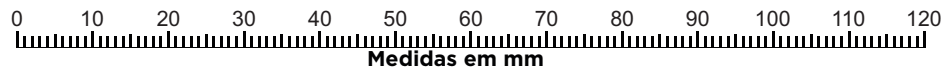

Medidas em mm

MONTAGEM DO PRODUTO / PRODUCT ASSEMBLY / MONTAJE DEL PRODUCTO



1º PASSO / STEP / PASO

Prepare as peças N°04, 05 e 15 utilizando porcas cilíndricas 'I'.
Prepare a peça N°03,04 e 05 utilizando cavilhas 'A'.
Fixe a lateral direita N°01 nas peças N°04 e 05 utilizando parafusos 5,0 x 50 CC Phillips 'B', após fixação cole as tampas adesivas 'P'.
Fixe a peça N°15 com a peça N° 03,04 e 05, após fixação cole as tampas adesivas 12mm 'P'.
Fixe as sapata lateral 'N' nas peças N°03 e 05 utilizando pregos 12x12 'L'.

Prepare the pieces N°04, 05 and 15 using 'I'.
Prepare the piece N°03,04 and 05 using 'A'.
Fix the right side N° 01 on the pieces N°04 and 05 using 'B' after fix 'P' up the screws.
Fix the piece N°15 on the N°05. After it, put 'P' upon the screws.
Fix 'N' using nails 12x12 'L'.

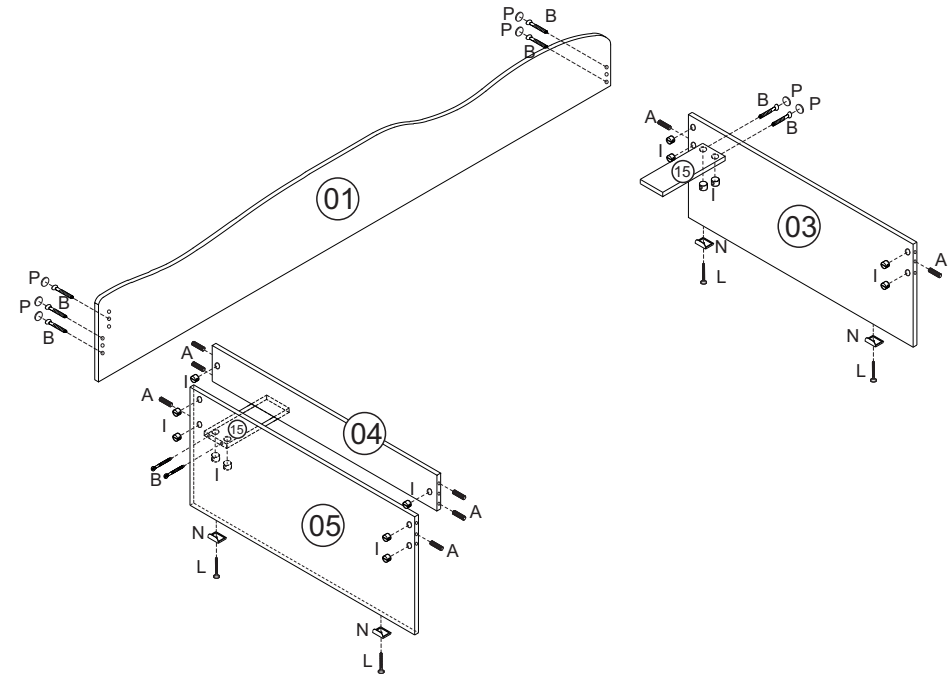
Prepárese las piezas N°04, 05 y 15 utilizando 'I'.
Prepárese las piezas N°03,04 y 05 con 'A'.
Fije la lateral N° 01 en las piezas N° 03,04 y 05 utilizando 'B' y 'P'.
Fije la pieza N°15 en la N°05, despues de eso, peguelas 'P'.
Fije 'N' con clavos 12x12 'L'.



A 08 und.  Cavilha 6 x 30 Dowel 6 x 30 Clavija 6 x 30	B 09 und.  Parafuso 5,0 X 50CC Phillips Screw 5,0 X 50CC Phillips Tornillo 5,0 X 50CC Phillips	I 14 und.  Porca Cilíndrica 12 x 09 Nut 12 x 09 Tuerca 12 x 09	N 04 und.  Sapata Lateral Side shoes Zapata lateral	P 07 und.  Tampa Adesiva Vermelha 12mm Adhesive label Red 12mm Tapa adhesiva Vermelha 12mm
---	--	--	---	--