

PRODUTO CONCLUÍDO
PRODUCTO TERMINADO
FINISHED PRODUCT

ITM/D333-
REV. 003

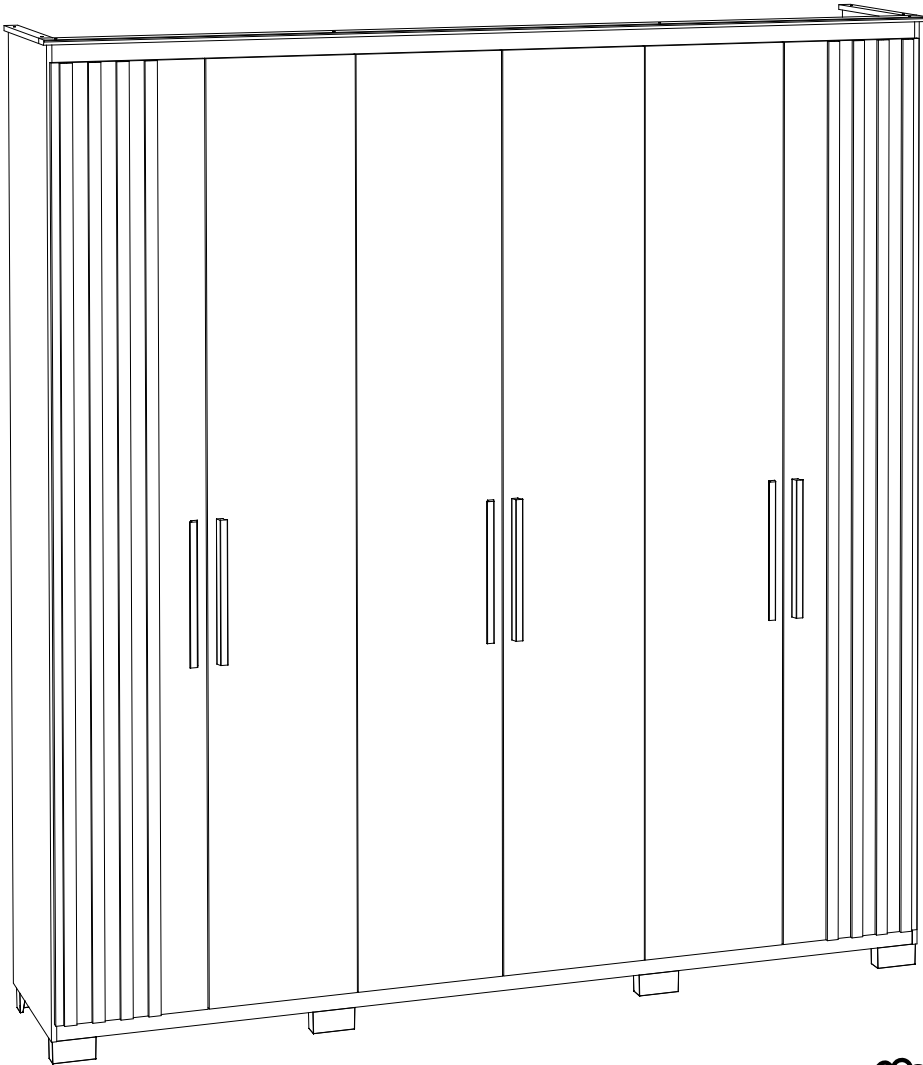

HENN

Ind. e Com. de Móveis Henn
Mondaí - SC - Brasil

+55 49 3674.3500

@moveishenn
www.henn.com.br

ITM/D333-

**INSTRUÇÕES DE
MONTAGEM**

INSTRUCCIONES DE MONTAJE
ASSEMBLY INSTRUCTIONS

ROUPEIRO ÁVILA 06 PORTAS 04 GAVETAS |
ARMARIO ÁVILA 06 PUERTAS 04 CAJONES | WARDROBE ÁVILA 06 DOORS 04 DRAWERS

D333-127 Nature/Off White

D333-128 Nature

D333-222 Nature/Avelã

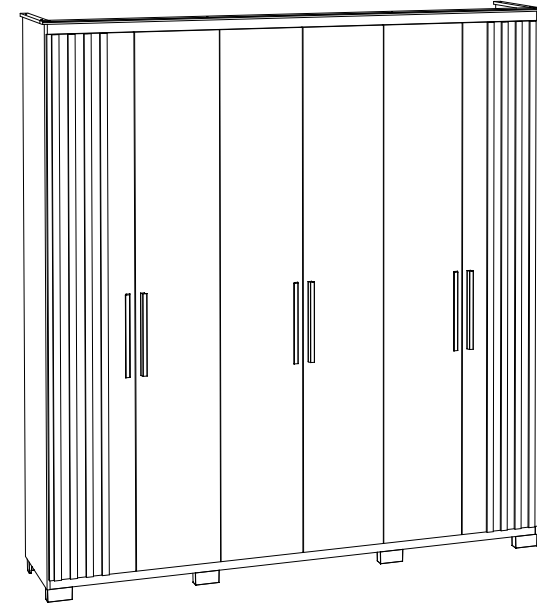

AVISO

Para limpeza de seu móvel, use uma flanela seca ou umedecida, e não utilize produtos químicos que possam danificar seu produto.

SISTEMA DE MONTAGEM

O sistema de montagem dos produtos, funciona de acordo com a ordem crescente dos números indicados no desenho. Ex: 01, 02, 03, 04... até a conclusão da montagem.

ASSISTÊNCIA TÉCNICA

Para solicitação de Assistência Técnica você consumidor deverá entrar em contato com o Lojista o qual você realizou a compra deste produto e solicitar a assistência técnica das peças avariadas. A garantia abrange todas as peças, partes e componentes que eventualmente venham apresentar defeito de fabricação no prazo de 03 (três) meses, contando a partir da entrega do produto ao consumidor, mediante nota fiscal de compra. Se houver qualquer alteração na estrutura do produto ou ocorrer defeito por negligência do montador/consumidor em relação a instrução de montagem e manuseio, não será fornecido assistência técnica gratuita.

ADVERTENCIA

Para limpieza de su móvil, use una franela seca o húmeda, y no utilice productos químicos que puedan dañar su producto.

SISTEMA DE MONTAJE

El sistema de montaje de los productos funciona de acuerdo con el orden creciente de los números indicados en el dibujo. Ej.: 01, 02, 03, 04... hasta la conclusión del montaje.

ASISTENCIA TÉCNICA

Para solicitar Asistencia Técnica, el consumidor debe comunicarse con el Comercio que usted realizó la compra de este producto y solicita asistencia técnica para las partes dañadas. La garantía cubre todas las partes, piezas y componentes que eventualmente puedan presentar defecto de fabricación en el plazo de 03 (tres) meses, contados a partir de la entrega del producto al consumidor, mediante factura de compra. Si se produce algún cambio en la estructura del producto o se produce un defecto por negligencia del montador/consumidor en relación con las instrucciones de montaje y manipulación, no se prestará asistencia técnica gratuita.

NOTICE

To clean your furniture, use a dry or wet cloth, and do not use chemicals that may damage your product.











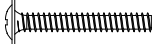

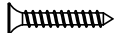



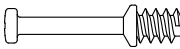

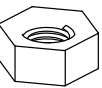
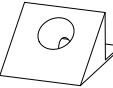

ASSEMBLY SYSTEM

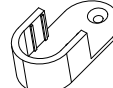
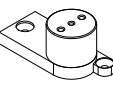
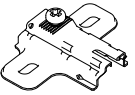
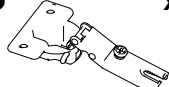
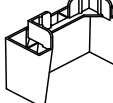
The products' assembly system works according to the increasing order of the indicated numbers. For example: 01, 02, 03, 04 ... to the end of the assembly.

TECHNICAL ASSISTANCE

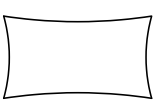

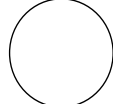

To request Technical Assistance, the consumer must contact the retailer from whom you purchased this product and request technical assistance for the damaged parts. The warranty covers all parts, parts and components that may eventually present a manufacturing defect within a period of 03 (three) months, counting from the delivery of the product to the consumer, by means of a purchase invoice. If there is any change in the structure of the product or defect occurs due to negligence of the assembler/consumer in relation to the assembly and handling instruction, free technical assistance will not be provided.

ACESSÓRIOS | ACCESORIOS | ACCESSORIES

A x42  Parafuso 3,5x40mm CHT.	B x12  Parafuso 3,5x25mm FLA.	C x16  Parafuso 4,0x22mm MET FLA.	D x40  Parafuso 3,5x22mm CHT.
E x8  Parafuso 3,0x16mm CHT.	F x208  Parafuso 3,5x12mm CHT.	G x145  Prego 10x10mm	H x45  Fixador de Fundos
I x2  Parafuso Minifix	J x2  Tambor Minifix	K x94  Cavilha Plástica 5x25mm	L x8  Prego 12x12mm Anelado
M x16  Porca Sextavada	N x8  Cantoneira Suporte Triangular	O x20  Cantoneira Plástica 20x20mm	P x4  Suporte Cabideiro Oblongo
Q x16  Distanciador de Corrediça	R x24  Calço Metal 5mm	S x24  Dobradiça Metal 26mm Colo Alto	T x8  Pé "U" 50x40x100mm
U x4  Corrediça Telescópica 300mm	V x6  Perfil Puxador Revestido 330mm	W x2  Cabideiro Alumínio Oblongo 681mm Estriado	X x3  Perfil "H" 1720mm
Y x2  Sachê de Cola	Z x2  Giz de Correção	AA x4  Adesivo Tapa Parafuso 17mm	AB x74  Adesivo Tapa Parafuso 10mm
AC x1  Etiqueta Resinada Henn			

MONTAGEM 10 | MONTAJE 10 | ASSEMBLY 10

ACESSÓRIOS REQUERIDOS

Z		02
AA		04
AB		74
AC		01

Pesos máximos recomendados com carga distribuída
Peso máximo recomendado con la carga distribuida
Recommended maximum weight with distributed load.

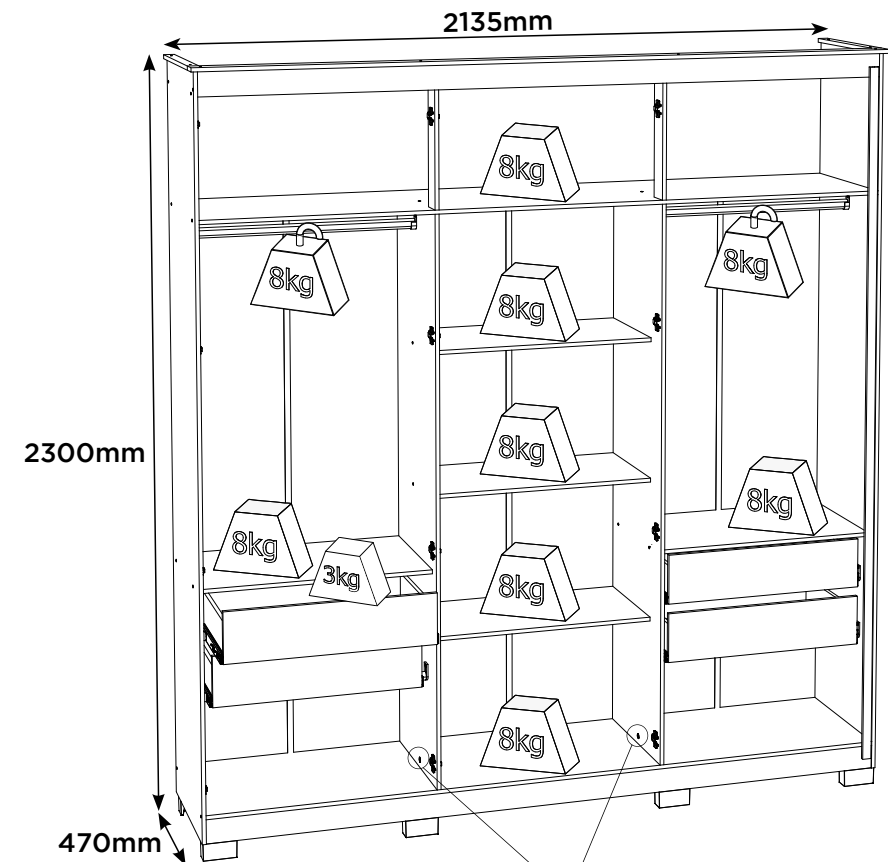

PERFECT CORRECTION
CORRECCIÓN PERFECTA

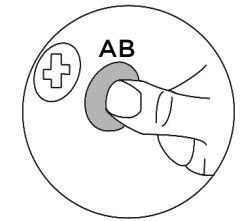
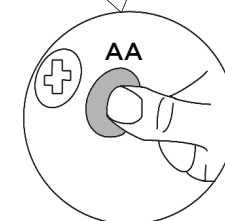
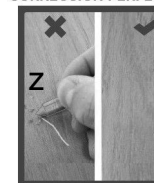



PEÇAS REQUERIDAS

ACESSÓRIOS REQUERIDOS

FERRAMENTAS NECESSÁRIAS

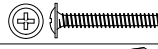
24	PORTA APLIQUE	x2
26	PORTA	x4

B		12
V		06

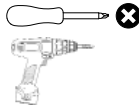

Para portas (24 e 26): fazer furação passante para puxador (V)

Para la puertas (24 e 26): hacer agujeros pasantes para la manija (V)

For doors (24 e 26): make through holes for handle (V)

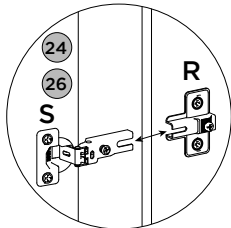
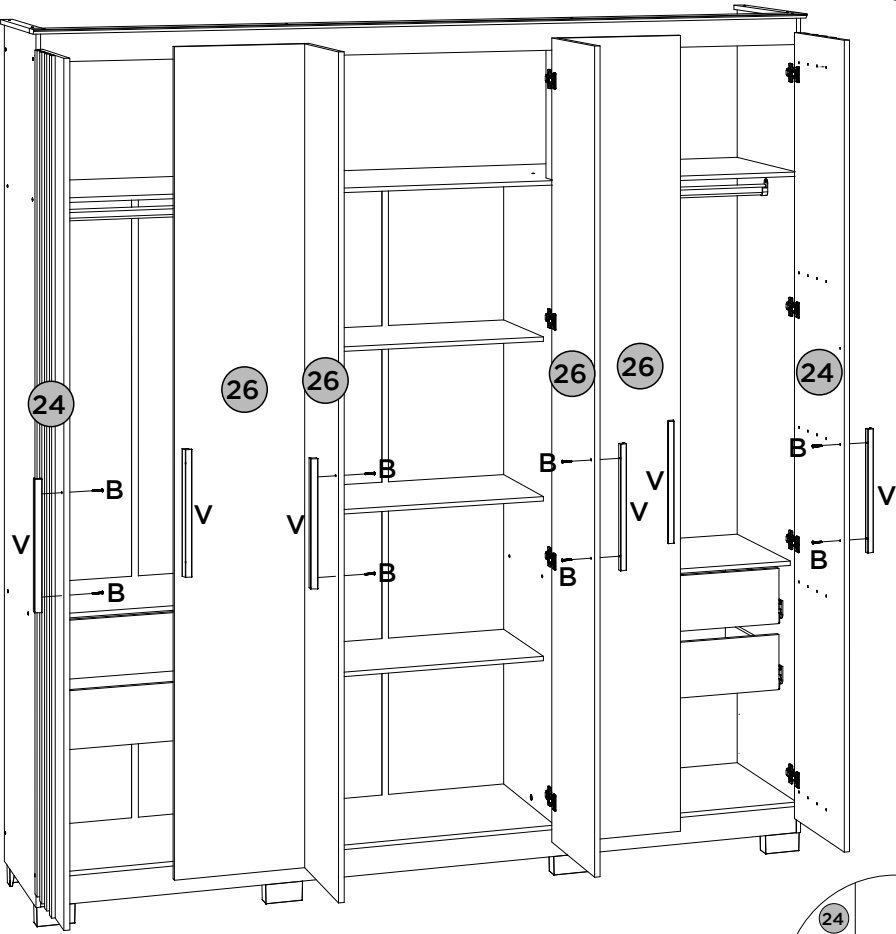
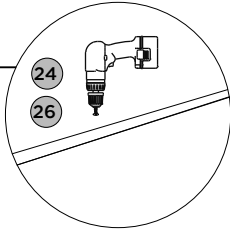

PARAFUSOS EM ESCALA 1:1 | TORNILLOS A ESCALA 1:1 | 1:1 SCALE SCREWS

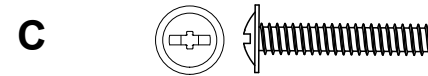
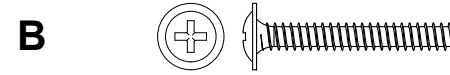
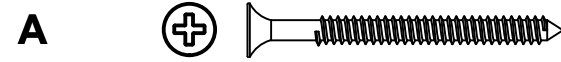

Item	Caixa Caja Box	Qty Ctd Qty	Descrição Descripción Description	Dimensões (mm) Dimensiones (mm) Dimensions (mm)		
				Comprimento Largo Length	Largura Ancho Width	Espessura Grosor Thickness
1	2/3	1	RODAPÉ FRONTAL FALDÓN DELANTERO FRONT SKIRTING	2091	73	12
2	1/3	2	TRAVESSA DO RODAPÉ PLACA DE RODAPIÉ SKIRTING PLATE	415	73	12
3	2/3	1	RODAPÉ TRASEIRO REPOSAPIÉS TRASERO BACK FOOTBOARD	2091	73	12
4	2/3	1	BASE BASE BASE	2091	445	12
5	1/3	1	LATERAL ESQUERDA LATERAL IZQUIERDA LEFT SIDE	2238	445	12
6	1/3	1	DIVISÃO ESQUERDA DIVISIÓN IZQUIERDA LEFT DIVISION	1718	445	12
7=13	1/3	1	TAMPO DAS GAVETAS TAPA DE LOS CAJONES TOP OF DRAWERS	689	400	12
8	1/3	1	DIVISÃO DIREITA DIVISIÓN DERECHA RIGHT DIVISION	1718	445	12
9	1/3	3	PRATELEIRA ESTANTE SHELF	689	350	12
10	2/3	1	CHÃO DO MALEIRO REPISA SUPERIOR FLOOR OF MALEIRO	2091	445	12
11	1/3	2	RIPA DO MALEIRO TRAVESAÑO SUPERIOR MALEIRO'S LATH	350	73	12
12	1/3	1	LATERAL DIREITA LADO DERECHO RIGHT SIDE	2238	445	12
13=7	1/3	1	TAMPO DAS GAVETAS TAPA DE LOS CAJONES TOP OF DRAWERS	689	400	12
14	2/3	1	TAMPO TAPA TOP	2091	433	12
15	1/3	1	FUNDO SUPERIOR FONDO TOP TOP FUND	2109	367	3
16	3/3	6	FUNDO FONDO BOTTOM	1736	348	3
17	2/3	1	CHAPÉU SOMBRERO HAT	2091	73	12
18	1/3	2	MOLDURA LATERAL MARCO LATERAL LATERAL FRAME	408	32	12
19	2/3	1	MOLDURA FRONTAL CORNIJA FRONTAL FRONT FRAME	2135	60	12
20	1/3	4	FRENTE DE GAVETA FRENTE DE CAJÓN FRONT OF DRAWER	631	152	12
21	1/3 e 2/3	8	LADO DE GAVETA LADO DEL CAJÓN SIDE OF DRAWER	350	110	12
22	2/3	4	FUNDO DE GAVETA RECORTADO FONDO DEL CAJÓN RECORTADO CROPPED DRAWER BOTTOM	601	361	3
23	1/3 e 2/3	4	RIPA DE TRÁS MALLA DETRÁS REAR LATH	614	110	12
24	3/3	02	PORTA APLIQUE PUERTA APLICARSE APPLY DOOR	2158	347	15
25	3/3	08	APLIQUE APLICARSE APPLY	2157	28	9
26	3/3	04	PORTA PUERTA DOOR	2158	347	15

ACESSÓRIOS REQUERIDOS

FERRAMENTAS NECESSÁRIAS

E		08
F		24
N		08
U		04



4x

4º

Deixar 3mm de distância da frente de gaveta.

Deje una separación de 3mm del frente del cajón.

Leave 3mm away from the front of the drawer.

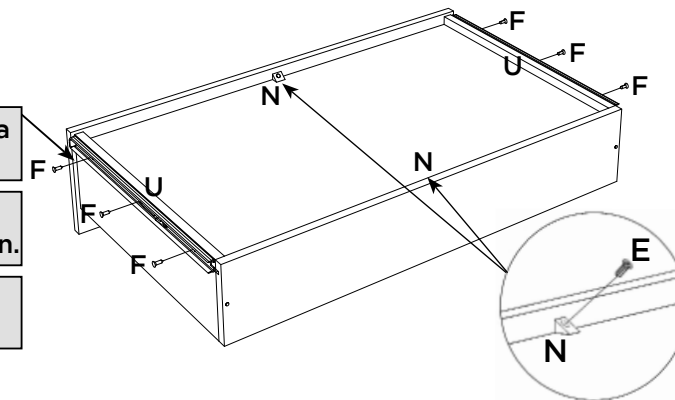

O975-64 KIT ESPELHO 800x280x3 COM 4 UNIDADES

Esse Kit Espelho é opcional e é vendido separadamente.

Este juego de espejos es opcional y se vende por separado.

This Mirror Kit is optional and sold separately.

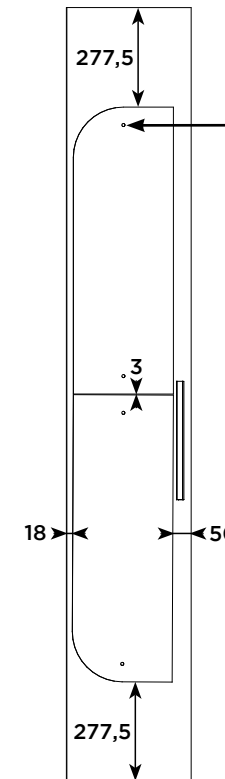

Fixar o Espelho com a Bucha e o Parafuso, que acompanha o kit.

Arreglar el espejo con el Casquillo y Tornillo, que viene con el kit.

Attach the Mirror with the Bushing and Screw, which accompanies the kit.

Utilizar a parafusadeira com o torque 3.

Utilice el destornillador con torque 3.

Use the screwdriver with torque 3.

Medidas em mm
Medidas en mm
Measurements in mm

PEÇAS REQUERIDAS

ACESSÓRIOS REQUERIDOS

FERRAMENTAS NECESSÁRIAS

20	FRENTE DE GAVETA	x4
21	LADO DE GAVETA	x8
22	FUNDO DE GAVETA RECORTADO	x4
23	RIPA DE TRÁS	x4

F		16
L		08
O		08
Y		

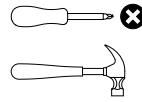

4x

1º

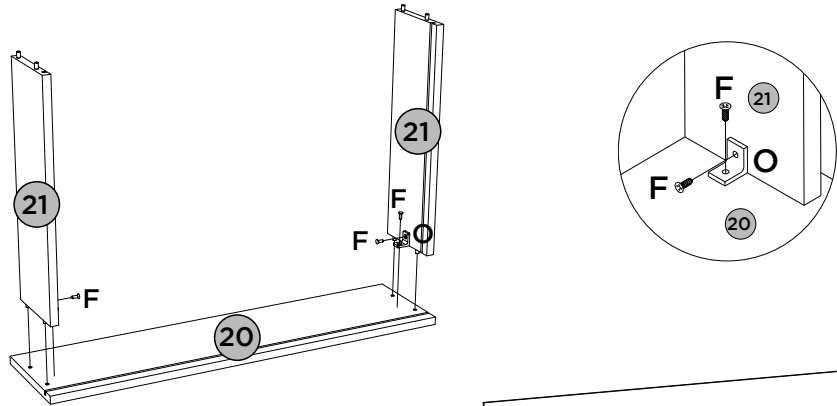

4x

2º

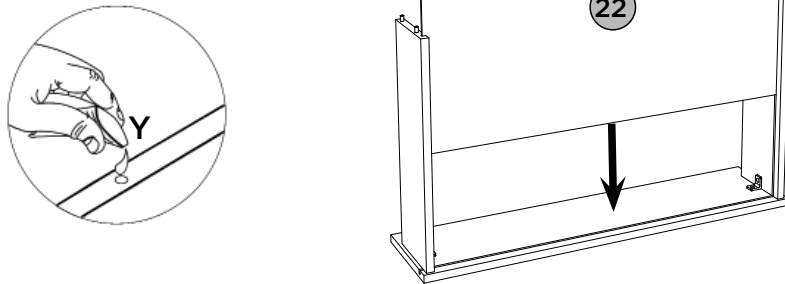

4x

3º

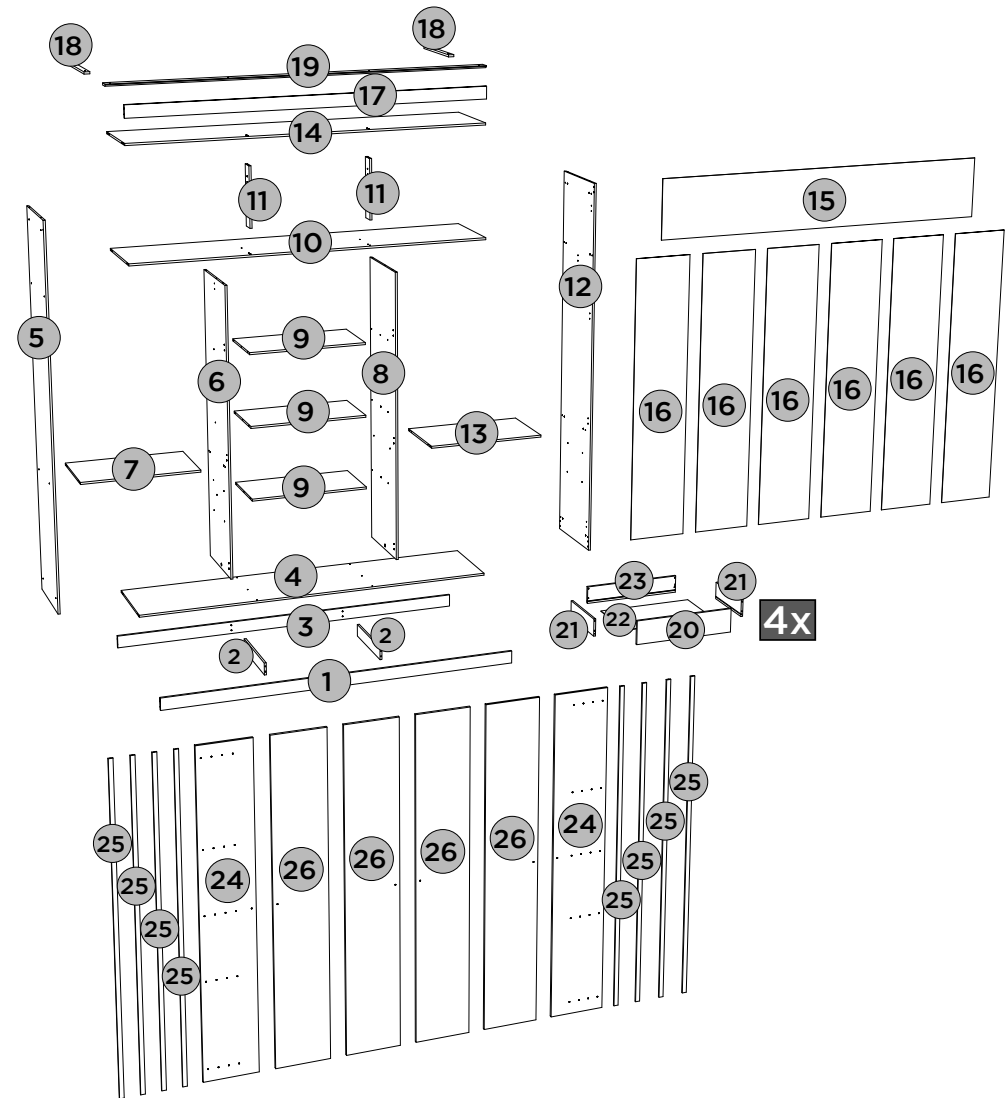
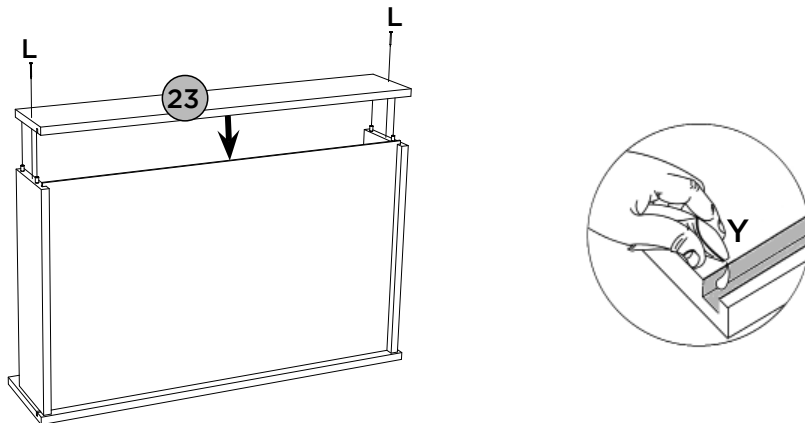

REQUISITOS PARA MONTAGEM
REQUISITOS PARA LA MONTAJE | ASSEMBLY REQUIREMENTS.

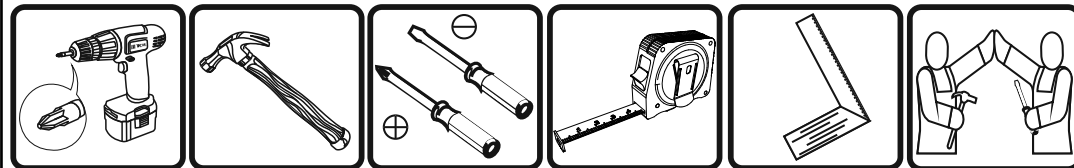

Imagens meramente ilustrativas, não acompanha o produto.
Imágenes ilustrativas, no incluidas con el producto.
Illustrative images, not included with the product.

PEÇAS REQUERIDAS

1	RODAPÉ FRONTAL	x1
2	TRAVESSA DO RODAPÉ	x2
3	RODAPÉ TRASEIRO	x1
11	RIPA DO MALEIRO	x2
17	CHAPÉU	x1

ACESSÓRIOS REQUERIDOS

F		04
K		22
O		04

FERRAMENTAS NECESSÁRIAS

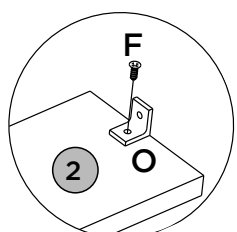
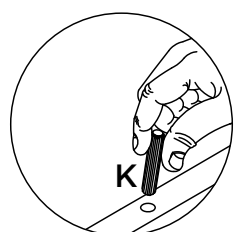
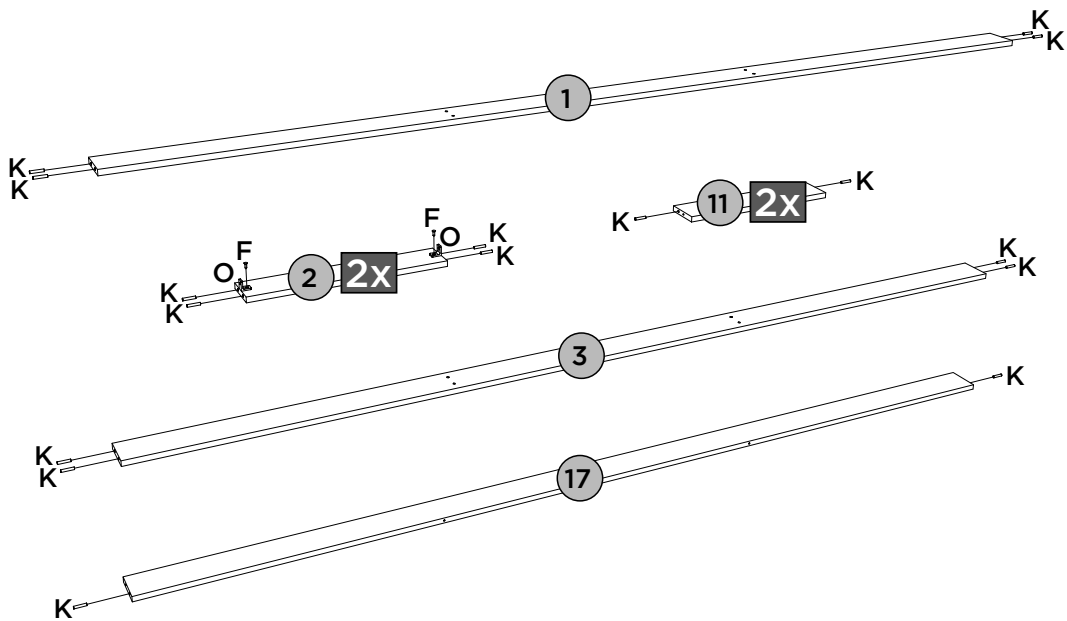
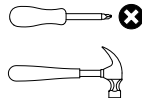

PEÇAS REQUERIDAS

18	MOLDURA LATERAL	x2
19	MOLDURA FRONTAL	x1

ACESSÓRIOS REQUERIDOS

A		08
C		16
F		16
M		16
R		16

FERRAMENTAS NECESSÁRIAS

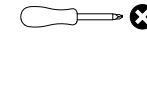

U		04
W		02

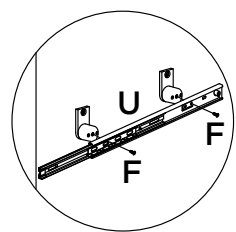
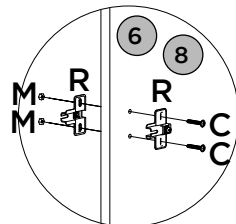
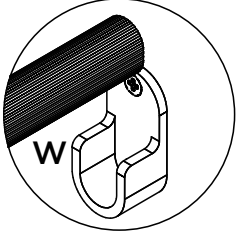
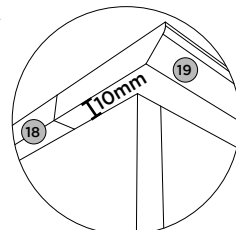
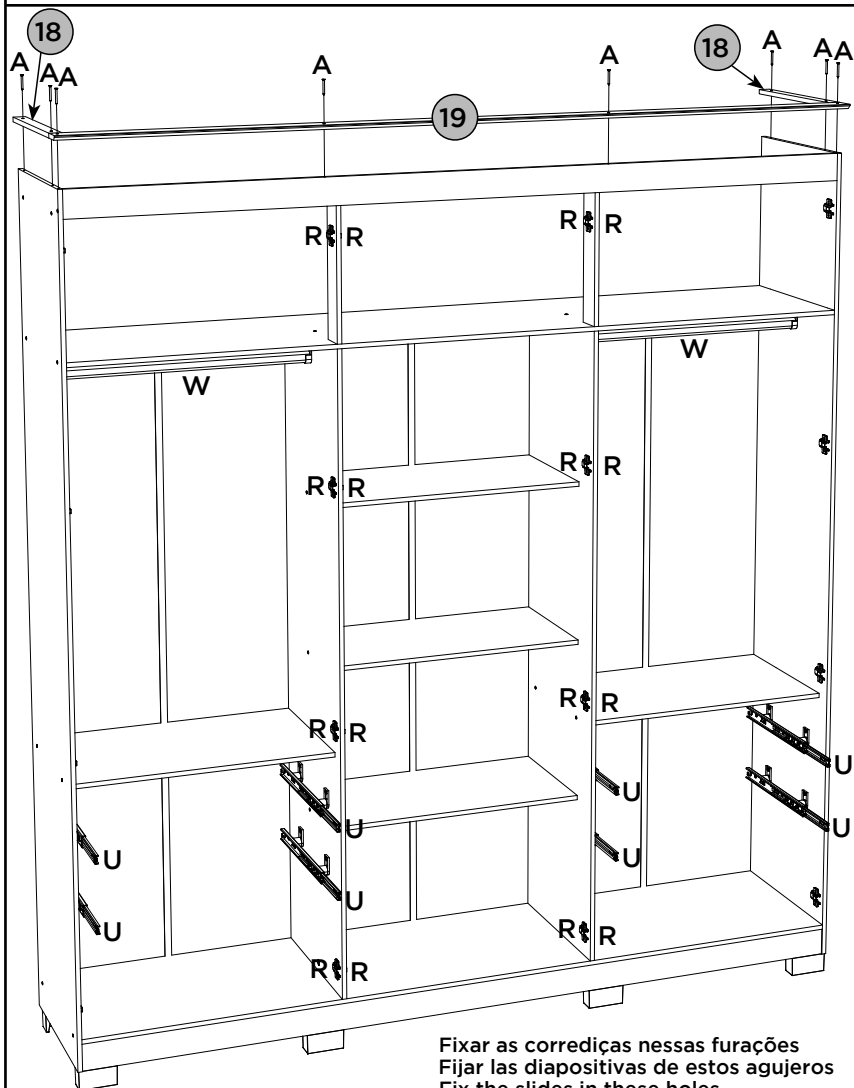

Fixar as correias nessas furações
Fijar las diapositivas de estos agujeros
Fix the slides in these holes

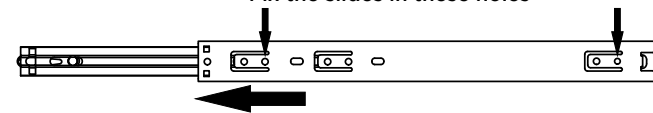

PEÇAS REQUERIDAS

15	FUNDO SUPERIOR	x1
16	FUNDO	x6
17	CHAPÉU	x1

ACESSÓRIOS REQUERIDOS

A		02
F		04
G		145
H		45
O		02
X		03

FERRAMENTAS NECESSÁRIAS

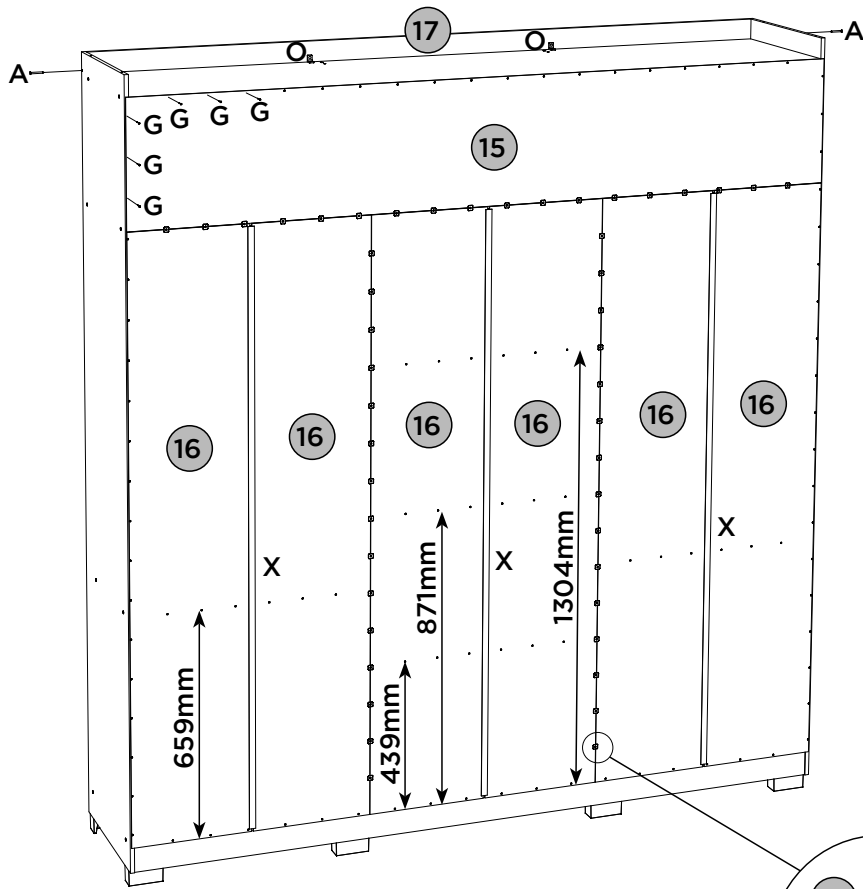
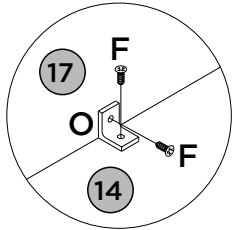
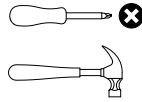

Fixar os pregos a uma distância de 120mm de um para outro.
 Fijar las uñas a un distancia de 120mm uno a otro.
 Fix the nails at a distance of 120mm from one to the other

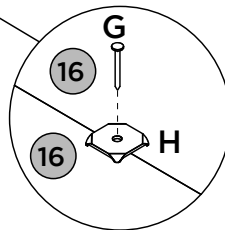

PEÇAS REQUERIDAS

4	BASE	x1
7=13	TAMPO DAS GAVETAS	x2
9	PRATELEIRA	x3
10	CHÃO DO MALEIRO	x1
14	TAMPO	x1

ACESSÓRIOS REQUERIDOS

I		02
K		32

FERRAMENTAS NECESSÁRIAS

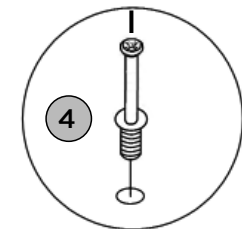
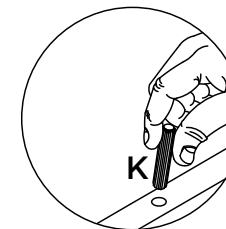
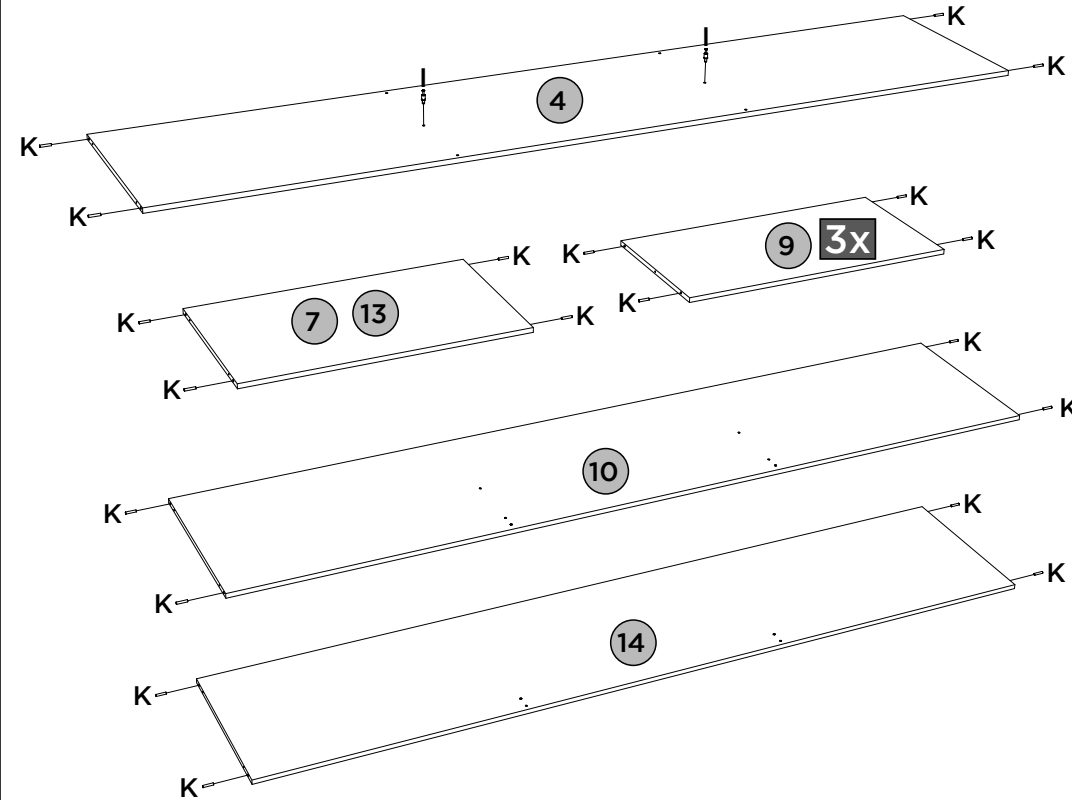
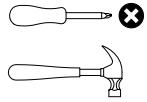

PEÇAS REQUERIDAS

5	LATERAL ESQUERDA	x1
6	DIVISÃO ESQUERDA	x1
8	DIVISÃO DIREITA	x1
12	LATERAL DIREITA	x1

ACESSÓRIOS REQUERIDOS

F		56
K		08
P		04
Q		16
R		08

FERRAMENTAS NECESSÁRIAS

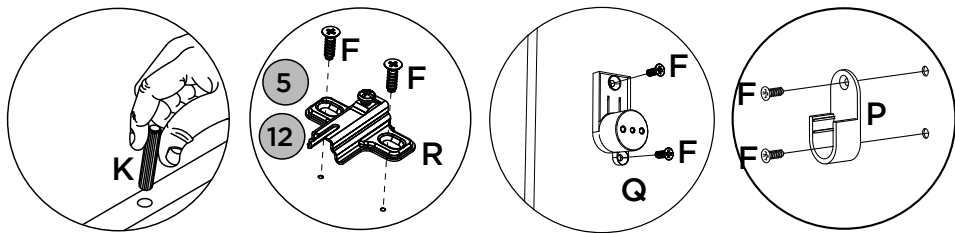
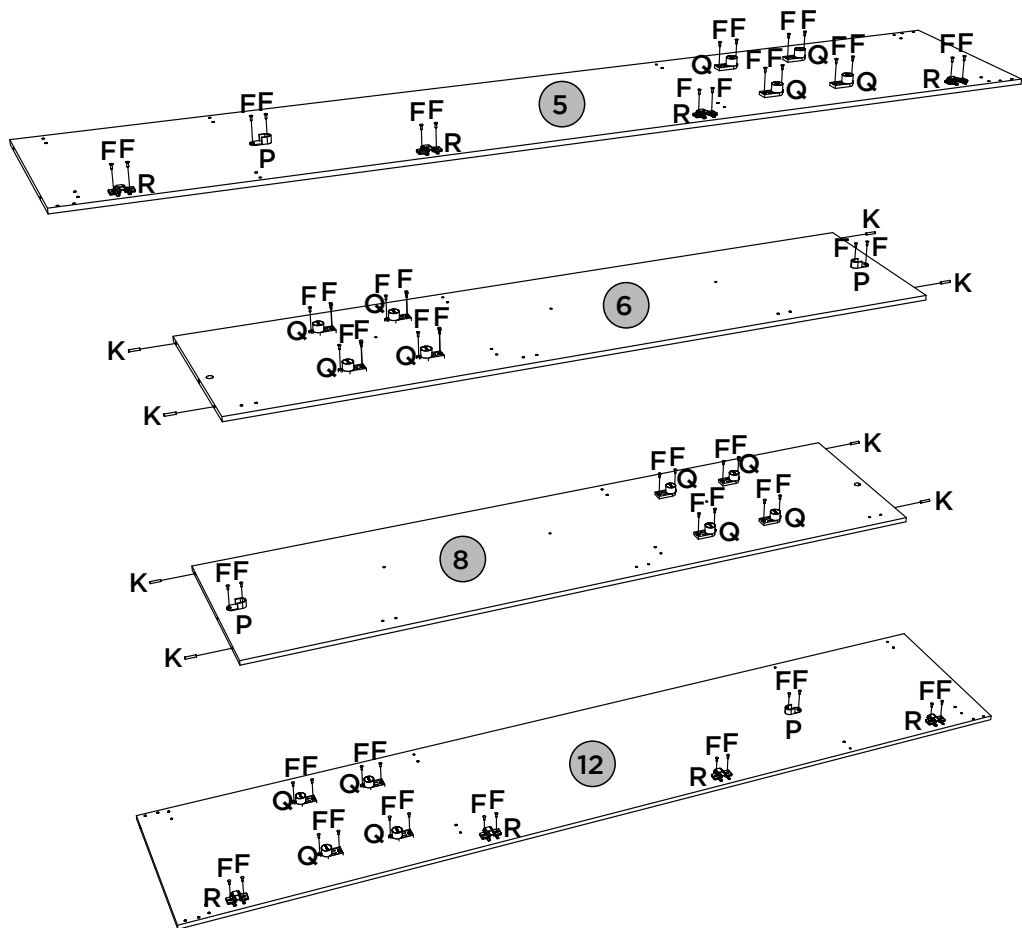
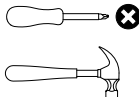

PEÇAS REQUERIDAS

10	CHÃO DO MALEIRO	x1
11	RIPA DO MALEIRO	x2
12	LATERAL DIREITA	x1
13=7	TAMPO DAS GAVETAS	x1
14	TAMPO	x1

ACESSÓRIOS REQUERIDOS

A		20
---	--	----

FERRAMENTAS NECESSÁRIAS

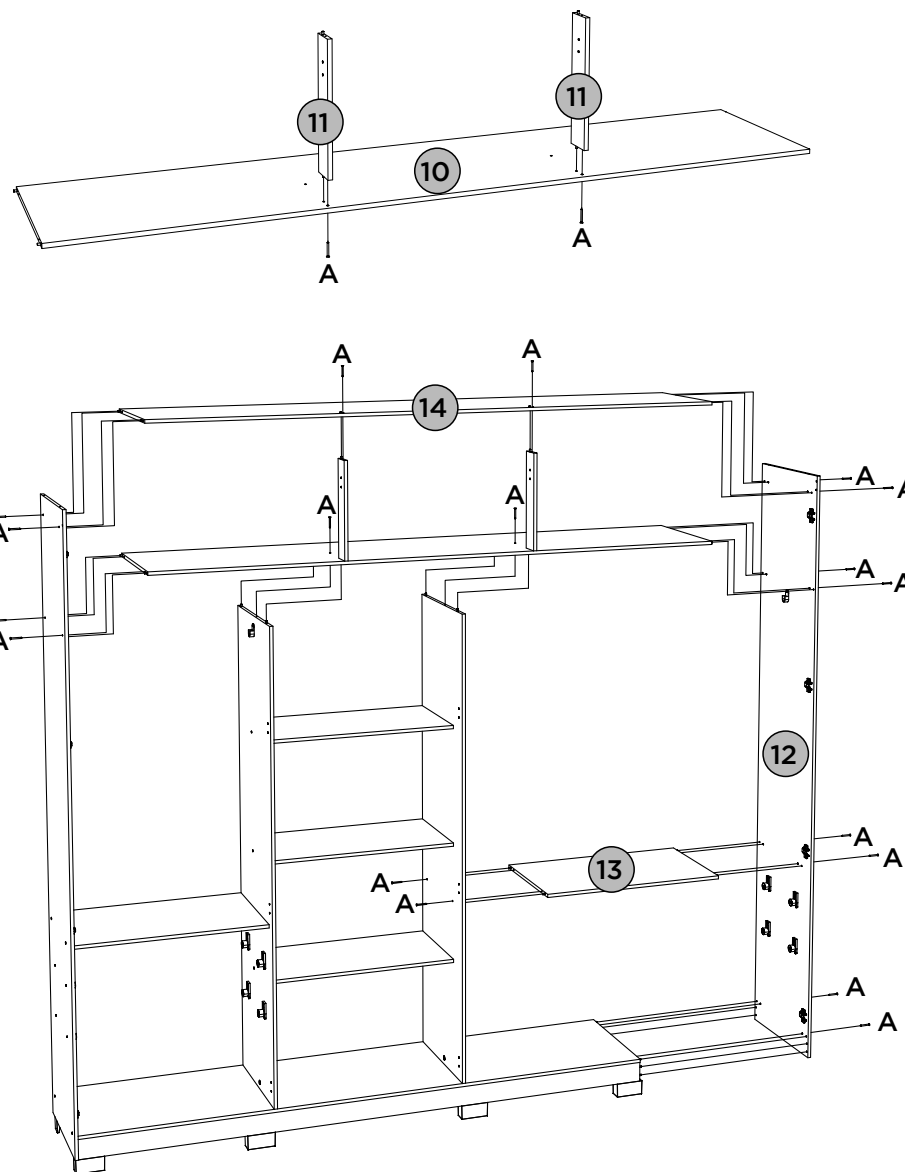
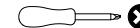



PEÇAS REQUERIDAS

ACESSÓRIOS REQUERIDOS

FERRAMENTAS NECESSÁRIAS

8	DIVISÃO DIREITA	x1
9	PRATELEIRA	x3

A		06
J		01

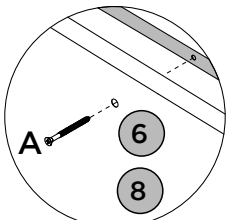
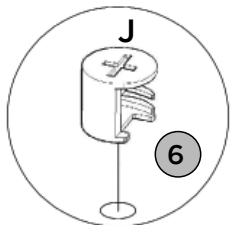
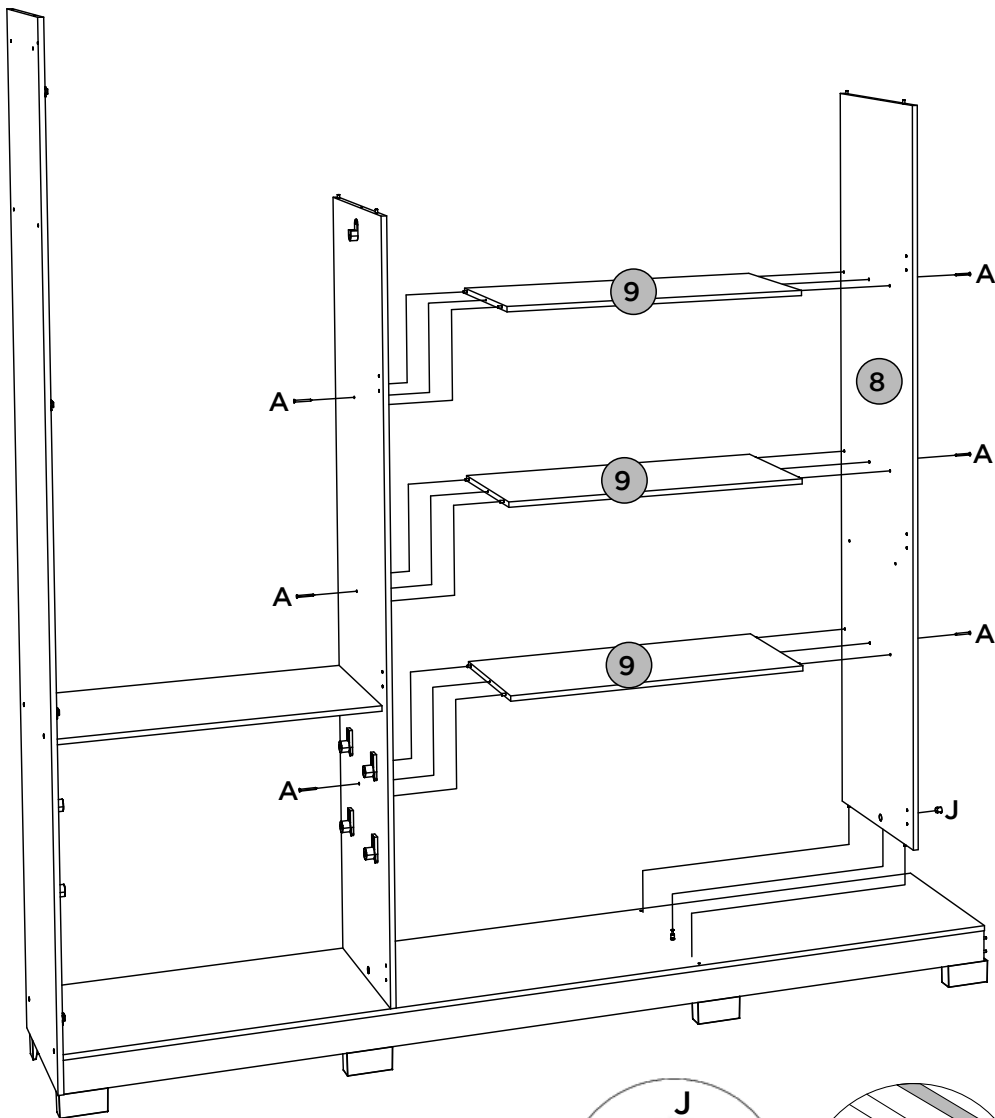
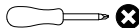



PEÇAS REQUERIDAS

ACESSÓRIOS REQUERIDOS

FERRAMENTAS NECESSÁRIAS

21	LADO DE GAVETA	x8
----	----------------	----

K		32
Y		

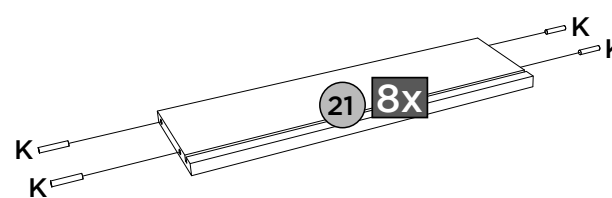



PEÇAS REQUERIDAS

ACESSÓRIOS REQUERIDOS

FERRAMENTAS NECESSÁRIAS

24	PORTA APLIQUE	x2
25	APLIQUE	x8
26	PORTA	x4

D		40
F		48
S		24

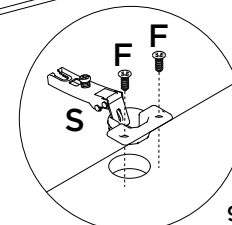
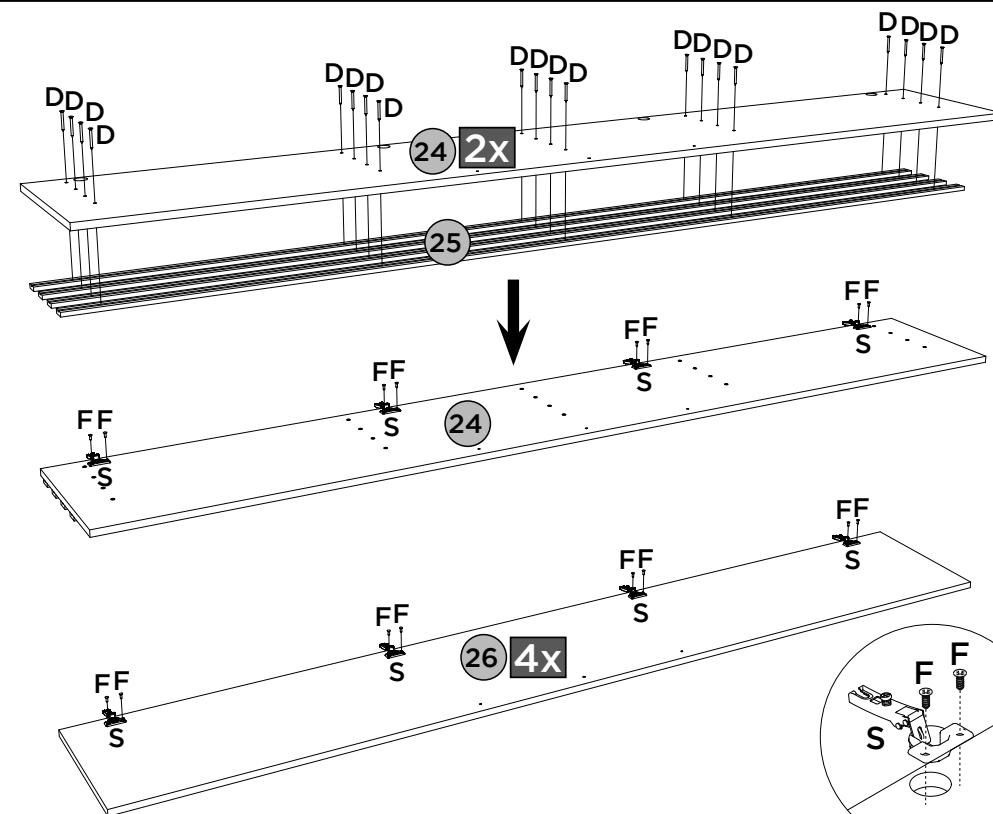
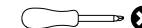

MONTAGEM 1 | MONTAJE 1 | ASSEMBLY 1

ITM/D333-

PEÇAS REQUERIDAS

1	RODAPÉ FRONTAL	x1
2	TRAVESSA DO RODAPÉ	x2
3	RODAPÉ TRASEIRO	x1

ACESSÓRIOS REQUERIDOS

F		04
---	--	----

FERRAMENTAS NECESSÁRIAS

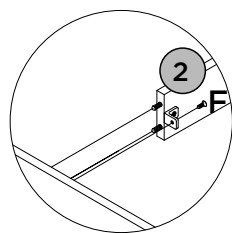
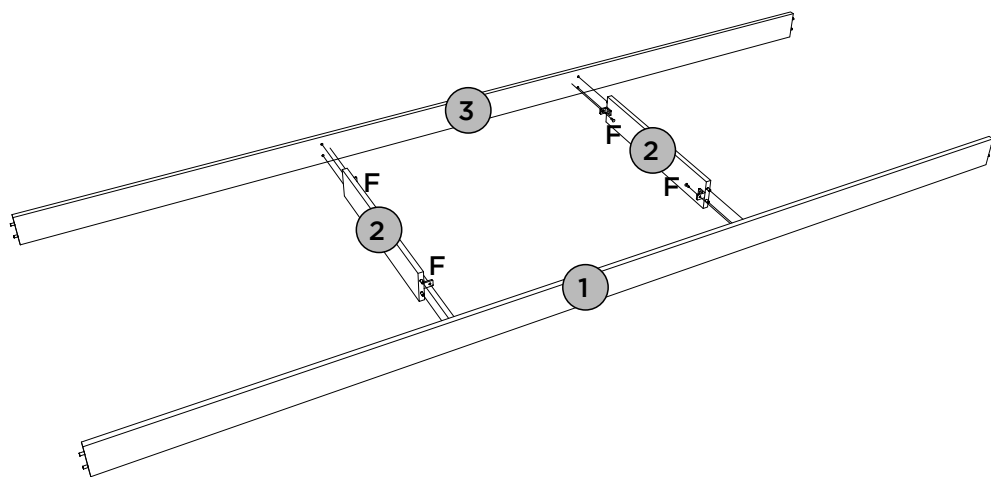

MONTAGEM 2 | MONTAJE 2 | ASSEMBLY 2

ITM/D333-

PEÇAS REQUERIDAS

4	BASE	x1
5	LATERAL ESQUERDA	x1
6	DIVISÃO ESQUERDA	x1
7	TAMPO DAS GAVETAS	x1

ACESSÓRIOS REQUERIDOS

A		06
F		36
J		01
O		06
T		08

FERRAMENTAS NECESSÁRIAS

