

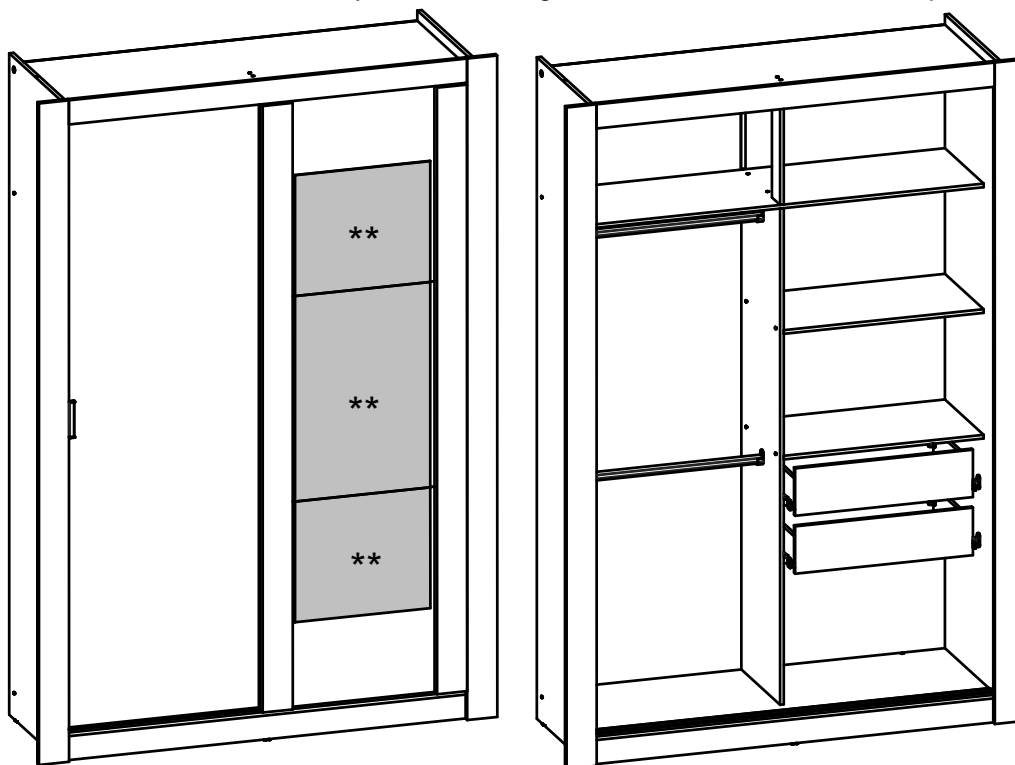

CARRARO
MÓVEIS

Ref. 1094

Ropero 2 Puertas Correderas 2 Cajones / 2-Sliding Door 2-Drawer Wardrobe / Roupeiro 2 Portas Correr 2 Gavetas



** Espejos Opcionales
 ** Mirrors Optional
 ** Espelhos Opcionais

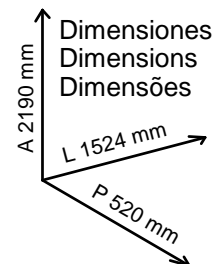

(A) Parafuso 4 x 12 116 un.	(B) Parafuso 4 x 12 24 un.	(C) Parafuso 3,5 x 20 2 un.	(D) Parafuso 4 x 20 2 un.	(E) Parafuso 4 x 25 40 un.	(F) Parafuso 4,5 x 50 30 un.
(G) 6 x 30 19 un.	(H) 6 x 50 1 un.	(I) 30 un.	(J) 66 un.	(K) 2 un.	(L) 2 un.
(M) 10 un.	(N) 12 un.	(O) 6 un.	(P) 6 un.	(Q) 2 un.	(R) 8 un.
(S) 10 un.	(T) 4 un.	(U) Pegamento Glue Cola 1 un.	(V) 4 un.	(W) 4 un.	(X) 8 un.
(Y) 1 un.	(Z) 20 un. 22 un.				

Herramientas
Tools
Ferramentas



90 min.



Personas Necessarias
People Required
Pessoas Necessárias

2



Consejos de Conservación

- No debe utilizarse en la limpieza, abrasivos como lana de acero, alcohol, vinagre, limón, o productos corrosivos que puedan rayar o quitar la película protectora en los muebles.
- Cuando la limpieza de muebles en general, napa y formica, deben utilizarse un paño ligeramente humedecido y jabón suave.
- Para mover el móvil, es importante que este se eleve desde el suelo, debido a que el arrastre puede causar daño estructural.
- No deje a su móvil en exposición a la intemperie.

Conservation Tips

- Do not use abrasive products to clean such as steel wool, alcohol, vinegar, lemon, scouring powder, or corrosive products which can scratch or peel off the protective film of the furniture.
- The best way to clean your furniture is to use a slightly moistened cloth with a mild soap.
- To move the furniture assembled, it is important that it is lifted off the ground, because the drag it can cause structural damage.
- Do not leave your furniture in weather exposure.

Dicas de Conservação

- Não utilizar na limpeza produtos abrasivos tais como: palha de aço, álcool, vinagre, limão, saponáceo, ou produtos corrosivos que possam riscar ou descolar a película protetora dos móveis.
- Na limpeza de móveis em geral, naps e fórmicas, deve ser utilizado um pano levemente umedecido e sabão neutro.
- Para a movimentação do móvel, é importante que este seja levantado do chão, pois ao arrastá-lo pode causar avarias estruturais.
- Não deixe o móvel em exposição a intempéries.

Certificado de Garantia

A garantia dos produtos fabricados pela Carraro, abrange eventuais defeitos/vícios de fabricação, no prazo estabelecido pelo Código de Defesa do Consumidor, em seu artigo 26,II, o qual prevê a garantia legal de 90 (noventa) dias.

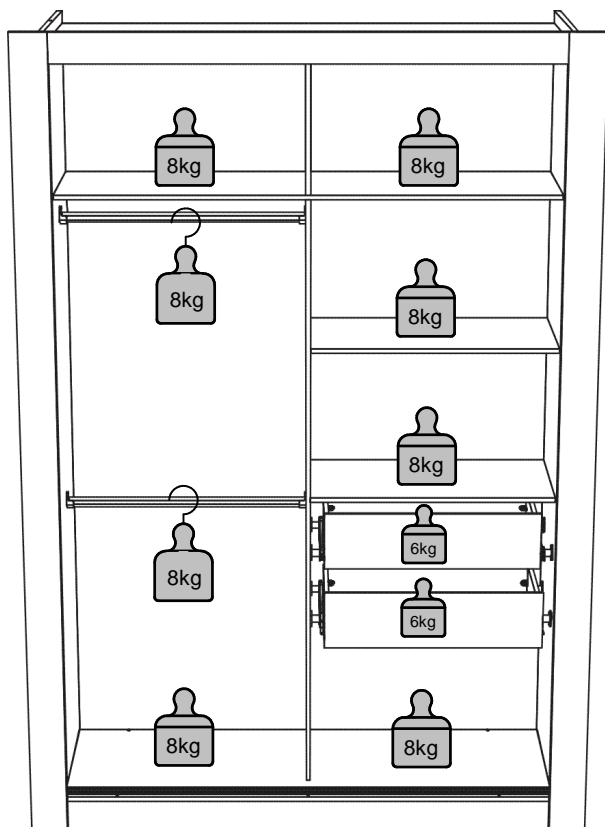

Peso por estante

Por favor, preste atención a los pesos máximos admitidos por cada compartimento del producto. Tenga cuidado de no exceder estos pesos, con el fin de garantizar la calidad y durabilidad del producto.

Es importante recordar que los pesos muestran en caso de ser distribuida en toda el área de la plataforma.

Weight per shelf

Please pay attention to the maximum weights supported by each compartment product. Be careful not to exceed these weights, in order to ensure the quality and durability of the product. It is important to remember also that the weights shown should be distributed throughout the area of the shelf.

Peso por Prateleira

Ao lado são demonstrados os pesos máximos suportados por cada compartimento do produto. Cuide para não exceder esses pesos, afim de garantir a qualidade e a durabilidade do mesmo. É importante lembrar também, que os pesos mostrados devem ser DISTRIBUÍDOS ao longo de toda a área da peça.

LISTA DE PIEZAS / LIST OF PARTS / RELAÇÃO DE PEÇAS

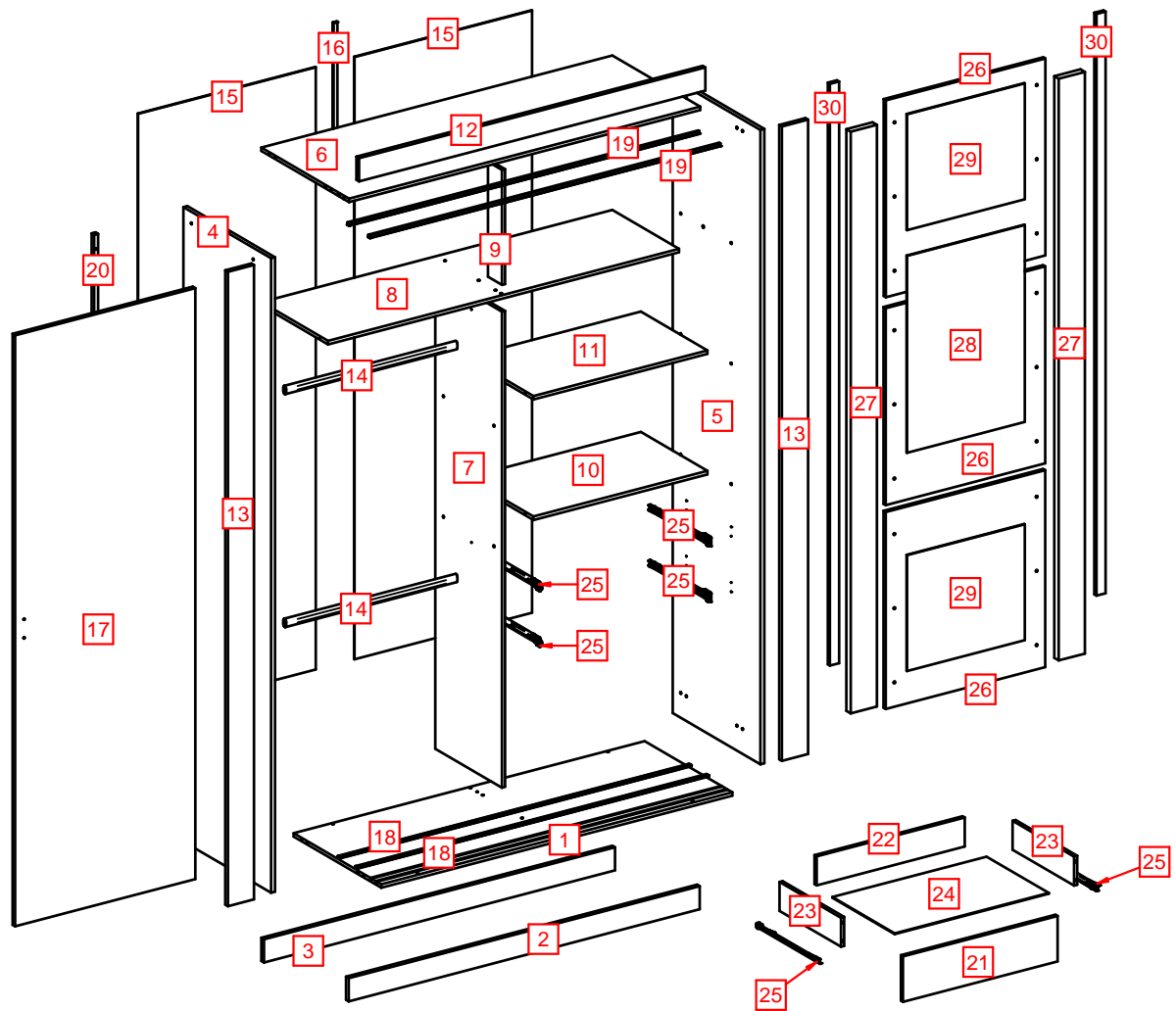

#	Qtde.	Espanhol	Inglês	Português	Dimensões	#	Qtde.	Espanhol	Inglês	Português	Dimensões
1	1	Base	Base	Base	1342 x 500 x 12	17	1	Puerta Correr Lateral	Side Sliding Door	Porta Correr Lateral	2040 x 689 x 15
2	1	Rodape Delantero	Front Baseboard	Rodapé Dianteiro	1342 x 80 x 15	18	2	Trilho Inferior	Lower Profile	Trilho Inferior	Compr. 1341mm
3	1	Rodape Trasero	Back Baseboard	Rodapé Traseiro	1342 x 80 x 15	19	2	Trilho Superior	Upper Profile	Trilho Superior	Compr. 1341mm
4	1	Lateral Izquierda	Left Side	Lateral Esquerda	2190 x 500 x 15	20	1	Soporte Trasero Puerta	Door Support	Desempenador	1500 x 15 x 15 x 0,90
5	1	Lateral Derecha	Right Side	Lateral Direita	2190 x 500 x 15	21	2	Frente de Cajón	Drawer Front	Frente de Gaveta	591 x 157 x 12
6	1	Tapa	Top	Tampo	1342 x 500 x 12	22	2	Costado Cajón	Drawer Back	Costa de Gaveta	566 x 100 x 12
7	1	División	Division	Divisão	1643 x 380 x 12	23	4	Lateral del Cajón	Drawer Side	Lateral de Gaveta	350 x 100 x 12
8	1	Tapa Intermediaria	Intermediate Top	Tampo Intermediário	1342 x 380 x 12	24	2	Fondo Cajón	Drawer Bottom	Fundo de Gaveta	589 x 355 x 2,8
9	1	Pilastra	Pilaster	Pilastra	397 x 80 x 12	25	2	Corredera Metalica	Metallic Runner	Corrediça Metálica	350mm
10	1	Tapa Cajones	Drawer Top	Tampo Gavetas	665 x 380 x 12	26	3	Panel Puerta Corred.	Sliding Door Panel	Painel Pta. Correr	680 x 610 x 12
11	1	Pratelera	Shelf	Prateleira	665 x 380 x 12	27	2	Moldura Puerta Corred.	Sliding Door Frame	Moldura Pta. Correr	2008 x 100 x 25
12	1	Moldura Superior	Upper Frame	Moldura Superior	1324 x 80 x 15	28	1	Espejo Maior	Biggest Mirror	Espelho Maior	680 x 450 x 3
13	2	Moldura Lateral	Side Frame	Moldura Lateral	2190 x 100 x 15	29	2	Espejo Menor	Smaller Mirror	Espelho Menor	400 x 450 x 3
14	2	Rolizo Percha	Hanger Rail	Cabideiro	28 x 16 x 0,45 x 655	30	2	Moldura Tras. Puerta Corred.	Back Frame Sliding Door	Moldura Tras. Pta. Correr	2008 x 35 x 12
15	2	Costado	Back	Costa	2079 x 679 x 2,8						
16	1	Perfil I	Profile I	Perfil I	395 x 15 x 6						

1

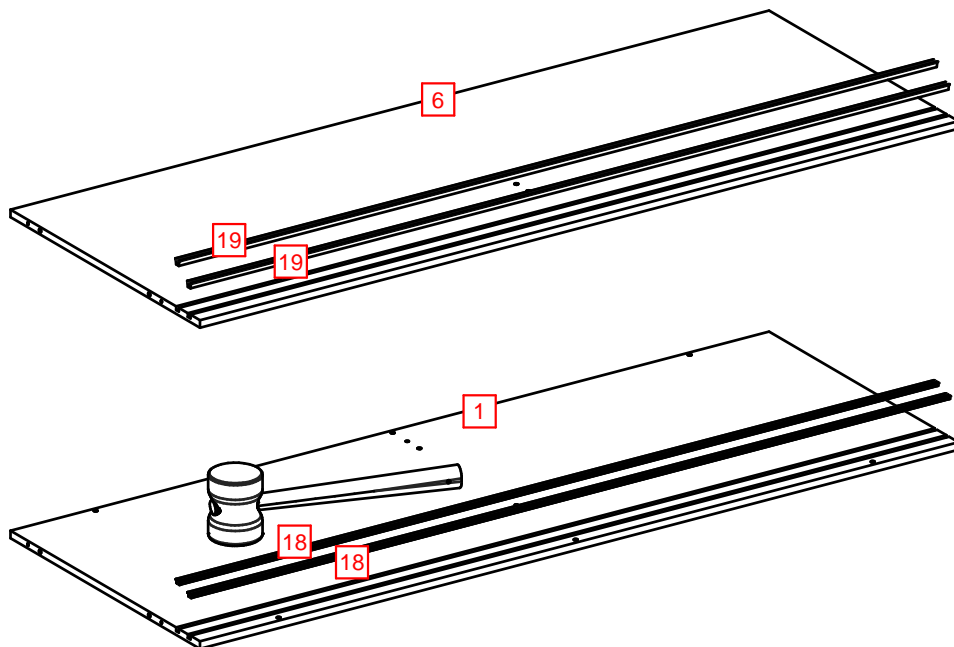

2

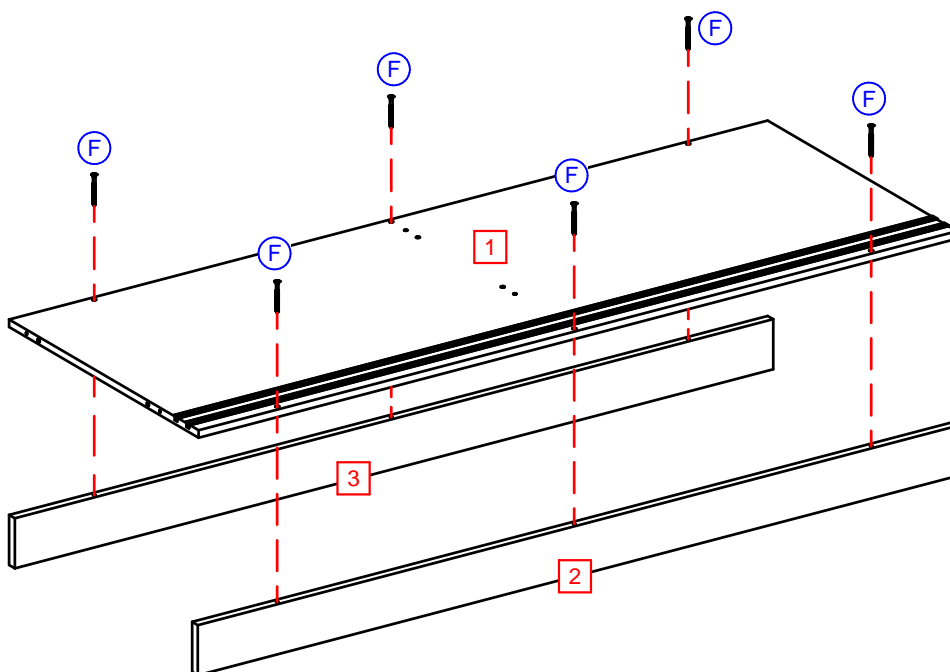

3

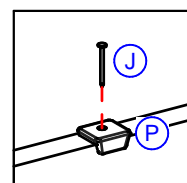
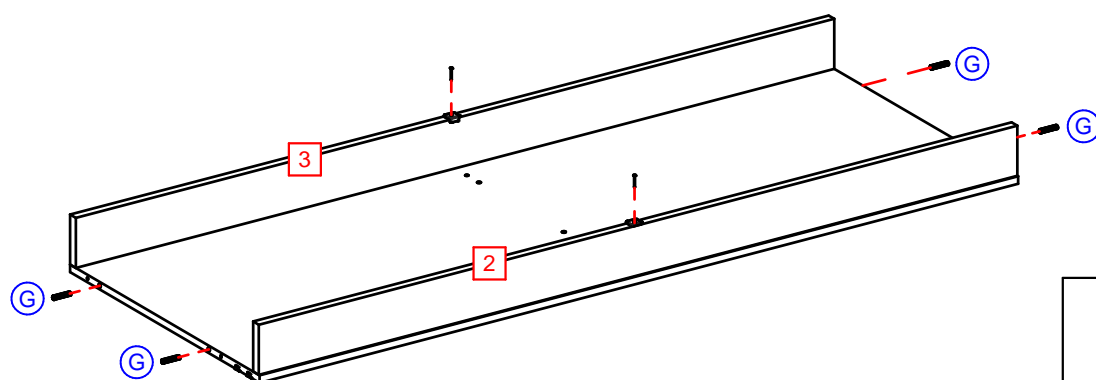

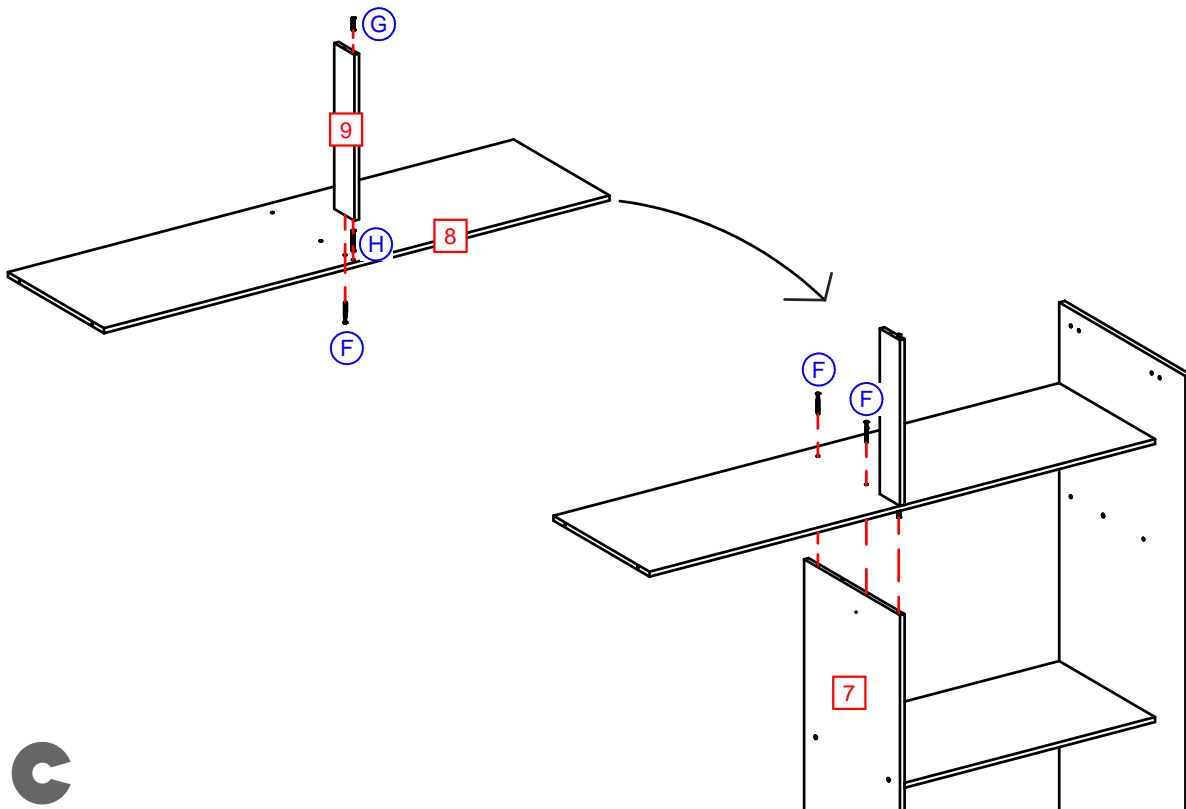
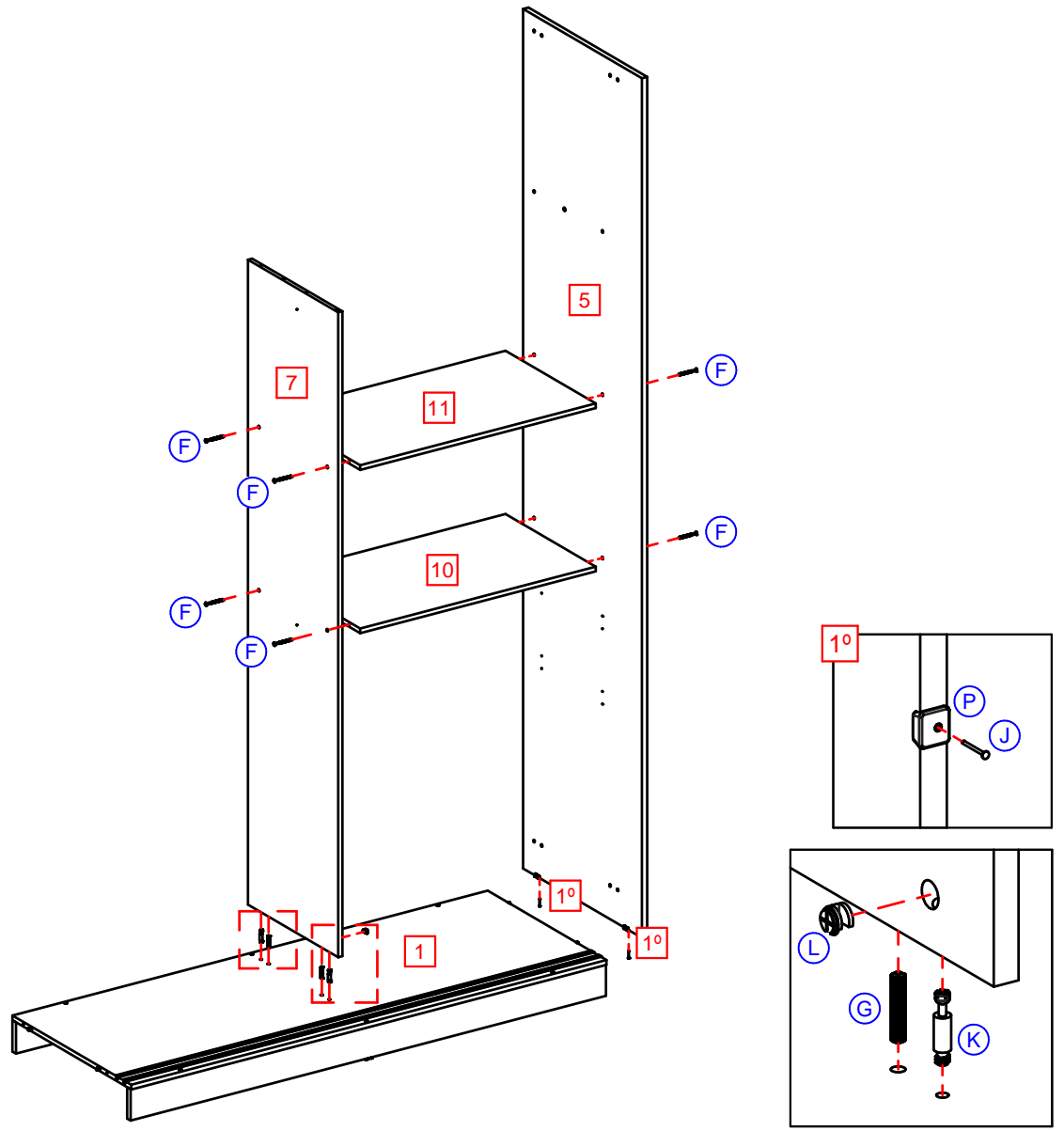

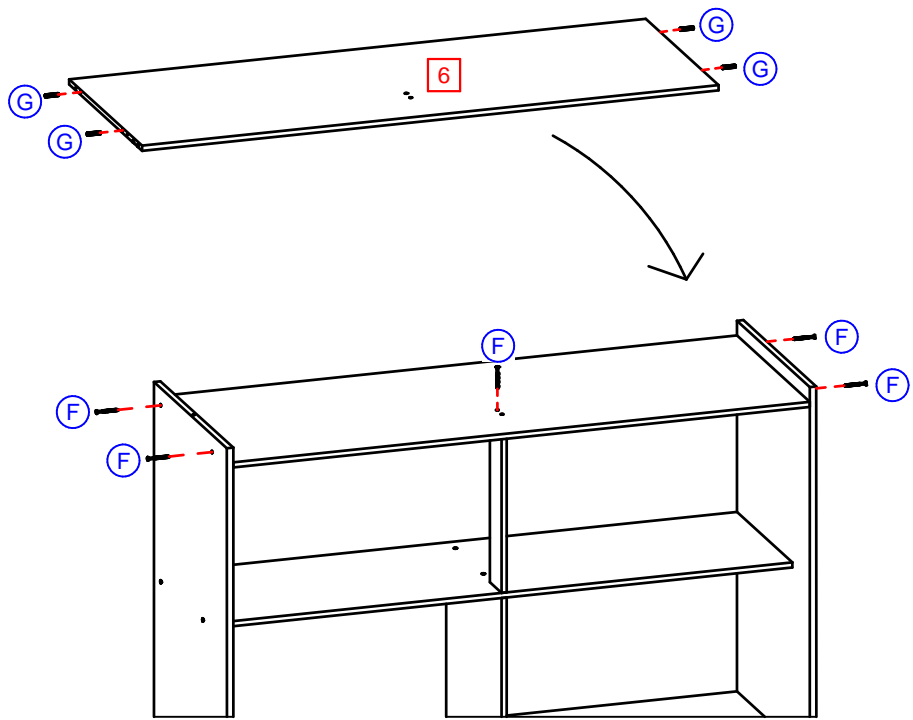
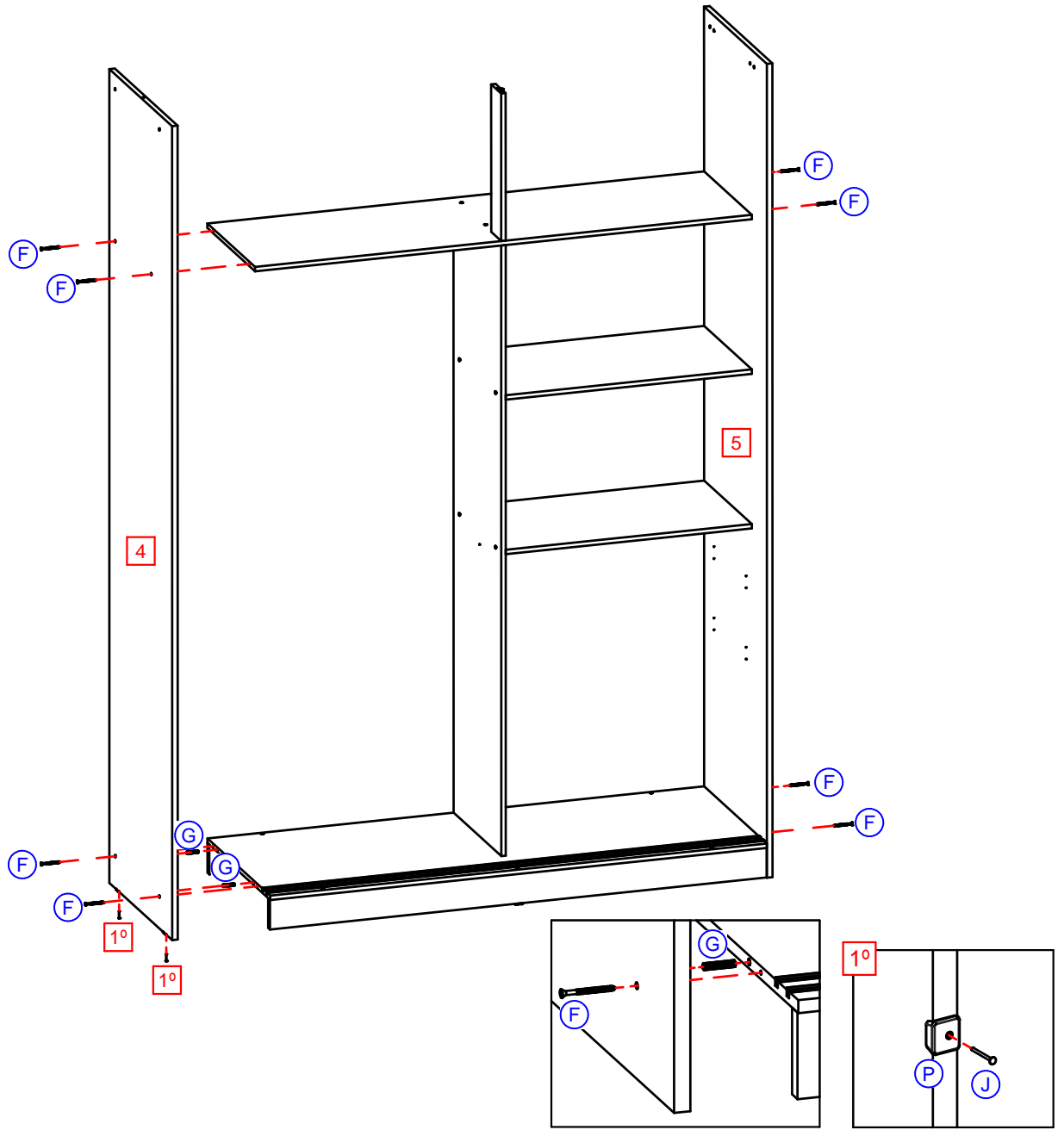

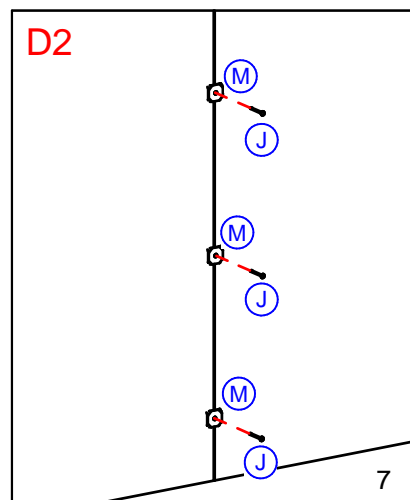
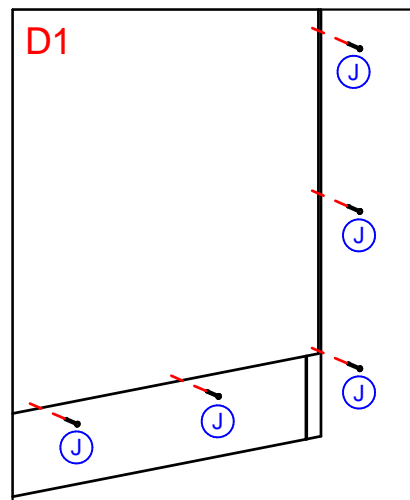
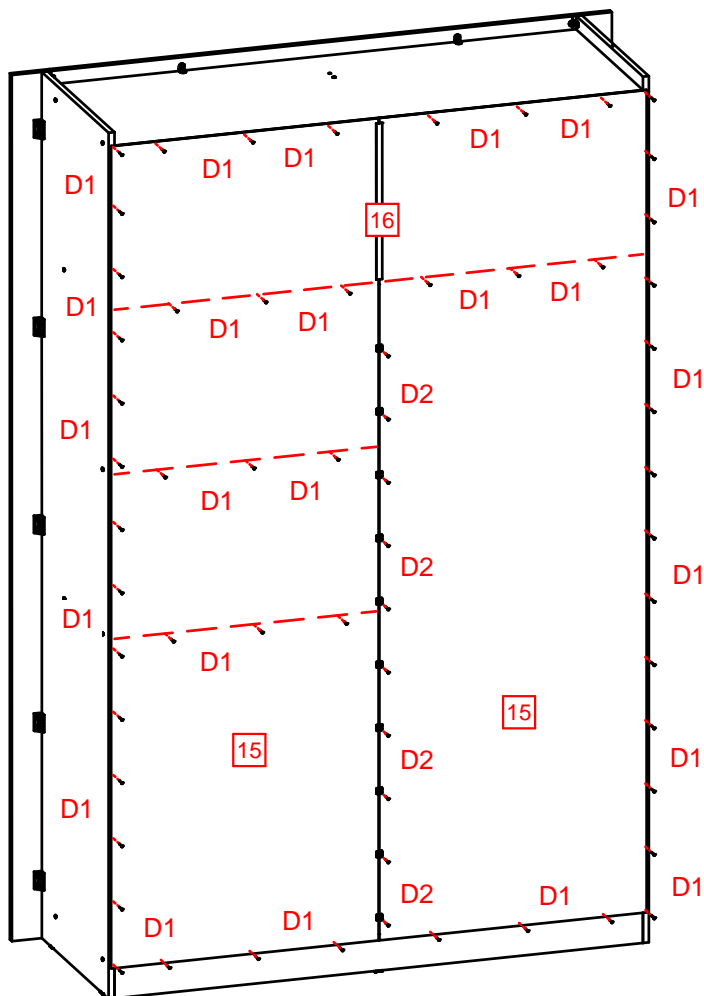
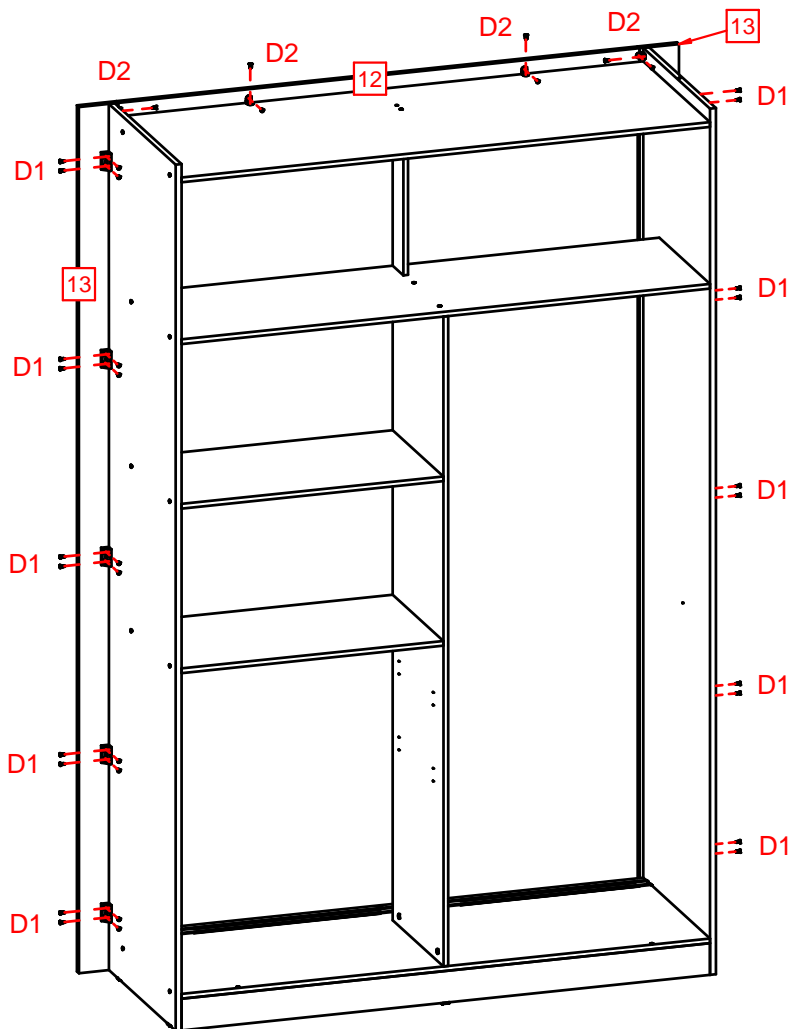
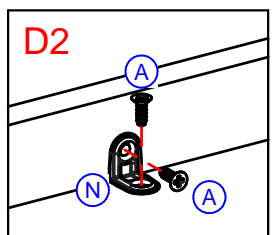
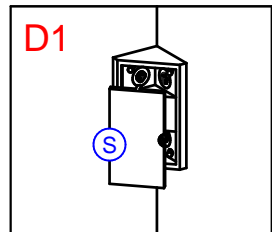
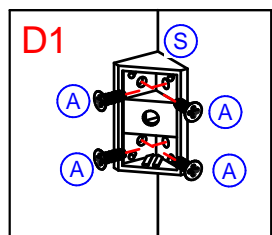

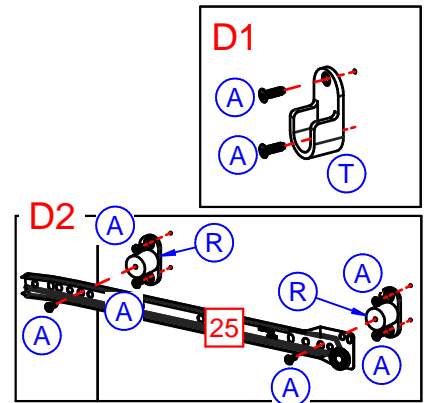
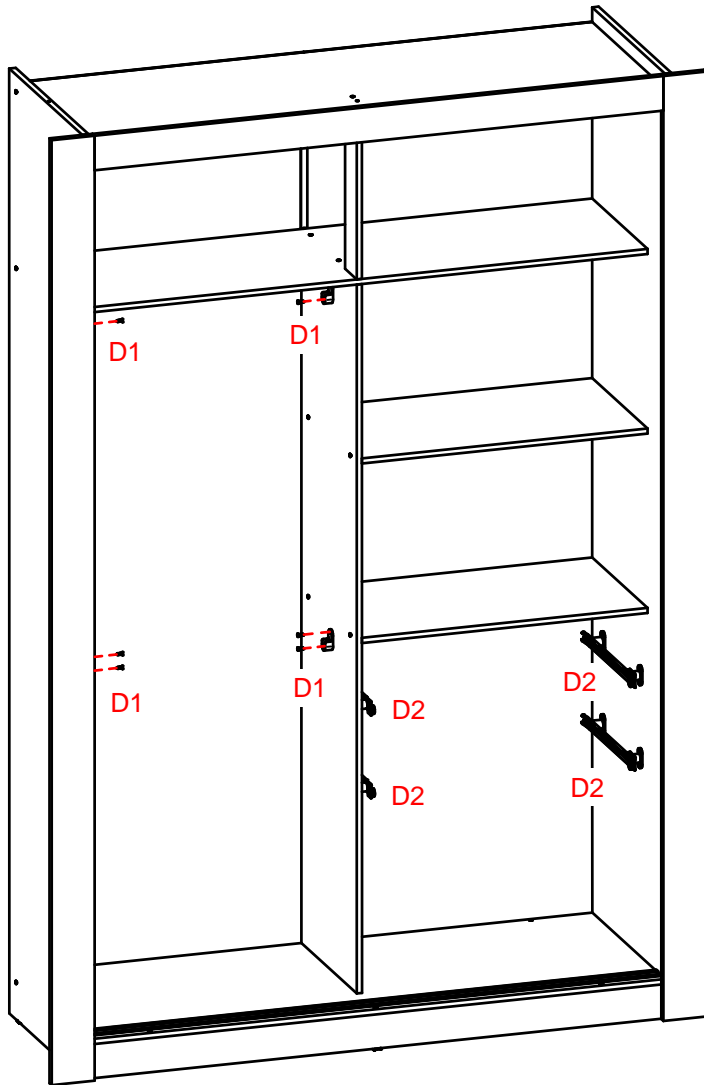

12-2X

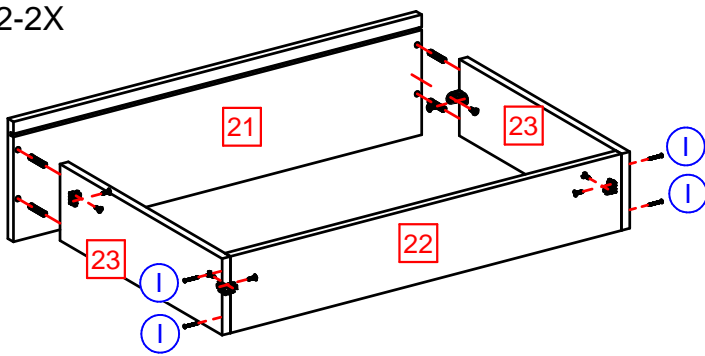

13-2X

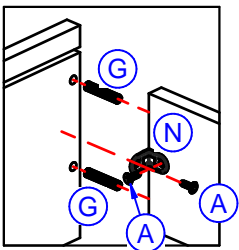
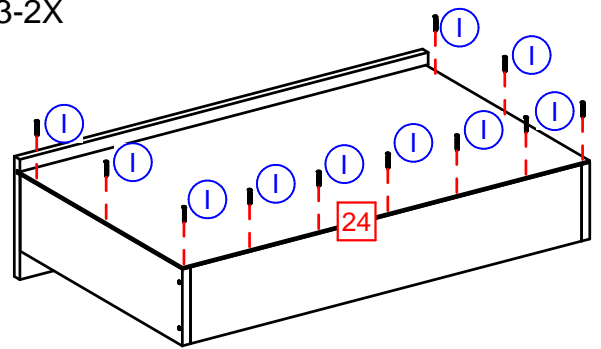

14-2X

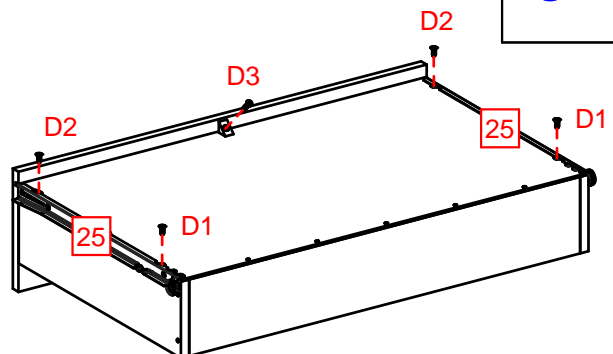
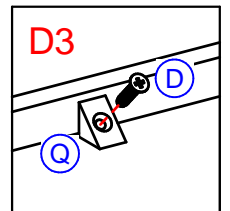
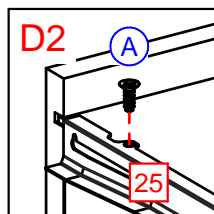
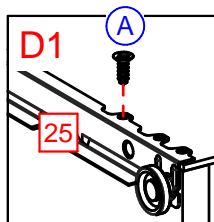

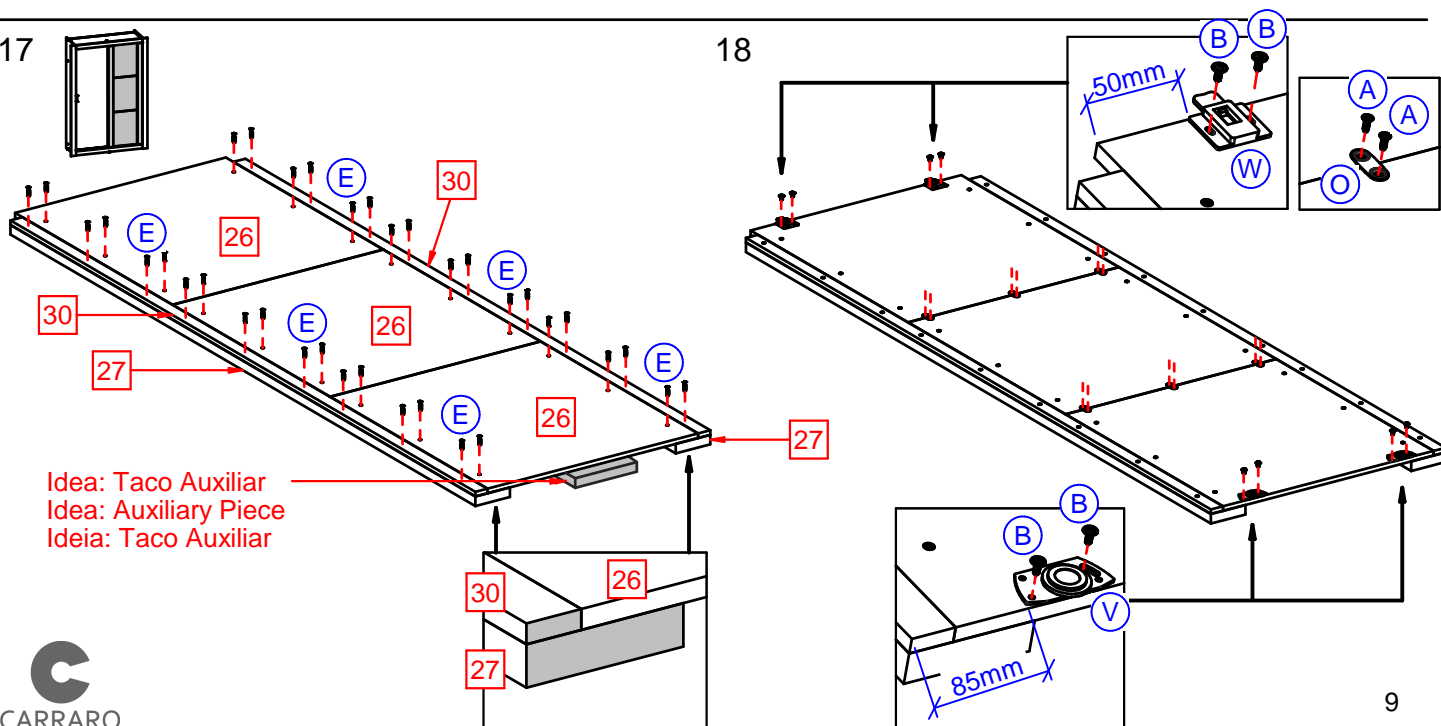
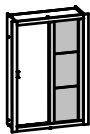
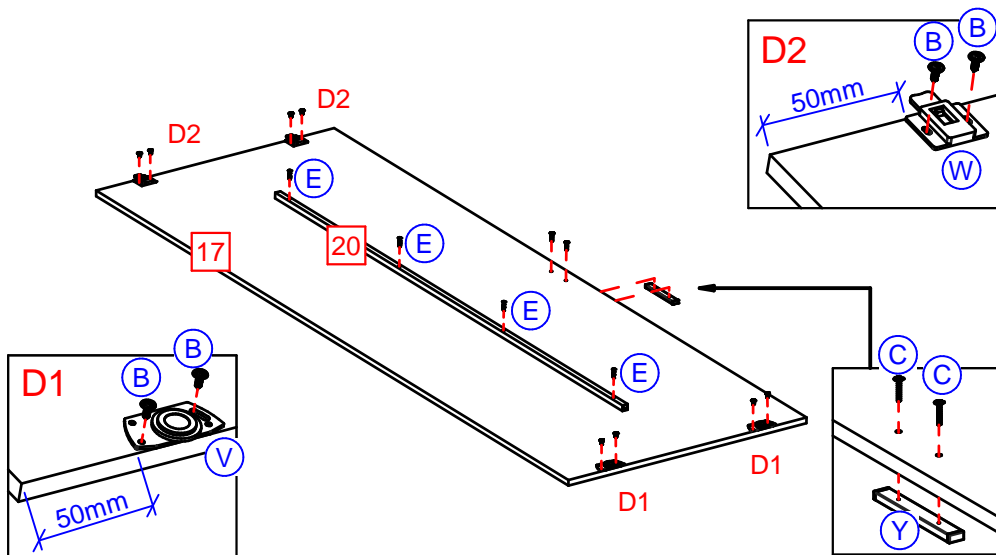
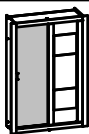
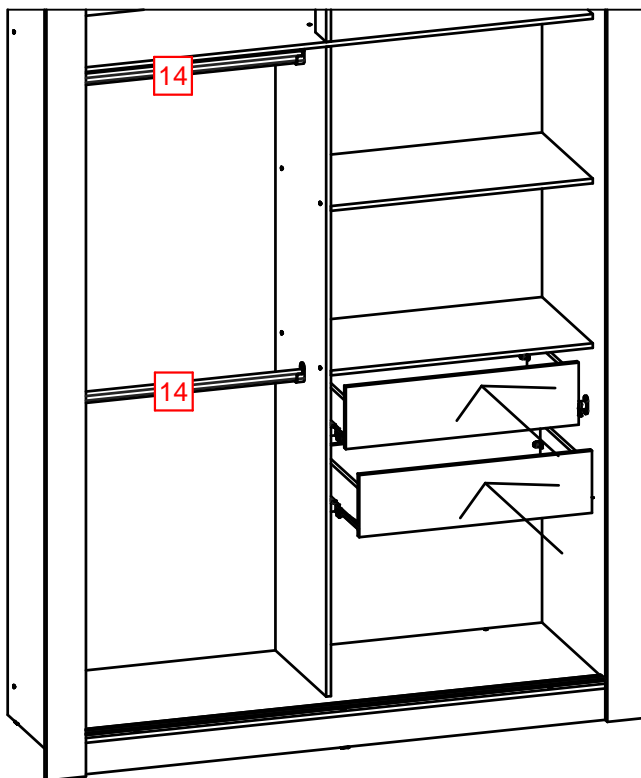

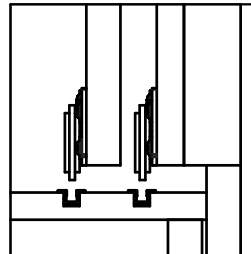
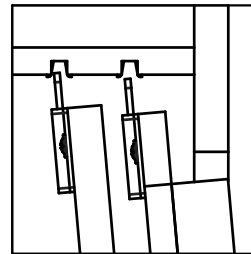
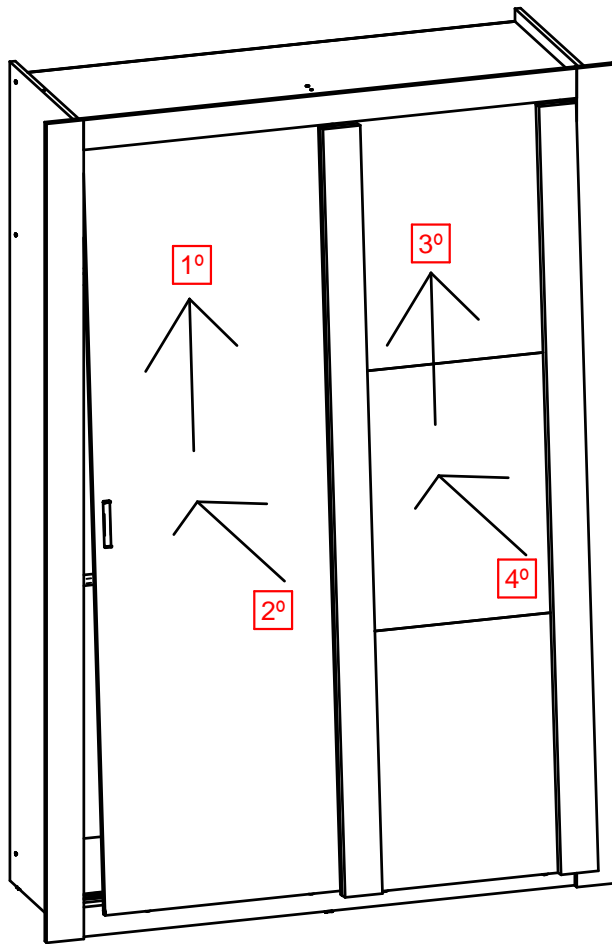

Ajuste Puertas / Doors Adjustment / Regagem Portas

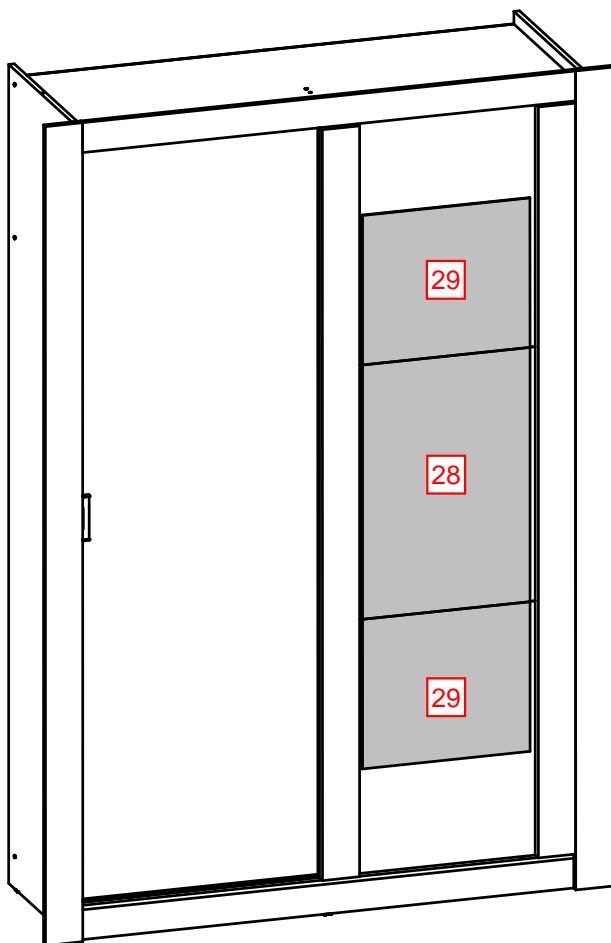
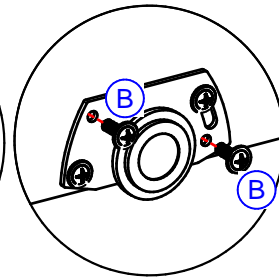
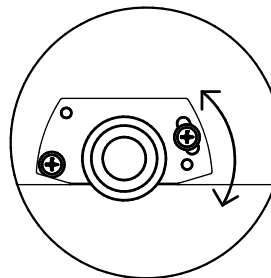

Colocación del espejo / Mirror fixation / Colocação do Espelho

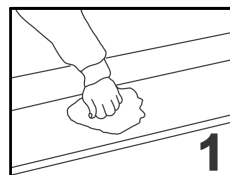

1
Limpiar la puerta con paño seco.
Clean the door with one dry cotton.
Limpar a porta com um pano seco.

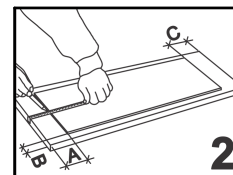

2
Marca la puerta para arreglar el espejo.
Mark the door to fix the mirror.
Marcar a porta para colocação do espelho.

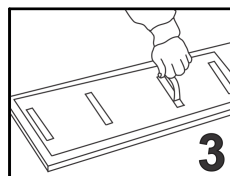

3
Sacar con cuidado la protección de la cinta dupla face.
Take off carefully the protection of double band of the face.
Tirar com cuidado a proteção da fita dupla face.

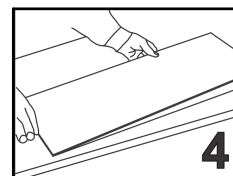

4
Poner el espejo, con cuidado, en la posición marcada.
Fix the mirror, carefully in the marked place.
Colocar o espelho, cuidadosamente, no lugar marcado.

Poner dos batientes en las puertas deslizantes, según el detalle.
Please, put two door stops on sliding doors, as detail.
Colocar dois batentes nas portas de correr, conforme detalhe.

Poner tapa agujeros adhesivos y plasticos, según el detalle.
Please, put adhesive and plastic hole covers, as per detail.
Colocar tapa furos adhesivos e plásticos, conforme detalhe.

