

HENN

Ind. e Com. de Móveis Henn
Mondai - SC - Brasil

+55 49 3674.3500

@moveishenn
www.henn.com.br

INSTRUÇÕES DE MONTAGEM

INSTRUCCIONES DE MONTAJE
ASSEMBLY INSTRUCTIONS

Aéreo 01 Porta Basculante Vidro com Nicho Connect | 01 puerto de aire de camiones de cristal con el nicho Connect | 01 air port Glass Tipper Connect with Niche

- c C59-23 - Duna
- c C59-42 - Fend
- c C59-139 - Off White

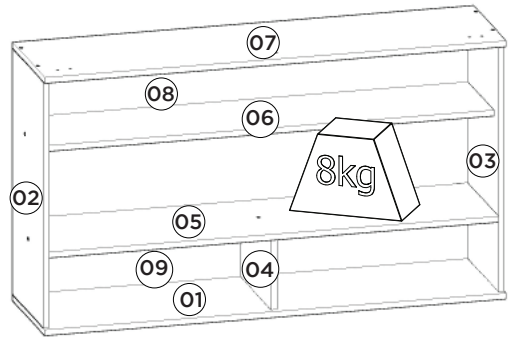
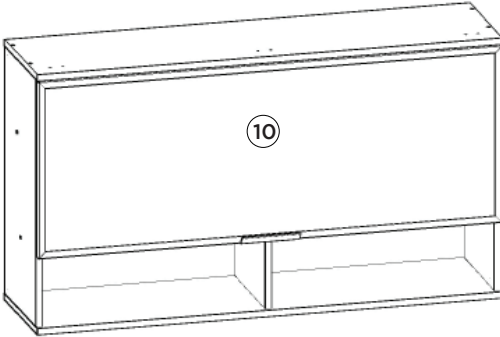

Pesos máximos recomendados com carga distribuída
Peso máximo recomendado con la carga distribuída
Recommended maximum weight with distributed load.

AVISO

Para limpeza de seu móvel, use uma flanela seca ou umedecida, e não utilize produtos químicos que possam danificar seu produto.

SISTEMA DE MONTAGEM

O sistema de montagem dos produtos, funciona de acordo com a ordem crescente dos números indicados no desenho. Ex: 01, 02, 03, 04... até a conclusão da montagem.

ASSISTÊNCIA TÉCNICA

Para solicitação de Assistência Técnica você consumidor deverá entrar em contato com o Lojista o qual você realizou a compra deste produto e solicitar a assistência técnica das peças avariadas. A garantia abrange todas as peças, partes e componentes que eventualmente venham apresentar defeito de fabricação no prazo de 03 (três) meses, contando a partir da entrega do produto ao consumidor, mediante nota fiscal de compra. Se houver qualquer alteração na estrutura do produto ou ocorrer defeito por negligência do montador/consumidor em relação a instrução de montagem e manuseio, não será fornecido assistência técnica gratuita.

ADVERTENCIA

Para limpieza de su móvil, use una flanela seca o húmeda, y no utilice productos químicos que puedan dañar su producto.

SISTEMA DE MONTAJE

El sistema de montaje de los productos funciona de acuerdo con el orden creciente de los números indicados en el dibujo. Ej.: 01, 02, 03, 04... hasta la conclusión del montaje.

ASISTENCIA TÉCNICA

Para solicitar Asistencia Técnica, el consumidor debe comunicarse con el Comercio que usted realizó la compra de este producto y solicita asistencia técnica para las partes dañadas. La garantía cubre todas las partes, piezas y componentes que eventualmente puedan presentar defecto de fabricación en el plazo de 03 (tres) meses, contados a partir de la entrega del producto al consumidor, mediante factura de compra. Si se produce algún cambio en la estructura del producto o se produce un defecto por negligencia del montador/consumidor en relación con las instrucciones de montaje y manipulación, no se prestará asistencia técnica gratuita.

NOTICE

To clean your furniture, use a dry or wet cloth, and do not use chemicals that may damage your product.

ASSEMBLY SYSTEM

The products' assembly system works according to the increasing order of the indicated numbers. For example: 01, 02, 03, 04 ... to the end of the assembly.

TECHNICAL ASSISTANCE

To request Technical Assistance, the consumer must contact the retailer from whom you purchased this product and request technical assistance for the damaged parts. The warranty covers all parts, parts and components that may eventually present a manufacturing defect within a period of 03 (three) months, counting from the delivery of the product to the consumer, by means of a purchase invoice. If there is any change in the structure of the product or defect occurs due to negligence of the assembler/consumer in relation to the assembly and handling instruction, free technical assistance will not be provided.

Requisitos para montagem Requisitos para la montaje Assembly Requirements

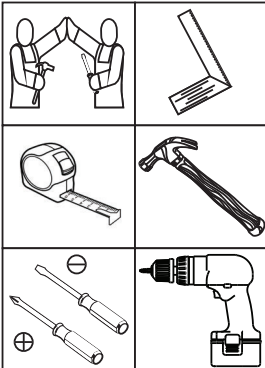

Imagens meramente ilustrativas
Imágenes meramente ilustrativas
Images for illustration only

1º

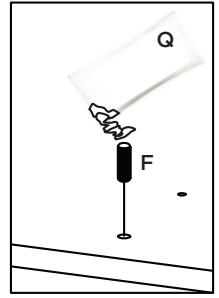
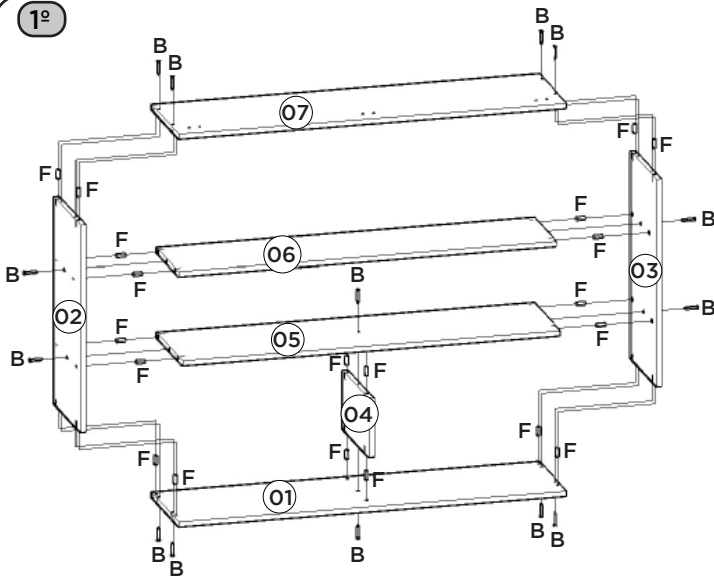

Utilizar o sachê de cola (Q) em todas as cavilhas (F) do produto.

Con el pegamento sobre (Q) en todos los pernos (F) producto.

Use the glue sachet (Q) on all the pegs (F) of the product.

2º

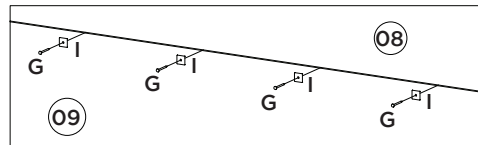
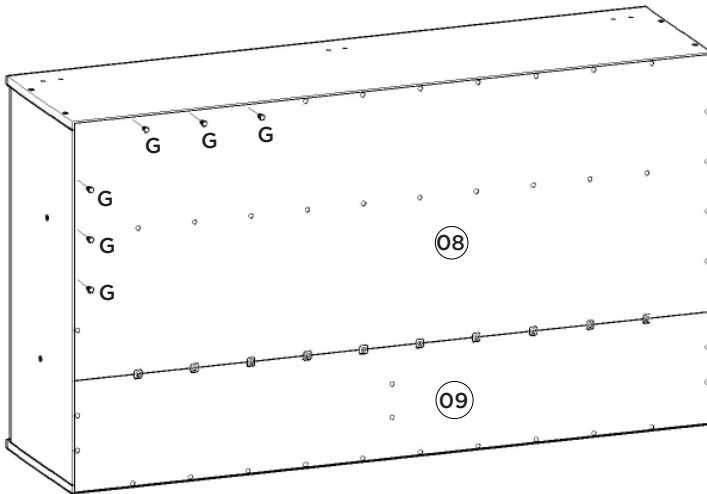

3º Regulagem do pistão sempre o mais distante possível da dobradiça. Ajuste de pistón siempre en la medida de lo posible, la bisagra.

Adjust the piston as far as possible from the hinge.

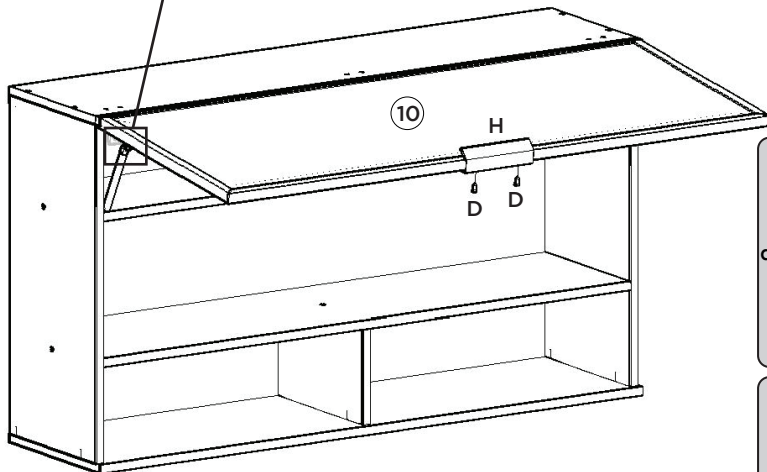

Regulagem do parafuso da dobradiça no máximo para dentro, afastando a porta do tampo, isso apenas nas duas extremidades da porta. Já na dobradiça central da porta o parafuso deverá ficar na regulagem normal (no meio).

Ajuste del tornillo de la bisagra en el máximo hacia dentro, alejando la puerta de la tapa, sólo en los dos extremos de la puerta. En la bisagra central de la puerta, el tornillo deberá quedar en la regulación normal (en el centro).

Adjusting the hinge bolt to maximum inside, pushing the door off the top, this only at both ends of the door. In the central hinge of the door the bolt should be in the normal setting (in the middle).



Video: Instalar e regular Dobradiças

Video: Instale y ajuste las bisagras

Video: Install and adjust hinges

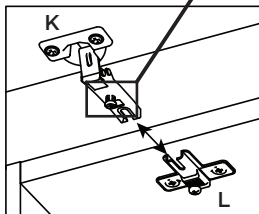
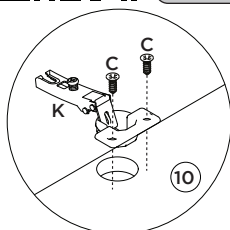
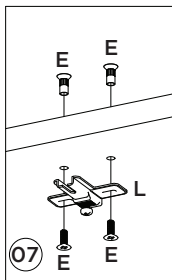

Video: Dicas para instalar o Kit Pistão à Gás





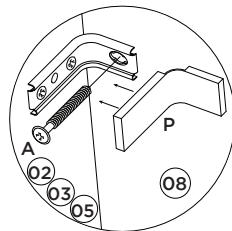
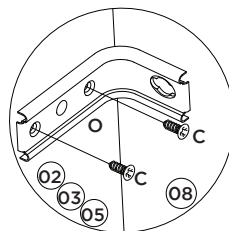
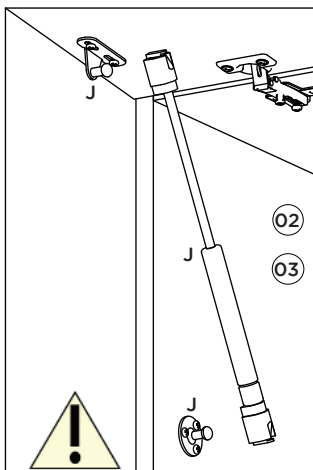
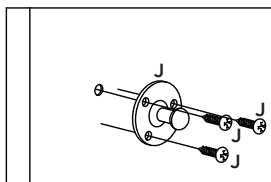
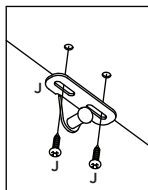





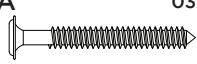

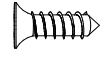



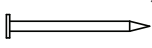

Video: Consejos para instalar el kit de pistón de gas

Video: Tips for installing the Gas Piston Kit

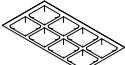
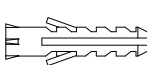

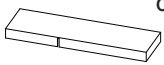

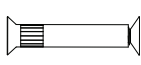
Item	Caixa Caja Box	Qtd Ctd Qty	Descrição Descripción Description	Medidas (mm) Dimensions (mm) Size (measurements) (mm)
01	1/1	01	Base Base Base	1200x310x15
02	1/1	01	Lateral esquerda Lateral izquierda Left side	645x295x15
03	1/1	01	Lateral direita Lateral derecha Right side	645x295x15
04	1/1	01	Divisória Tabique Partition	293x183x15
05	1/1	01	Base Porta Basculante Base Puerta Basculante Basculating Door Base	1168x295x15
06	1/1	01	Prateleira Estante Shelf	1168x250x15
07	1/1	01	Tampo Tapa Top	1200x310x15
08	1/1	01	Fundo Fondo Bottom	1192x466x3
09	1/1	01	Fundo Estreito Fondo Estrecho Narrow Bottom	1192x202x3
10	1/1	01	Porta de Vidro Reflecta Puerta de cristal reflectante Reflecta Glass Door	1195x458x20

Ferragens | Herrajes | Hardware

A  Parafuso 5,0x50mm FLA. Tornillo 5,0x50mm FLA. Screw 5,0x50mm FLA.	03x	B  Parafuso 3,5x40mm CHT. Tornillo 3,5x40mm CHT. Screw 3,5x40mm CHT.	14x	C  Parafuso 4,0x14mm CHT. Tornillo 4,0x14mm CHT. Screw 4,0x14mm CHT.	12x	D  Parafuso 3,5x12mm CHT. Tornillo 3,5x12mm CHT. Screw 3,5x12mm CHT.	02x	E  Parafuso União 15mm Tornillo Unión 15mm Union Screw 15mm	06x
F  Cavilha 8x25mm Cinta 8x25mm Dowel 8x25mm	20x	G  Prego 10x10mm Clavo 10x10mm Nail 10x10mm	54x	H  Perfil Puxador 2015 - 150mm Perfil de Tirador 2015 - 150mm Profile Handle 2015 - 150mm	01x	I  Fixador de fundos Fijador de fondos Bottom fixer	10x	J  Kit Pistão a Gás 60N Kit Pistón a Gas 60N 60N Gas Piston Kit	02x
K  Dobradiça metal 35mm Alta Bisagras metálicas 35mm Alta Metal hinge 35mm High	03x	L  Calço metal Super Alto 8mm Calzado metálico Super Alto 8mm Super 8mm metal chock	03x	M  Batente PVC para Porta Parada de PVC para Puerta PVC Door Stop	03x	N  Bucha plástica 8mm Bucha de plástico 8mm 8mm plastic bushing	03x	O  Suporte de fixação Soporte de fijación Mounting bracket	03x
P  Proteção para cantoneira Ángulo de protección Protection angle	03x	Q  Sachê de cola Bolsa de pegamento Glue bag	01x	R  Adesivo tapa parafuso 10mm Adhesivo tapón de tornillo 10mm Bolt cover adhesive 10mm	14x	S  Parafuso União 30mm Tornillo Unión 30mm Union Screw 30mm	04x	T  Giz de correção Tiza de corrección Chalk of correction	02x
U  Etiqueta resinada Henn Etiqueta resinada Henn Henn resin label	01x								

 O parafuso (S) deve ser usada somente quando este módulo for acoplado a outro módulo componível Henn.

 El tornillo (S) se debe utilizar sólo cuando el módulo está conectado a otro módulo componible Henn.

 The screw (S) should be used only when this module is attached to another Henn modular module.

RECOMENDAÇÃO
Para fixar o móvel na parede usar o suporte de fixação (O), o parafuso 4,0x14mm CHT (C), a Bucha 8mm (N) e o parafuso 5,0x50mm FLA (A).

RECOMENDACIÓN
Para conectar el móvil a la pared con el soporte (O), tornillo 4,0x14mm CHT (C), el casquillo de 8 mm (N) y el 5,0 x50mm tornillo FLA (A).

RECOMENDATION
To fix the furniture to the wall use the fixing bracket (O), the 4.0x14mm CHT (C) screw, the 8mm bushing (N) and the 5.0x50mm FLA screw (A).