

CÓD	DESCRIÇÃO	DIMENSÕES	QTD
5778	LATERAL DIREITA	445X2300X12	01
5779	LATERAL ESQUERDA	445X2300X12	01
5780	LATERAL INTERNA DIREITA	445X1768X12	01
5782	BASE INFERIOR	445X2277X12	01
5783	BASE DO MALEIRO	445X2277X12	01
5784	BASE SUPERIOR	445X2277X12	01
5785	TAMPO	445X751X12	02
5786	PRATELEIRA	350X751X12	02
5787	PRATELEIRA MENOR	250X751X12	01
5788	BATENTE	80X350X12	02
5789	DISTANCIADOR	55X366X15	08
5790	RODAPÉ	80X2277X15	01

CÓD	DESCRIÇÃO	DIMENSÕES	QTD
5791	RODAPÉ TRASEIRO	80X2277X15	01
5792	TRAVAMENTO DO RODAPÉ	80X414X12	02
5793	MOLDURA	70X2301X15	01
5794	FRENTE DE GAVETA	169X651X12	04
5795	LATERAL DIREITA DE GAVETA	130X350X12	04
5796	LATERAL ESQUERDA DE GAVETA	130X350X12	04
5797	CONTRA FUNDO	120X591X12	04
5798	FUNDO DE GAVETA	350X601X03	04
5799	PORTA	378X2150X15	04
5800	PORTA CENTRAL	378X2150X15	02
5801	FUNDO TRASEIRO	428X2297X03	05

accessories accesorios accessoires acessórios

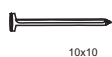

A129 (X120)



A608 (X03)



A121 (X16)



A73 (X24)



A066 (X70)



A92 (X01)



A607 (X04)



A114 (X40)



A062 (X60)



A371 (X24)



A82 (X06)



A365 (X04)



A054 (X50)



A368 (X24)



A94 (X06)

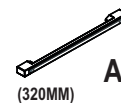

A593 (X06)



A374 (X96)



A122 (X07)

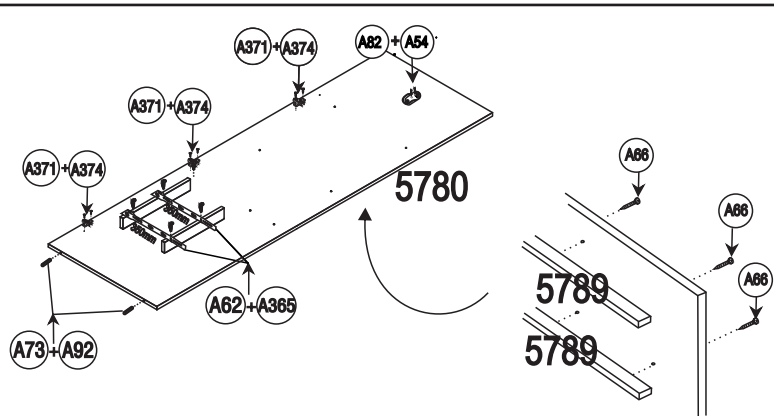
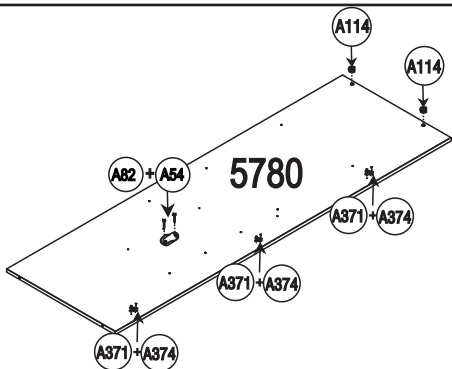
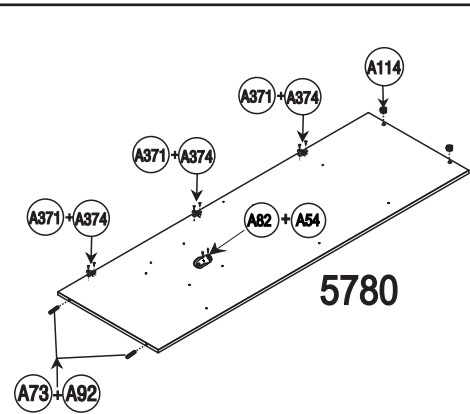
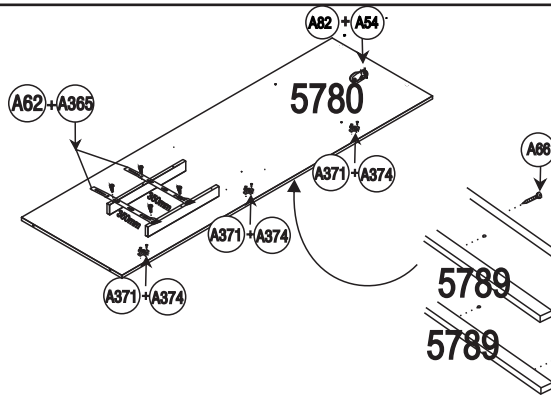
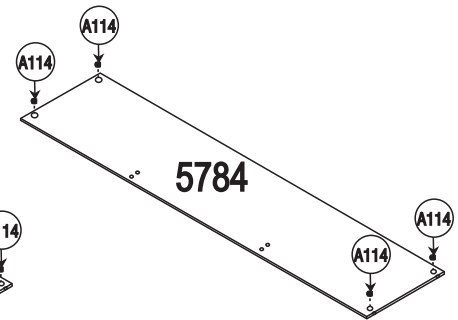
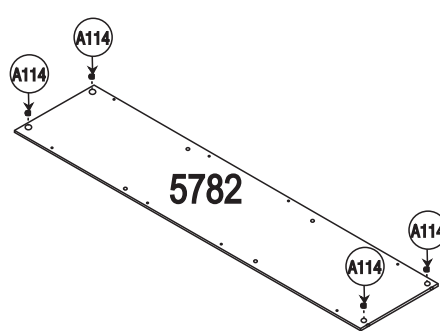
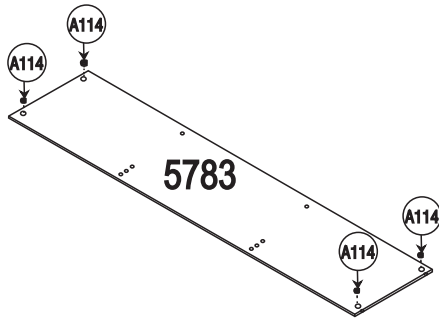
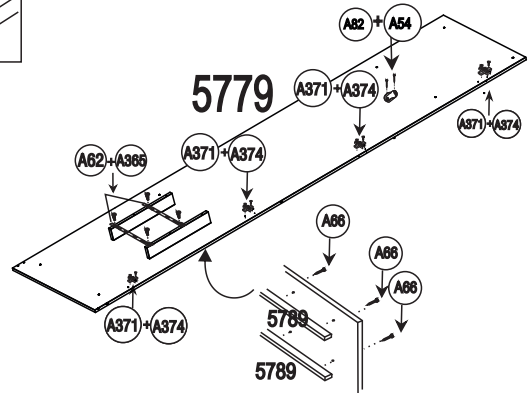
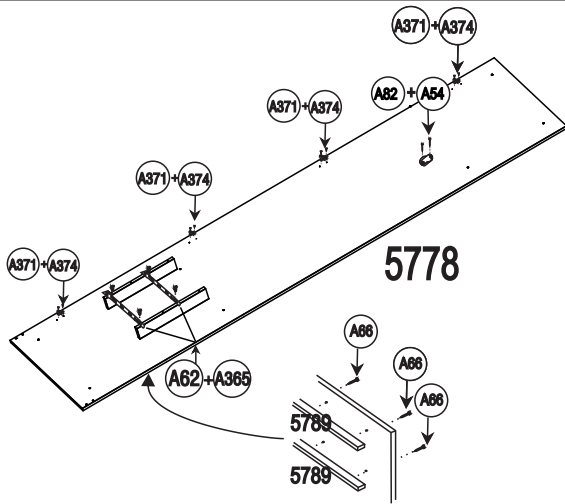

(A066 - Parafuso 4,0x40)



(A054 - Parafuso 3,5x12)



(A092 - Cola)



(A371 - Calço 7 - para dobradiça)



(A114 - Porca cilíndrica)



(A062 - Parafuso 3,5x25)



(A374 - Parafuso 3,5x12)



(A073 - cavilha 6,0x30)











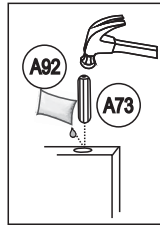
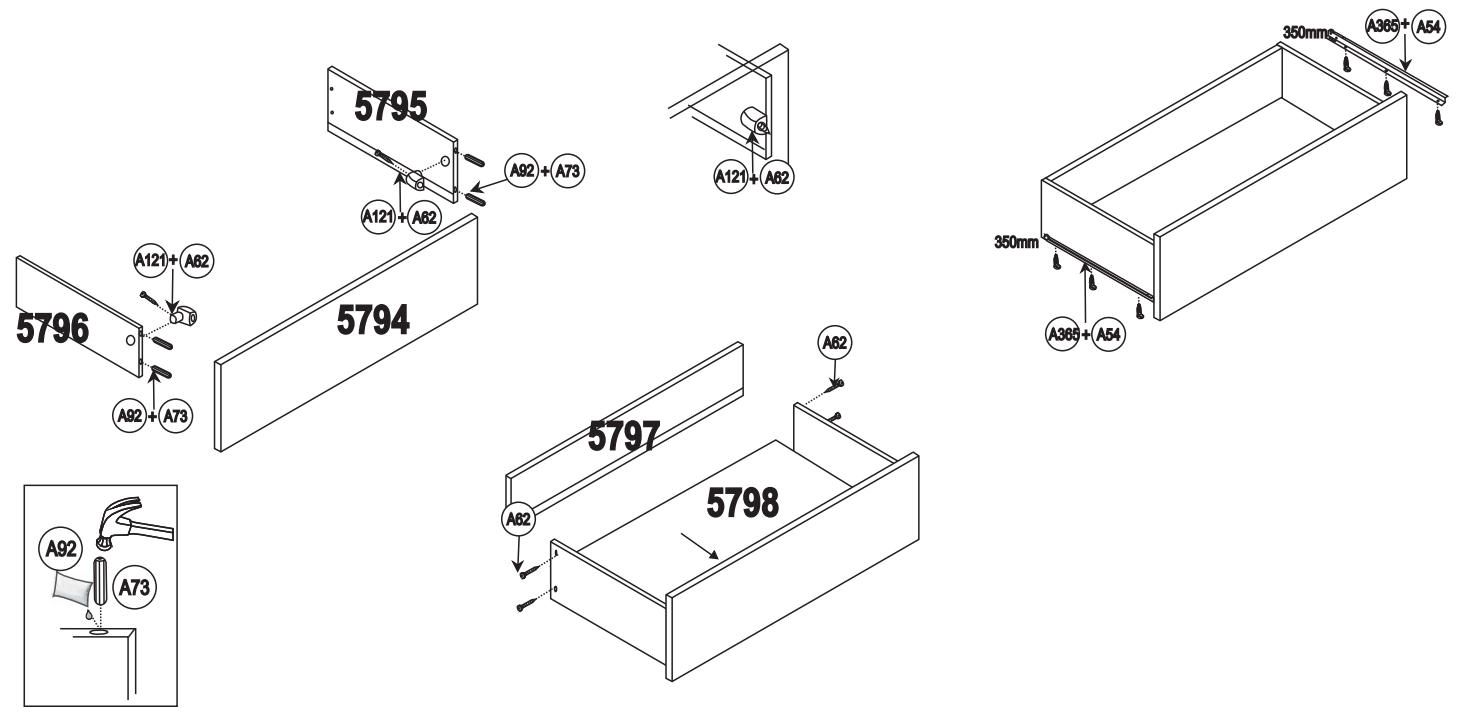
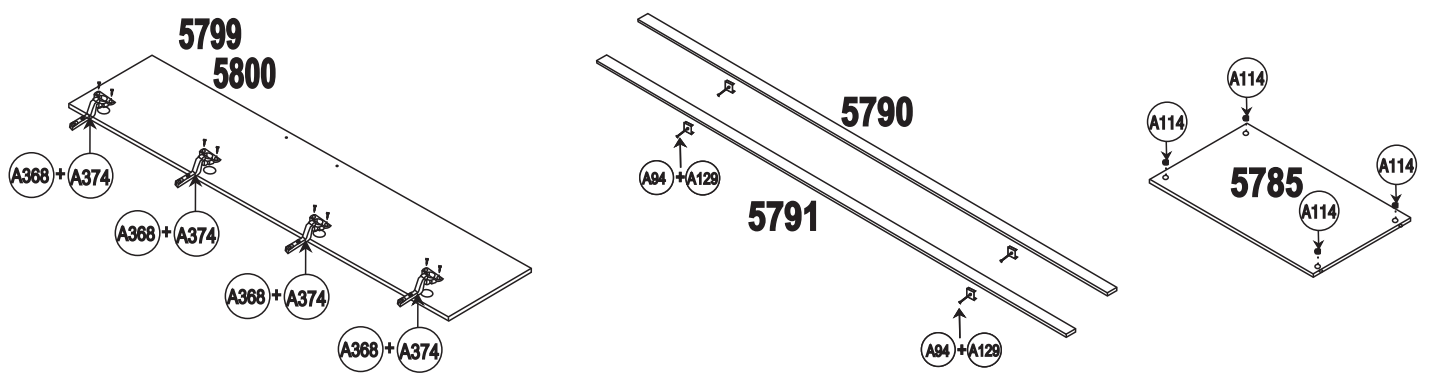
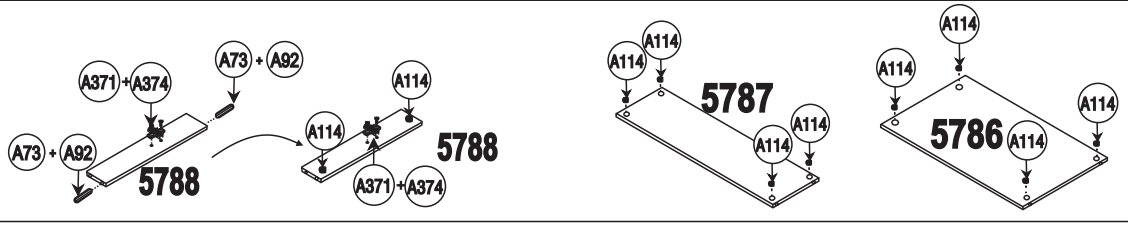
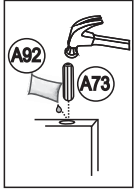

(A365 - Corrediça - 350 mm)

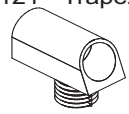

(A82 - Suporte cabideiro)





- | | | | | |
|-----------------------------------------------------------------------------------------------------------------|----------------------------------------------------------------------------------------------------------------|--------------------------------------------------------------------------------------------------------|-------------------------------------------------------------------------------------------------------------------|-------------------------------------------------------------------------------------------------------------------------------|
| (A054 - Parafuso 3,5x12)
 | (A121 - Trapezio)
 | (A092 - Cola)
 | (A114 - Porca cilíndrica)
 | (A365 - Corredieça Metálica- 350 mm)
 |
| (A062 - Parafuso 3,5x25)
 | (A073 - cavilha 6,0x30)
 | (A094 - Sapata)
 | (A368 - Dobradiça Ø 26)
 | (A374 - Parafuso 3,5x12 CP)
 |

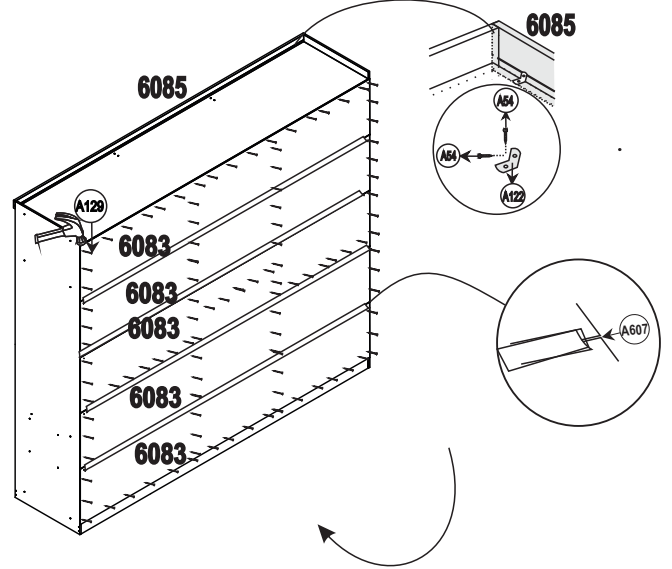
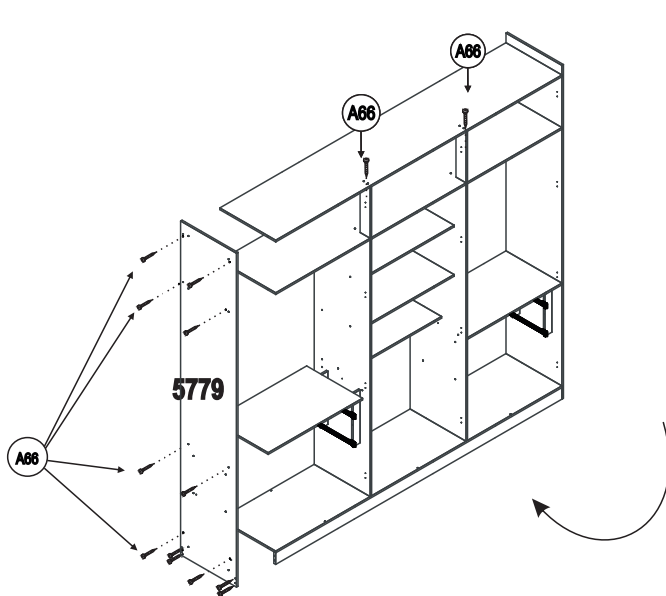
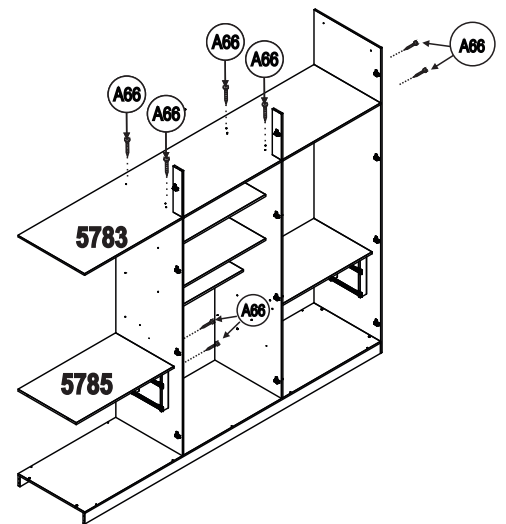
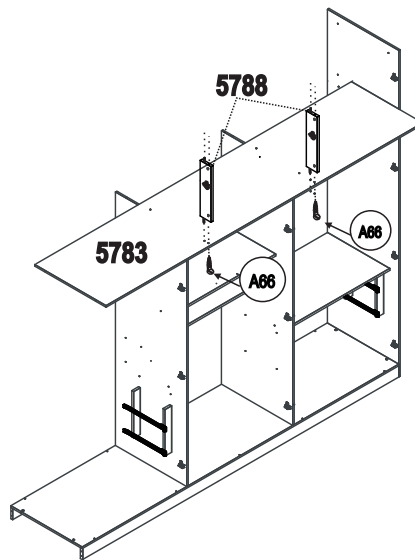
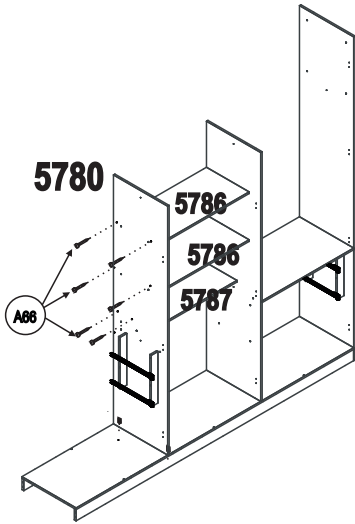
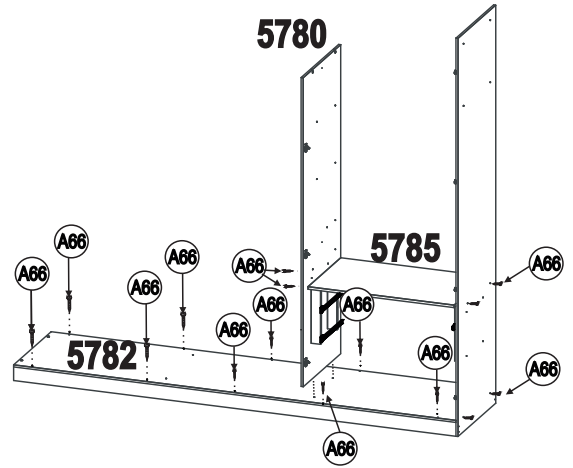
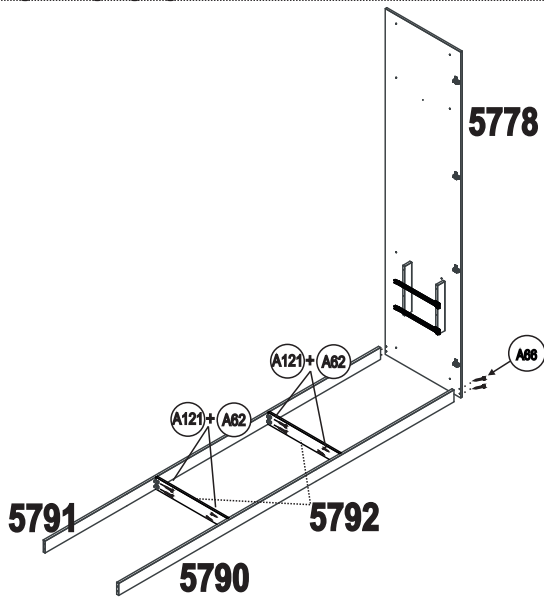

(A062 - Parafuso 3,5x25)

(A066 - Parafuso 4,0x40)

(A129 - Prego 10x10)

(A607 - Perfil H - 2.279 mm)

(A122 - Cantoneira Metálica)



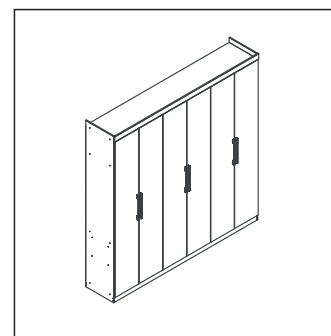
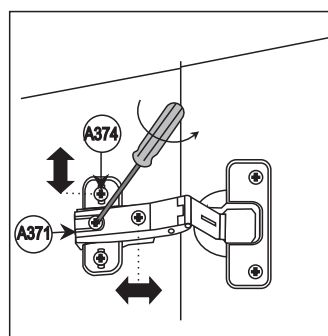
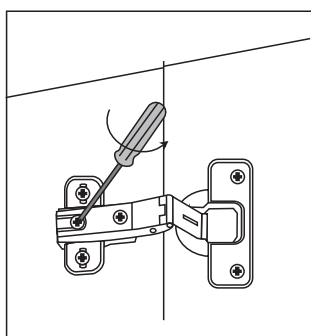
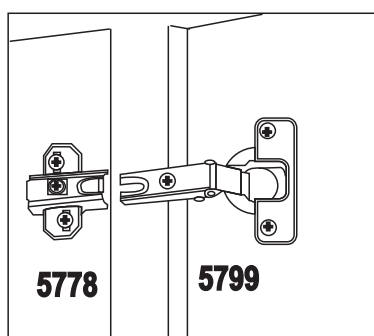
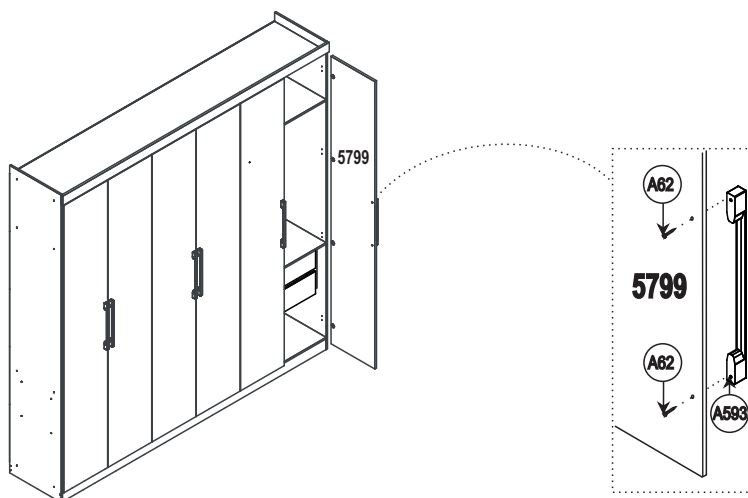
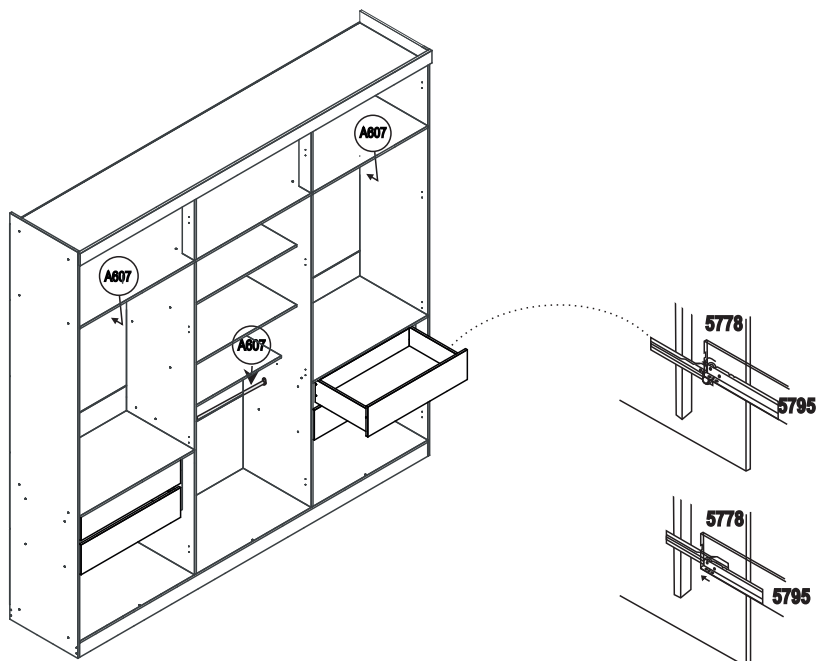

- In order to adjust correctly the door, please observe the picture. In order that the doors stay at the same level the adjustment should be done through the screw A374 from A371 accessory.
- Para ajustar correctamente la puerta, por favor observe la imagen. Para la permanencia de puertas en el mismo nivel el ajuste debería ser hecho por el tornillo A374 del accesorio de A371.
- Pour ajuster correctement la porte, observez s'il vous plaît l'image. Afin que les portes soit au même niveau l'ajustement devrait être fait par la vis A374 de l'accessoire A371.
- Para o ajuste ideal das portas, observe a foto em destaque. Para que as portas fiquem no mesmo nível, o ajuste deverá ser feito através do parafuso A374 do acessório A371.

peça peça pièce pieza

- Em caso de problemas técnicos com o móvel, favor informar o número de lote e data de fabricação, identificados nas bordas de alguns componentes dos móveis, para o rastreamento interno do produto e solução do problema.
- If technical problems happened, please find the lot number and manufacturing date, identified on borders of some furniture's pieces, to internal tracking and problem's solution.
- Dans le cas de problèmes technique avec le meuble, informer le numéro de lot et la date de fabrication, identifie dans le cadre de quelque composant des meubles, permettant a nous identifier le produit et le problème.
- En caso de problemas técnicos, por favor informe el N° del lote y la fecha de fabricación. Identificada en el borde de algunas de las partes del mueble para la identificación interna del producto y la solución del problema.

