

Item	Caixa Box	Qty	Descrição Descripción	Medidas (mm) Dimensions (mm) Size (measurements) (mm)	Código das Peças Código de las piezas Parts Code
01	2/4	01	Rodapé Frontal frente pie de página Front Footer	2589x73x15	03271413
02	2/4	02	Travessa do rodapé Carril pie Baseboard crosspiece	464x73x15	03301416
03	1/4	01	Rodapé Traseiro Pie de página trasera Rear Footer	2589x73x15	03271414
04	2/4	01	Base Base Base	2589x500x15	03293298
05	1/4	01	Lateral esquerda Lateral izquierda Left side	2250x500x15	03153380
06	3/4	01	Divisão esquerda División izquierda Left Division	1684x420x15	03061502
07=09=13	3/4	01	Prateleira Estante Shelf	853x400x15	03221397
08	3/4	01	Divisão direita División derecha Right Division	1684x420x15	03061501
09=07=13	3/4	01	Prateleira Estante Shelf	853x400x15	03221397
10	2/4	02	Ripa do maleiro Portaequipajes de ripa Lath of the closet top shelf	414x70x15	03250677
11	1/4	01	Chão do maleiro Piso del portaequipajes Floor of the closet top shelf	2589x420x15	03293299
12	1/4	01	Lateral direita Lateral derecha Right side	2250x500x15	03153379
13=07=09	3/4	03	Prateleira Estante Shelf	853x400x15	03221397
14	2/4	01	Tampo Superior Tapa Superior Top Panel	2589x500x15	03293300
15	1/4	01	Fundo Superior Fondo Superior Top Bottom	2611x436x3	03111662
16	2/4 e 3/4	06	Fundo Fondo Bottom	1706x432x3	03111661
17	2/4	01	Moldura Superior Marco superior frame Superior	2693x73x15	03161397
18	2/4	02	Moldura Lateral Marco lateral Lateral Frame	2177x73x15	03161396
19	2/4	02	Ripa Lateral Ripa lateral Lateral Ripa	501x54x25	03250678
20	1/4	02	Painel Central Lateral Panel Central Lateral Lateral Central Panel	877x500x12	03170793
21=24	2/4	04	Aplique Aplique Apply	877x31x3	03010301
22=25	4/4	04	Painel Inferior Superior Panel Inferior Superior Top Bottom Panel	877x783x12	03170794
23	1/4	01	Painel Central Panel central Central Panel	877x500x12	03170792
24=21	2/4	02	Aplique Aplique Apply	877x31x3	03010301
25=22	4/4	02	Painel Inferior Superior Panel Inferior Superior Top Bottom Panel	877x783x12	03170794
26	3/4	03	Frente de gaveta Frente de cajón Front of drawer	795x145x12	03131283
27	3/4	06	Lado de gaveta Lado del cajón Side of drawer	350x110x12	03140621
28	3/4	03	Fundo de gaveta recortado Fondo de cajón recortado Drawer bottom trimmed	765x361x3	03120552
29	3/4	03	Ripa de trás Malla detrás Rear lath	778x110x12	03240730



Ind. e Com. de Móveis Henn
Mondai - SC - Brasil

+55 49 3674.3500

@moveishenn
www.henn.com.br

INSTRUÇÕES DE MONTAGEM

INSTRUCCIONES DE MONTAJE
ASSEMBLY INSTRUCTIONS

ROUPEIRO AMARO 03 PORTAS DESLIZANTES ARMARIO AMARO 03 PUERTAS DESLIZANTES | AMARO 03 WARDROBE SLIDING DOORS D202-05 BRANCO HP | D202-94 RÚSTICO | D202-101 CAFÉ

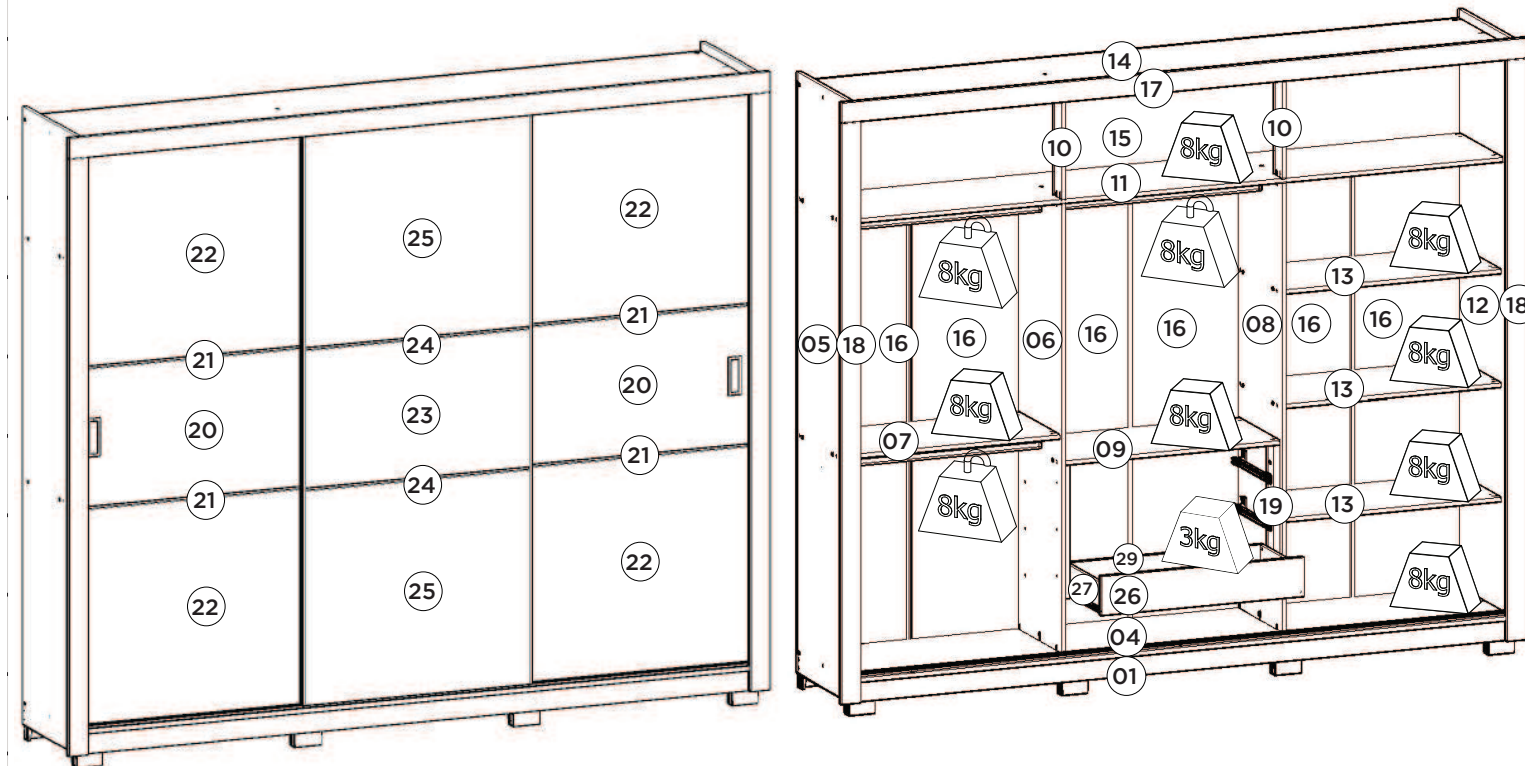

Pesos máximos recomendados com carga distribuída
Peso máximo recomendado con la carga distribuida
Recommended maximum weights with evenly distributed.

Requisitos para montagem Requisitor para la montaje Assembly Requirements

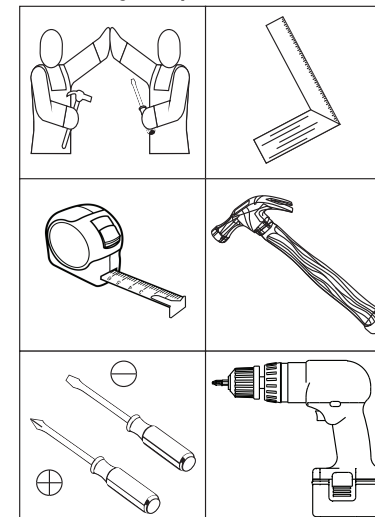

Imagens meramente ilustrativas
Imágenes meramente ilustrativas
Images for illustration only

AVISO

Para limpeza de seu móvel, use uma flanela seca ou umedecida, e não utilize produtos químicos que possam danificar seu produto.

SISTEMA DE MONTAGEM

O sistema de montagem dos produtos, funciona de acordo com a ordem crescente dos números indicados no desenho. Ex: 01, 02, 03, 04... até a conclusão da montagem.

ADVERTENCIA

Para limpieza de su móvil, use una flanela seca o húmeda, y no utilice productos químicos que puedan dañar su producto.

SISTEMA DE MONTAJE

El sistema de montaje de los productos funciona de acuerdo con el orden creciente de los números indicados en el dibujo. Ej.: 01, 02, 03, 04... hasta la conclusión del montaje.

NOTICE

To clean your furniture, use a dry or wet cloth, and do not use chemicals that may damage your product.

ASSEMBLY SYSTEM

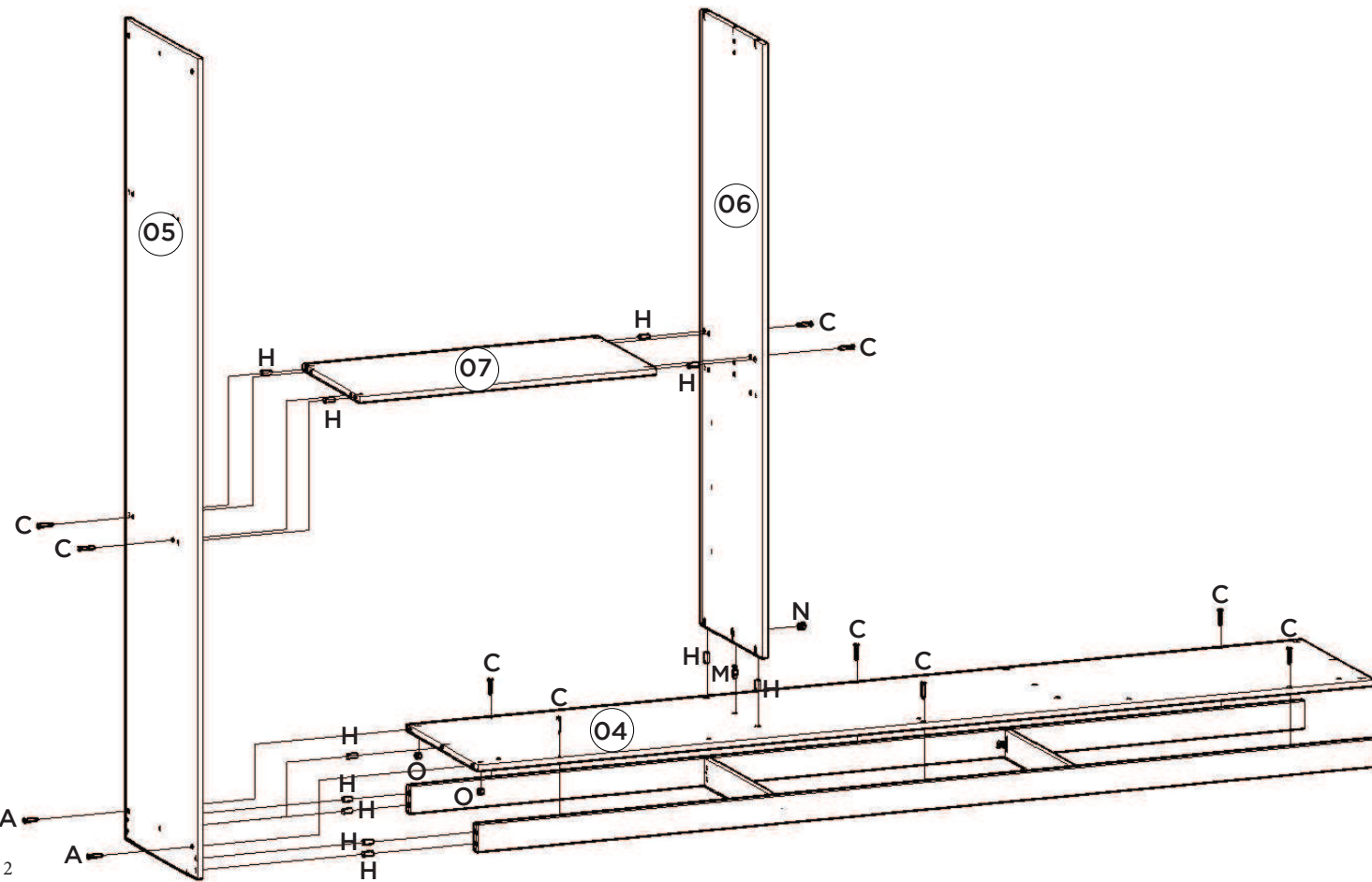
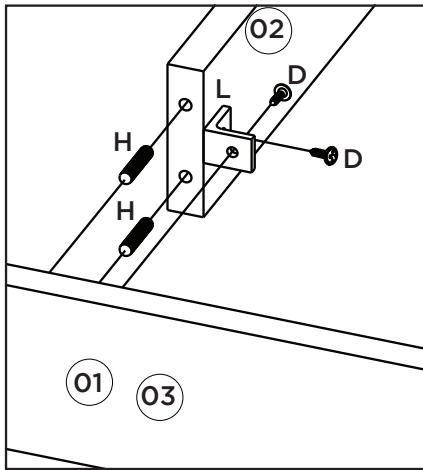
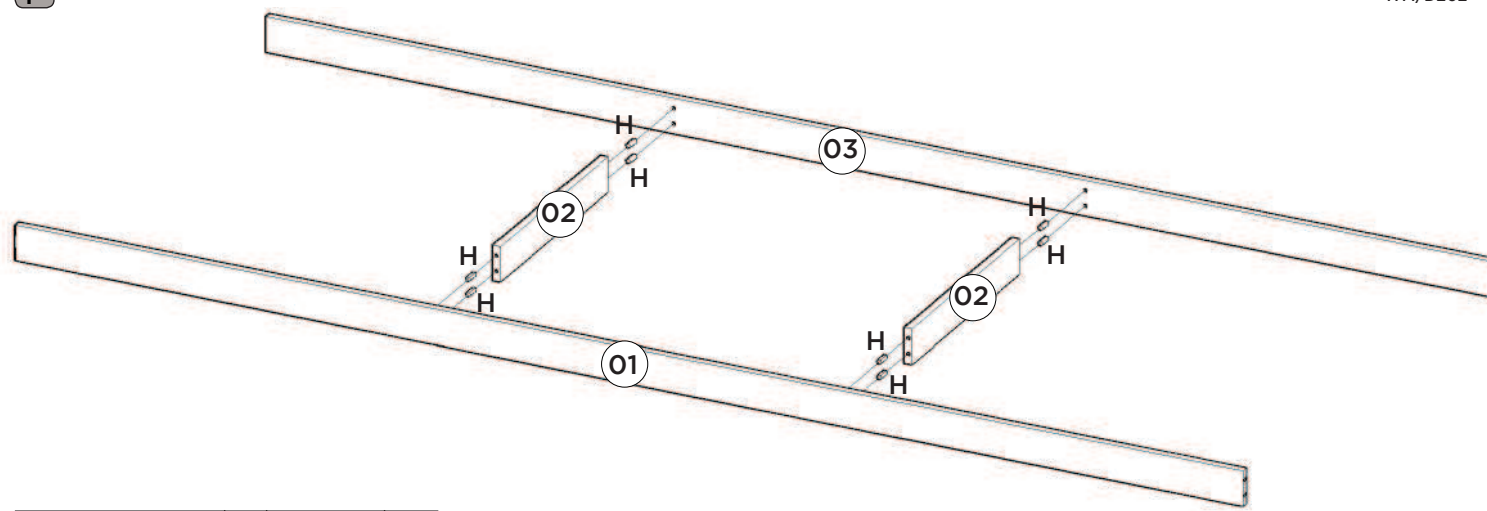

The products' assembly system works according to the increasing order of the indicated numbers. For example: 01, 02, 03, 04 ... to the end of the assembly.







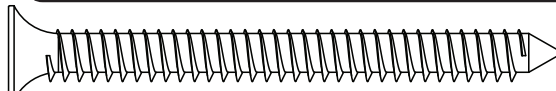
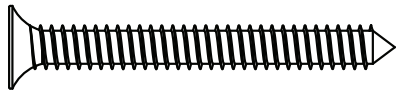
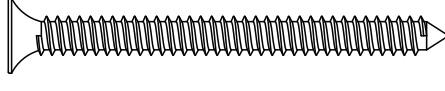
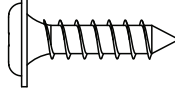
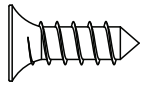
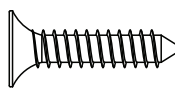
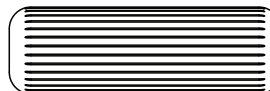

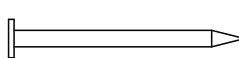



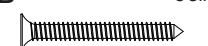

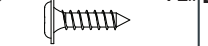



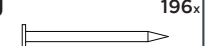
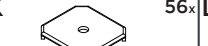

Utilizar componentes abaixo para que sejam conferidos (Escala 1:1)

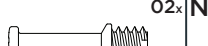
El uso de componentes a continuación con el fin de conceder (Escala 1:1)

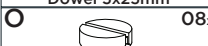
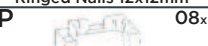
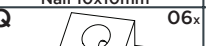
Use components below to be checked (Scale 1: 1)

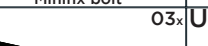
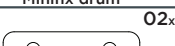
- A  Parafuso 4,5x50mm CHT.
- B  Parafuso 4,0x35mm CHT.
- C  Parafuso 3,5x40mm CHT.
- D  Parafuso 3,5x14mm FLA.
- E  Parafuso 3,5x12mm CHT.
- F  Parafuso 3,0x16mm CHT.
- G  Cavilha 8x25mm
- H  Cavilha 5x25mm
- I  Pregão 12x12 anelado
- J  Pregão 10x10

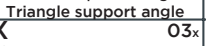
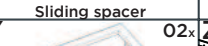
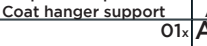
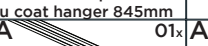
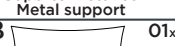
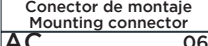
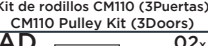
Ferragens | Herrajes | Hardware

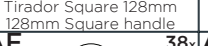
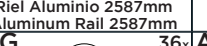
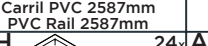
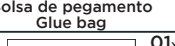
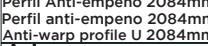
A  08x Parafuso 4,5x50mm CHT. Tornillo 4,5x50mm CHT. Screw 4,5x50mm CHT.	B  06x Parafuso 4,0x35mm CHT. Tornillo 4,0x35mm CHT. Screw 4,0x35mm CHT.	C  36x Parafuso 3,5x40mm CHT. Tornillo 3,5x40mm CHT. Screw 3,5x40mm CHT.	D  72x Parafuso 3,5x14mm FLA. Tornillo 3,5x14mm FLA. Screw 3,5x14mm FLA.	E  69x Parafuso 3,5x12mm CHT. Tornillo 3,5x12mm CHT. Screw 3,5x12mm CHT.	F  42x Parafuso 3,0x16mm FLA. Tornillo 3,0x16mm FLA. Screw 3,0x16mm FLA.	G  56x Cavilha 8x25mm Cinta 8x25mm Dowel 8x25mm
H  24x Cavilha 5x25mm Cinta 5x25mm Dowel 5x25mm	I  06x Pregão 12x12mm Anelado Clavo 12x12mm Anillado Ringed Nails 12x12mm	J  196x Pregão 10x10mm Clavo 10x10mm Nail 10x10mm	K  56x Fixador de fundos Fijador de fondos Bottom fixer	L  10x Cantoneira plástica Cantoneira plástica Plastic angle brackets	M  02x Parafuso minifix Tornillo minifix Minifix bolt	N  02x Tambor minifix Tambor minifix Minifix drum
O  08x Porca cilíndrica Tuerca cilíndrica Cylindrical nut	P  08x Pé "U" 50x40x100mm Pie "U" 50x40x100mm 50x40x100mm "U" feet	Q  06x Cantoneira suporte triangular Cantoneira soporte triangular Triangle support angle	R  06x Distanciador de corrediça Distanciador de deslizamiento Sliding spacer	S  06x Suporte cabideiro Soporte de percha Coat hanger support	T  03x Cabideiro Alum. 845mm Alu 845mm percha Alu coat hanger 845mm	U  02x Suporte metal Soporte metálico Metal support
V  13x Conector de montagem Conector de montaje Mounting connector	W  01x Kit Rodízio CM110 (3Portas) Kit de rodillos CM110 (3Puertas) CM110 Pulley Kit (3Doors)	X  03x Corrediça metal 350mm Corredora de metal 350mm Sliding metal 350mm	Y  02x Puxador Square 128mm Tirador Square 128mm 128mm Square handle	Z  01x Trilho Alumínio 2587mm Riel Aluminio 2587mm Aluminum Rail 2587mm	AA  01x Trilho PVC 2587mm Carril PVC 2587mm PVC Rail 2587mm	AB  01x Sachê de cola Bolsa de pegamento Glue bag
AC  06x Perfil Anti-empeno 2084mm Perfil anti-empeno 2084mm Anti-warp profile U 2084mm	AD  02x Giz de correção Tiza de corrección Chalk of correction	AE  02x Adesivo tapa parafuso 17mm Adhesivo tapón de tornillo 17mm Bolt cover adhesive 17mm	AF  38x Adesivo tapa parafuso 10mm Adhesivo tapón de tornillo 10mm Bolt cover adhesive 10mm	AG  36x Adesivo tapa parafuso 10mm Perfil Adhesivo tapón de tornillo 10mm Perfil Bolt cover adhesive 10mm Profile	AH  24x Batente PVC para Porta Parada de PVC para Puerta PVC Door Stop	AI  01x Etiqueta resinada Henn Etiqueta resinada Henn Henn resin label
AJ  03x Perfil "H" 1694mm Perfil "H" 1694mm Profile "H" 1694mm						

