

Mesa Apoio Vip

Mesa Apoio Vip / Vip End Table

Versão 1.0 / Versión 1.0 / Version 1.0



As ferramentas de montagem não são fornecidas.
www.artely.com.br

Conservação e Limpeza

Conservación y Limpieza
Conservation and Cleanness

Não expor o produto ao sol, altas temperaturas e umidade, não arrastar objetos sobre a superfície do móvel (ex.: TV, DVD, aparelho de som, objetos decorativos...) e mantendo-o em local seco e arejado. Para a limpeza, utilizar um pano seco e macio. Não é necessário o uso de materiais abrasivos ou álcool.

No exponga el producto a la luz solar, las altas temperaturas y la humedad, no arrastre los objetos a través de la superficie de la unidad (por ejemplo, TV, DVD, equipo de música, objetos de decoración ...) y mantenerlo en un lugar fresco y seco.

Para la limpieza, utilizar un paño seco y suave. El uso de materiales abrasivos o del alcohol no es necesario.



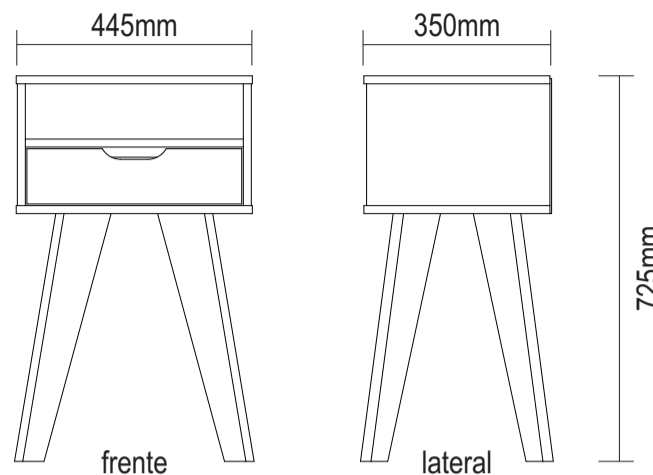





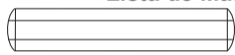
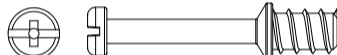

Do not expose the product to sunlight, high temperatures and humidity, do not drag objects across the surface of the unit (eg TV, DVD, stereo, decorative objects ...) and keeping it in a cool dry place. For cleaning, use a dry and soft cloth. Do not use abrasive materials or alcohol.

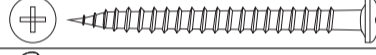

Assista ao vídeo com dicas de montagem em nosso site: www.artely.com.br

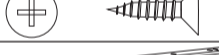
Lista de Materiais

Lista de Materiales/ Hardware List

Letra	Imagem	Descrição	Qtd
A		Cavilha	16
B		Minifix	08
C		Tambor	08
D		Tapa Furo Adesivo	08
E		Parafuso Ø3,5x40mm CP	04
F		Sapata Fixa Ø5x10mm	04
G		Parafuso Ø7x50mm CE	08
H		Chave Zeta	01
I		Parafuso Ø3,5x12mm CC	08
J		Corrediça 300mm	02
K		Corrediça 300mm	02
L		Cola	01
M		Prego 8x8	12

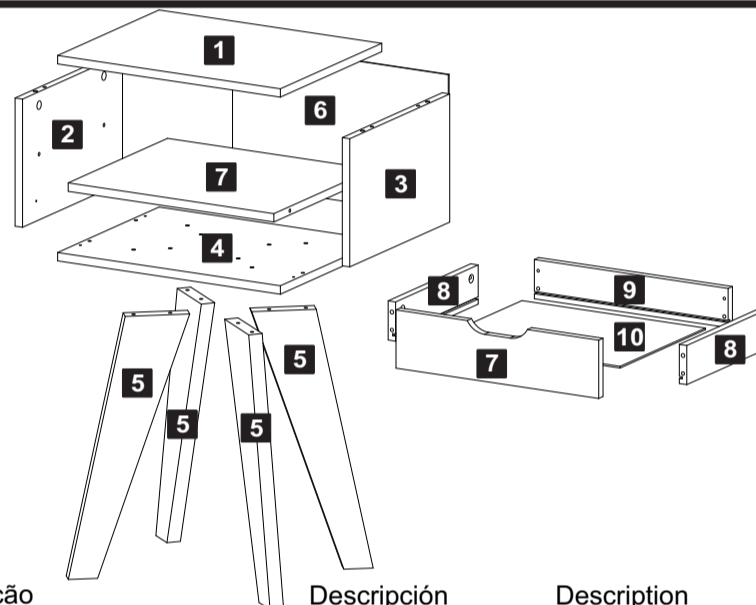

Descrição	Descripción	Description	Qtd
1-Tampo (444x350x15mm)	1-Tapa	1-Top	1
2-Lateral esq. (229x345x15mm)	2-Lateral izquierda	2-Left side	1
3-Lateral dir. (229x345x15mm)	3-Lateral derecha	3-Right side	1
4-Base (444x350x15mm)	4-Base	4-Base	1
5-Pé (500x110x25mm)	5-Pies	5-Feet	4
6-Traseira (430x254x3mm)	6-Trasera	6-Back	1
7-Prateleira (410x343x15mm)	7-Anaqueil	7-Shelf	1
8-Frente gaveta (404x104x15mm)	8-Frente cajón	8-Drawer front	1
9-Lateral gaveta (285x70x15mm)	9-Lateral cajón	9-Drawer side	2
10-Traseira gaveta (386x70x15mm)	10-Trasera cajón	10-Drawer back	1
11-Fundo gaveta (295x366x3mm)	11-Fondo cajón	11-Drawer bottom	1

1 Passo Paso Step

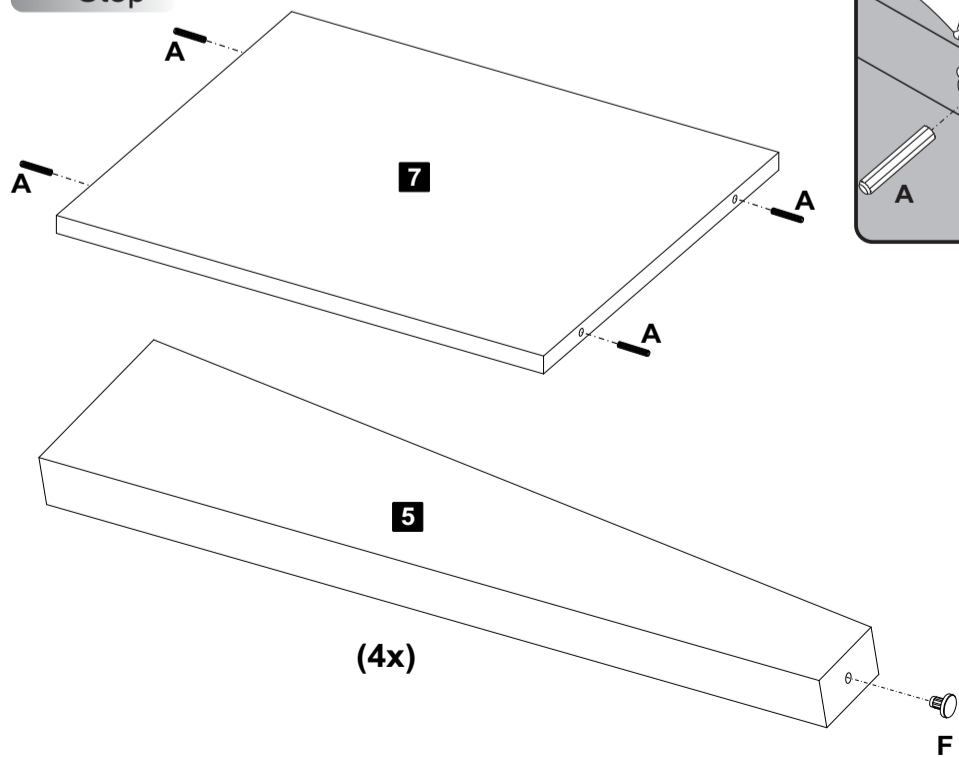

A Cavilha 04 F Sapata Fixa Ø5x10mm 04

2 Passo Paso Step

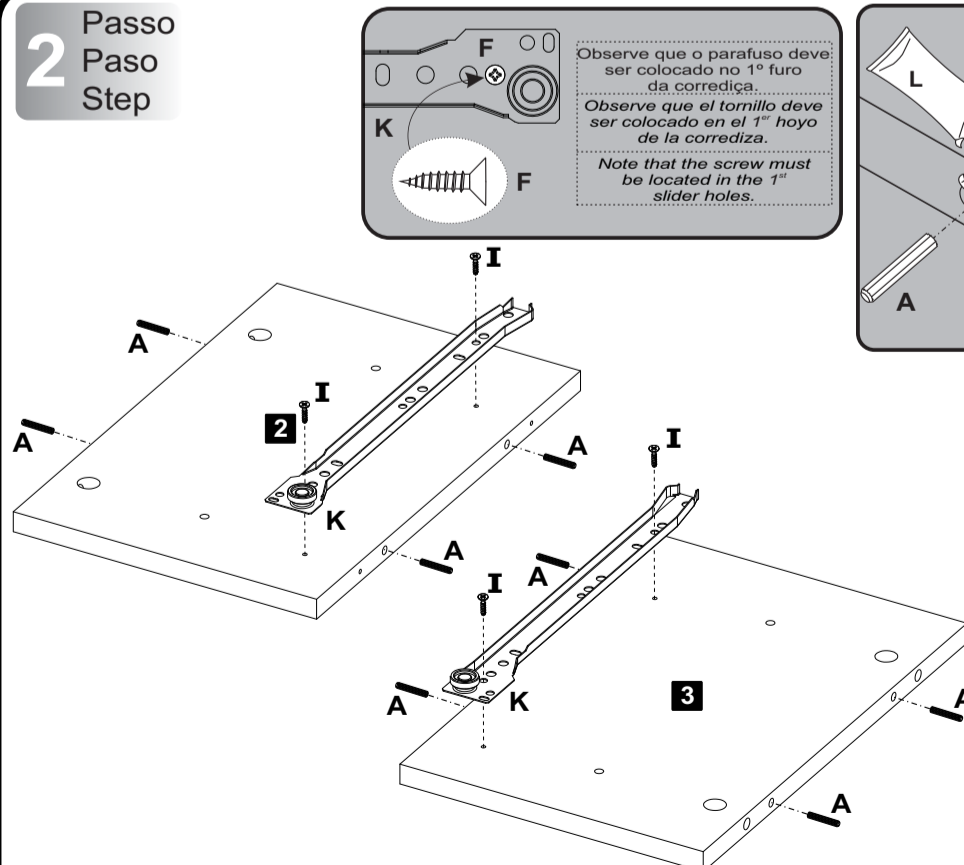

A Cavilha 08 I Parafuso Ø3,5x12mm CC 04 K Corrediça 300mm 02

3
Passo
Passo
Step

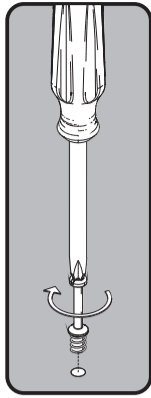
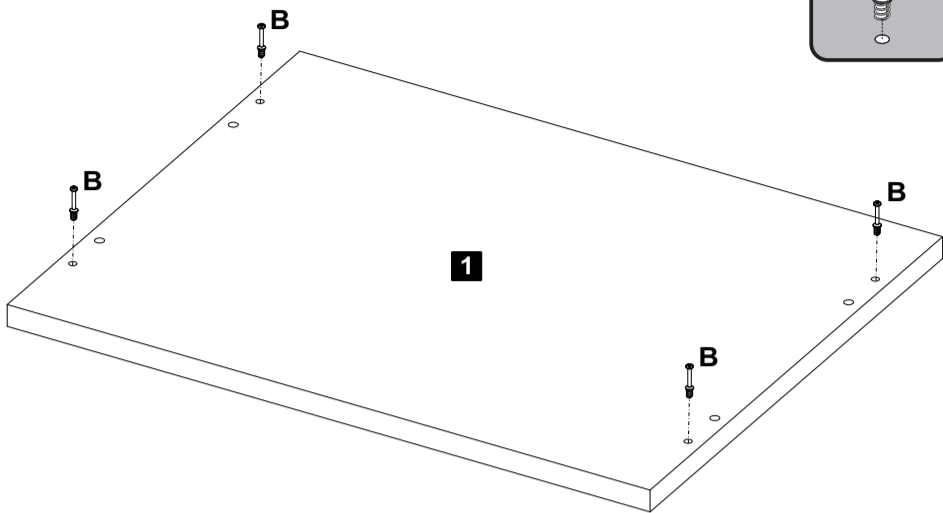

B  Mini fix
Ø7x30mm 04

4
Passo
Passo
Step

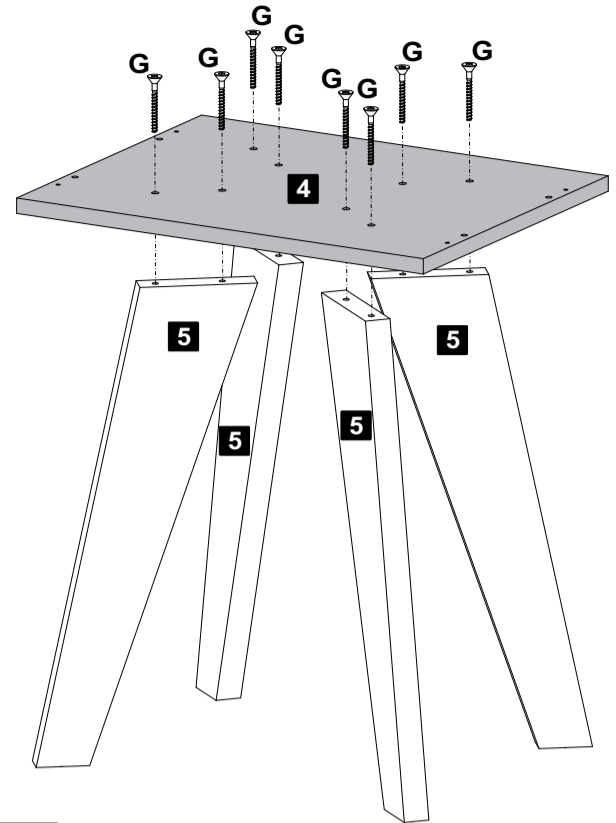

C  Parafuso
Ø7,0x50mm 08

5
Passo
Passo
Step

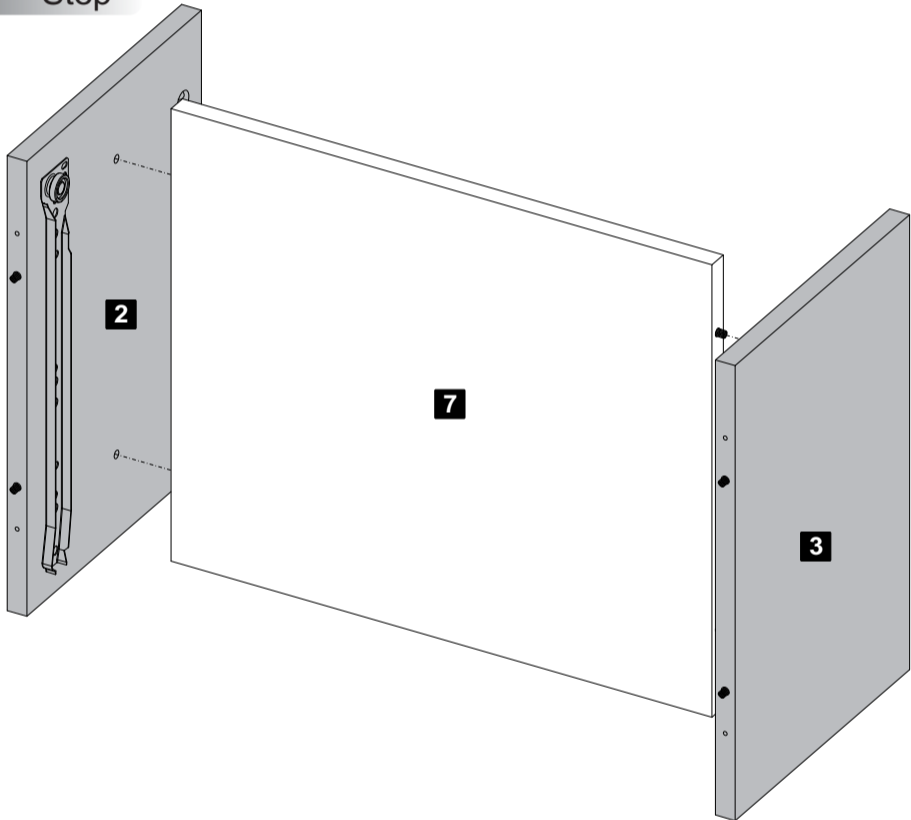

6
Passo
Passo
Step

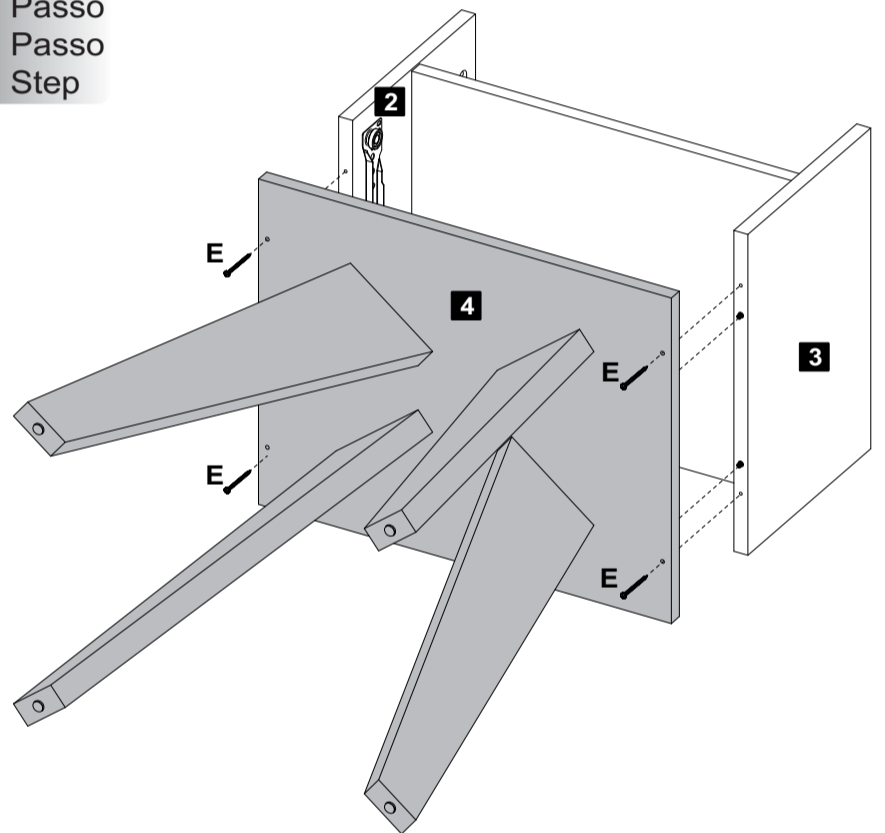

E  Parafuso
Ø3,5x40mm
CP 04

7
Passo
Passo
Step

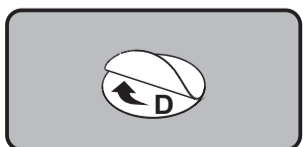
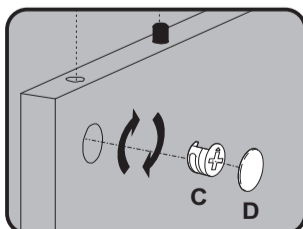
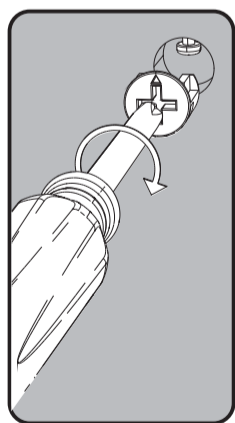
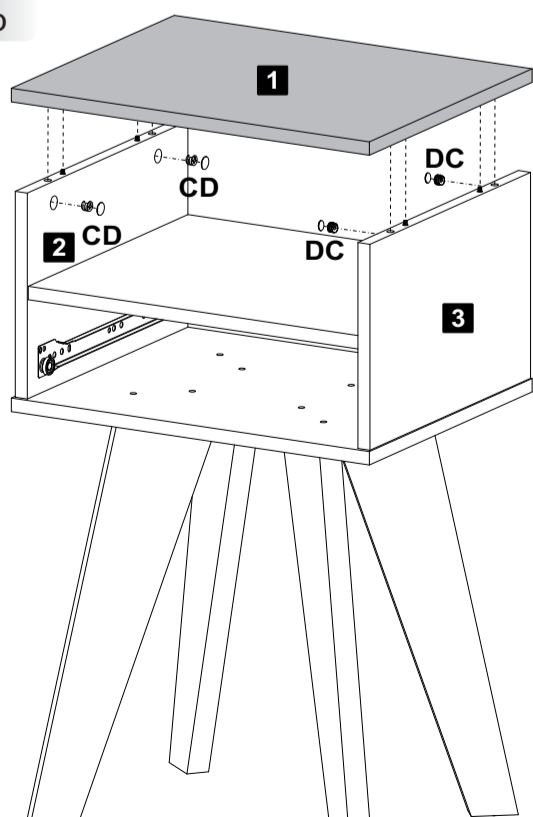

C  Tambor 04 D  Tapa
Furo Adesivo 04

8
Passo
Passo
Step

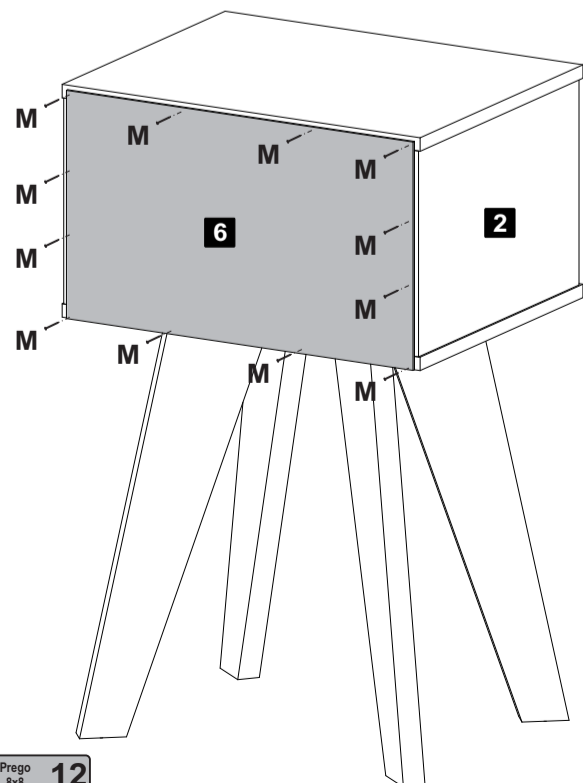

M  Prego
8x8 12

9
Passo
Passo
Step

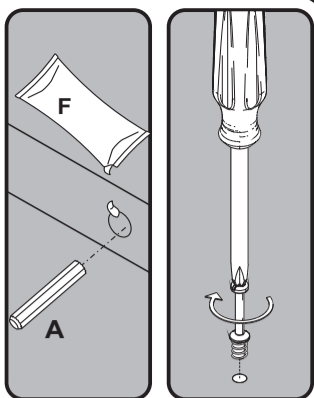
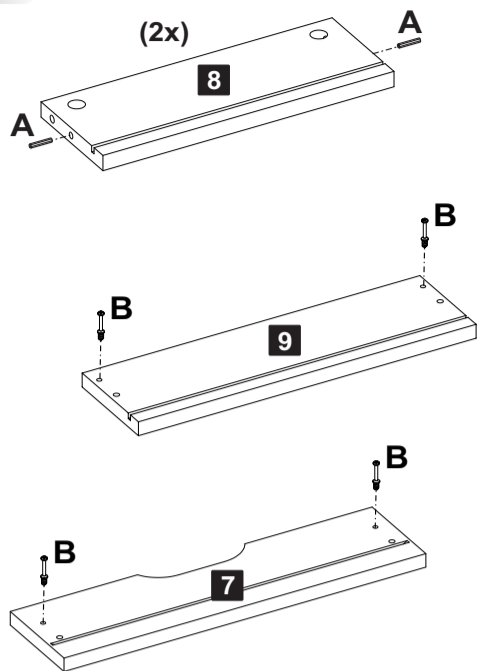

A Caviilha 04

B Minifix 07x30mm 04

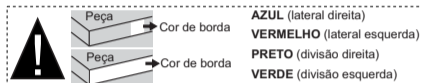

10
Passo
Passo
Step

1
Passo
Passo
Step

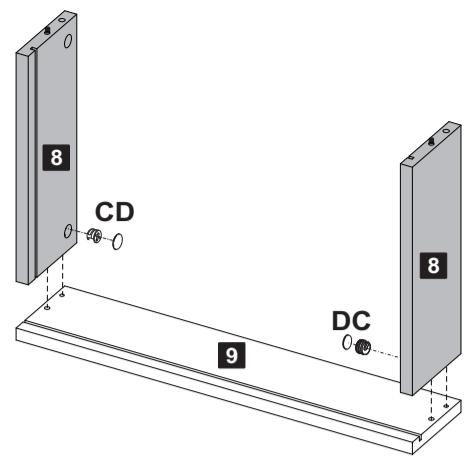

2
Passo
Passo
Step

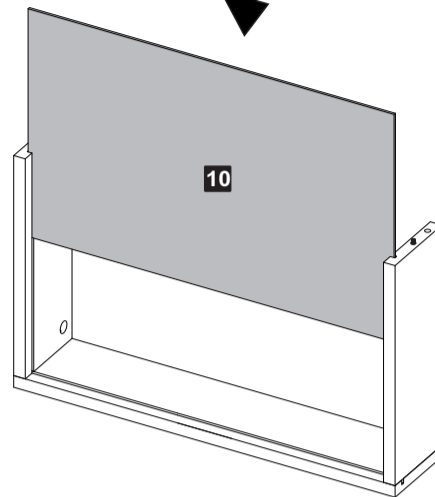

C Tambor 02

D Tapa Furo Adesivo 02

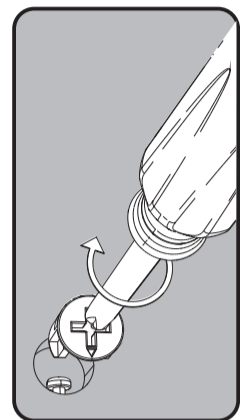
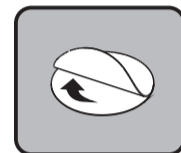

11
Passo
Passo
Step

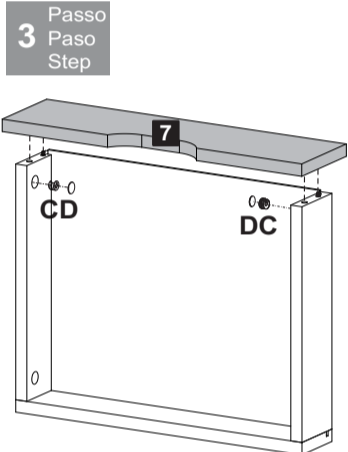

3
Passo
Passo
Step

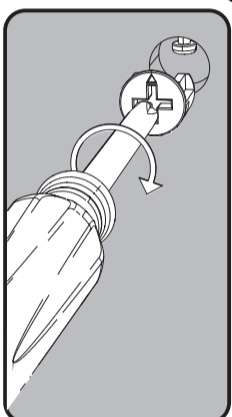
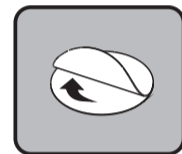

4
Passo
Passo
Step

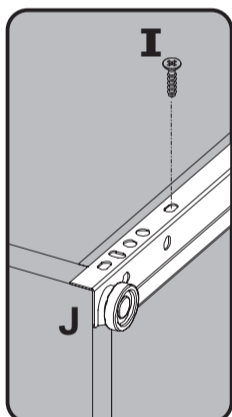
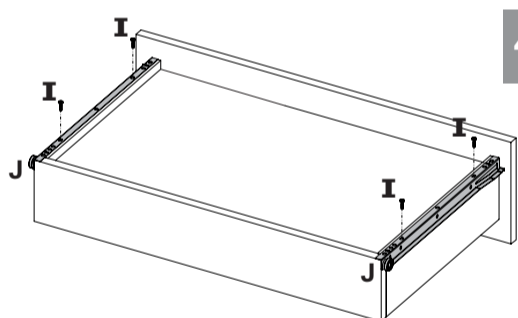

C Tambor 02

D Tapa Furo Adesivo 02

I Parafuso 03,5x12mm CC 04

J Corrediça 300mm 02

12
Passo
Passo
Step

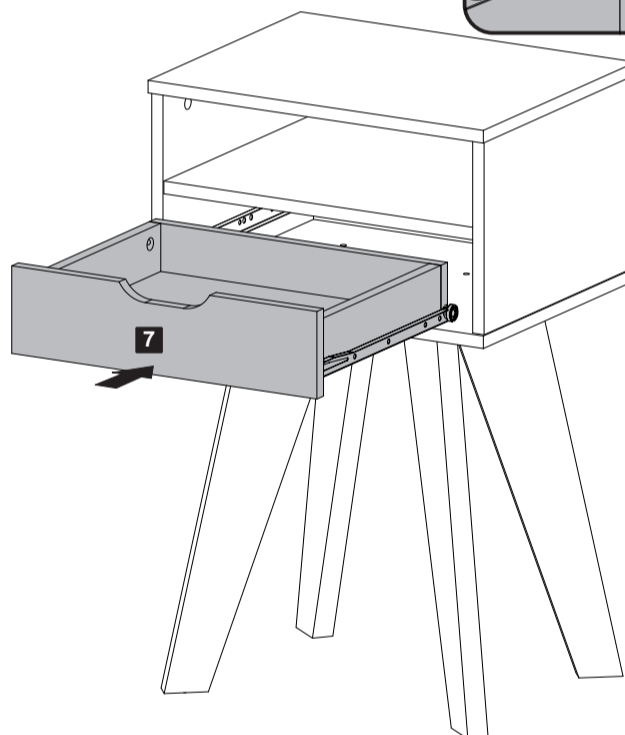
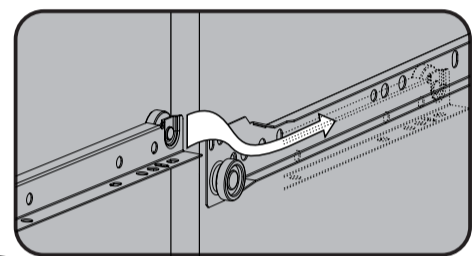

Garantia

Este certificado de Garantia é uma vantagem adicional oferecida ao consumidor, porém para que o mesmo tenha validade é imprescindível que seja apresentada a NOTA FISCAL de compra do produto.

Com este produto, a **Artely** tem como objetivo atender plenamente o proprietário-consumidor, proporcionando a garantia na forma aqui estabelecida, pelo período de três meses a partir da data da nota fiscal de compra. A **Artely** restringe a sua responsabilidade à substituição gratuita das peças defeituosas, em caso de defeitos ou avarias devidamente constatados como sendo de fabricação, durante a vigência desta garantia.

A **Artely** declara a garantia nula e sem efeito se o produto for alterado, adulterado, molhado ou consertado e ainda pela prática de montagem inadequada ou mau uso. Também será considerada nula em casos de força maior, como aqueles causados por agentes da Natureza (chuvas, incêndios, excesso de umidade...) e eventos externos como objetos arrastados sobre a superfície do móvel (ex.: TV, DVD, aparelho de som, objetos decorativos...).

Para exercer seus direitos de comprador é importante que antes de montar seu produto você leia com atenção as instruções de cada passo do manual de montagem que acompanha o móvel.

Caso o produto não esteja em conformidade, entre em contato com a loja onde efetuou a compra ou com o nosso Serviço de Atendimento ao Cliente através do e-mail assistencia@artely.com.br ou pelo fone 41 3381 5000 e faça sua reclamação, apontando os defeitos técnicos observados, que teremos o maior prazer em atendê-lo. Para agilizar o seu atendimento, tenha sempre em mãos o manual de montagem com os respectivos números das peças defeituosas, conforme descritas no manual.

ARTELY
Complementos para Sala

ARTELY MÓVEIS LTDA
ALAMEDA ARPO, 2333
CEP / ZIP CODE: 83010-290
SÃO JOSÉ DOS PINHAIS
CURITIBA - PR - BRASIL
Fone / Fax: 41 3381-5000
Phone Number: 55 41 3381-5000
e-mail: artely@artely.com.br
www.artely.com.br