

8465 GR TUCSON 06 PTS 09 GAV

8465 GR TUCSON 06 PTS 09 GAV

8465 GR TUCSON 06 PTS 09 GAV

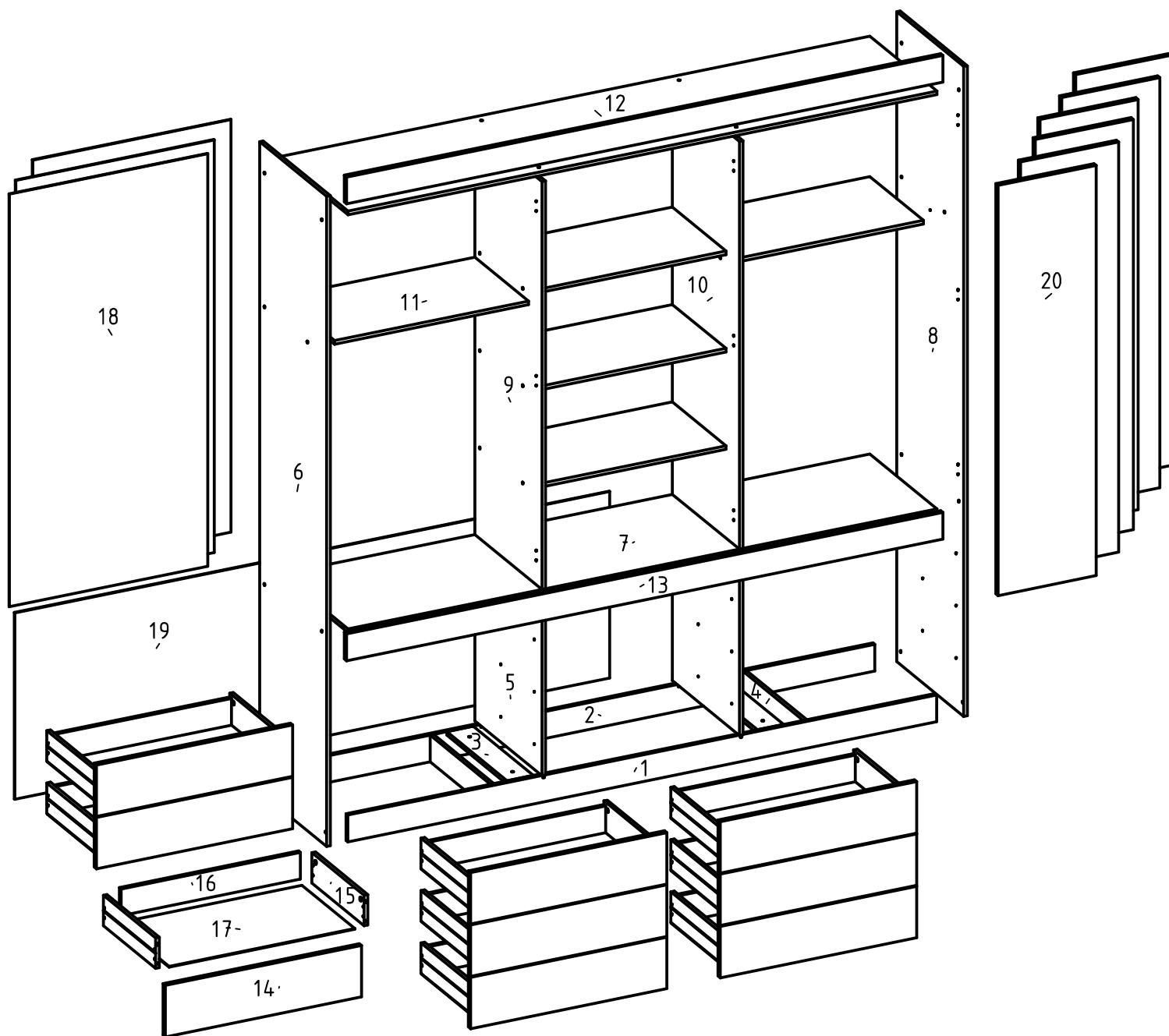

LISTA DE PEÇAS / Pieces List / Lista de Piezas

SEQ.	REF.	DESCRIÇÃO	DESCRIPTION	DESCRIPCIÓN	MAT.PRIMA	COMP.	LARG.	ESP.	QTD.
1	7788	RODAPE FRONTAL	FRONT FOOTING	ZOCALO FRONTAL	MDP	1974	88	12	1
2	7789	RODAPE TRASEIRO	BACK FOOTING	ZOCALO TRASEIRO	MDP	1974	88	12	1
3	7790	TRAVA DA DIVISORIA	CLOSURE OF THE DIVISION	TRAVA DE LA DIVISORIA	MDP	404	88	12	2
4	7791	TRAVA DO RODAPE	LOCKOUT	TRAVA RODAPE	MDP	404	88	12	2
5	7792	DIVISORIA INFERIOR	DIVISORIA INFERIOR	BOTTOM LIVING	MDP	600	450	12	2
6	7793	LATERAL ESQUERDA	LET SIDE	LATERAL IZQUIERDO	MDP	2136	450	12	1
7	7794	QUADRO INTERNO	BASE	BASE	MDP	1974	450	12	1
8	7795	LATERAL DIREITA	RIGHT SIDE	LATERAL DERECHO	MDP	2136	450	12	1
9	7796	DIVISORIA ESQUERDA	DIVISORIA ESQUERDA	LATERAL IZQUIERDO	MDP	1340	450	12	1
10	7797	DIVISORIA DIREITA	RIGHT DIVISION	DIVISORÍA DERECHA	MDP	1340	450	12	1
11	7798	PRATELEIRA	SHELF	PRATELERA	MDP	650	360	12	5
12	7799	CHAPEU	HAT	SOMBRERO	MDP	1974	450	12	1
13	7800	VISTA FRONTAL	FRONT VIEW	VISTA FRONTAL	MDP	1998	88	15	2
14	7801	FRENTE GAVETA	DRAWER FRONT	FRENTE DE GAVETA	MDP	658	169	15	9
15	7802	LATERAL GAVETA	DRAWER LATERAL	LATERAL GAVETA	MDP	350	100	12	18
16	7803	CONTRA FUNDO	AGAINDT FUND	CONTRA FONDO	MDP	601	88	12	9
17	7804	FUNDO DE GAVETA	DRAWER BACKGROUND	FONDO DE CAJÓN	HDF	623	355	3	9
18	7805	FUNDO SUPERIOR	BACKGROUND	FONDO	HDF	1356	665	3	3
19	7806	FUNDO INFERIOR	BACKGROUND	FONDO	HDF	1994	613	3	1
20	7807	PORTA	DOOR	PUERTA	MDP	1348	329	15	6

Data de lançamento: 25/09/2017

Versao:

Data de Atualização: 02/01/2018

Revisao: -

DETALHAMENTO
DETAL / DETALLES

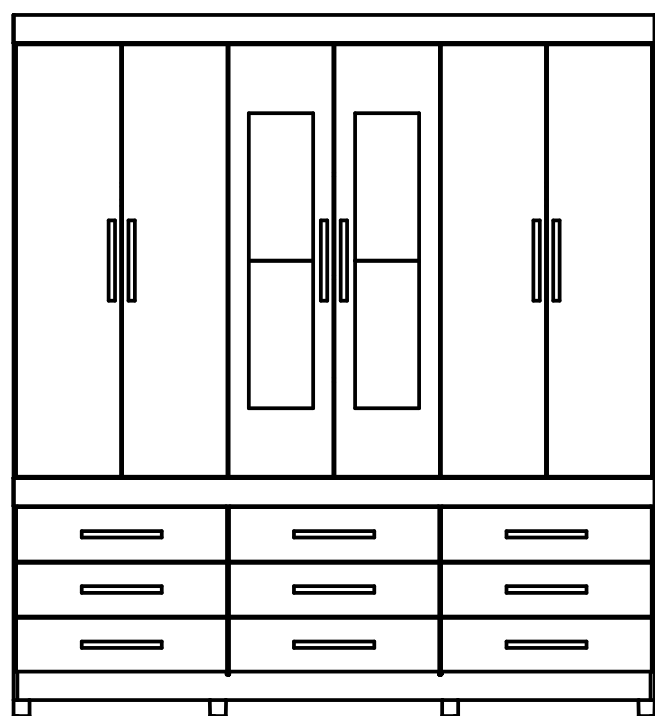

DETALHAMENTO
DETAL / DETALLES

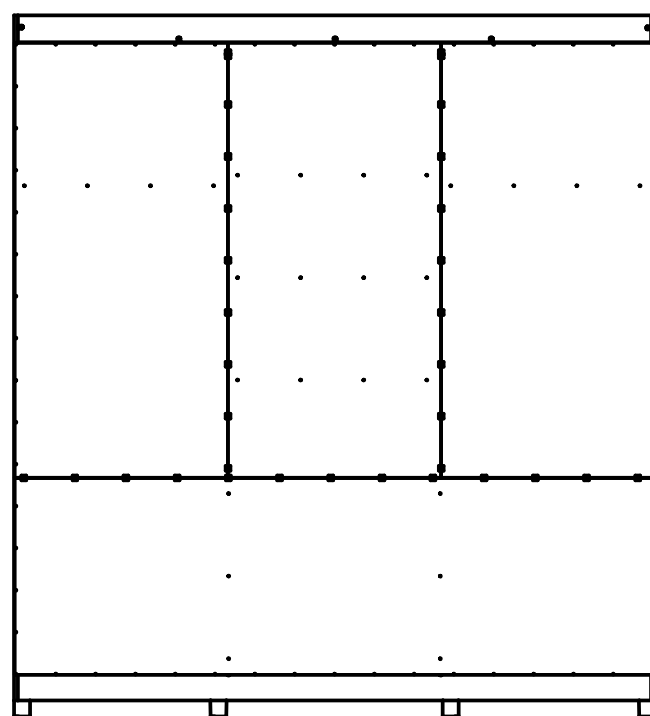

INSTRUÇÃO MONTAGEM PRODUTO

Intructions to Assembly / Instrucciones de montaje

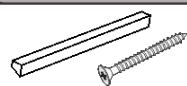

Separe as peças e acessórios de maneira organizada
Separate parts and accessories in way organized
Separe las piezas y accesorios de manera organizada

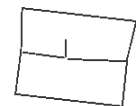

Forrar o chão com o papelão das embalagens.
Cover the floor with the cardboard
Cubra el suelo con la embalaje de cartón



É necessário 01 pessoa para montar o produto
It is necessary one person to assembly
Es necesario una persona para ensamblar

O produto deve ser a montado por um profissional qualificado
The product must be assembly by a professional
El producto debe ser ensamblado por un profesional calificado

Ferramentas necessárias
(não fornecidas)
Not include tools / No herramientas

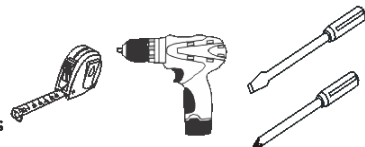

CUIDADO PARA CONSERVAÇÃO E LIMPEZA DO MÓVEL

Care to conservation and clean / Cuidados de limpieza



O peso máximo de carga informado refere-se a objetos distribuido de maneira uniforme sobre toda área de contato da peça
Set maximum weight load refers to objects distributed uniformly over the entire contact area of the workpiece.
Conjunto de carga máxima de peso se refiere a objetos distribuidos uniformemente sobre toda el área de contacto de la pieza de trabajo.



Não molhar o móvel e não expor em lugar úmido
Do not wet the mobile and do not expose in a wet place
No moje el producto y no exponer en un lugar húmedo



Não expor o móvel próximo de fontes de calor.
Do not expose the mobile near heat sources
no esponga cercano de fuentes de calor



Não usar produtos abrasivos.
Do not use abrasive products.
No utilice productos abrasivos.



Limpe com flanela limpa e seca.
Clean with dry cloth
Limpieza con un paño limpio y seco

LISTA DE ACESSÓRIOS E FERRAGEM / ACCESSORIES AND HARDWARE / ACCESORIOS Y EQUIPOS







	<p>A</p> <p>589 PARAFUSO 4.5 X 45 CHATA PHILIPS 48 UNID Screw 4.5 X 45 / Tornillo 4.5 X 45</p>	<p>B</p> <p>580 PARAFUSO 3.5 X 12 CHATA PHILIPS 120 UNID Screw 3.5 X 12 / Tornillo 3.5 X 12</p>	<p>C</p> <p>574 PARAFUSO MINIFIX ZAMAC 33 MM 18 UNID Minifix screw 33 mm / Tornillo minifix 33 mm</p>
<p>D</p> <p>755 CANTONEIRA GAVETA 16 UNID Corner drawer / Cantonera cajón</p>	<p>E</p> <p>582 PARAFUSO 3.5 X 25 CHATA PHILIPS 66 UNID Screw 3.5 X 25 / Tornillo 3.5 X 25</p>	<p>F</p> <p>579 PARAFUSO 3 X 12 CHATA PHILIPS 144 UNID Screw 3.0 X 12 / Tornillo 3.0 X 12</p>	<p>G</p> <p>7713 CORREDICA TELESC 300 MM 09 UNID Telescopic slide / Corredica Telescópica</p>
<p>H</p> <p>753 CAVILHA MADEIRA 6 X 30 MM 22 UNID Wood Bolts / Cuchillo de madera</p>	<p>I</p> <p>575 TAMBOR MINIFIX Ø12 X 11 MM 18 UNID Minifix Drum / Tambor Minifix</p>	<p>J</p> <p>602 DOBRADICA 26 MM RETA 18 UNID Hinge / dobladica</p>	<p>K</p> <p>PERFIL PUXADOR 250 MM15 UNID Profile Handle / Perfil Tirador</p>
<p>L</p> <p>576 PREGO 10X10 COM CABECA 220 UNID Nail/ Clavo</p>	<p>M</p> <p>757 FIXADOR DE FUNDO 33 UNID Background Fixer / Fijador de fondos</p>	<p>N</p> <p>822 SUPORTE METALICO OBLONGO 04 UNID Oblong metal bracket / Soporte metálico oblongo</p>	<p>O</p> <p>TAPA FURO GIROFIX 36 UNID Girofix Hole Cover / Tapa Furo Girofix</p>
<p>P</p> <p>5563 TUBO ALUMINIO 640 MM 02 UNID Aluminum Tube / Tubo Aluminio</p>	<p>Q</p> <p>PES DE ROUPEIRO 50 X 50 X 100 MM 08 UNID Wardrobe Weights / Pesado de Roperio</p>	<p>-</p>	<p>-</p>

Data de lançamento: 25/09/2017

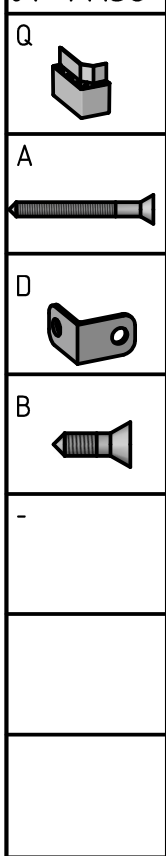
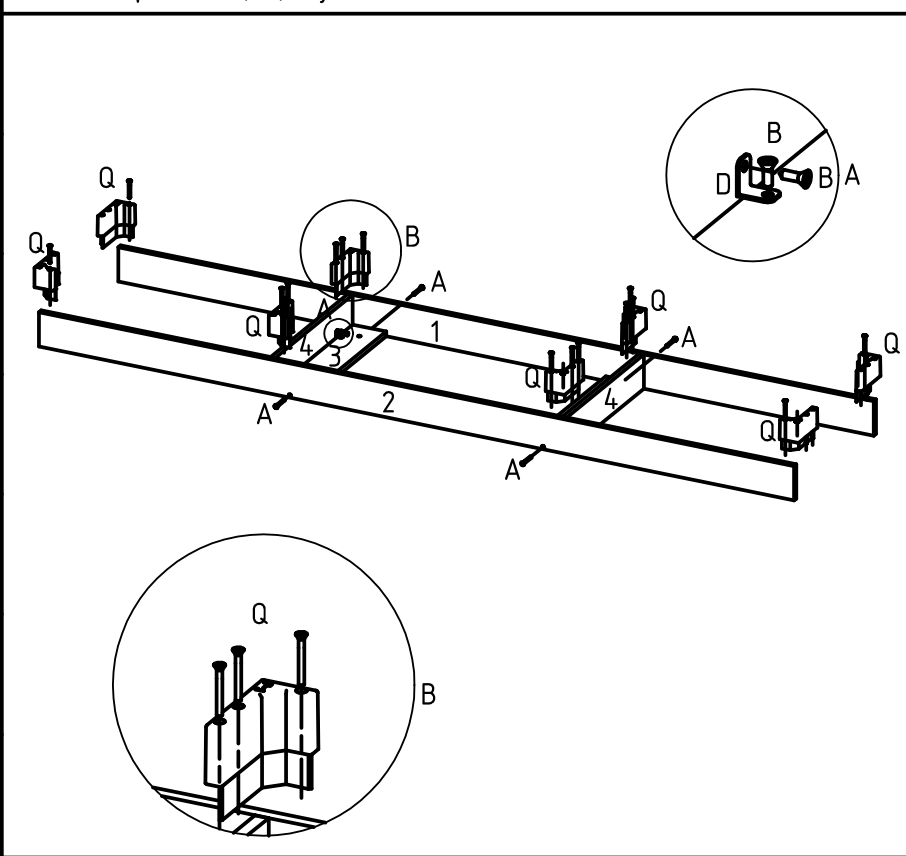
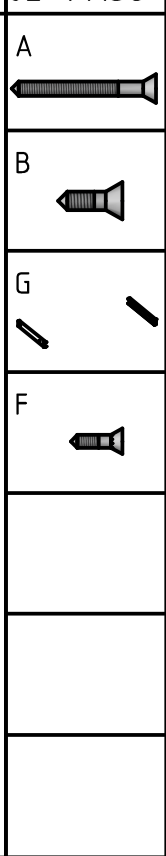
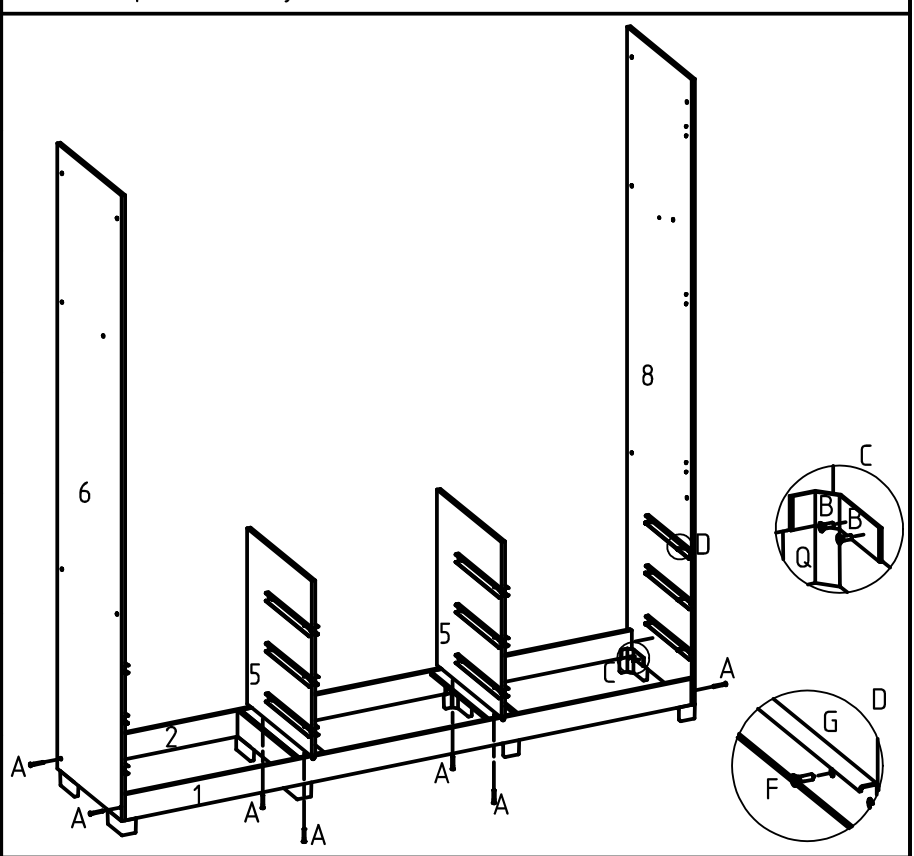
Versao:

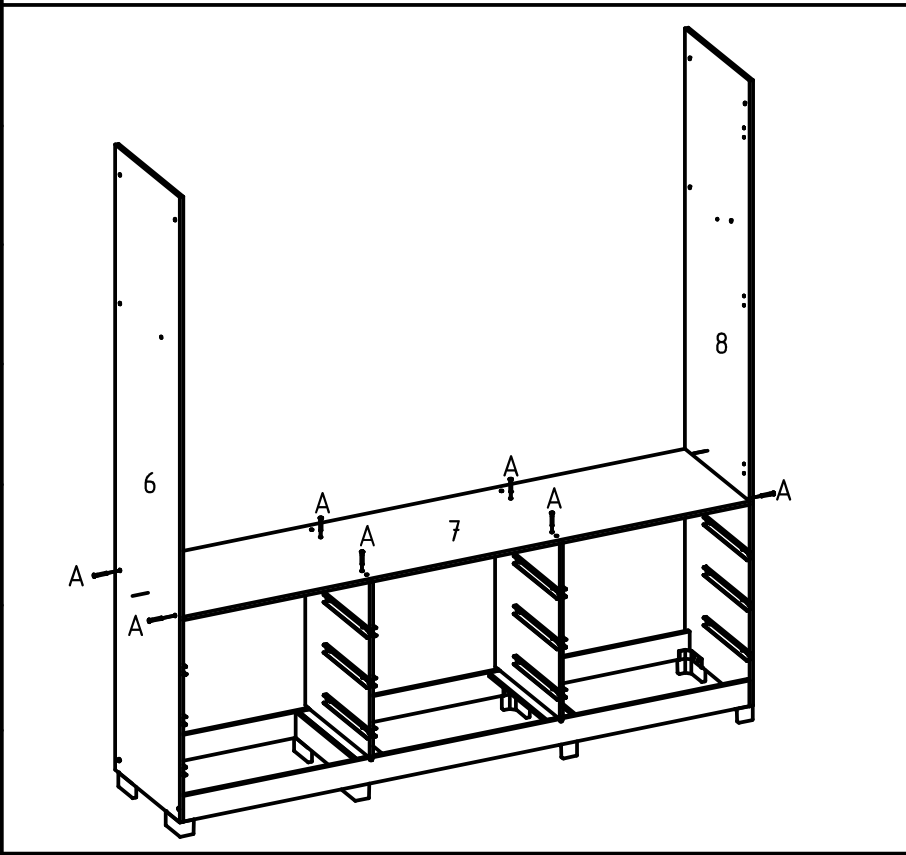
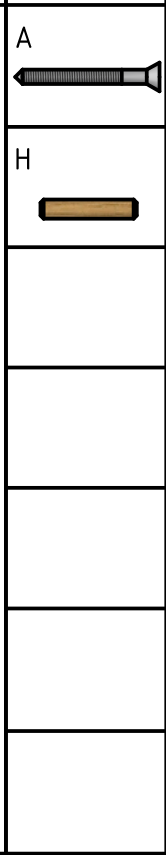
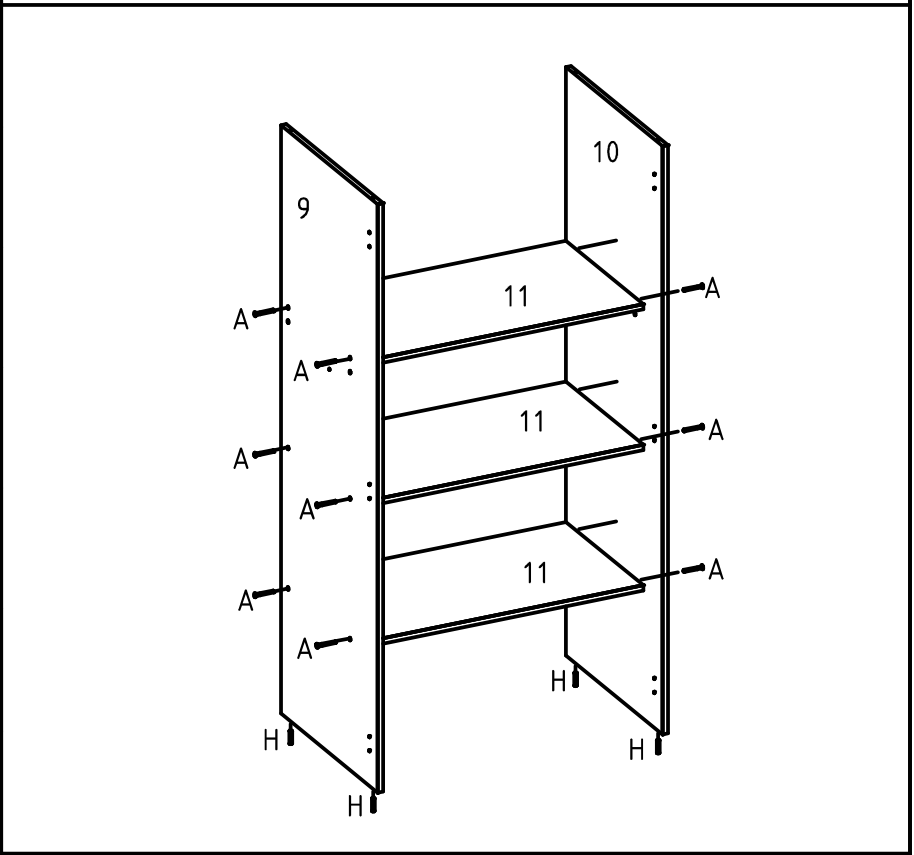
Data de Atualização: 02/01/2018

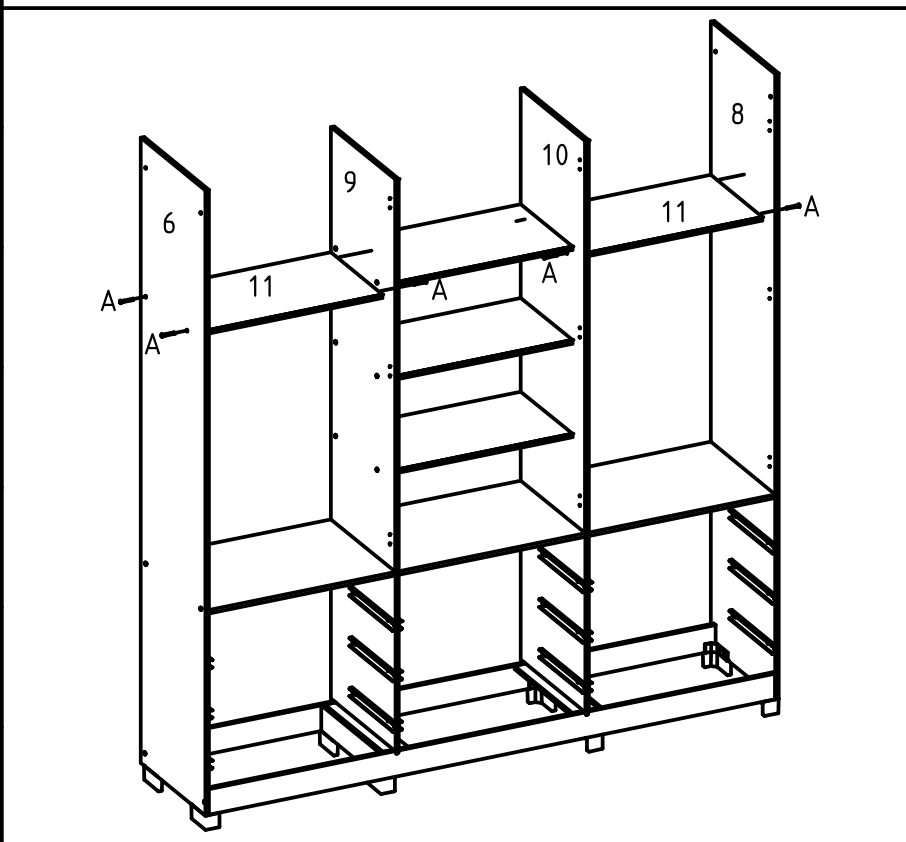
Revisao: -

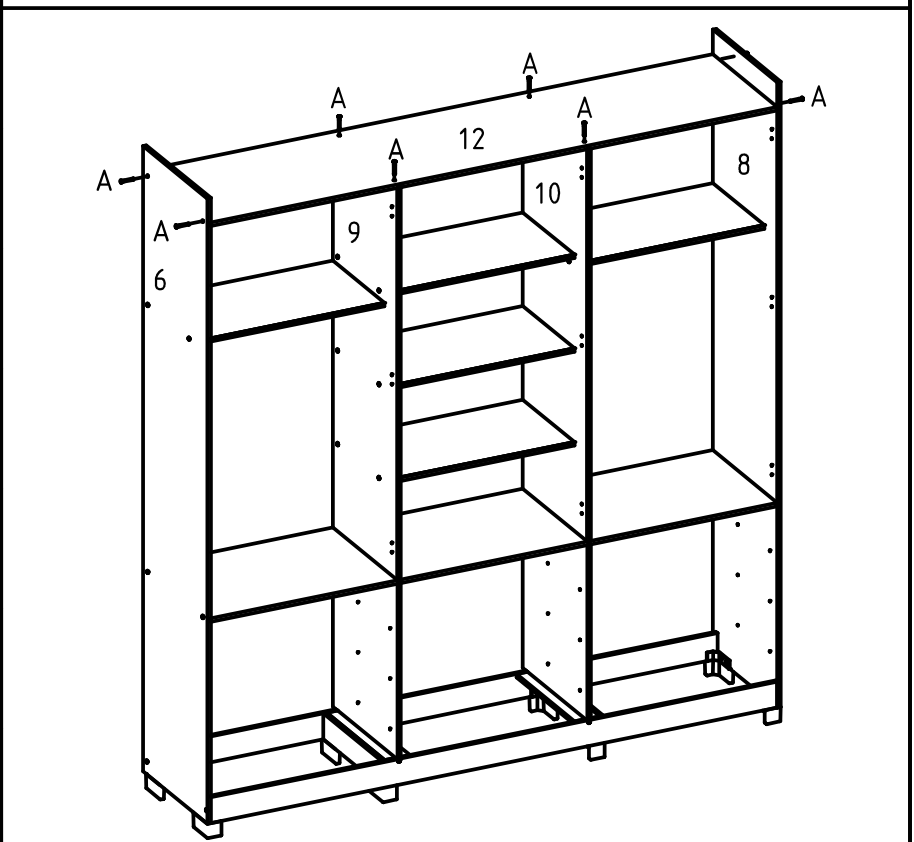
01° PASSO	Montar as peças 01,02,03 e 04.	02° PASSO	Montar as peças 05,06 e 08.
01° STEP	Assemble the parts 01,02,03 and 04.	02° STEP	Assemble parts 05,06 and 08.
01° PASO	Montar las piezas 01,02,03 y 04.	02° PASO	Montar las piezas 05,06 y 08.
			
03° PASSO	Fixar a peça 07 nas peças 06 e 08.	04° PASSO	Fixar as peças 11 nas peças 09 e 10.
03° STEP	Secure part 07 in parts 06 and 08.	04° STEP	Fasten parts 11 to parts 09 and 10.
03° PASO	Fijar la pieza 07 en las piezas 06 y 08.	04° PASO	Fijar las piezas 11 en las piezas 09 y 10.
			
05° PASSO	Fixar as peças 11 nas peças 06,09,10 e 08	06° PASSO	Fixar a peça 12 nas peças 06,09,10 e 08.
05° STEP	Fasten parts 11 to parts 06,09,10 and 08	06° STEP	Secure the part 12 in parts 06,09,10 and 08.
05° PASO	Fijar las piezas 11 en las piezas 06,09,10 y 08	06° PASO	Fijar la peça 12 en las piezas 06,09,10 y 08.
			

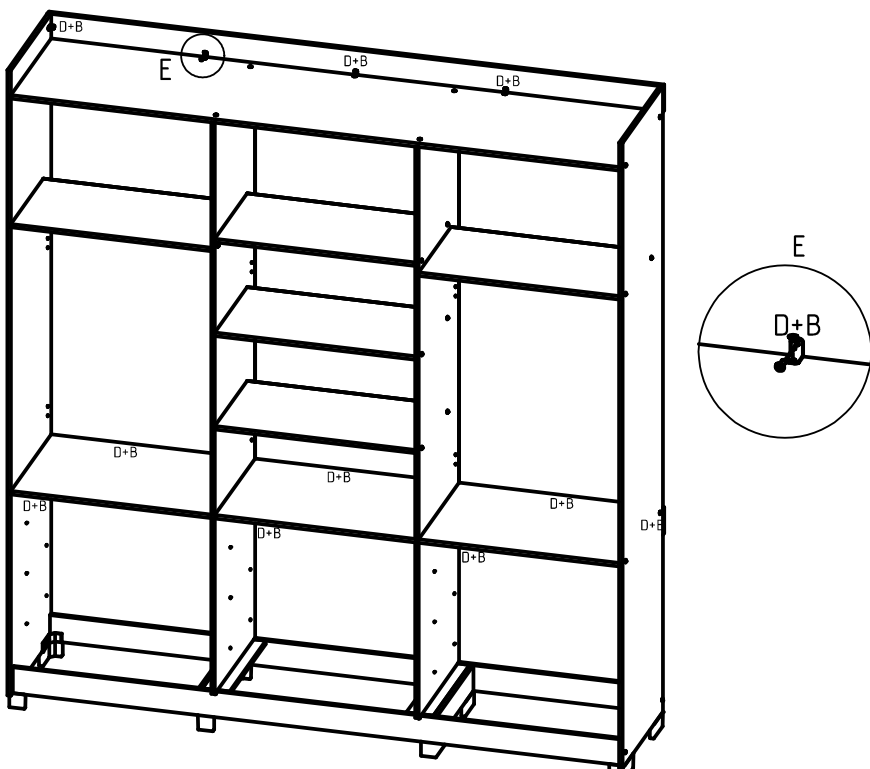
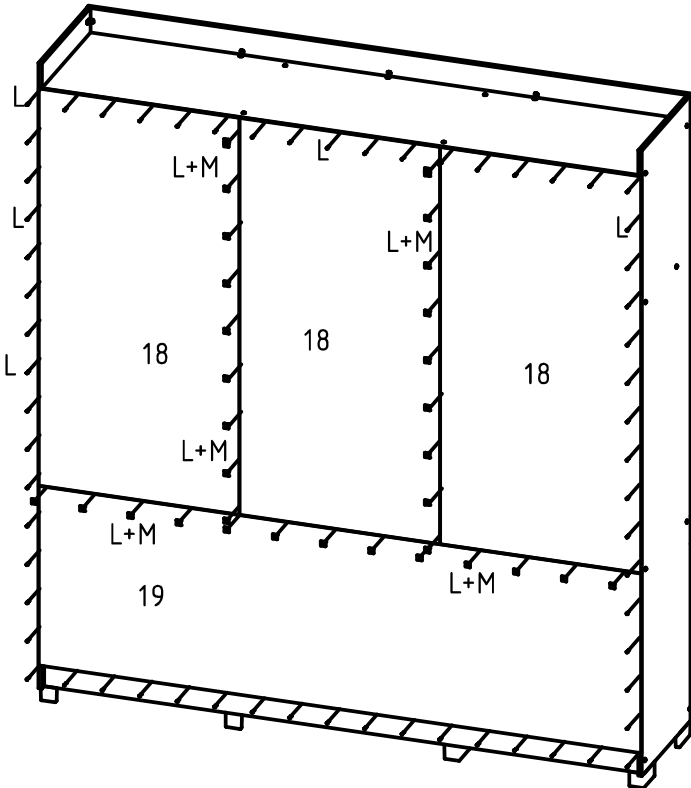
07° PASSO	Fixar as peças 13.	08° PASSO	Pregar os fundo.
07° STEP	Secure the parts 13.	08° STEP	Preach the background.
07° PASO	Fijar las piezas 13.	08° PASO	Predicción del fondo.
D B - - - -		M L - - - -	

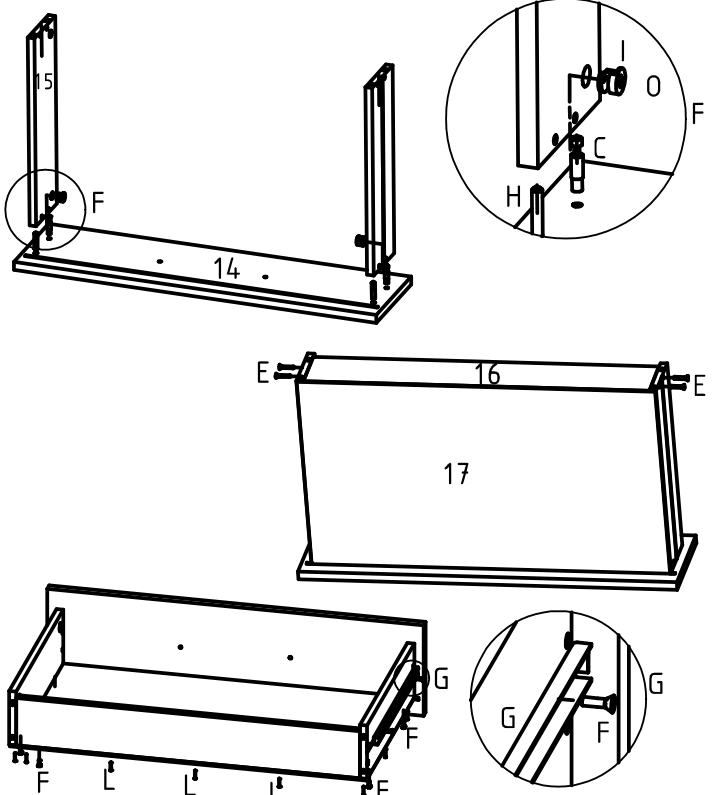
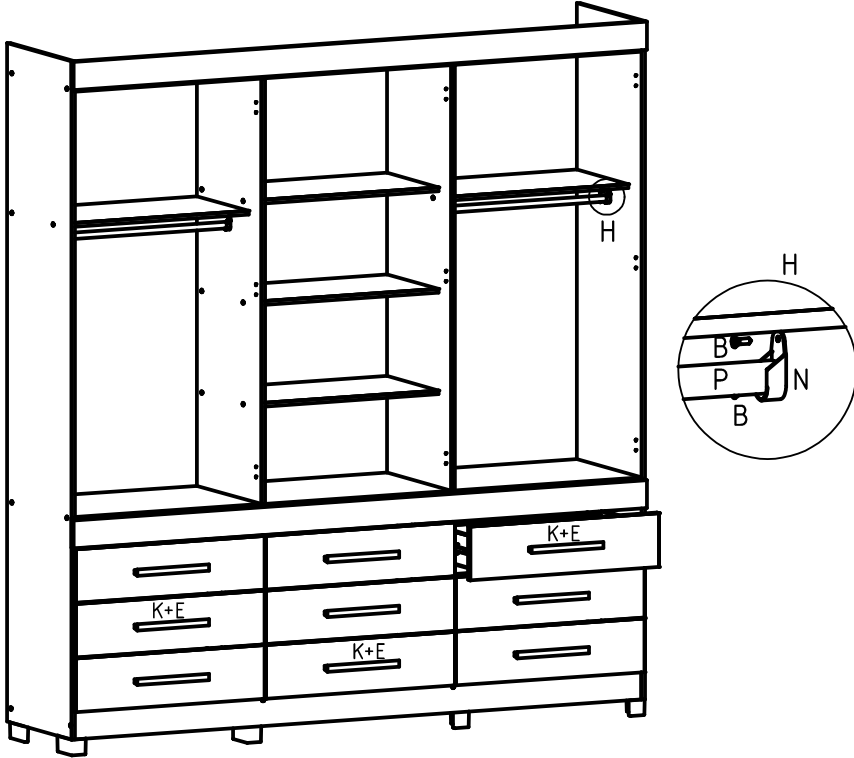
09° PASSO	Montar as Gavetas.	10° PASSO	Montar os cabideiros e encaixar as gavetas.
09° STEP	Assemble the Drawers.	10° STEP	Fit the racks and fit the drawers.
09° PASO	Montar los cajones.	10° PASO	Montar los caballetes y encajar los cajones.
H C I O E F G L		P N B K E	

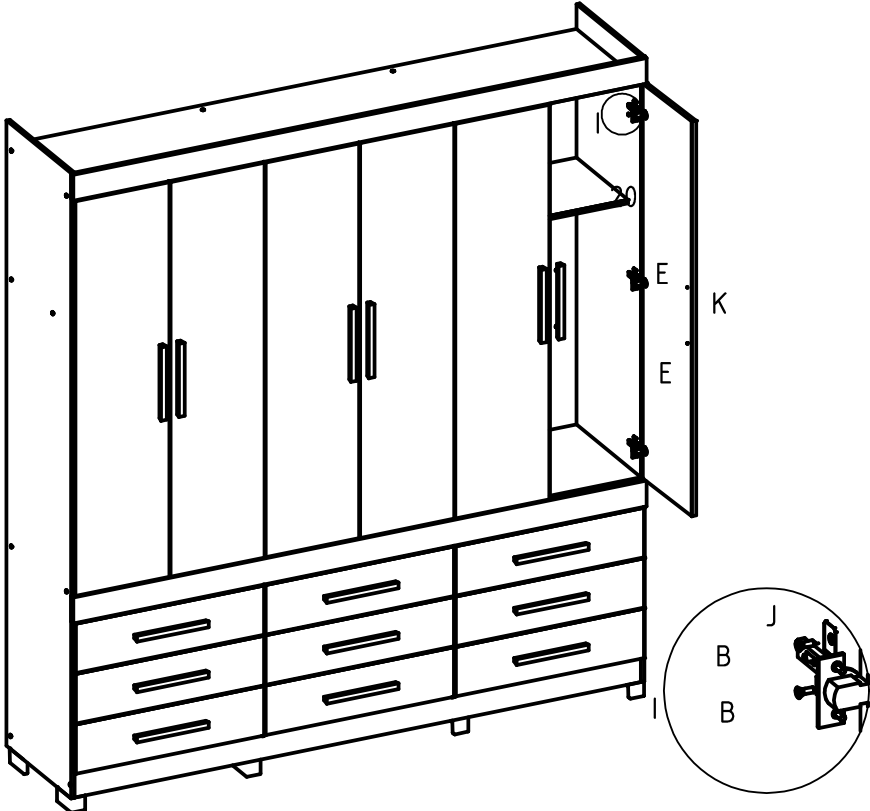
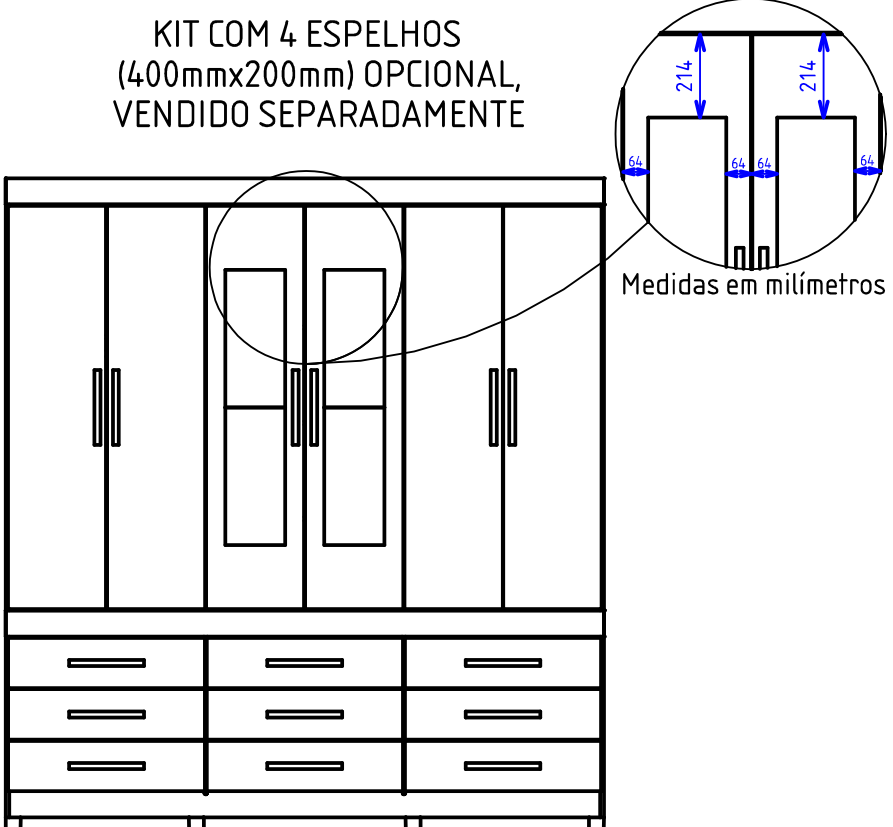
11° PASSO	Montar as portas no Móvel.	12° PASSO	Aspecto final do Produto.
11° STEP	Mount the doors on the Mobile.	12° STEP	Aspect of the Product.
11° PASO	Montar las puertas en el móvil.	12° PASO	Aspecto final del producto.
J E K B			<p>KIT COM 4 ESPELHOS (400mmx200mm) OPCIONAL, VENDIDO SEPARADAMENTE</p>  <p>Medidas em milímetros</p>