

REF.: 5714 / 5715

INSTRUÇÕES DE MONTAGEM
INSTRUCCIONES DE ARMADO
ASSEMBLY INSTRUCTIONS



REF. 5025



REF. 5028



REF. 5021



REF. 5029



REF. 5026/5032



REF. 5030



REF. 5122



REF. 5024



INSTRUÇÕES DE MONTAGEM INSTRUCCIONES DE ARMADO ASSEMBLY INSTRUCTIONS

REF.: 5021/5042/5043/
5047/5048/5049/
5055/5056/5059/5060

Fixação na Parede Montaje en la Pared Wall Assembly

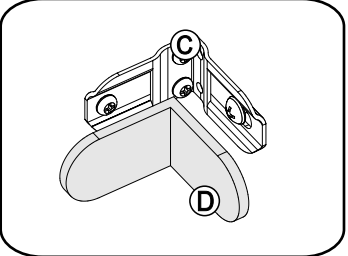
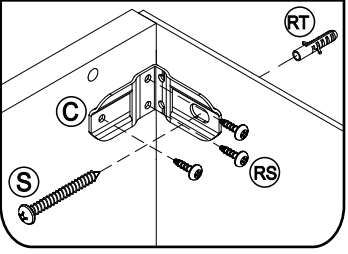

União dos Módulos Unión de los módulos Pieces Junction

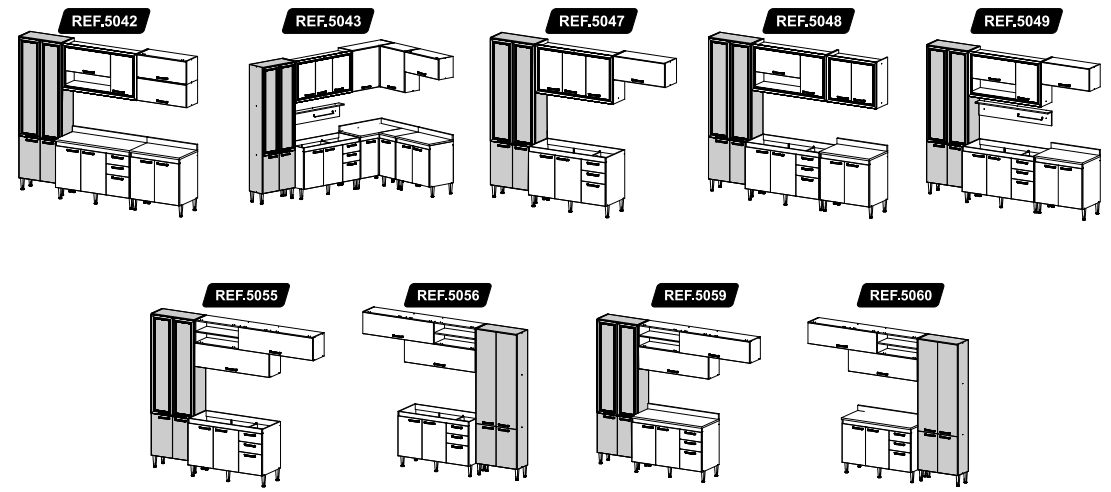
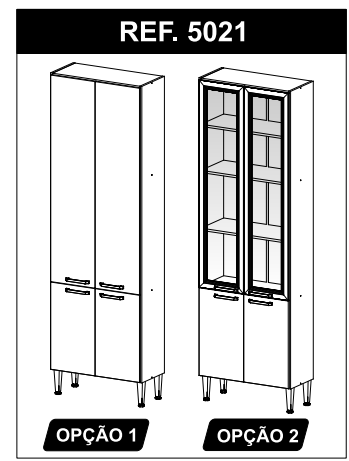
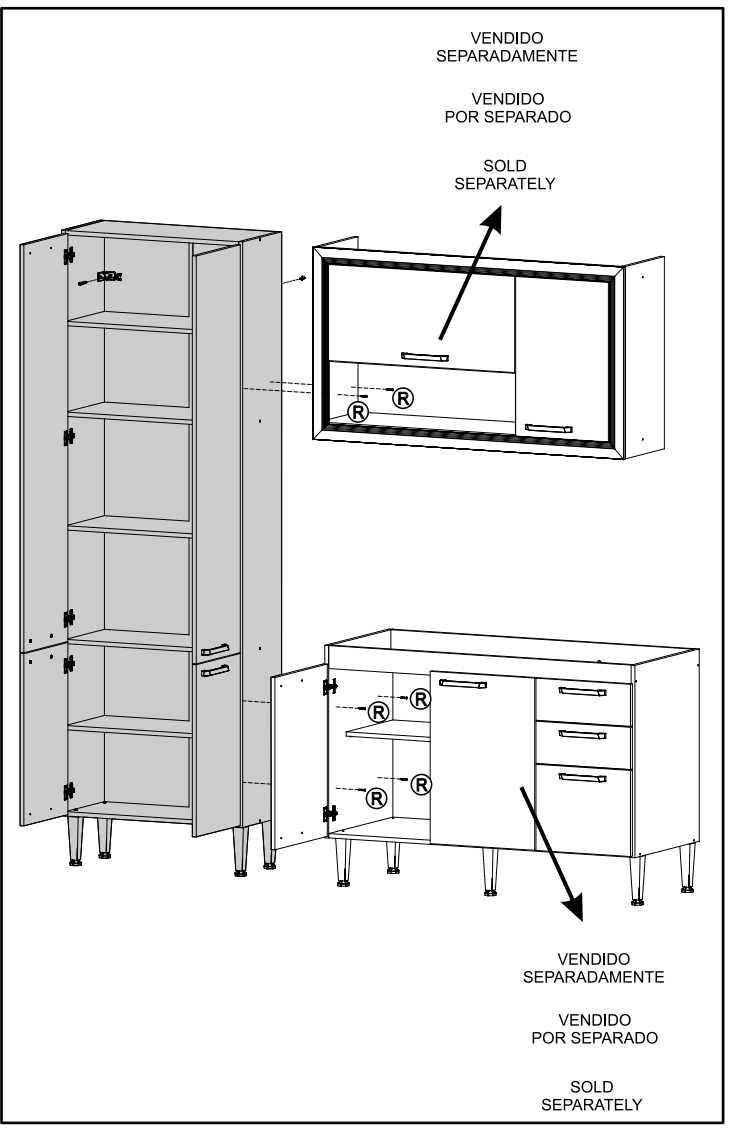
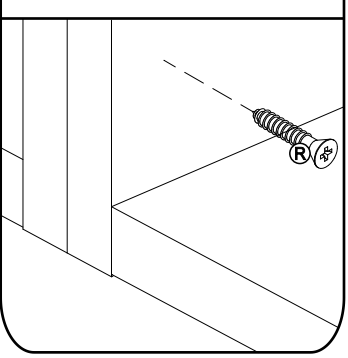





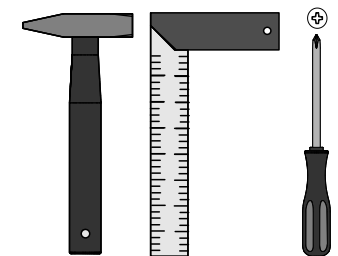
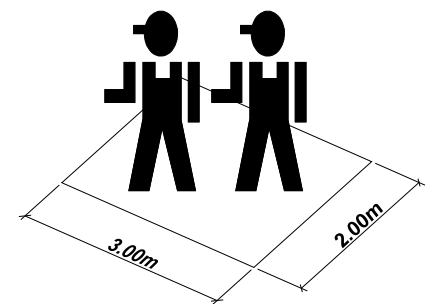







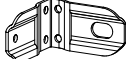
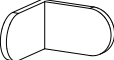

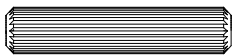
MULTIMÓVEIS
decor

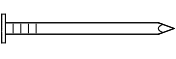
Rua Carlos Dreher Neto, 1918, Fone: (54) 2102 4000, FAX: (54) 2102 4050
CEP 95700-000 - BENTO GONÇALVES - RS - BRASIL
CNPJ: 00.349.443/0001-92
e-mail: multimoveis@multimoveis.com / site: www.multimoveis.com



LISTA DE FERRAGENS / LISTA DE MATERIALES / HARDWARE LIST

Passo
Paso
Step **04**

A		Tampa Adesiva	12
B		Parafuso 4,5 x 50	08
C		Suporte Aéreo	02
D		Capa p/ Suporte Aéreo	02
E		Parafuso 3,5 x 14	40
H		Cavilha 6,0 x 30	28
R		Parafuso 4,0 x 25	04
X		Pé com Regulagem	04
Y		Prego 10 x 10	60
AA		Dobradiça	10
BW		Parafuso 3,5 x 25	08
BX		Bisnaga de Cola 5g	01
XX		Puxador 160mm	04
S		5,0 x 45	06
RS		3,5 x 14	06
RT		Bucha Ø8mm	02

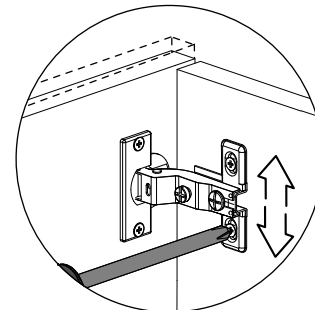
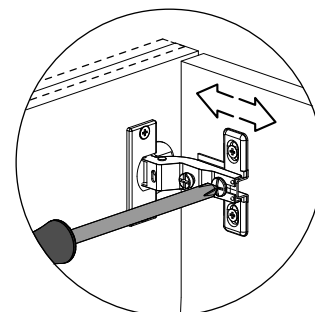
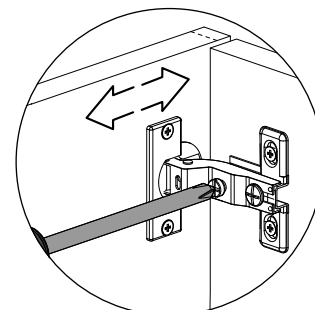
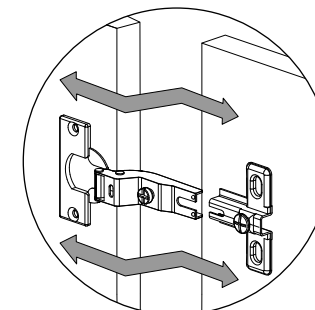
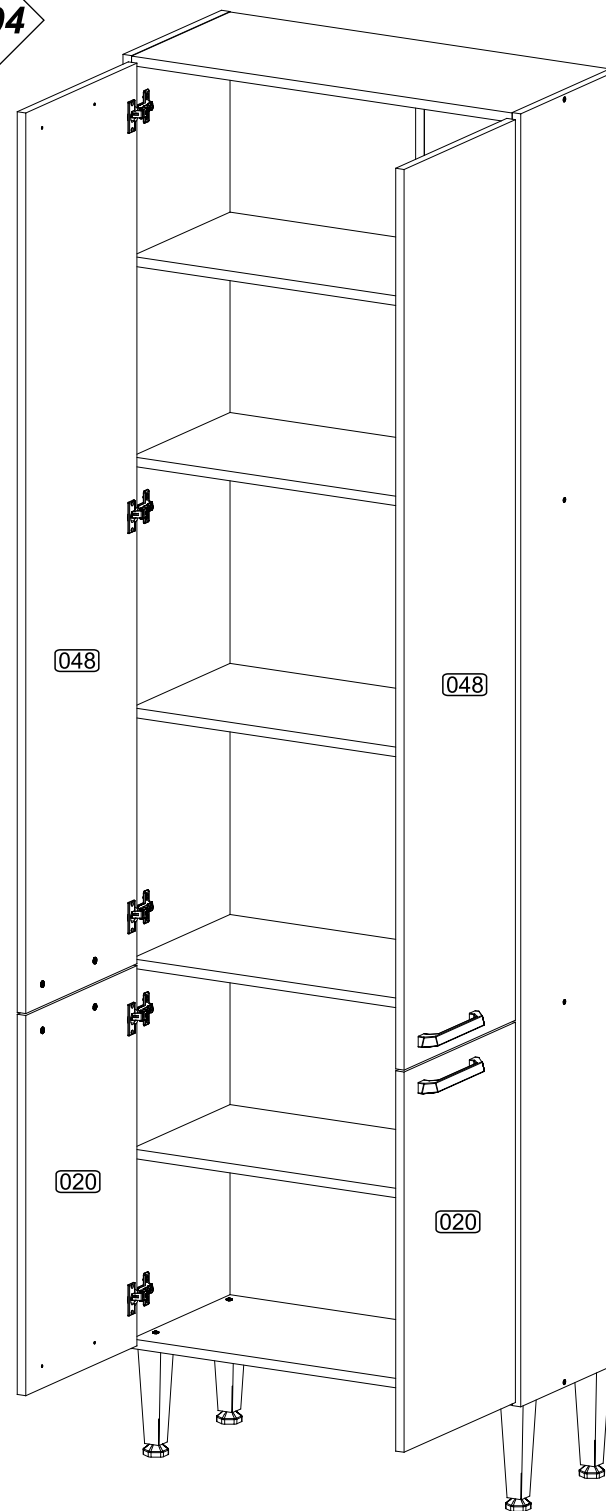

Ref.:5021 - 27/Junho/2016 - Rev. 07

Utilizar a régua abaixo para medir as ferragens:



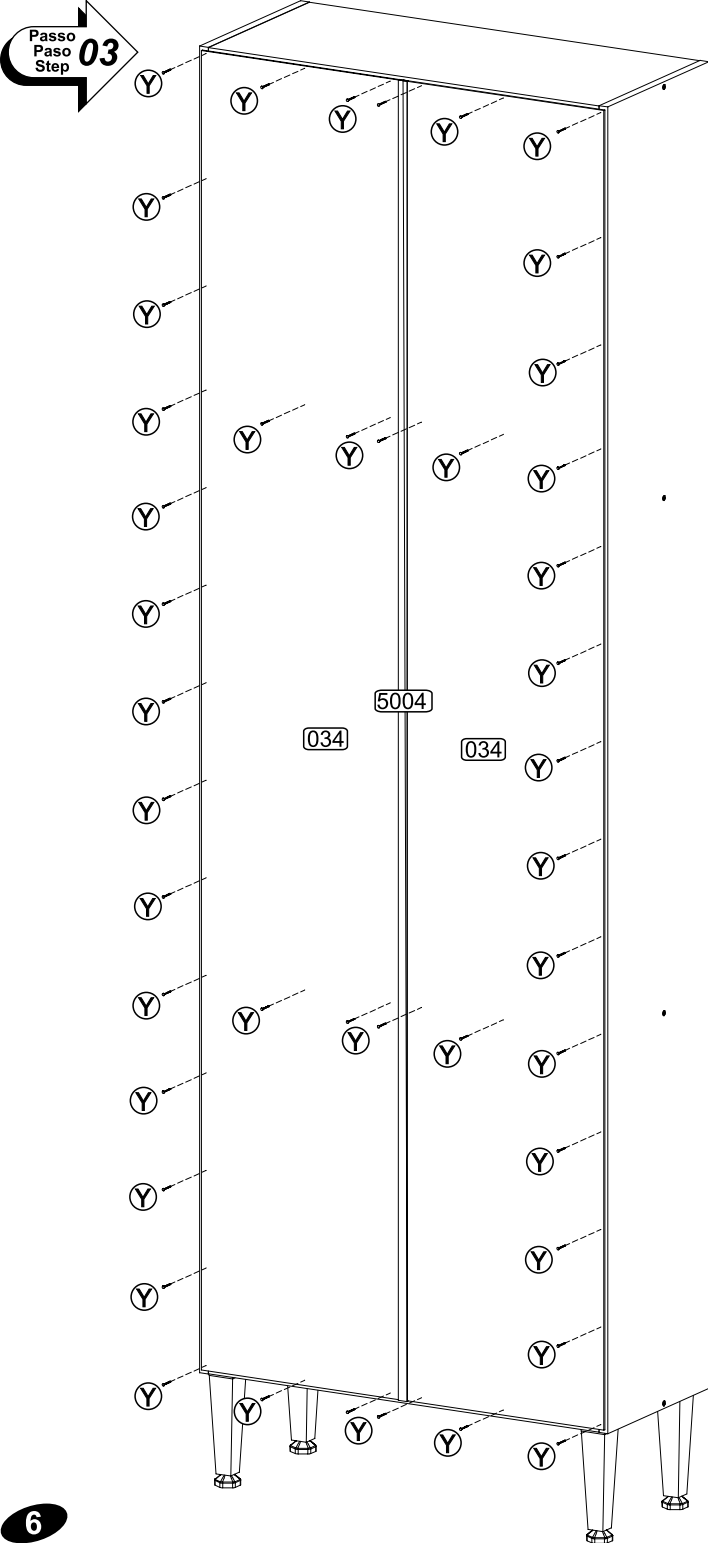

Passo
Paso
Step **03**

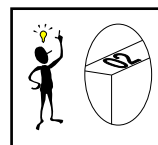

Senhor montador!
Informamos que a numeração das peças encontra-se no topo das mesmas conforme desenho acima.

Señor Armador!
Les informamos que la numeración de las piezas encuentranse arriba de las mismas, de acuerdo al modelo arriba.

Dear Assembler!
We inform you that the number of each piece is located on the top of it, according to the model shown above.

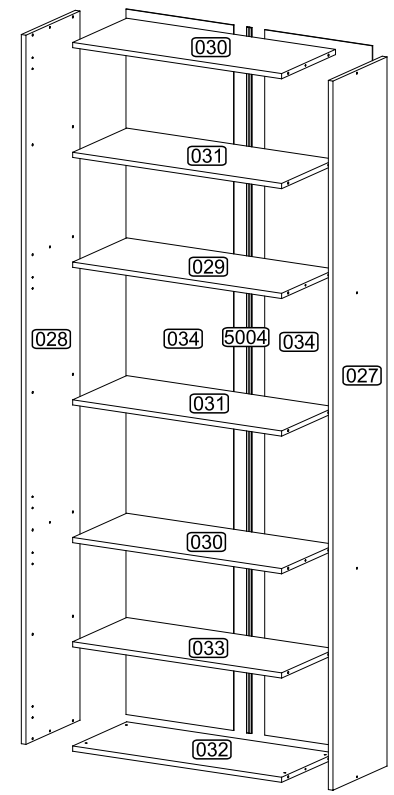
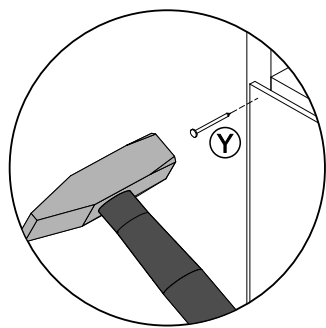

OPÇÃO 1

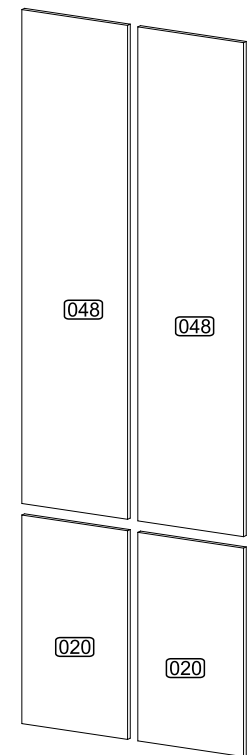

OPÇÃO 2

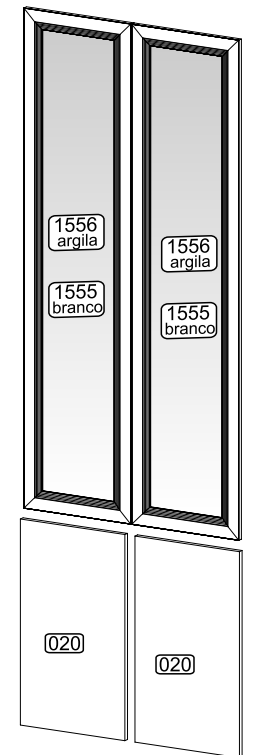

POR LISTA DE PEÇAS

Nº	DENOMINAÇÃO
020	- PORTA INFERIOR
027	- LATERAL DIREITA
028	- LATERAL ESQUERDA
029	- PRATELEIRA
030	- TAMPO / PRATELEIRA
031	- PRATELEIRA CAVILHA
032	- BASE
033	- PRATELEIRA INFERIOR
034	- COSTA
048	- PORTA MAIOR
5004	- PERFIL I
1555	- PORTA COM VIDRO BRANCA
1556	- PORTA COM VIDRO ARGILA

ESP LISTA DE PIEZAS

Nº	DENOMINACIÓN
020	- PUERTA INFERIOR
027	- LATERAL DERECHA
028	- LATERAL IZQUIERDA
029	- ESTANTE
030	- TAPA / ESTANTE
031	- ESTANTE TARUGO
032	- BASE
033	- ESTANTE INFERIOR
034	- RESPALDO
048	- PUERTA MAYOR
5004	- PERFIL I
1555	- PUERTA CON VIDRO BLANCO
1556	- PUERTA CON PERFIL ARGILA

ENG PART LIST

Nº	DESCRIPTION
020	- LOWER DOOR
027	- RIGHT SIDE
028	- LEFT SIDE
029	- SHELF
030	- TOP / SHELF
031	- BOLT SHELF
032	- BASE
033	- LOWER SHELF
034	- BACK
048	- LARGER DOOR
5004	- I PROFILE
1555	- DOOR WITH GLASS WHITE
1556	- DOOR WITH GLASS ARGILA

PRÉ-MONTAGEM / PRÉ-ARMADO / PRÉ-ASSEMBLAGE

Passo
Paso
Step **01**

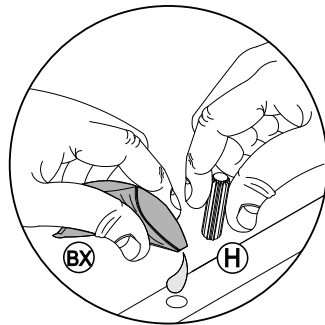
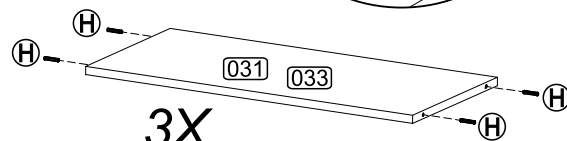
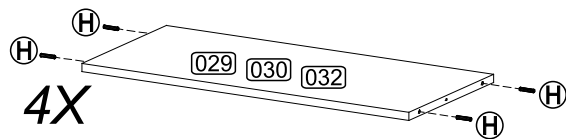
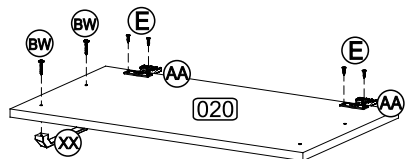
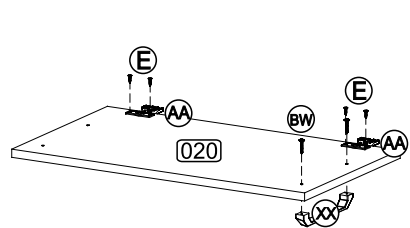
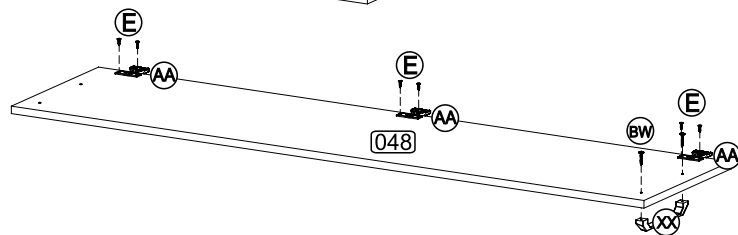
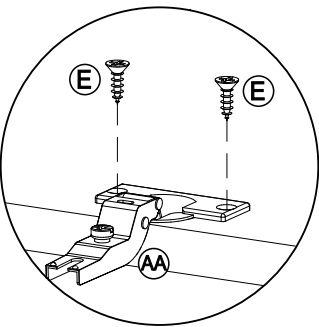
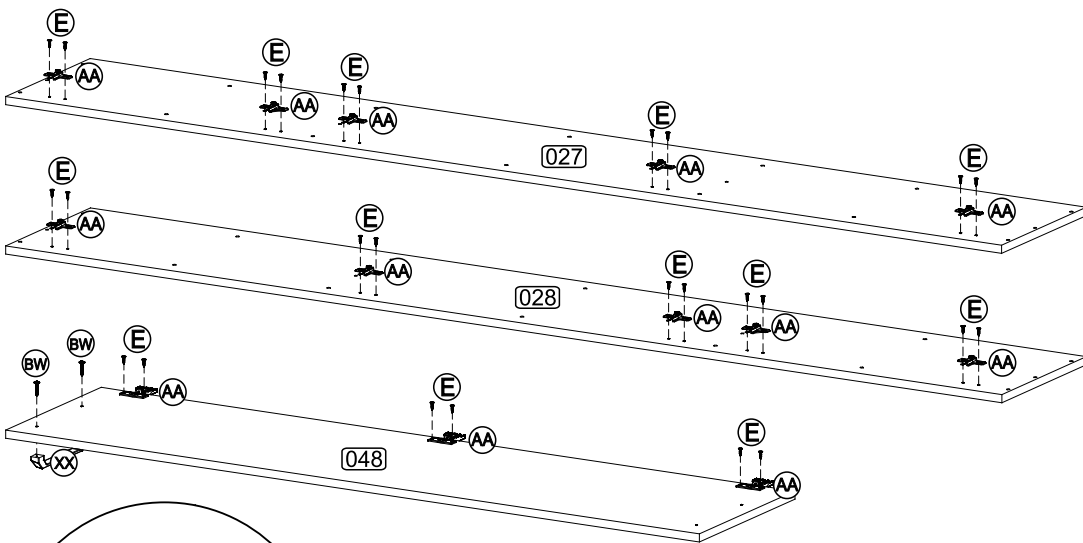

Passo
Paso
Step **02**

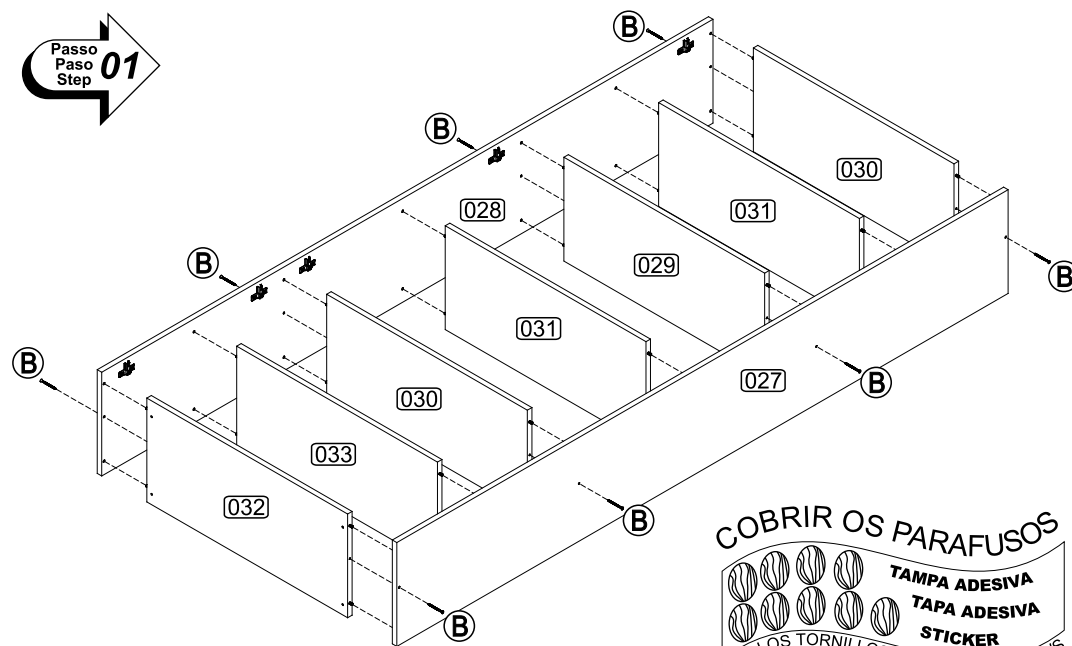

COBRIR OS PARAFUSOS
TAMPA ADESIVA
TAPA ADESIVA
STICKER
TAPA LOS TORNILLOS / COVER THE SCREWS

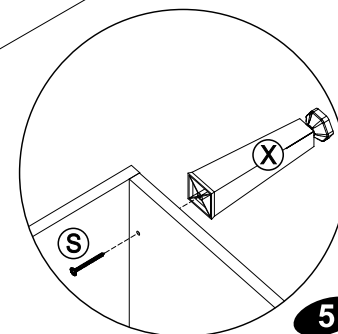
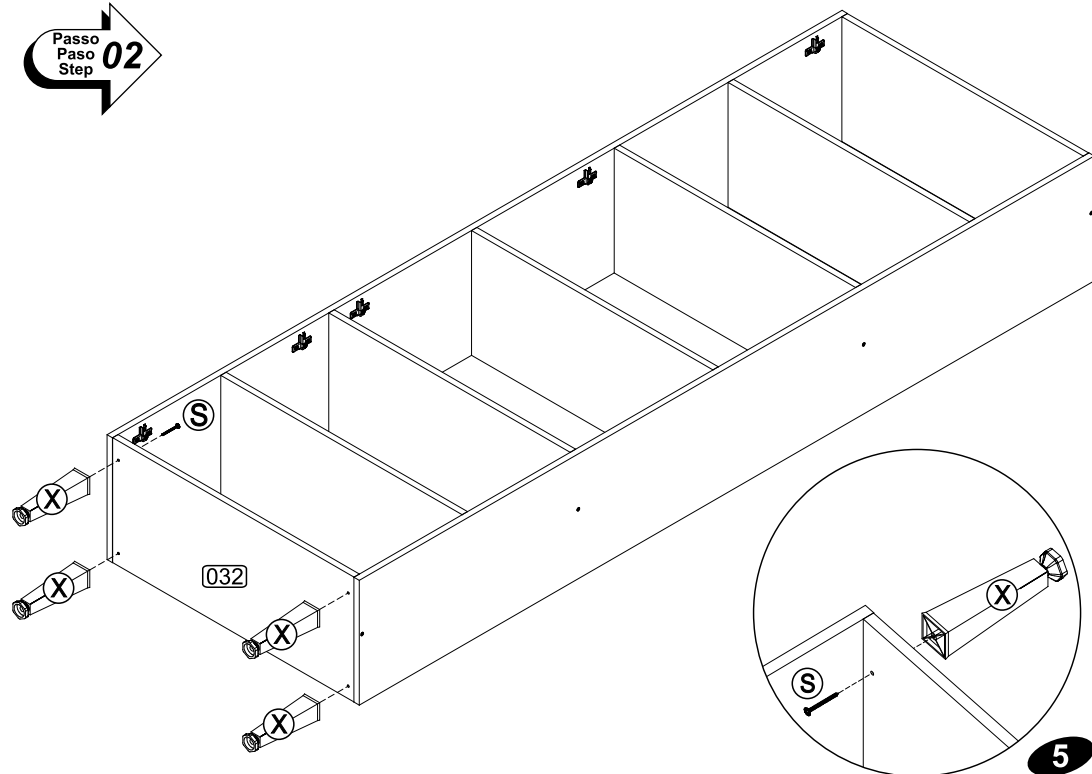

4

5

INSTRUÇÕES DE MONTAGEM INSTRUCCIONES DE ARMADO ASSEMBLY INSTRUCTIONS





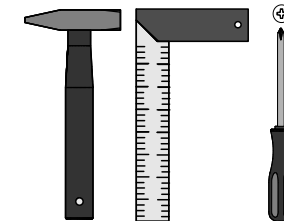
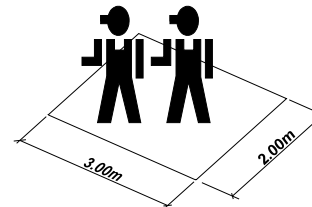
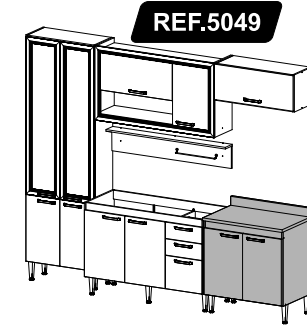
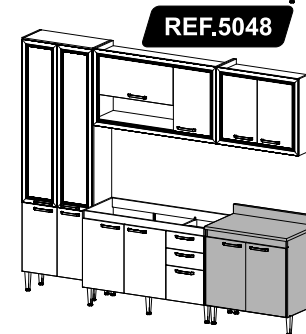
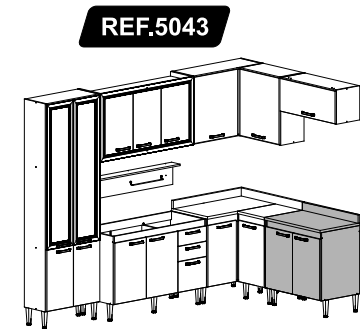
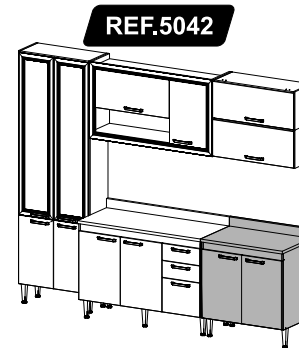
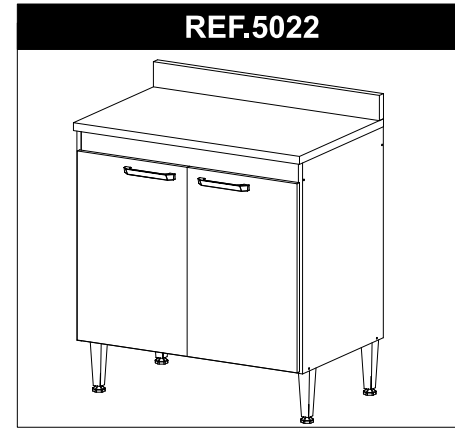
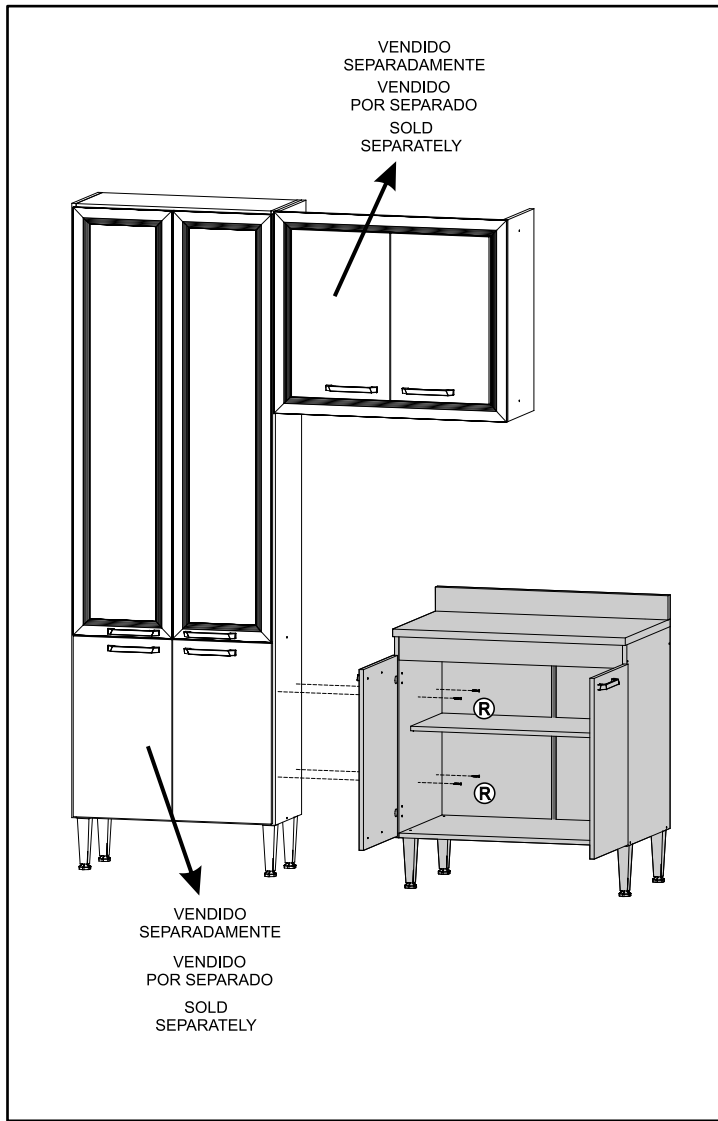
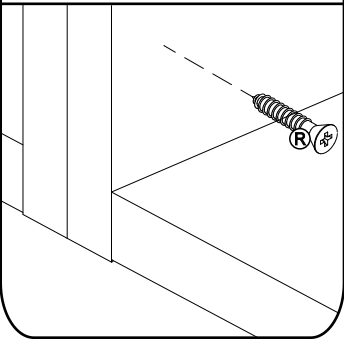





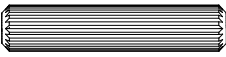

**REF.: 5022/5042/
5043/5048/5049**

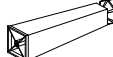
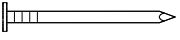
**União dos Módulos
Unión de los módulos
Pieces Junction**



MULTIMÓVEIS
decor

Rua Carlos Dreher Neto, 1918, Fone: (54) 2102 4000, FAX: (54) 2102 4050
CEP 95700-000 - BENTO GONÇALVES - RS - BRASIL
CNPJ: 00.349.443/0001-92
e-mail: multimoveis@multimoveis.com / site: www.multimoveis.com

A		Tampa Adesiva	12
B		Parafuso 4,5 x 50	11
E		Parafuso 3,5 x 14	16
H		Cavilha 6,0 x 30	04
R		Parafuso 4,0 x 25	04
S		Parafuso 5,0 X 45	04
X		Pé com Regulagem	04
Y		Prego 10 x 10	20
AA		Dobradiça	04
AT		Cantoneira Plástica	06
BW		Parafuso 3,5 x 25	04
BX		Bisnaga de Cola 5g	01
CC		3,5 X 12	16
DX		Suporte de Prateleira 5mm	04
XX		Puxador 160mm	02

Passo
Paso
Step
05

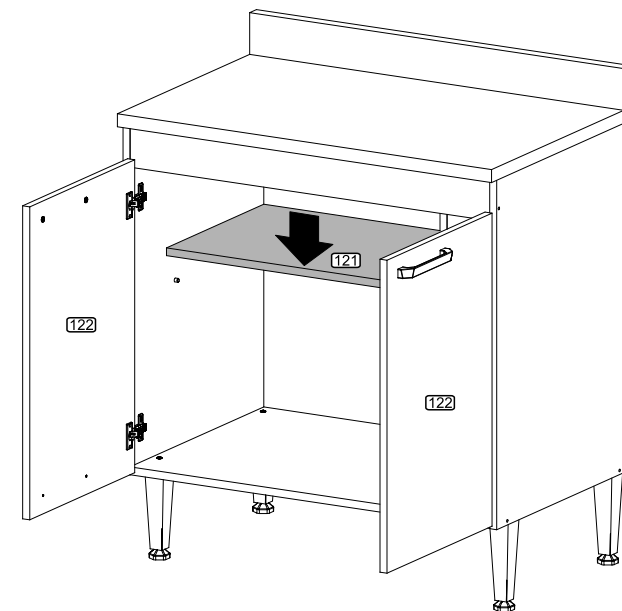
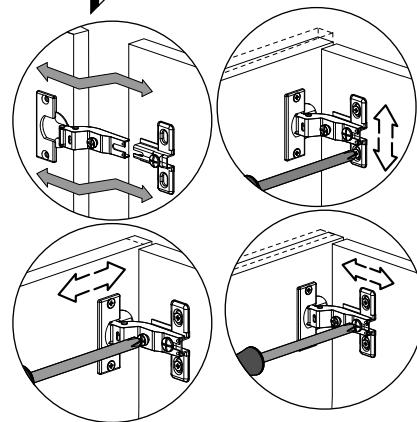

ATENÇÃO

Caso for utilizar no móvel o fogão cooktop, é necessário fazer um recorte no tampo, tomando como base as marcações existentes na parte inferior do tampo, conforme desenho abaixo.

ATENCIÓN

Si utilizar en el mueble el cooktop, es necesario hacer uno recorte en la parte superior, teniendo como base las marcaciones en la parte inferior de la tapa, de acuerdo con el dibujo abajo.

ATTENTION

In case to use the cooktop on the furniture, is necessary to make a cutting (open) on the top, based on the markings on the bottom, as illustrated below.

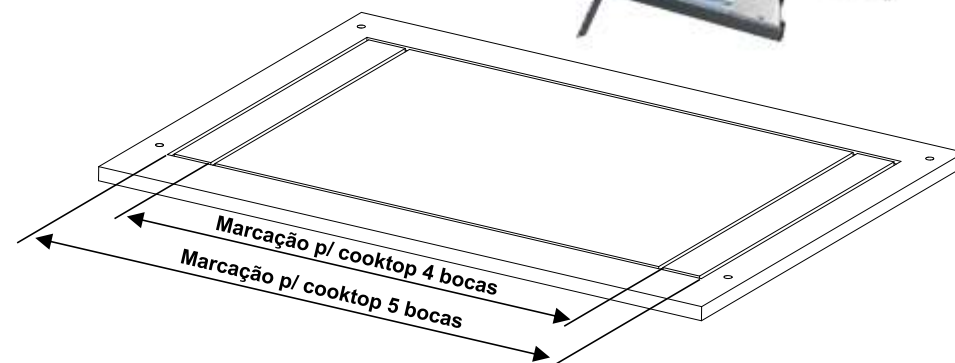



Utilizar a régua abaixo para medir as ferragens:

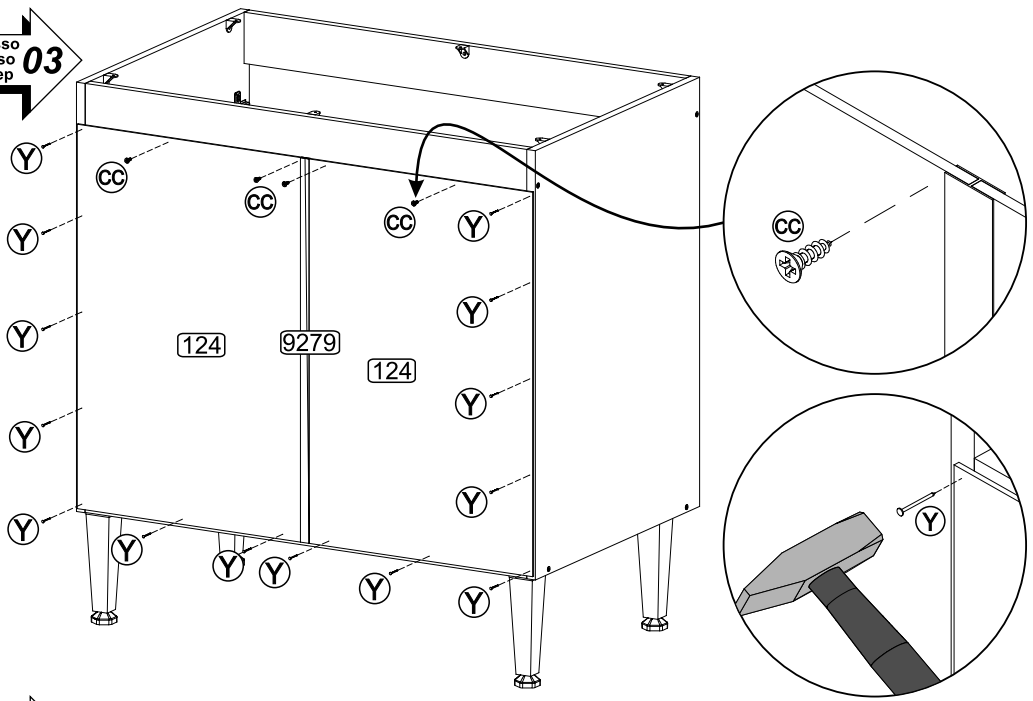

medidas em mm

Passo
Paso
Step **03**



  **Senhor montador!**
Informamos que a numeração das peças encontra-se no topo das mesmas conforme desenho acima.

Señor Armador!
Les informamos que la numeración de las piezas encuentranse arriba de las mismas, de acuerdo al modelo arriba.

Dear Assembler!
We inform you that the number of each piece is located on the top of it, according to the model shown above.

Passo
Paso
Step **04**

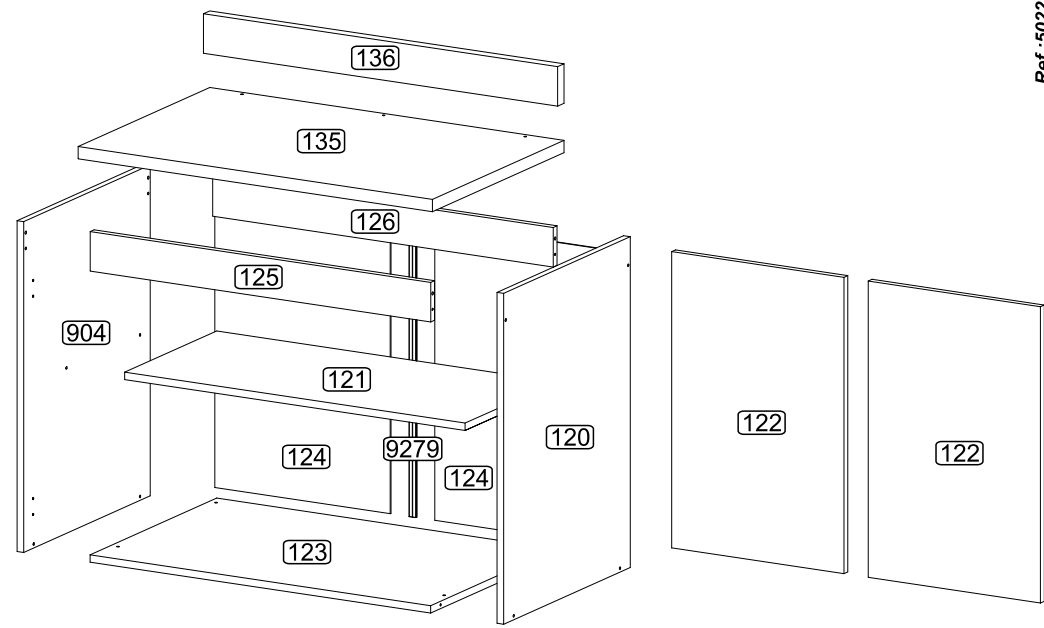
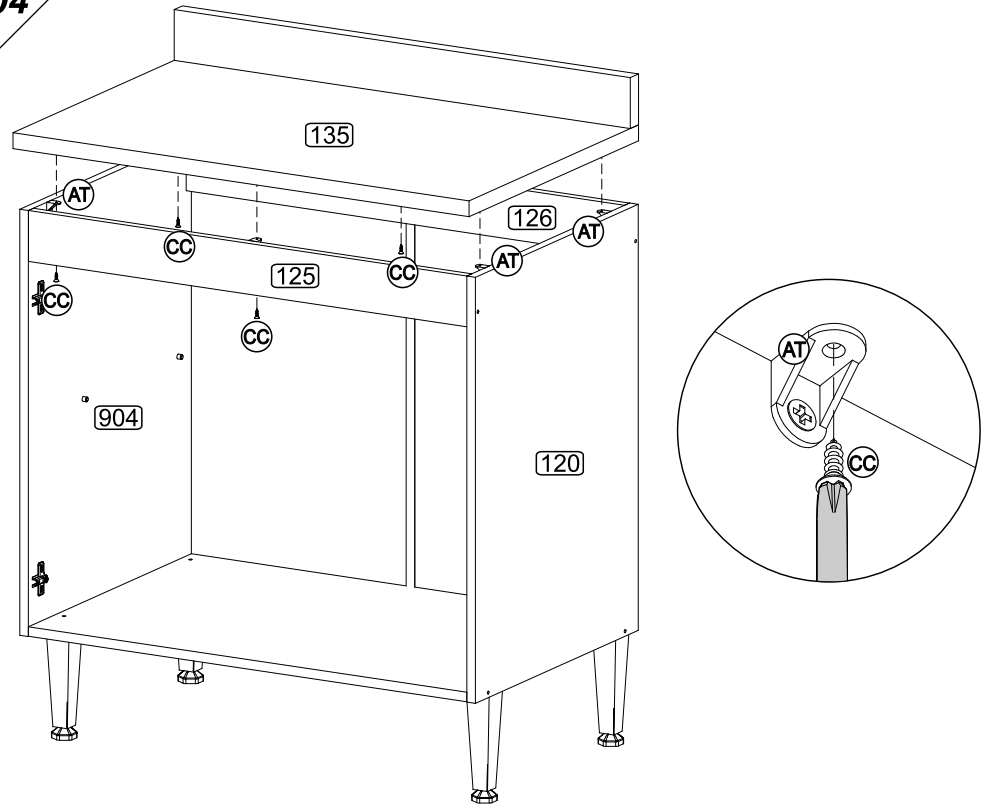

POR	LISTA DE PEÇAS	ESP	LISTA DE PIEZAS	ENG	PART LIST
N°	DENOMINAÇÃO	N°	DENOMINACIÓN	N°	DESCRIPTION
120	- LATERAL DIREITA	120	- LATERAL DERECHA	120	- RIGHT SIDE
121	- PRATELEIRA MOVEL	121	- ESTANTE MOVIL	121	- MOVABLE SHELF
122	- PORTA	122	- PUERTA	122	- DOOR
123	- BASE	123	- BASE	123	- BASE
124	- COSTA	124	- RESPALDO	124	- BACK
125	- TRAVESSA	125	- TRAVIESA	125	- CROSS BAR
126	- TRAVESSA TRASEIRA	126	- TRAVIESA TRASERA	126	- BACK BEAM
135	- TAPA	135	- TAPA	135	- TOP
136	- MOLDURA	136	- MOLDURA	136	- FRAME
904	- LATERAL ESQUERDA	904	- LATERAL IZQUIERDA	904	- LEFT SIDE
9279	- PERFIL I	9279	- PERFIL I	9279	- I PROFILE

PRÉ-MONTAGEM / PRÉ-ARMADO / PRÉ-ASSEMBLAGE

**Passo
Paso
Step** **01**

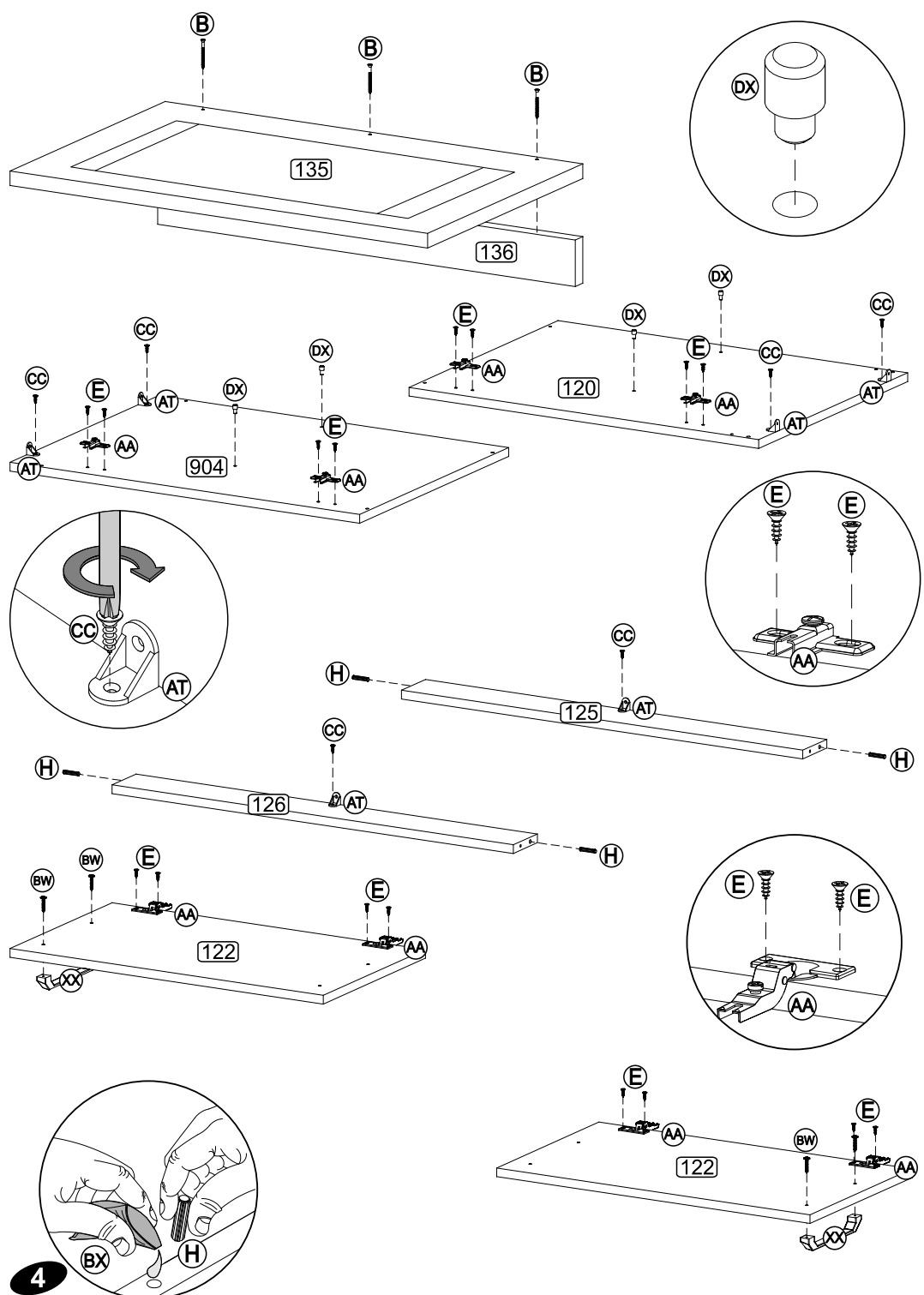

**Passo
Paso
Step** **02**

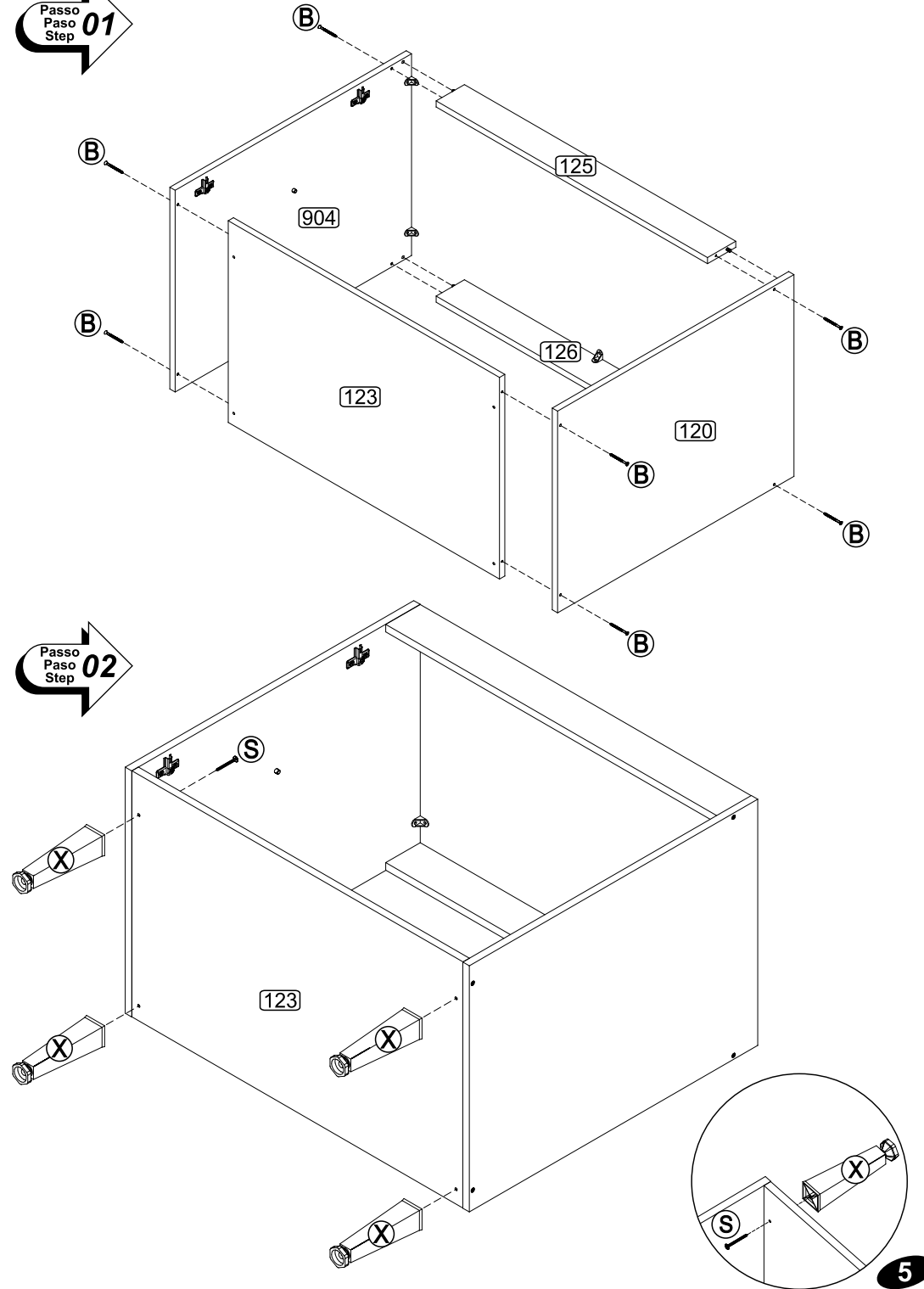

Fixação na Parede/Montaje en la Pared
Wall Assembly

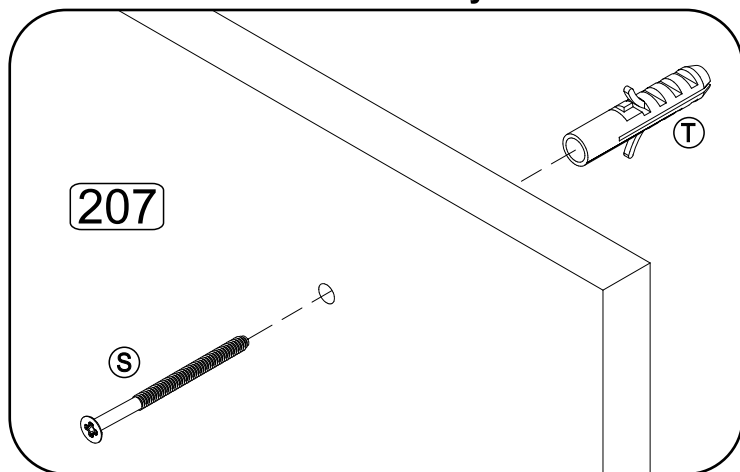

COBRIR OS PARAFUSOS
TAMPA ADESIVA
TAPA ADESIVA
STICKER
TAPA LOS TORNILLOS / COVER THE SCREWS



MULTIMÓVEIS
decor

Rua Carlos Dreher Neto, 1918, Fone: (54) 2102 4000, FAX: (54) 2102 4050
CEP 95700-000 - BENTO GONÇALVES - RS - BRASIL
CNPJ: 00.349.443/0001-92
e-mail: multimoveis@multimoveis.com / site: www.multimoveis.com

INSTRUÇÕES DE MONTAGEM
INSTRUCCIONES DE ARMADO
ASSEMBLY INSTRUCTIONS

REF.5024

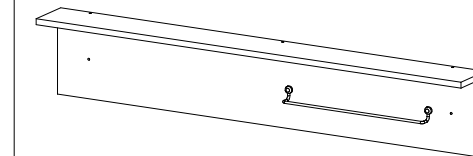

REF.: 5024/5043/
5049/5144/5146/
5153/5063/5064

REF.5043

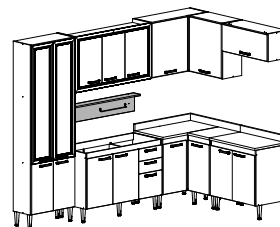

REF.5049

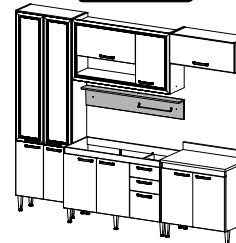

REF.5144

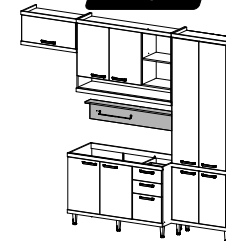

REF.5146

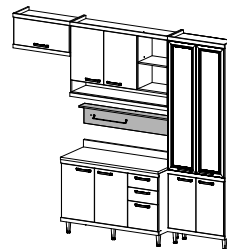

REF.5153

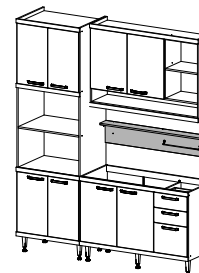



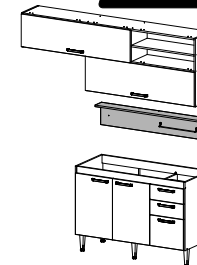

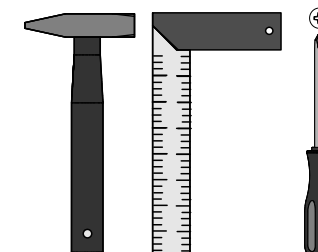
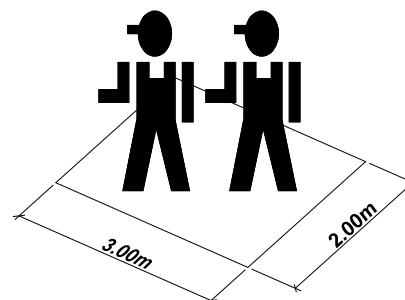
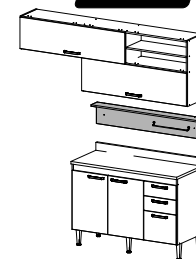

REF.5063





REF.5064



A		Tampa Adesiva	05
B		Parafuso 4,5 x 50	03
E		Parafuso 3,5 x 14	02
H		Cavilha 6,0 x 30	03
S		Parafuso 5,5 x 50	02
T		Bucha Ø8mm	02
X		Toalheiro 400mm	01

Utilizar a régua abaixo para medir as ferragens:



	<p>Señor montador! Informamos que a numeração das peças encontra-se no topo das mesmas conforme desenho acima.</p>		<p>Señor Armador! Les informamos que la numeración de las piezas encuentranse arriba de las mismas, de acuerdo al modelo arriba.</p>		<p>Dear Assembler! We inform you that the number of each piece is located on the top of it, according to the model shown above.</p>
---	--	---	--	---	---

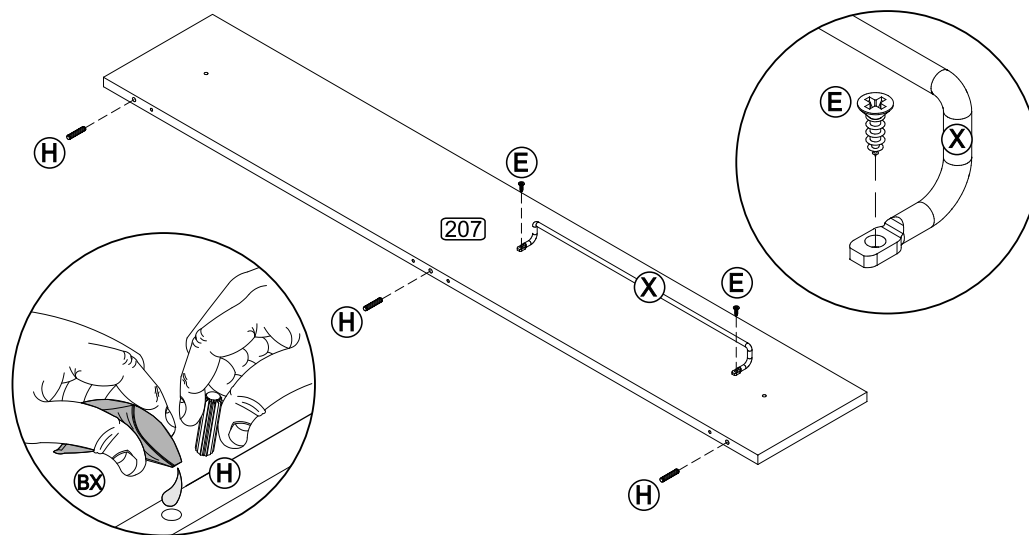

Passo
Paso
Step
01

COBRIR OS PARAFUSOS
TAMPA ADESIVA
TAPA ADESIVA
STICKER
TAPA LOS TORNILLOS / COVER THE SCREWS

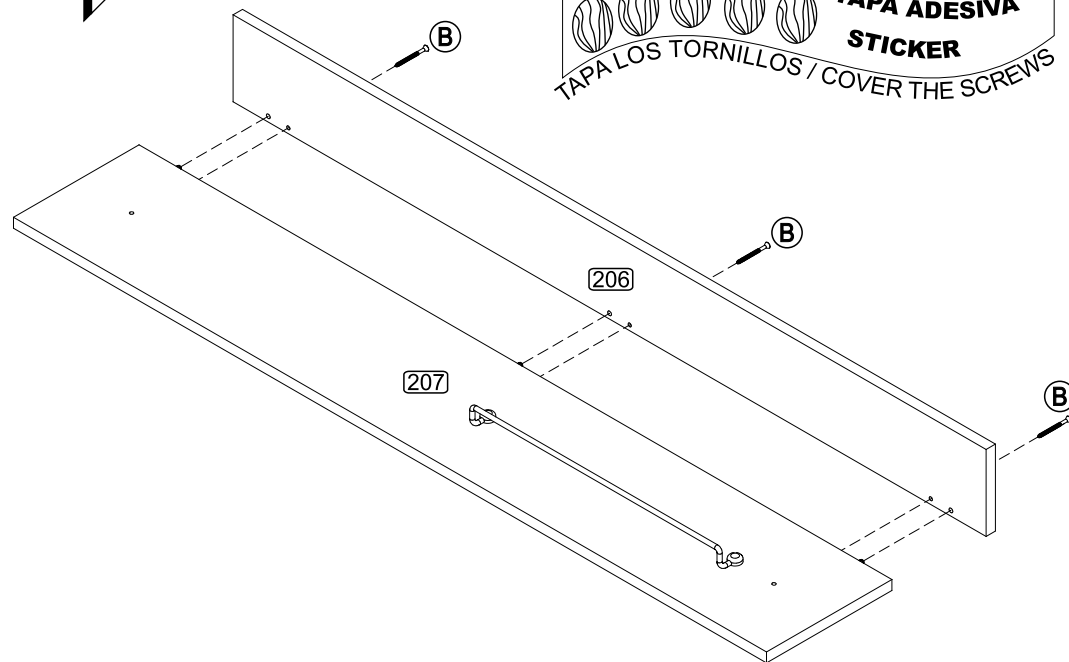

POR	LISTA DE PEÇAS	ESP	LISTA DE PIEZAS	ENG	PART LIST
Nº	DENOMINAÇÃO	Nº	DENOMINACIÓN	Nº	DESCRIPTION
206	TAMPO	206	TAPA	206	TOP
207	PAINEL	207	PANEL	207	PANEL

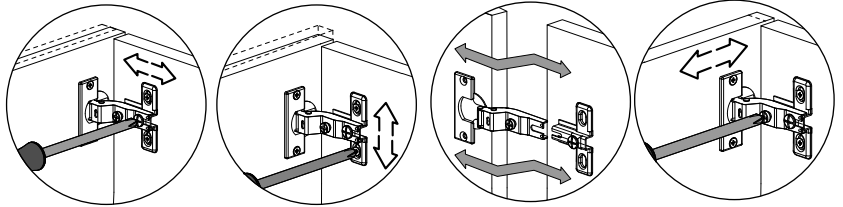
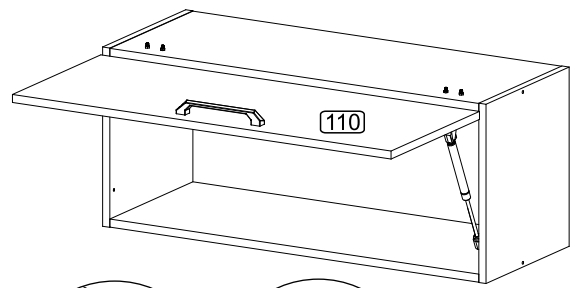

Fixação na Parede
Montaje en la Pared
Wall Assembly

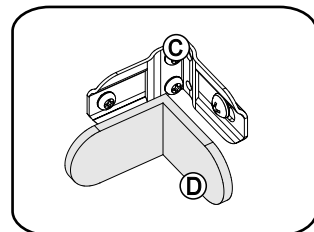
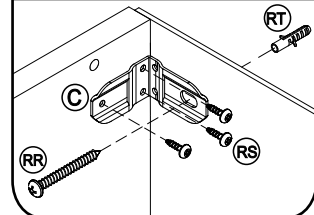

União dos Módulos
Unión de los módulos
Pieces Junction

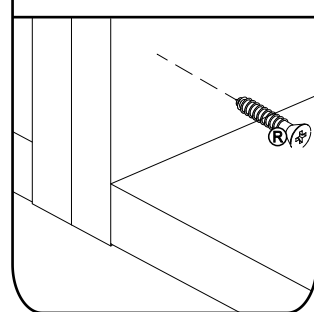

VENDIDO SEPARADAMENTE
VENDIDO POR SEPARADO
SOLD SEPARATELY

MULTIMÓVEIS
decor

Rua Carlos Dreher Neto, 1918, Fone: (54) 2102 4000, FAX: (54) 2102 4050
CEP 95700-000 - BENTO GONÇALVES - RS - BRASIL
CNPJ: 00.349.443/0001-92
e-mail: multimoveis@multimoveis.com / site: www.multimoveis.com

INSTRUÇÕES DE MONTAGEM
INSTRUCCIONES DE ARMADO
ASSEMBLY INSTRUCTIONS

REF.: 5025/5042/5043
5044/5047/5049/5054

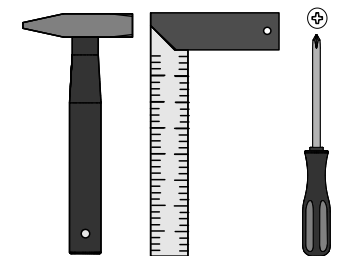
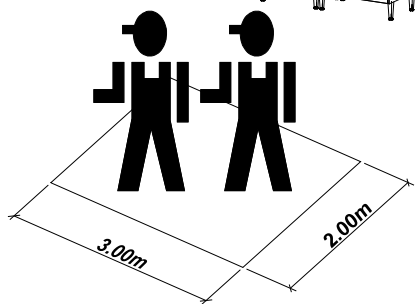
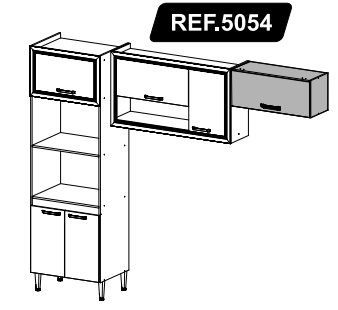
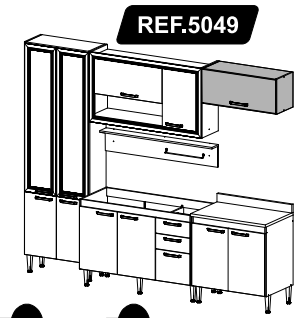
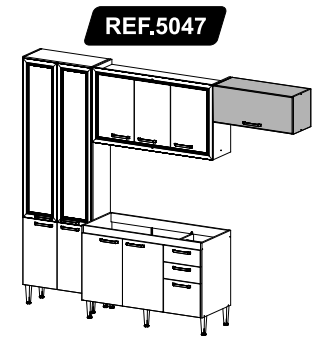
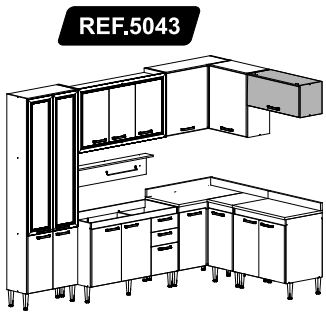
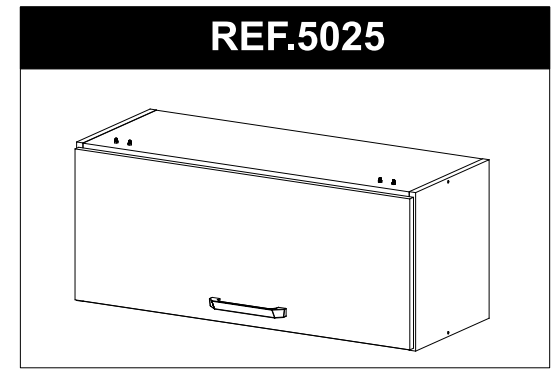
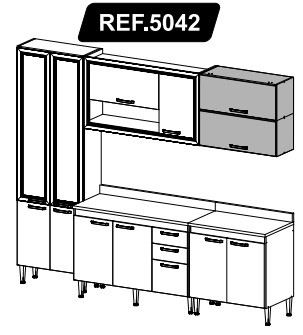

LISTA DE FERRAGENS / LISTA DE MATERIALES / HARDWARE LIST

PRÉ-MONTAGEM / PRÉ-ARMADO / PRÉ-ASSEMBLAGE

Ref.:5025 - 27 / Setembro / 2016- Rev. 03

A		Tampa Adesiva	08
B		Parafuso 4,5 x 50	04
C		Suporte Aéreo	02
D		Capa p/ Suporte Aéreo	02
E		Parafuso 3,5 x 14	04
H		Cavilha 6,0 x 30	08
R		Parafuso 4,0 x 25	04
Y		Prego 10 x 10	15
AA		Dobradiça	02

BW		Parafuso 3,5 x 25	02
BX		Bisnaga de Cola 5g	01
CE		Parafuso MAQ 5/32X1	04
CD		Aruela Lisa	04
CF		Porca sexavada 5/32	04
CJ		Pistão	01
XX		Puxador 160mm	01
RR		5,0 x 45	02
RS		3,5 x 14	06
RT		Bucha Ø8mm	02

Senhor montador!
Informamos que a numeração das peças encontra-se no topo das mesmas conforme desenho acima.

Señor Armador!
Les informamos que la numeración de las piezas encuentranse arriba de las mismas, de acuerdo al modelo arriba.

Dear Assembler!
We inform you that the number of each piece is located on the top of it, according to the model shown above.

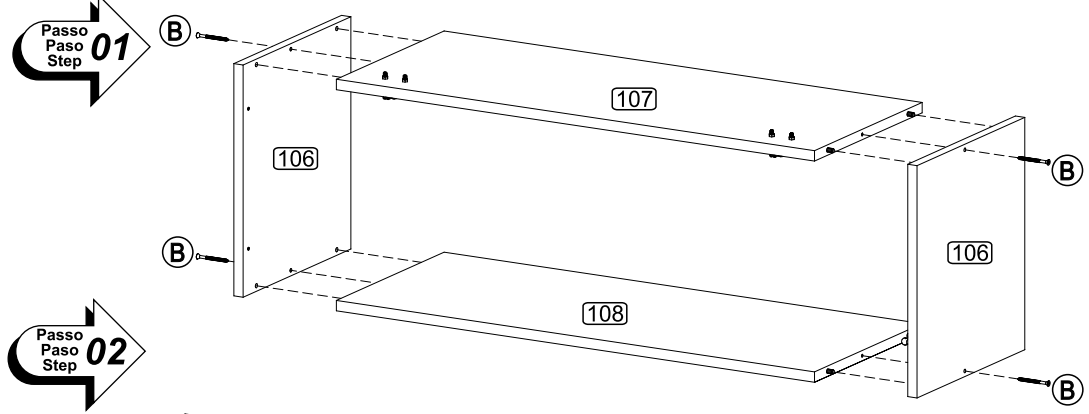
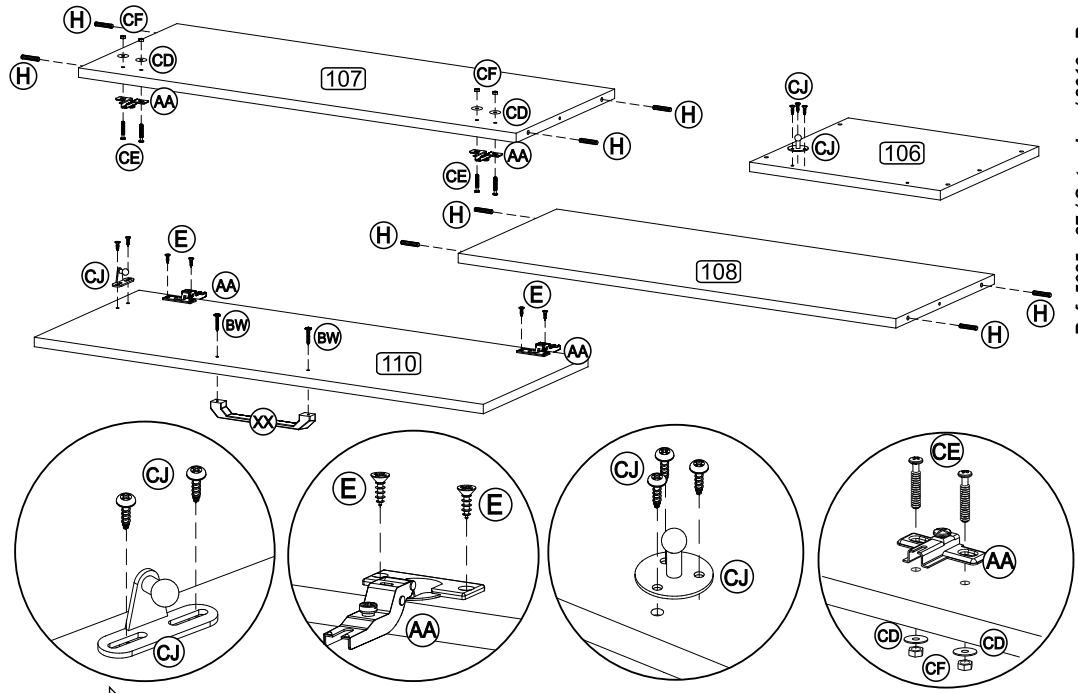
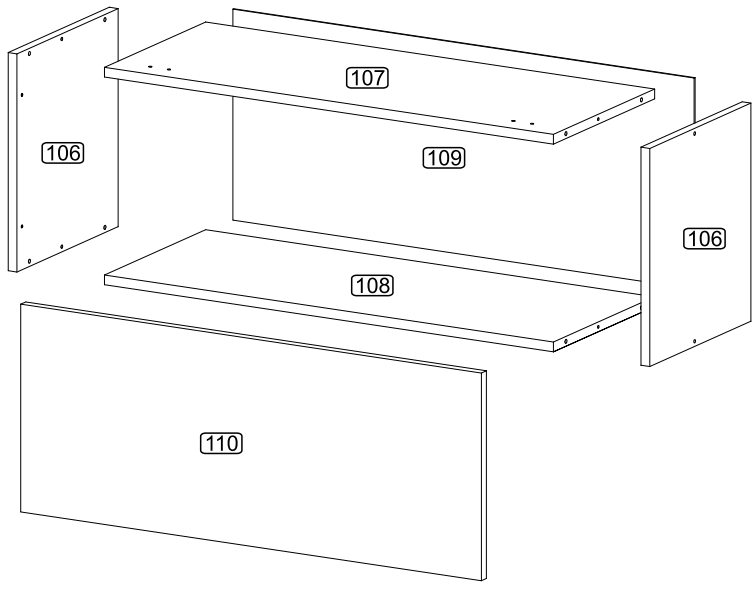

POR	LISTA DE PEÇAS	ESP	LISTA DE PIEZAS	ENG	PART LIST
Nº	DENOMINAÇÃO	Nº	DENOMINACIÓN	Nº	DESCRIPTION
106	- LATERAL	106	- LATERAL	106	- SIDE
107	- TAMPO	107	- TAPA	107	- TOP
108	- BASE	108	- BASE	108	- BASE
109	- COSTA	109	- RESPALDO	109	- BACK
110	- PORTA	110	- PUERTA	110	- DOOR

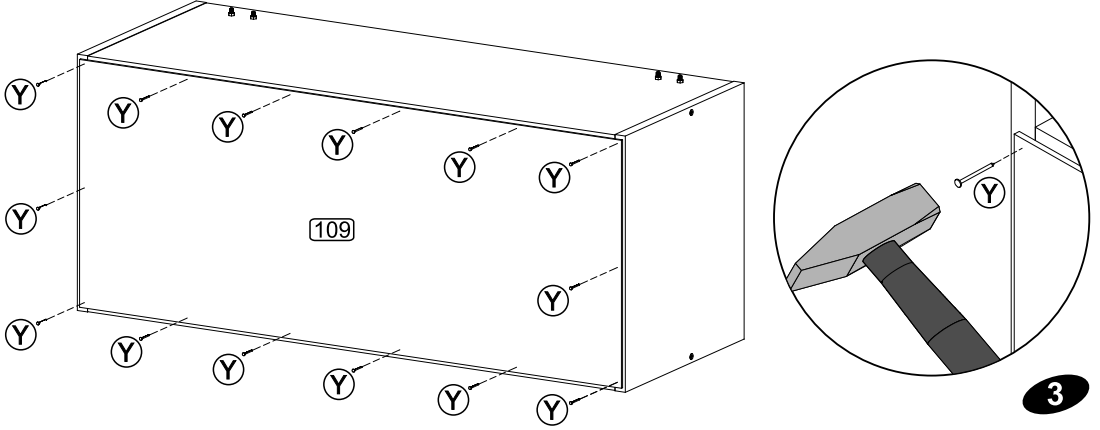

FIXAÇÃO DO TAMPO E RODATAMPO (TAMPO OPCIONAL)

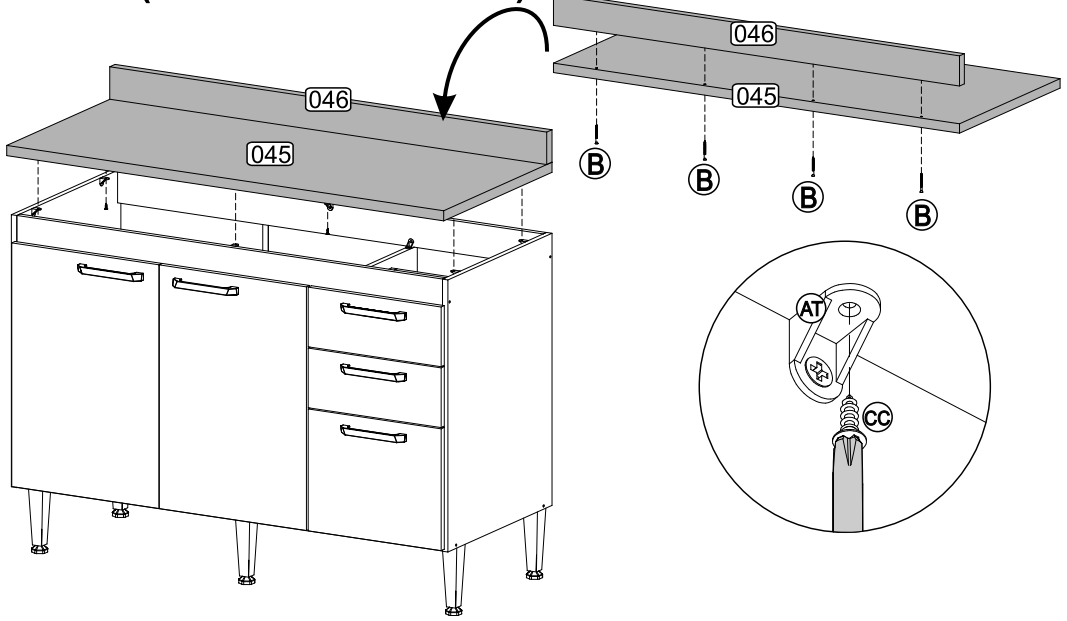

INSTRUÇÕES DE MONTAGEM INSTRUCCIONES DE ARMADO ASSEMBLY INSTRUCTIONS

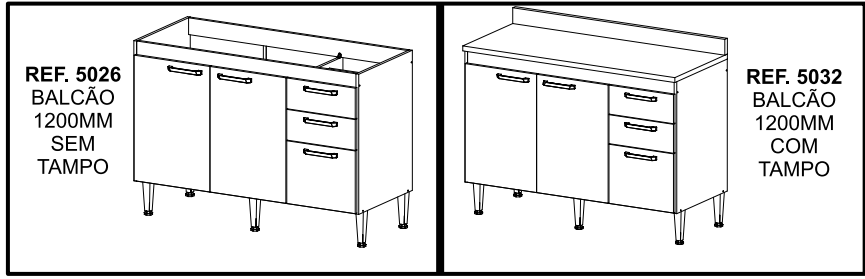

REF.: 5026/5032/5042/5043/
5044/5047/5048/5049/5055/
5056/5057/5058/5059/5060
5061/5062/5063/5064

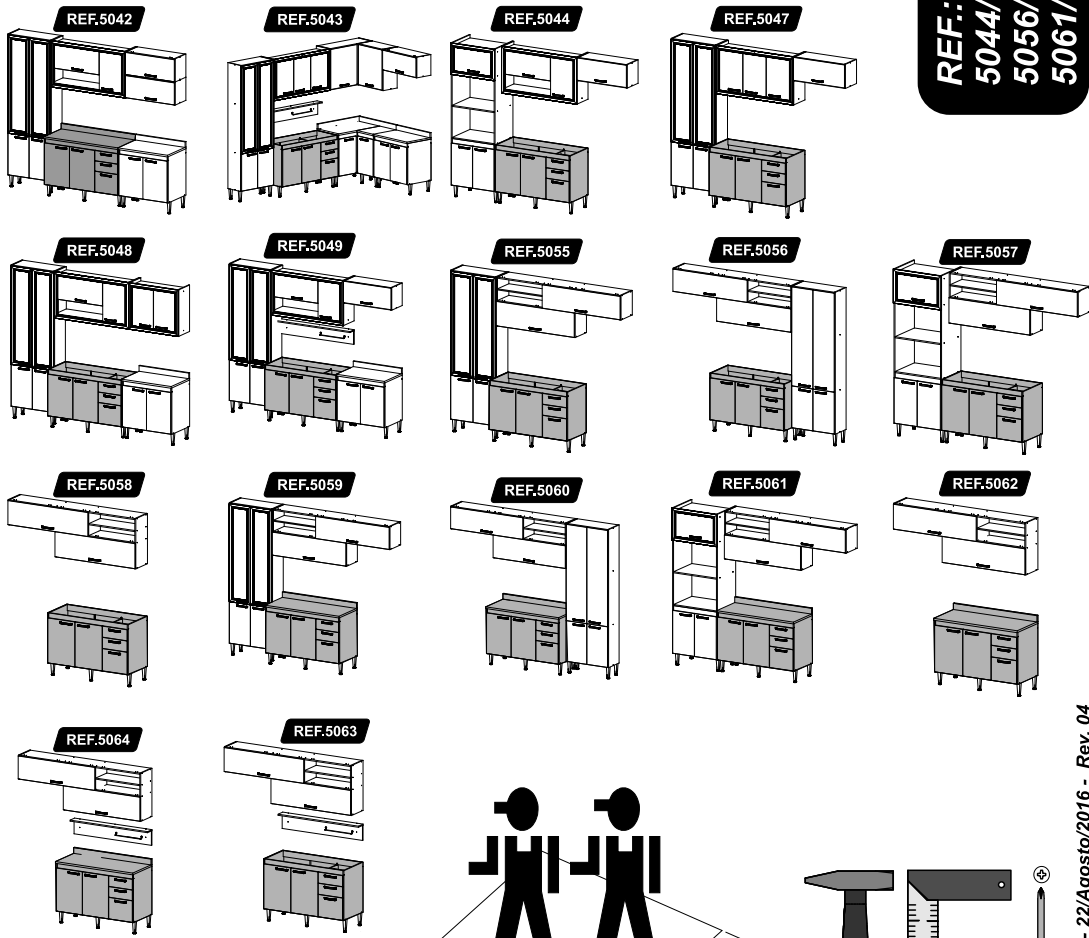

União dos Módulos
Unión de los módulos
Pieces Junction

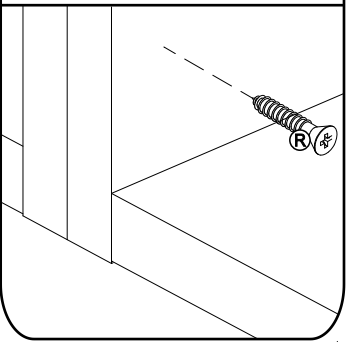

MULTIMÓVEIS
decor

Rua Carlos Dreher Neto, 1918, Fone: (54) 2102 4000, FAX: (54) 2102 4050
CEP 95700-000 - BENTO GONÇALVES - RS - BRASIL
CNPJ: 00.349.443/0001-92
e-mail: multimoveis@multimoveis.com / site: www.multimoveis.com

VENDIDO SEPARADAMENTE
VENDIDO POR SEPARADO
SOLD SEPARATELY

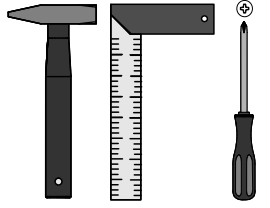
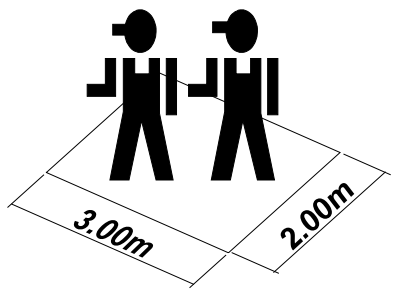

LISTA DE FERRAGENS / LISTA DE MATERIALES / HARDWARE LIST

Utilizar a régua abaixo para medir as ferragens:

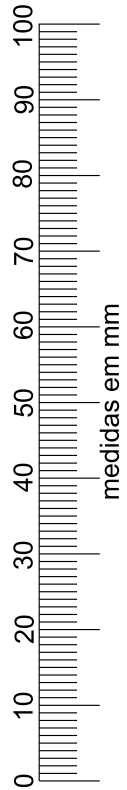

A		Tampa Adesiva	10
B		Parafuso 4,5 x 50	10
D		Parafuso 4,0 x 35	12
E		Parafuso 3,5 x 14	16
H		Cavilha 6,0 x 30	16
R		Parafuso 4,0 x 25	04
S		Parafuso 5,0 X 45	05
X		Pé com Regulagem	05
Y		Prego 10 x 10	40
AA		Dobradiça	04
AE		Fixador de Costas	05
AT		Cantoneira Plástica	10
BW		Parafuso 3,5 x 25	10
BX		Bisnaga de Cola 5g	01
CA		Corrediça	03
CC		3,5 X 12	50
DX		Suporte de Prateleira 5mm	04
XX		Puxador 160mm	05

Passo
Paso
Step
04

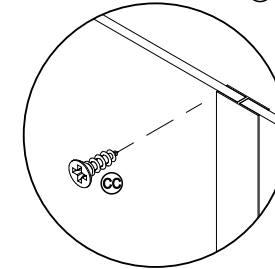
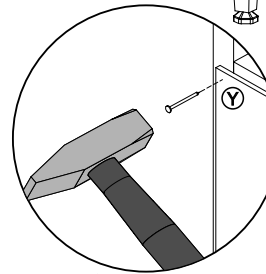
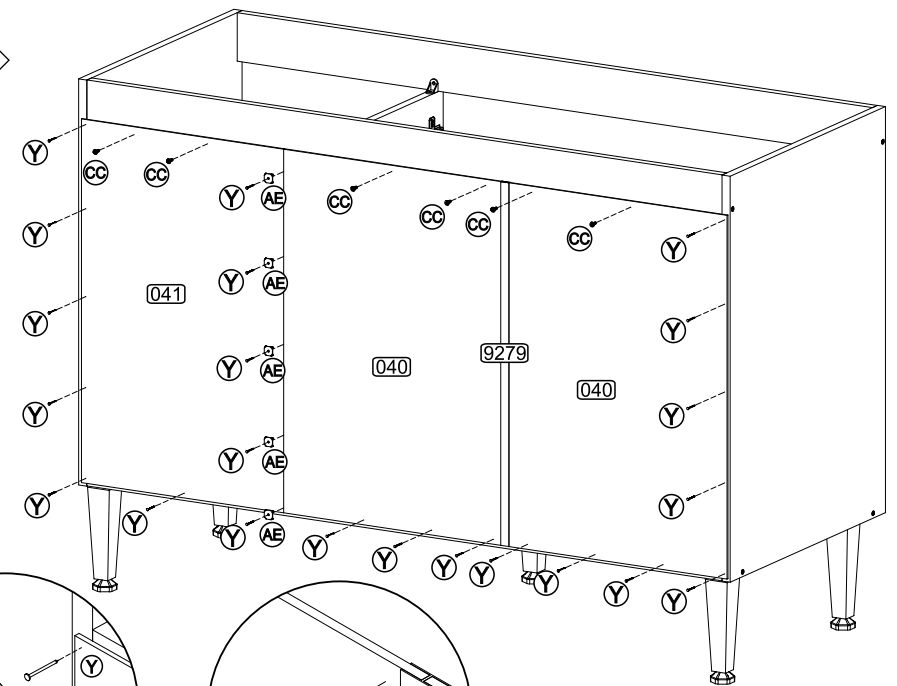

Passo
Paso
Step
05

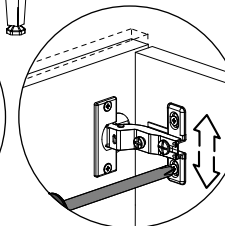
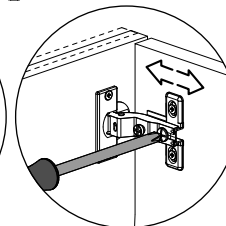
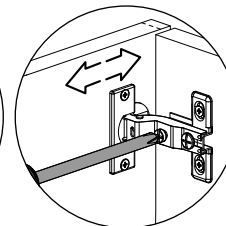
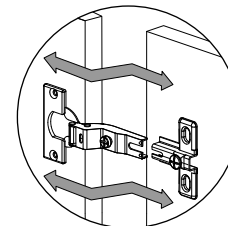
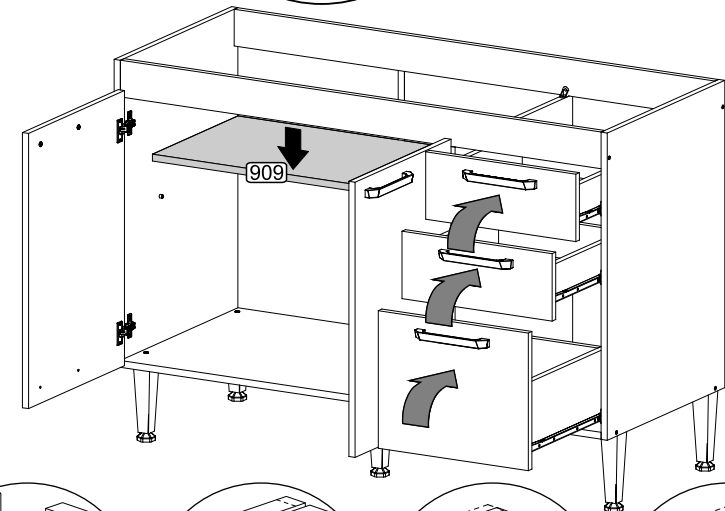

SOMENTE PARA A REF. 5032

B		Parafuso 4,5 x 50	04
AT		Cantoneira Plástica	06
CC		3,5 X 12	12

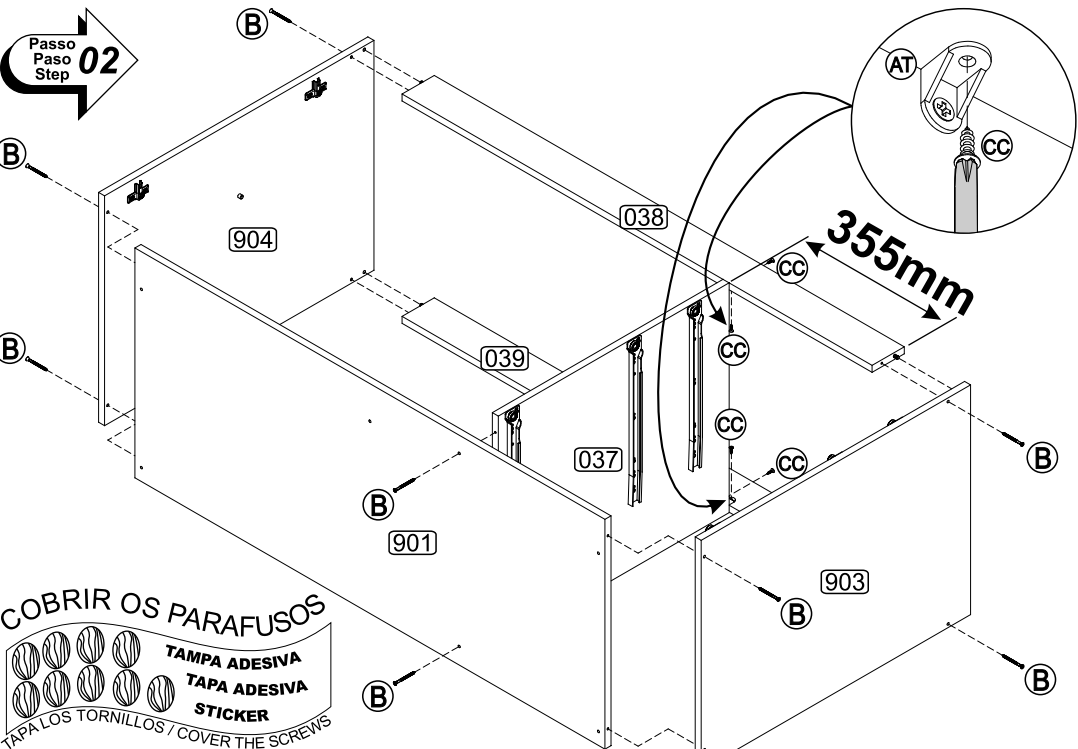

COBRIR OS PARAFUSOS
TAMPA ADESIVA
TAPA ADESIVA
STICKER
 TAPA LOS TORNILLOS / COVER THE SCREWS

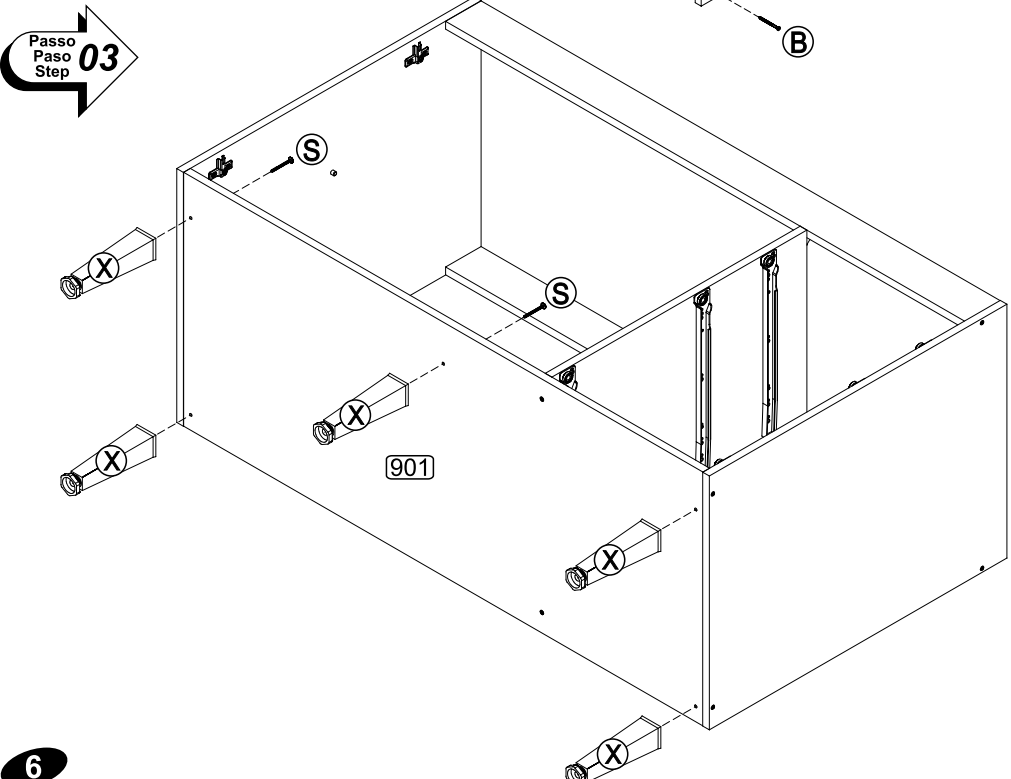

Senhor montador!
 Informamos que a numeração das peças encontra-se no topo das mesmas conforme desenho acima.

Señor Armador!
 Les informamos que la numeración de las piezas encuentranse arriba de las mismas, de acuerdo al modelo arriba.

Dear Assembler!
 We inform you that the number of each piece is located on the top of it, according to the model shown above.

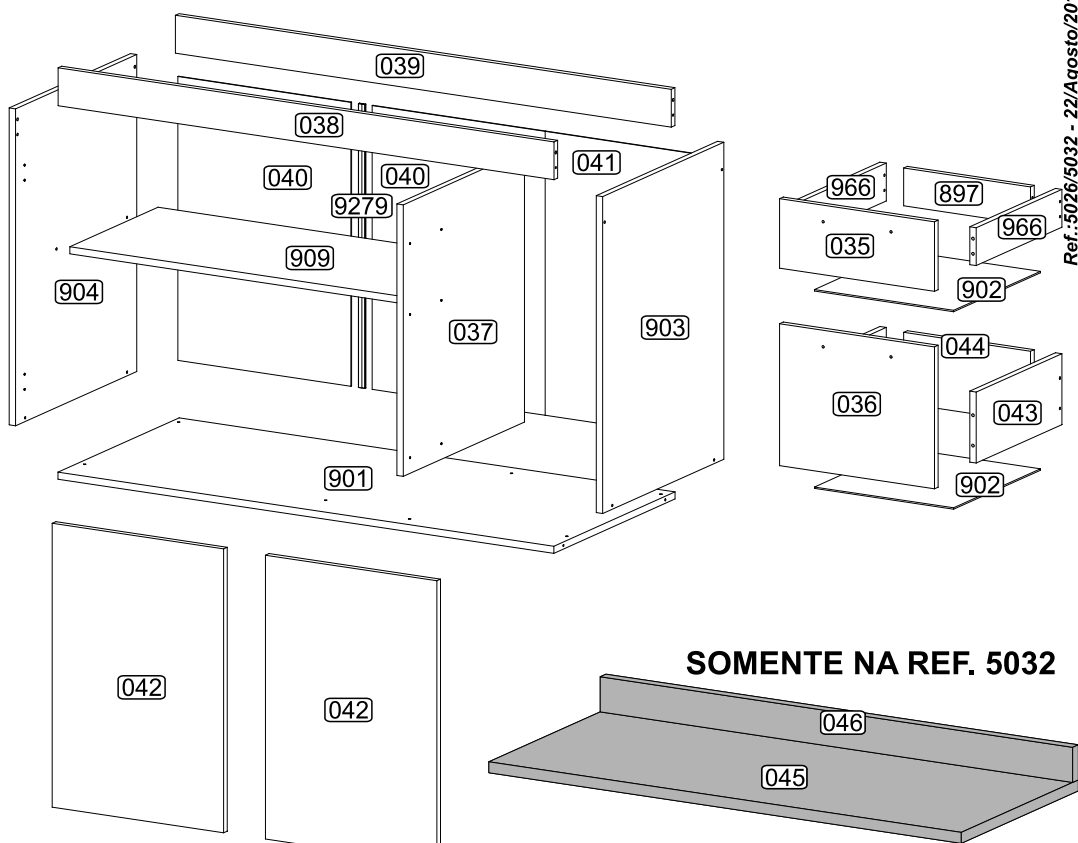

SOMENTE NA REF. 5032

POR	LISTA DE PEÇAS	ESP	LISTA DE PIEZAS	ENG	PART LIST
N°	DENOMINAÇÃO	N°	DENOMINACIÓN	N°	DESCRIPTION
035	FRENTE GAVETA MENOR	035	FRENTE CAJÓN MENOR	035	SMALLER FRONT DRAWER
036	FRENTE GAVETA MAIOR	036	FRENTE CAJÓN MAIOR	036	LARGER FRONT DRAWER
037	DIVISÃO	037	DIVISIÓN	037	DIVISION
038	TRAVESSA	038	TRAVIESA	038	CROSS BAR
039	TRAVESSA TRASEIRA	039	TRAVIESA TRASERA	039	BACK BEAM
040	COSTA MAIOR	040	RESPALDO MAIOR	040	LARGER BACK
041	COSTA MENOR	041	RESPALDO MENOR	041	SMALLER BACK
042	PORTA	042	PUERTA	042	DOOR
043	LATERAL GAVETA MAIOR	043	LATERAL CAJÓN MAIOR	043	LARGER DRAWER SIDE
044	COSTA GAVETA MAIOR	044	RESPALDO CAJÓN MAIOR	044	LARGER DRAWER BACK
897	COSTA DE GAVETA	897	RESPALDO CAJÓN	897	DRAWER BACK
901	BASE	901	BASE	901	BASE
902	FUNDO DE GAVETA	902	FONDO CAJÓN	902	BOTTOM DRAWER
903	LATERAL DIREITA	903	LATERAL DERECHA	903	RIGHT SIDE
904	LATERAL ESQUERDA	904	LATERAL IZQUIERDA	904	LEFT SIDE
909	PRATELEIRA MOVEL	909	ESTANTE MOVIL	909	MOVABLE SHELF
9279	PERFIL I	9279	PERFIL I	9279	I PROFILE
966	LATERAL GAVETA	966	LATERAL CAJÓN	966	DRAWER SIDE

SOMENTE PARA REF. 5032

045	TAMPO	045	TAPA	045	TOP
046	MOLDURA	046	MOLDURA	046	FRAME

PRÉ-MONTAGEM / PRÉ-ARMADO / PRÉ-ASSEMBLAGE

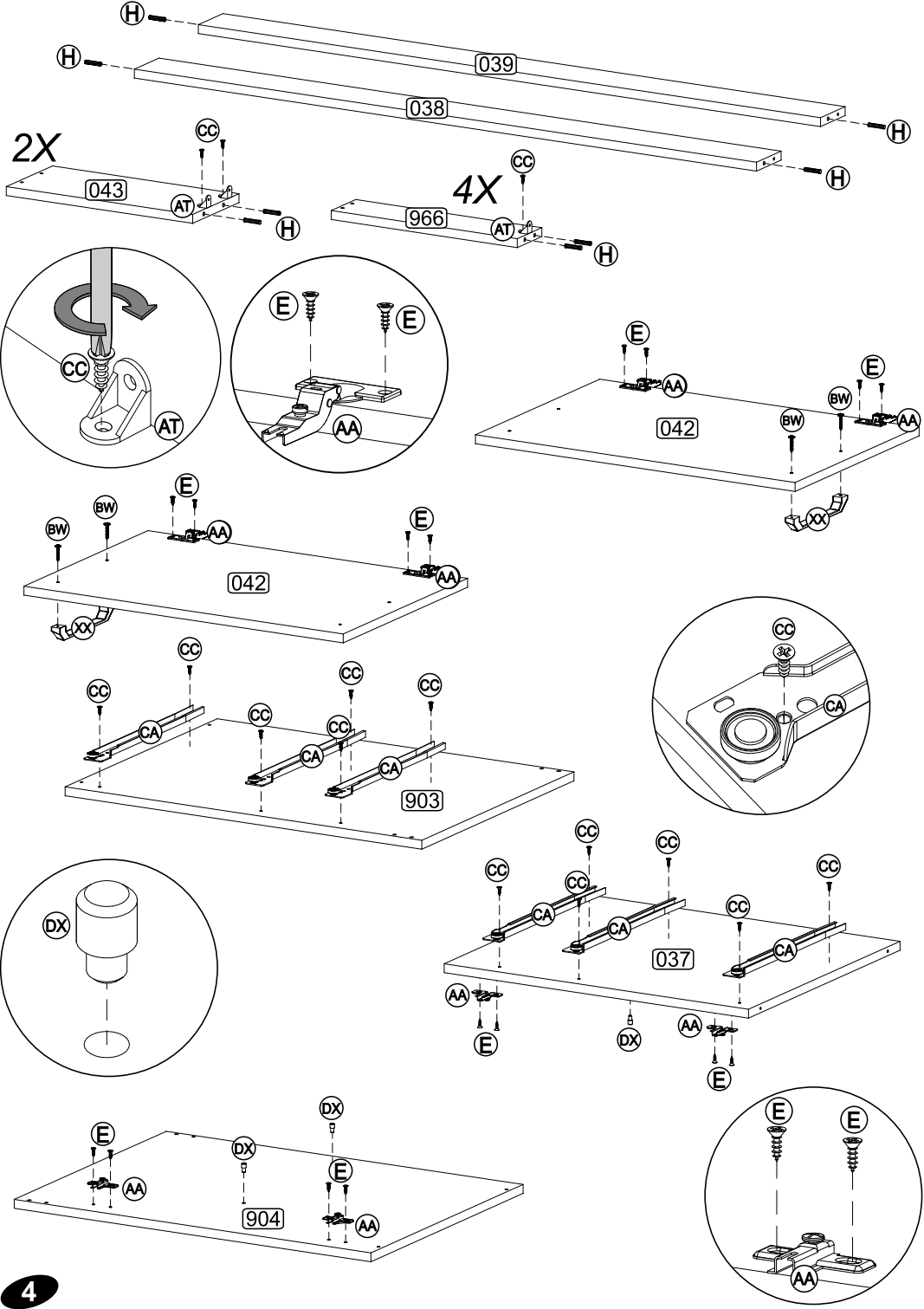

4

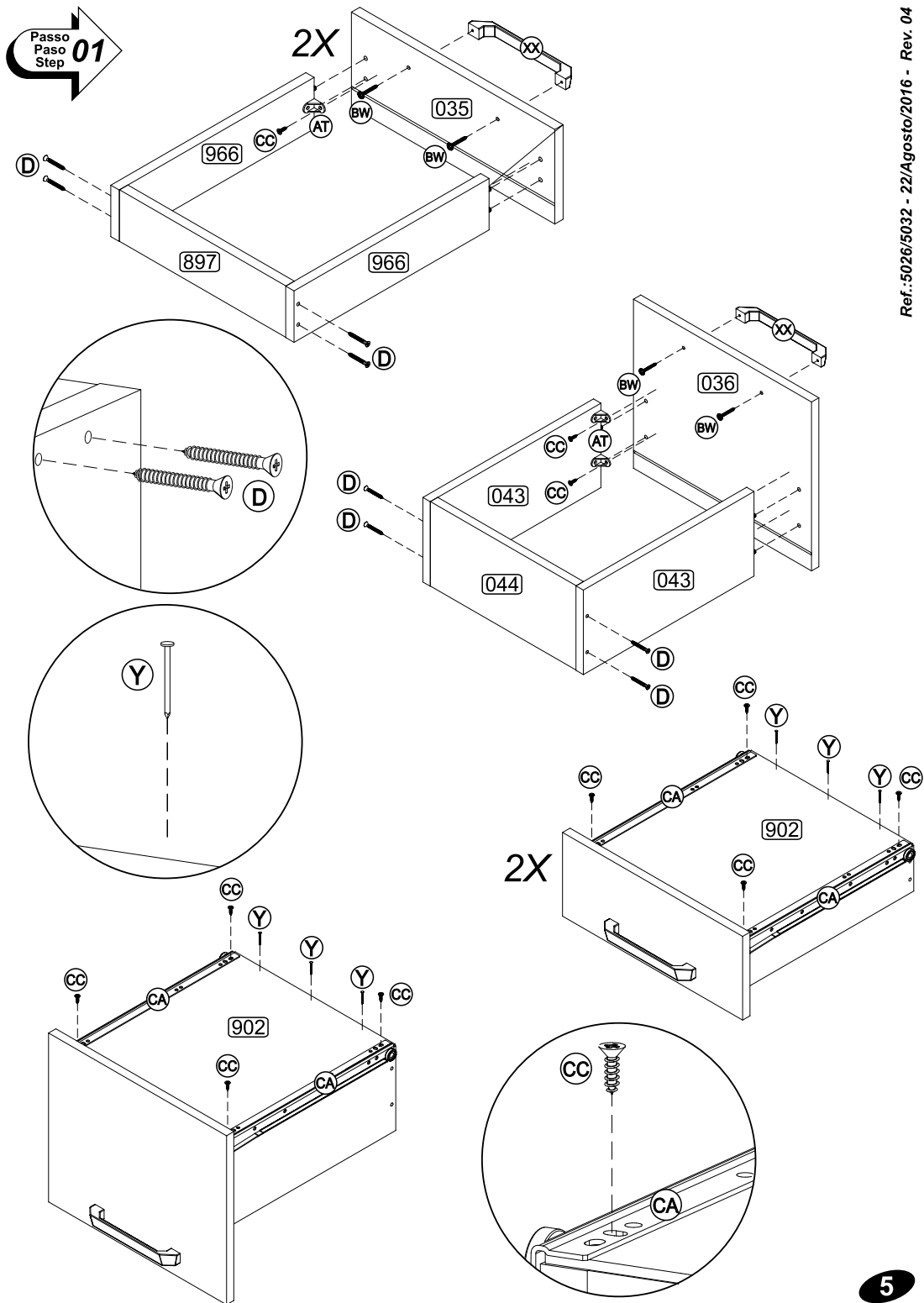

**Passo
Paso
Step**
01

5

Fixação na Parede
Montaje en la Pared
Wall Assembly

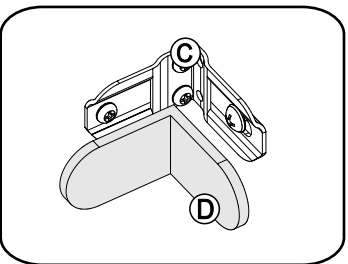
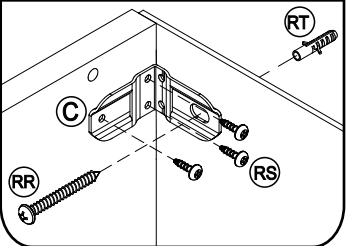

União dos Módulos
Unión de los módulos
Pieces Junction

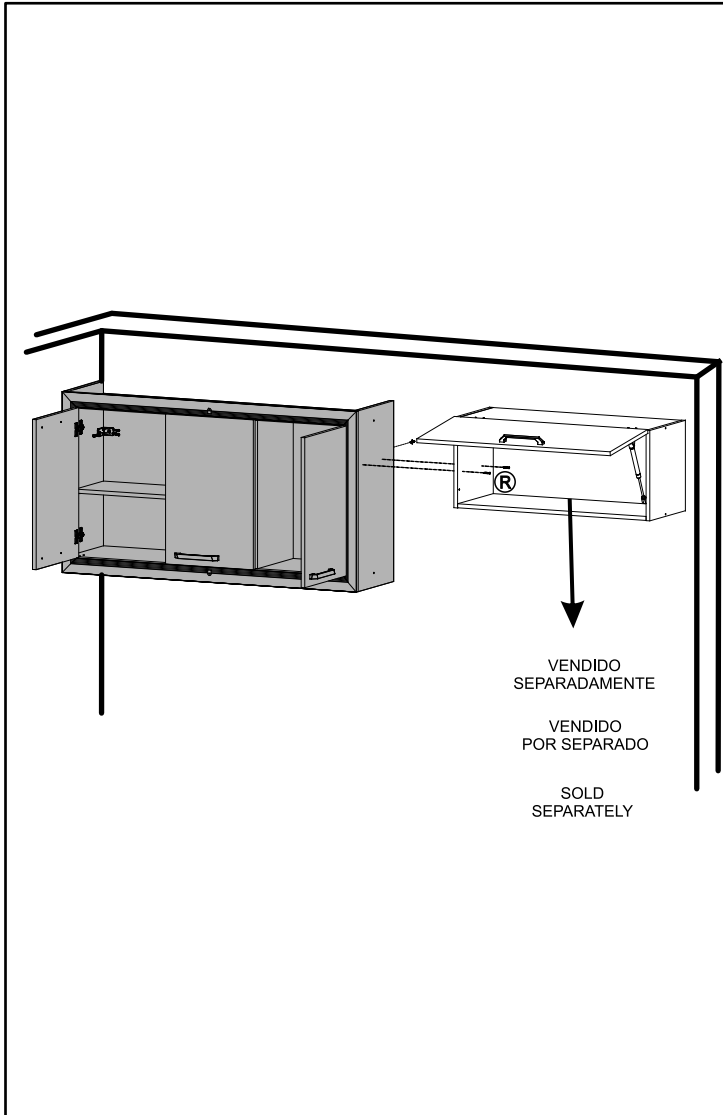
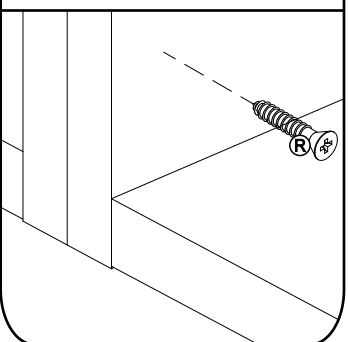

INSTRUÇÕES DE MONTAGEM
INSTRUCCIONES DE ARMADO
ASSEMBLY INSTRUCTIONS

REF.5028

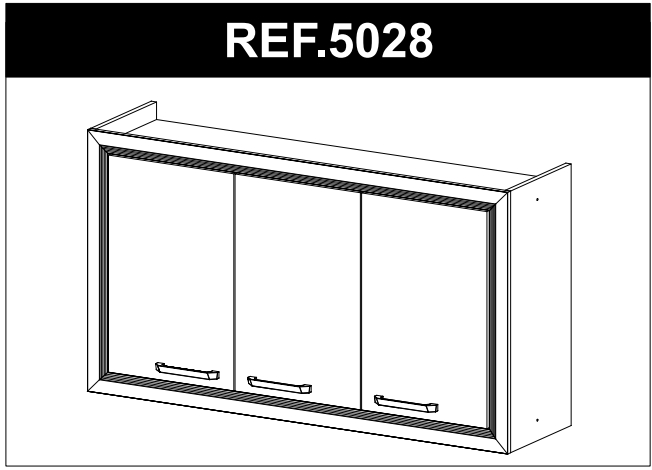

**REF.: 5028/5043/
5047**

REF.5043

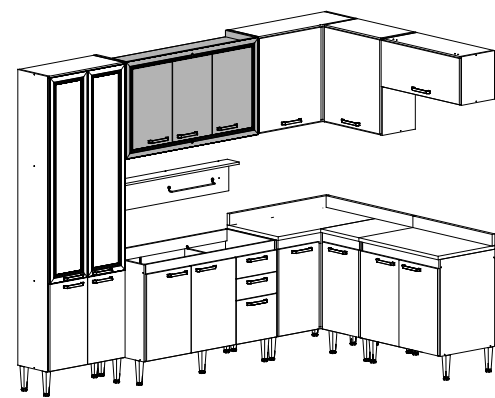

REF.5047

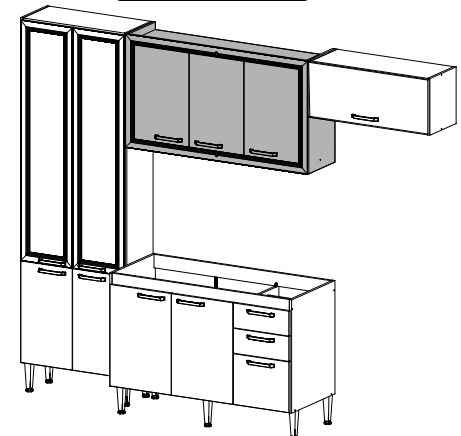





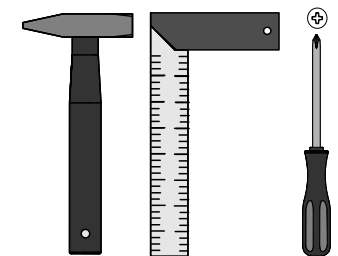
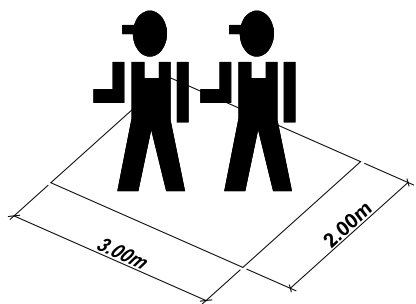



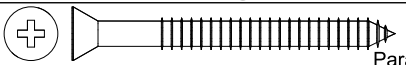
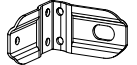
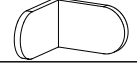
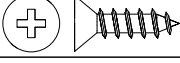

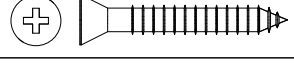
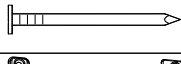

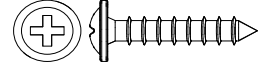
MULTIMÓVEIS
decor

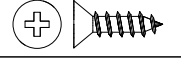
Rua Carlos Dreher Neto, 1918, Fone: (54) 2102 4000, FAX: (54) 2102 4050
 CEP 95700-000 - BENTO GONÇALVES - RS - BRASIL
 CNPJ: 00.349.443/0001-92
 e-mail: multimoveis@multimoveis.com / site: www.multimoveis.com

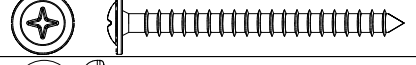

LISTA DE FERRAGENS / LISTA DE MATERIALES / HARDWARE LIST

A		Tampa Adesiva	09
B		Parafuso 4,5 x 50	06
C		Suporte Aéreo	04
D		Capa p/ Suporte Aéreo	04
E		Parafuso 3,5 x 14	24
H		Cavilha 6,0 x 30	20
R		Parafuso 4,0 x 25	04
Y		Prego 10 x 10	40
AA		Dobradiça	06
AT		Cantoneira Plástica	08
BW		Parafuso 3,5 x 25	06
BX		Bisnaga de Cola 5g	01
CC		3,5 X 12	16
DX		Suporte de Prateleira 5mm	04
RR		5,0 x 45	04
RS		3,5 x 14	12
RT		Bucha Ø8mm	04
XX		Puxador 160mm	03

Passo
Paso
Step **05**

COBRIR OS PARAFUSOS
TAMPA ADESIVA
TAPA ADESIVA
STICKER
 TAPA LOS TORNILLOS / COVER THE SCREWS

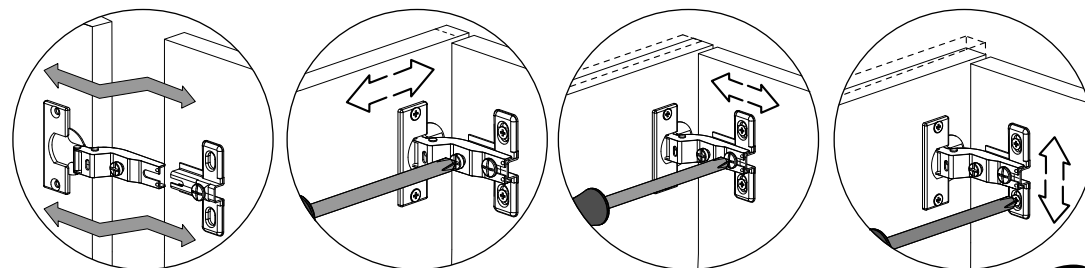
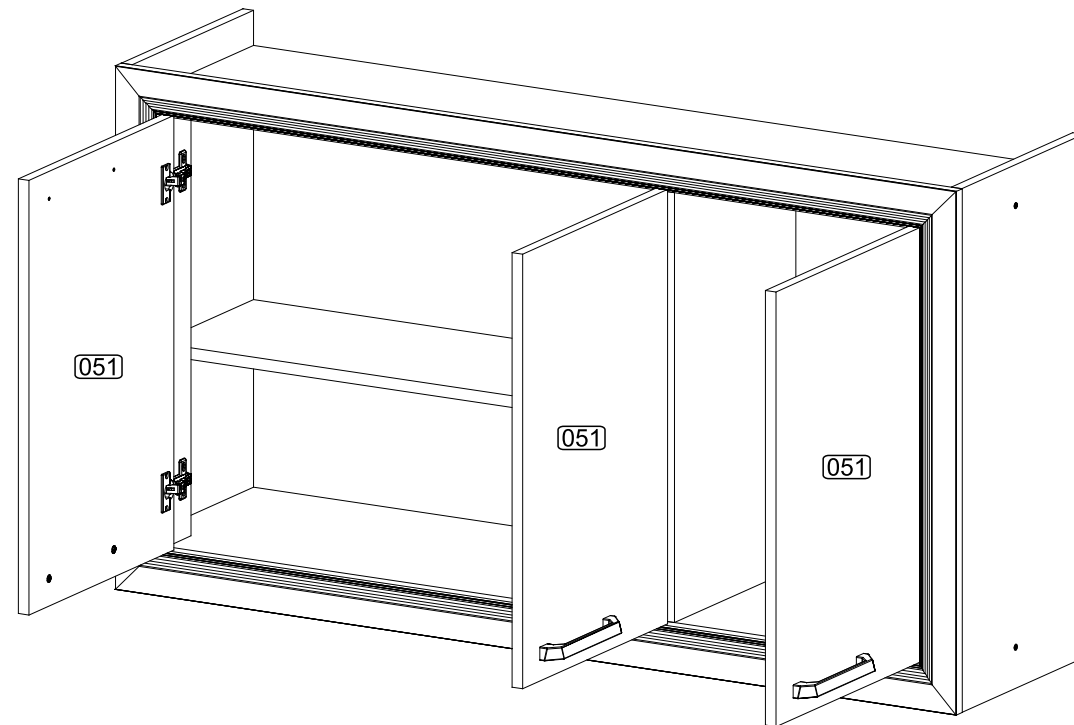



Utilizar a régua abaixo para medir as ferragens:

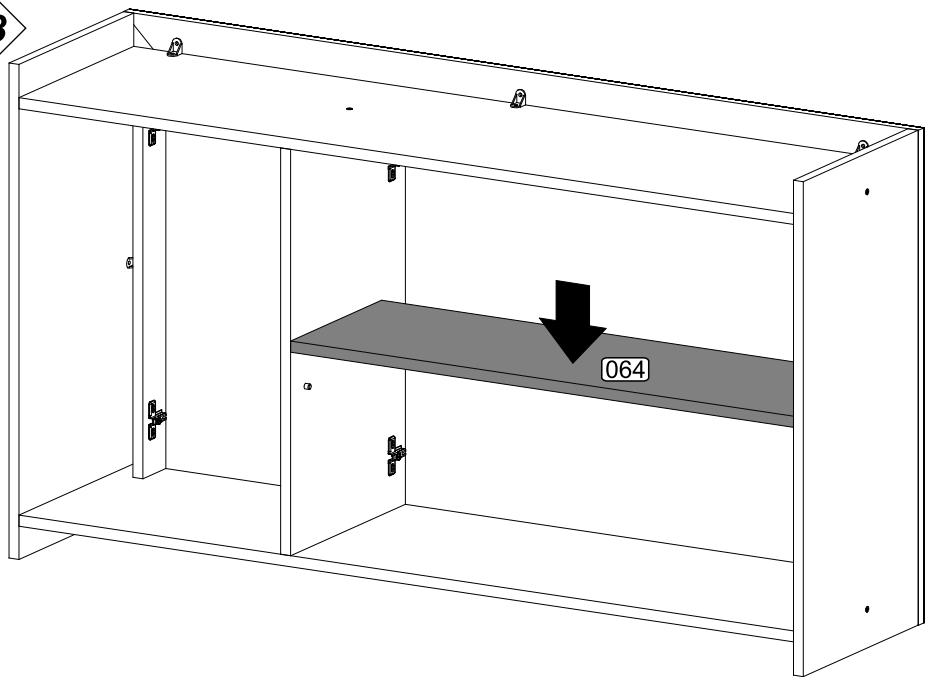

Passo
Paso
Step **03**







Senhor montador!
 Informamos que a numeração das peças encontra-se no topo das mesmas conforme desenho acima.

Señor Armador!
 Les informamos que la numeración de las piezas encuentranse arriba de las mismas, de acuerdo al modelo arriba.

Dear Assembler!
 We inform you that the number of each piece is located on the top of it, according to the model shown above.

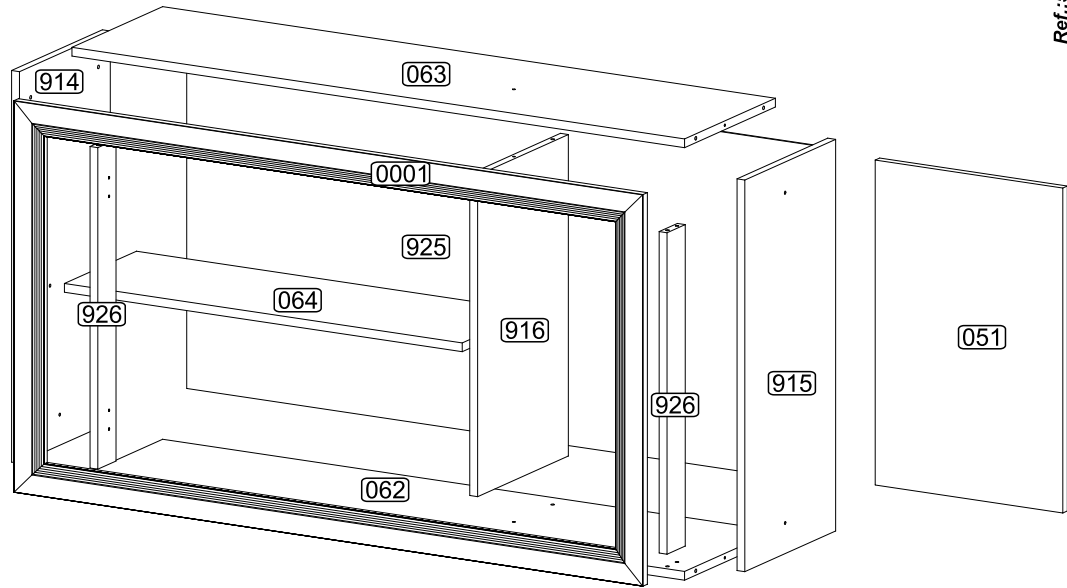
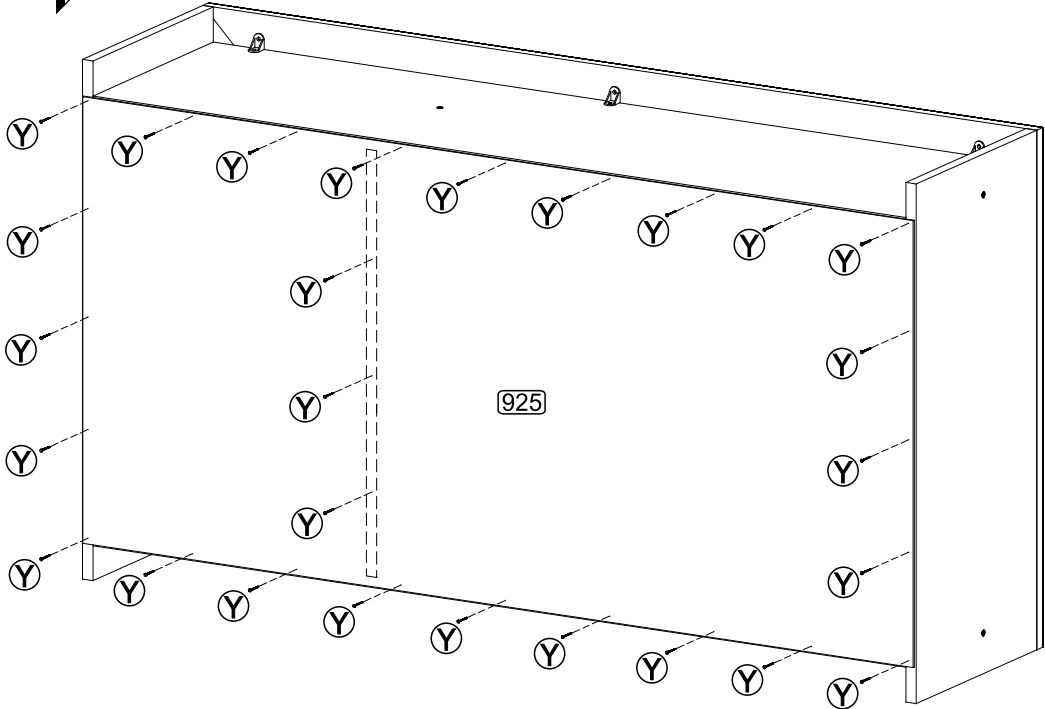
Passo
Paso
Step **04**



POR LISTA DE PEÇAS

Nº	DENOMINAÇÃO
051	PORTA
062	BASE
063	TAMPO
064	PRATELEIRA
914	LATERAL ESQUERDA
915	LATERAL DIREITA
916	DIVISÃO
925	COSTA
926	PILAstra
0001	MOLDURA

ESP LISTA DE PIEZAS

Nº	DENOMINACIÓN
051	PUERTA
062	BASE
063	TAPA
064	ESTANTE
914	LATERAL IZQUIERDA
915	LATERAL DERECHA
916	DIVISIÓN
925	RESPALDO
926	PILAstra
0001	MOLDURA

ENG PART LIST

Nº	DESCRIPTION
051	DOOR
062	BASE
063	TOP
064	SHELF
914	LEFT SIDE
915	RIGHT SIDE
916	DIVISION
925	BACK
926	DOOR STOP
0001	FRAME

PRÉ-MONTAGEM / PRÉ-ARMADO / PRÉ-ASSEMBLAGE

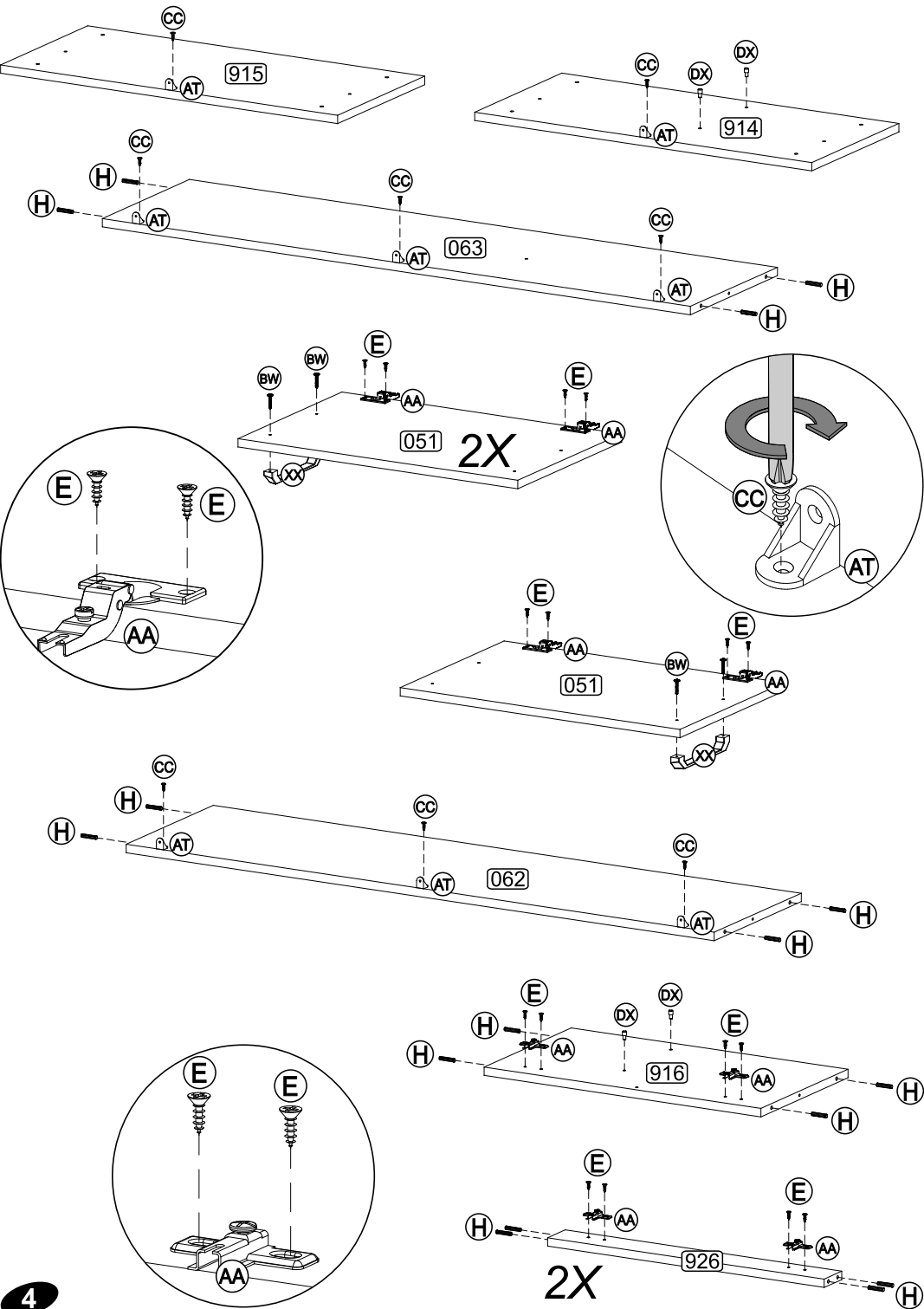

4

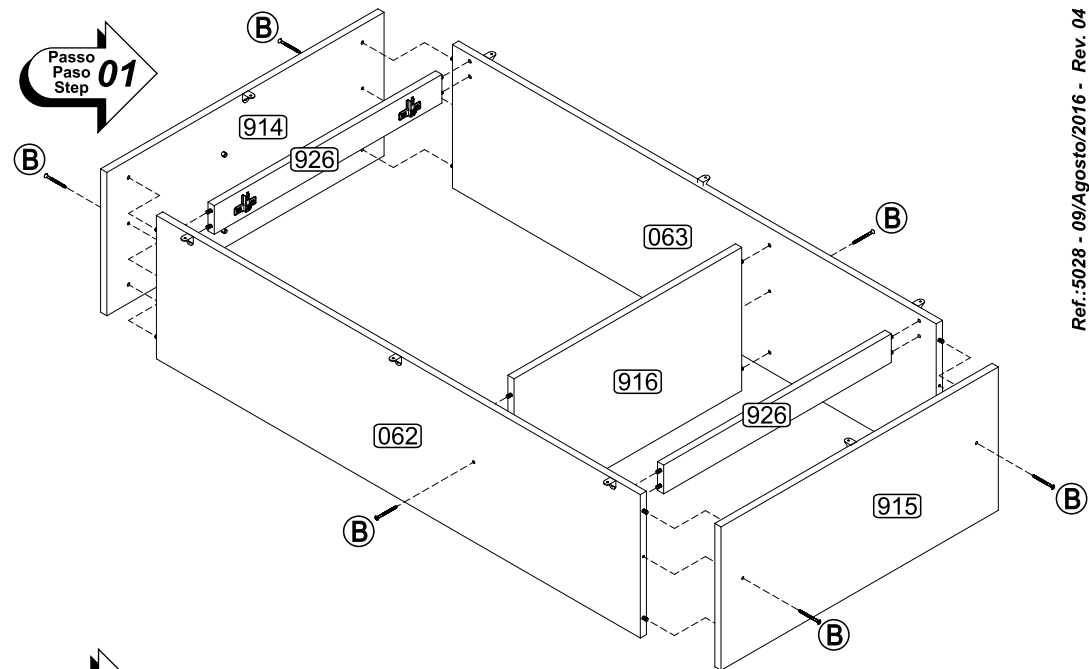

Passo
Paso
Step
02

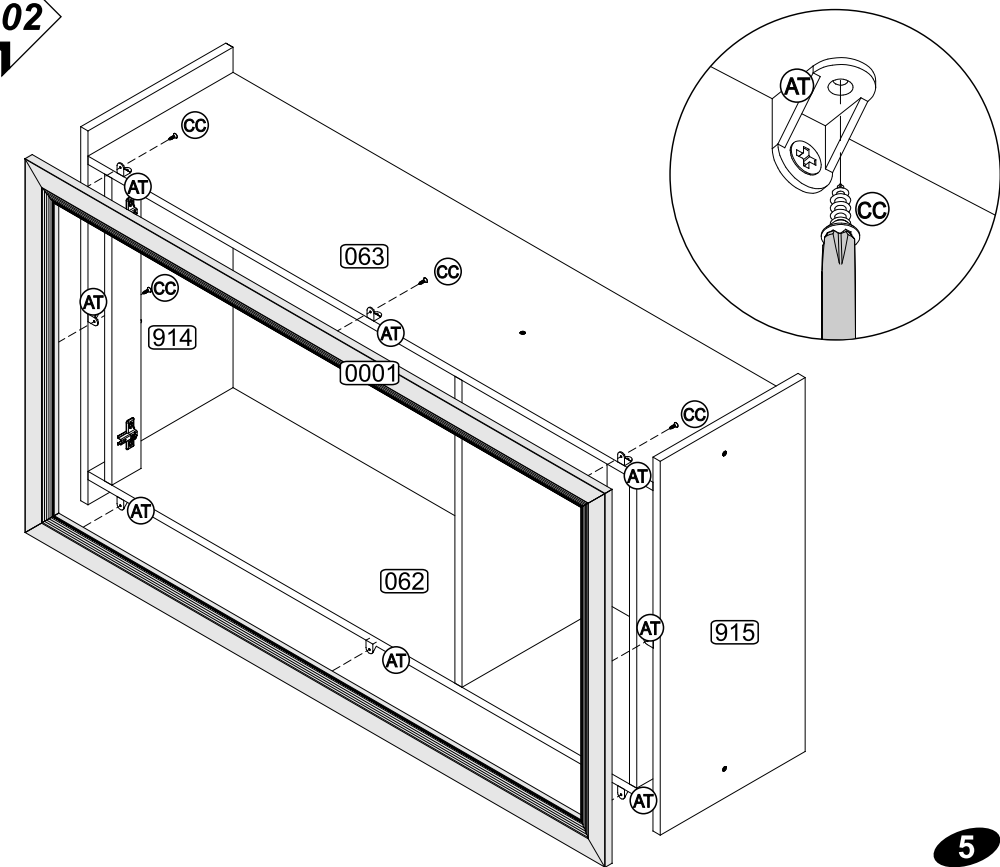

5

INSTRUÇÕES DE MONTAGEM INSTRUCCIONES DE ARMADO ASSEMBLY INSTRUCTIONS

REF.: 5029/5043

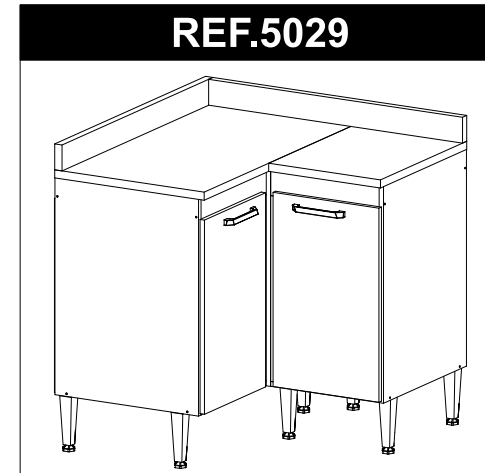
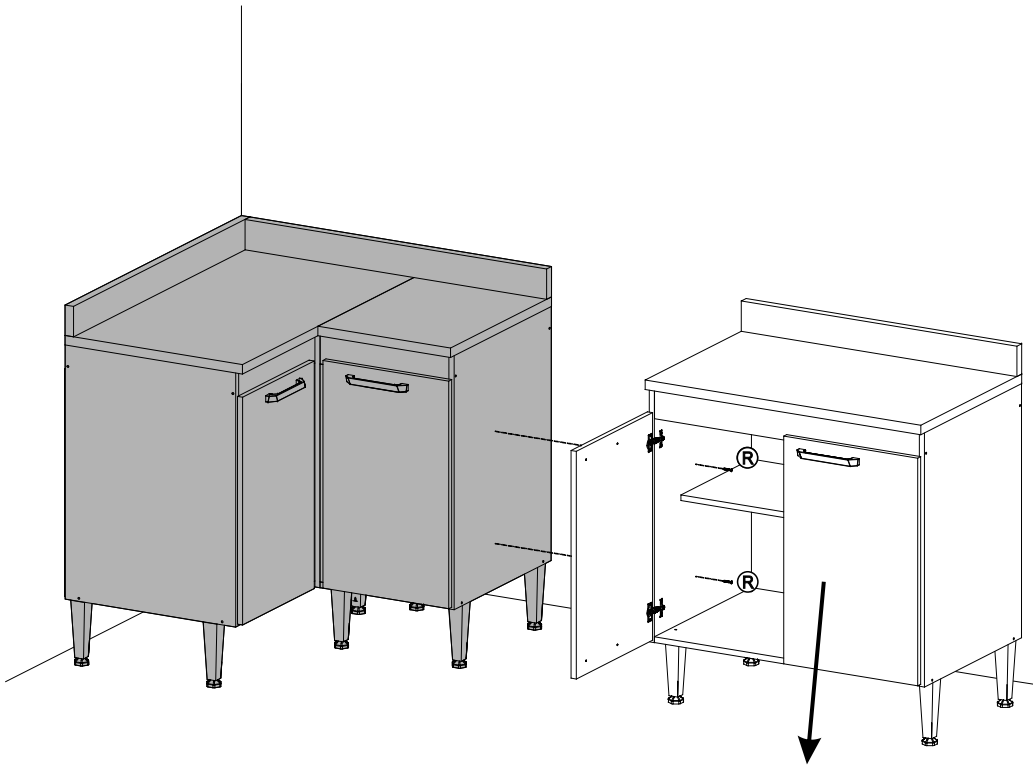

REF.5043

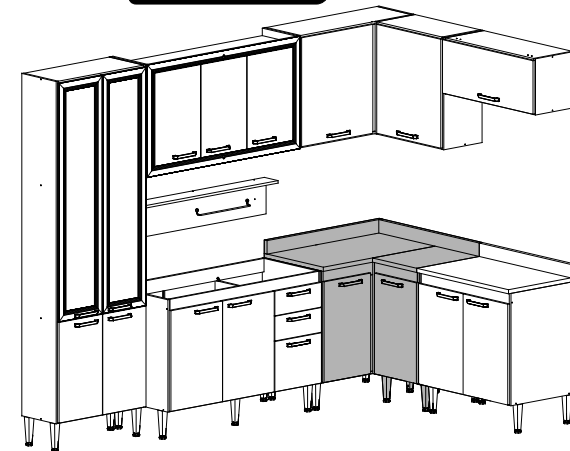

União dos Módulos
Unión de los módulos
Pieces Junction

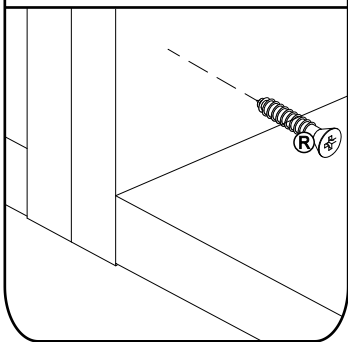







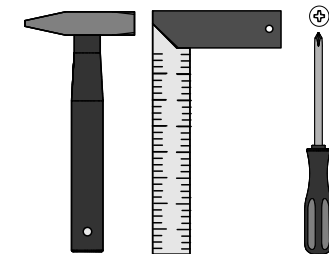
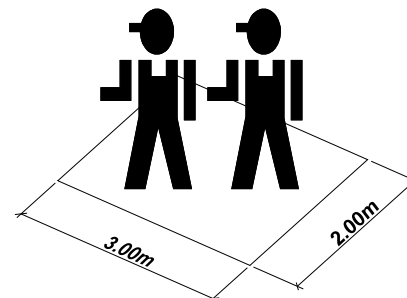

VENDIDO
SEPARADAMENTE
VENDIDO
POR SEPARADO
SOLD
SEPARATELY

MULTIMÓVEIS
decor

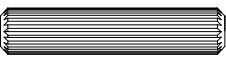
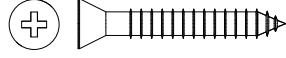
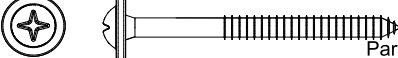
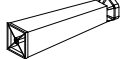
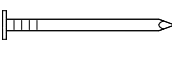
Rua Carlos Dreher Neto, 1918, Fone: (54) 2102 4000, FAX: (54) 2102 4050
CEP 95700-000 - BENTO GONÇALVES - RS - BRASIL
CNPJ: 00.349.443/0001-92
e-mail: multimoveis@multimoveis.com / site: www.multimoveis.com

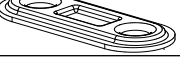
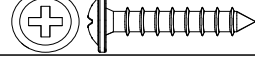

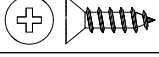
LISTA DE FERRAGENS / LISTA DE MATERIALES / HARDWARE LIST

A		Tampa Adesiva	15
B		Parafuso 4,5 x 50	23
E		Parafuso 3,5 x 14	18
H		Cavilha 6,0 x 30	09
R		Parafuso 4,0 x 25	12
S		Parafuso 5,0 X 45	08
X		Pé com Regulagem	08
Y		Prego 10 x 10	30
AA		Dobradiça	04
AT		Cantoneira Plástica	09
BQ		Cantoneira de Fixação	01
BW		Parafuso 3,5 x 25	04
BX		Bisnaga de Cola 5g	01
CC		3,5 X 12	22
DX		Suporte de Prateleira 5mm	08
XX		Puxador 160mm	02

Passo
Paso
Step
05

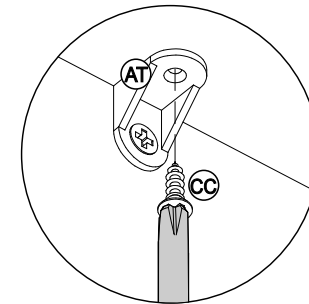
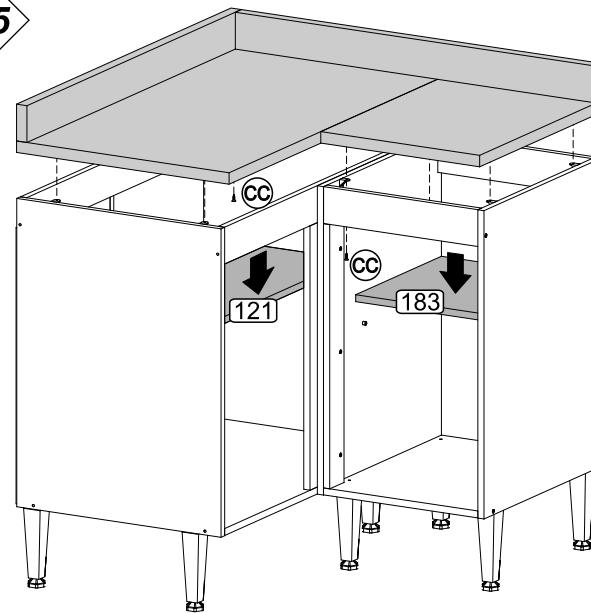

Passo
Paso
Step
06

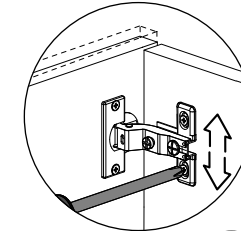
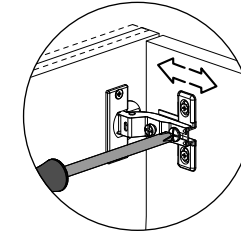
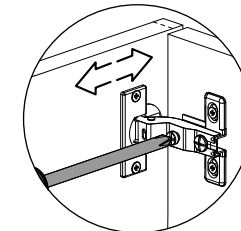
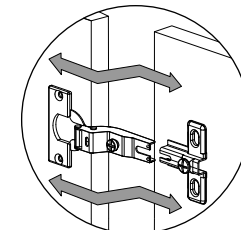
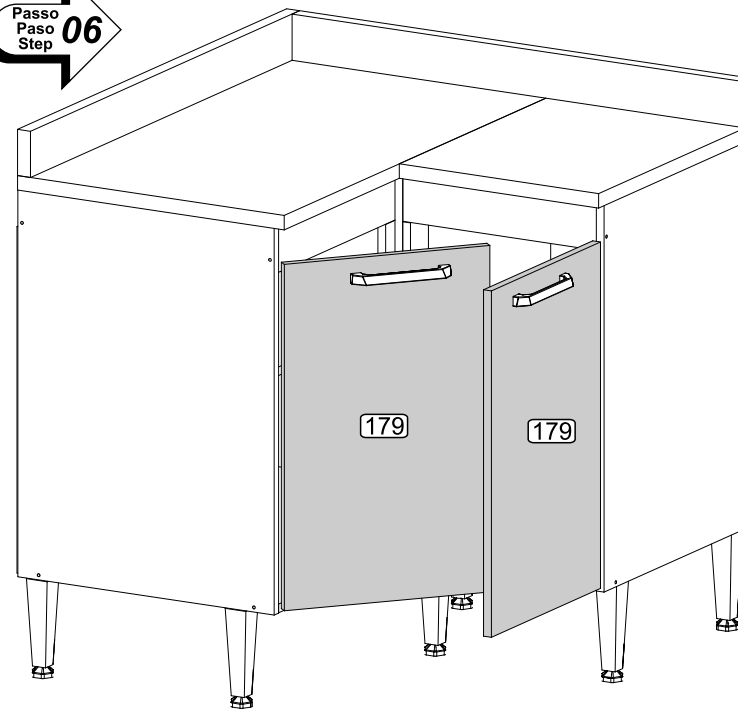

Utilizar a régua abaixo para medir as ferragens:



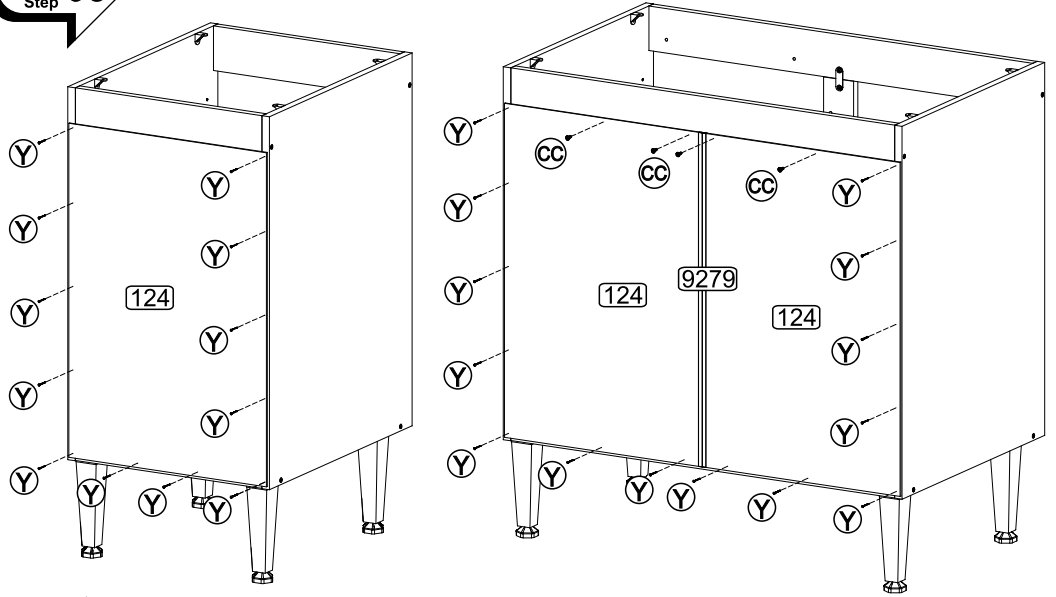

Passo
Paso
Step **03**

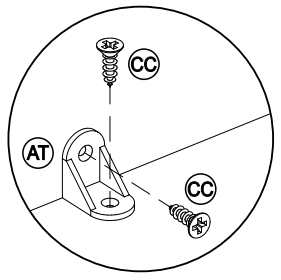
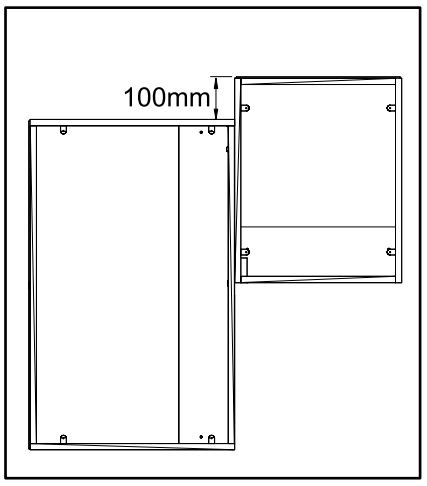
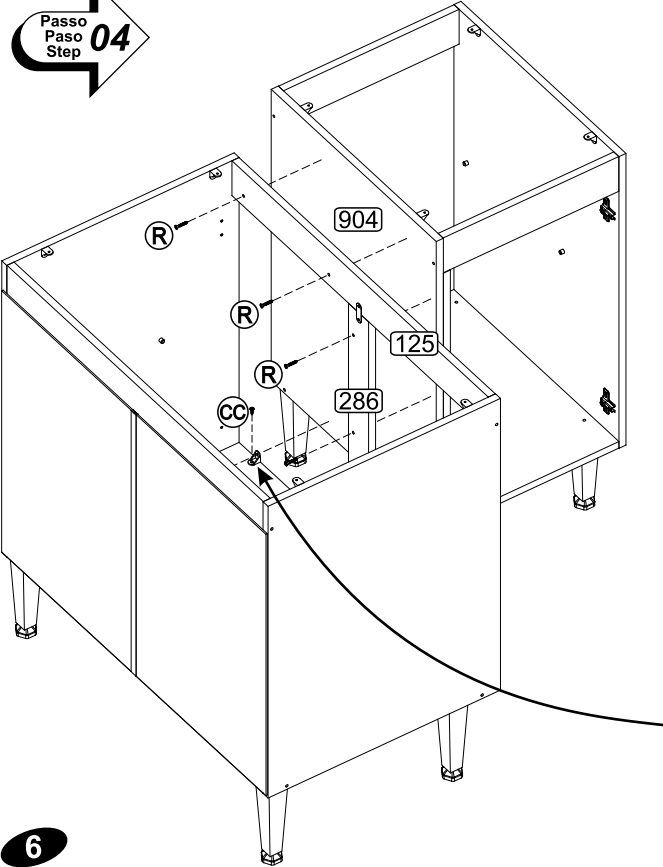

Passo
Paso
Step **04**



Senhor montador!
Informamos que a numeração das peças encontra-se no topo das mesmas conforme desenho acima.

Señor Armador!
Les informamos que la numeración de las piezas encuentranse arriba de las mismas, de acuerdo al modelo arriba.

Dear Assembler!
We inform you that the number of each piece is located on the top of it, according to the model shown above.

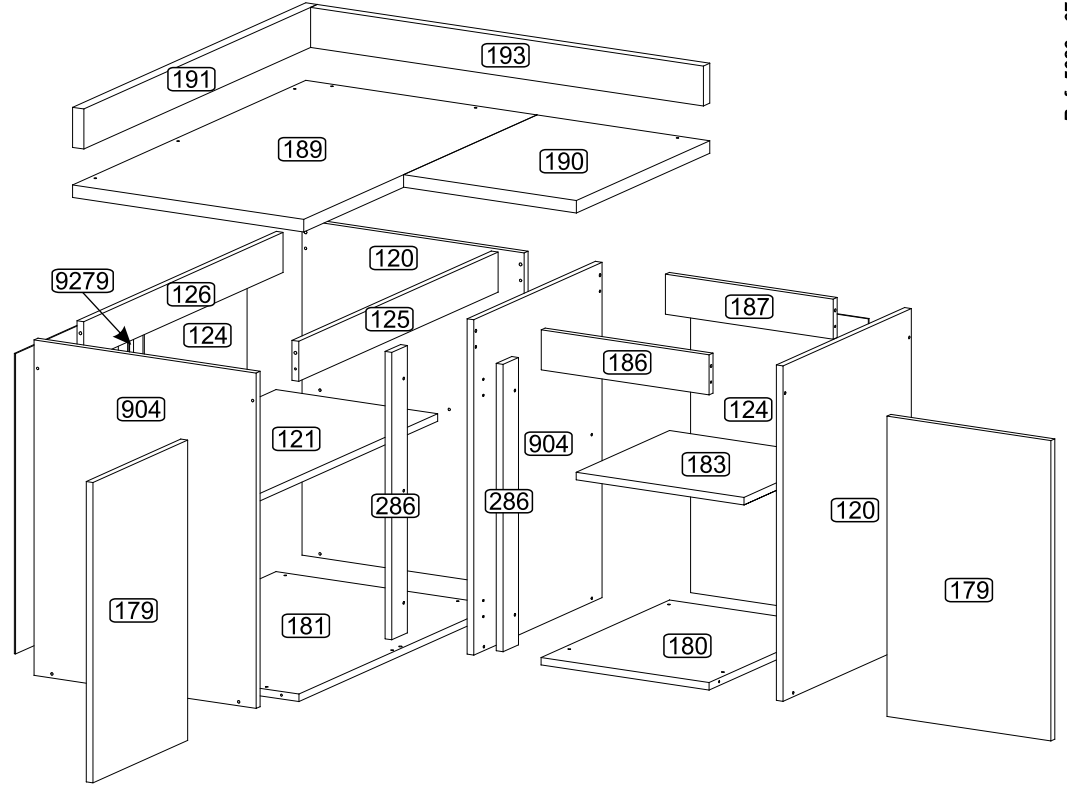

POR

LISTA DE PEÇAS

Nº	DENOMINAÇÃO
120	LATERAL DIREITA
121	PRATELEIRA MOVEL
124	COSTA
125	TRAVESSA
126	TRAVESSA TRASEIRA
179	PORTA
180	BASE MENOR
181	BASE MAIOR
183	PRATELEIRA MOVEL MENOR
186	TRAVESSA MENOR
187	TRAVESSA TRASEIRA MENOR
189	TAMPO MAIOR
190	TAMPO MENOR
191	MOLDURA MAIOR
193	MOLDURA
286	PILASTRA
904	LATERAL ESQUERDA
9279	PERFIL I

ESP

LISTA DE PIEZAS

Nº	DENOMINACIÓN
120	LATERAL DERECHA
121	ESTANTE MOVIL
124	RESPALDO
125	TRAVIESA
126	TRAVIESA TRASERA
179	PUERTA
180	BASE MENOR
181	BASE MAYOR
183	ESTANTE MÓVIL MENOR
186	TRAVIESA MENOR
187	TRAVIESA TRASERA MENOR
189	TAPA MAYOR
190	TAPA MENOR
191	MOLDURA MAYOR
193	MOLDURA
286	PILASTRA
904	LATERAL IZQUIERDA
9279	PERFIL I

ENG

PART LIST

Nº	DESCRIPTION
120	RIGHT SIDE
121	MOVABLE SHELF
124	BACK
125	CROSS BAR
126	BACK BEAM
179	DOOR
180	SMALL BASE
181	LARGE BASE
183	SMALLER MOVABLE SHELF
186	SMALL CROSS BAR
187	SMALL BACK BEAM
189	LARGER TOP
190	SMALLER TOP
191	LARGER FRAME
193	FRAME
286	DOOR STOP
904	LEFT SIDE
9279	I PROFILE

PRÉ-MONTAGEM / PRÉ-ARMADO / PRÉ-ASSEMBLAGE

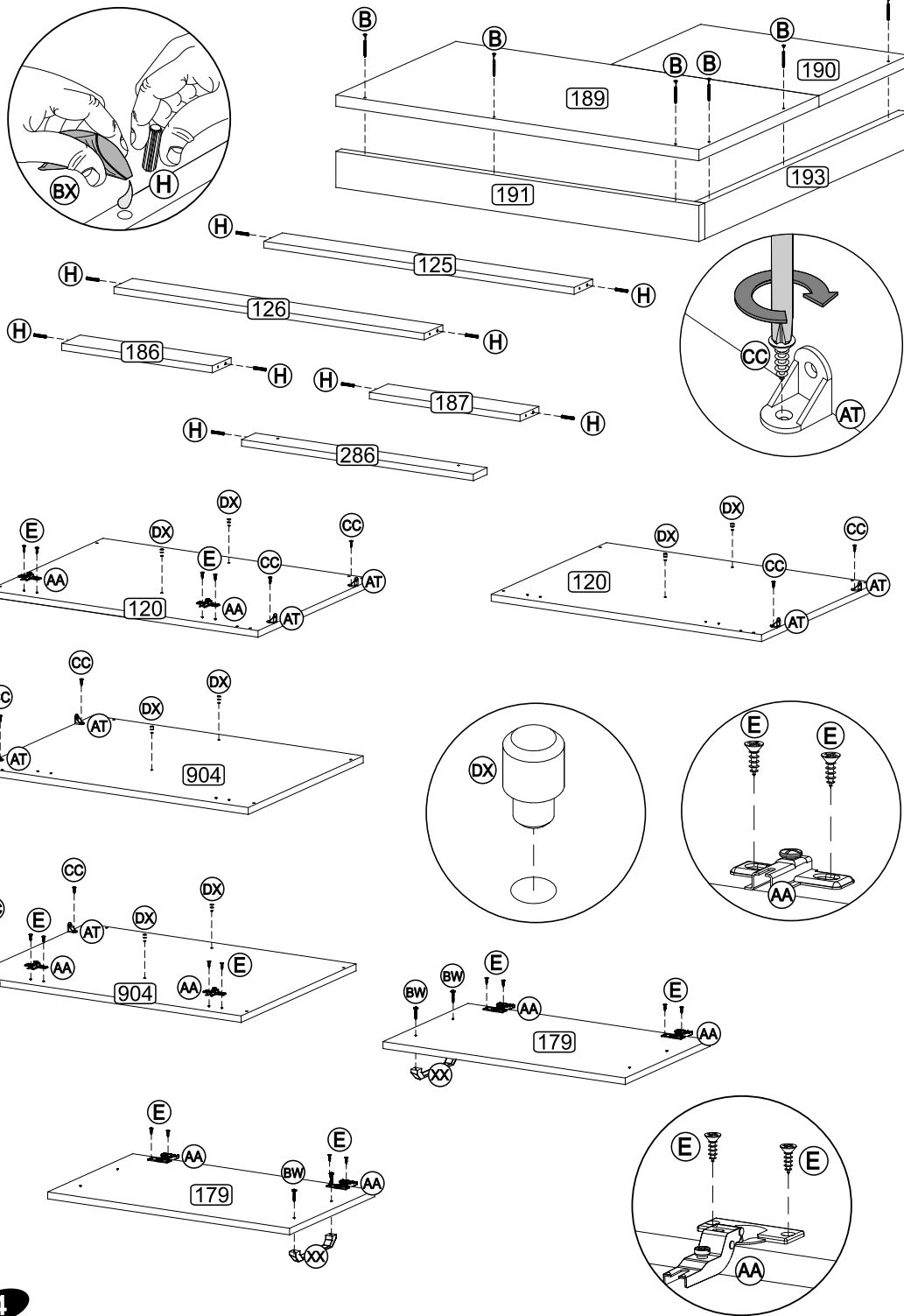

Passo
Paso
Step

01

COBRIR OS PARAFUSOS
TAMPA ADESIVA
TAPA ADESIVA
STICKER
 TAPA LOS TORNILLOS / COVER THE SCREWS

Passo
Paso
Step

02

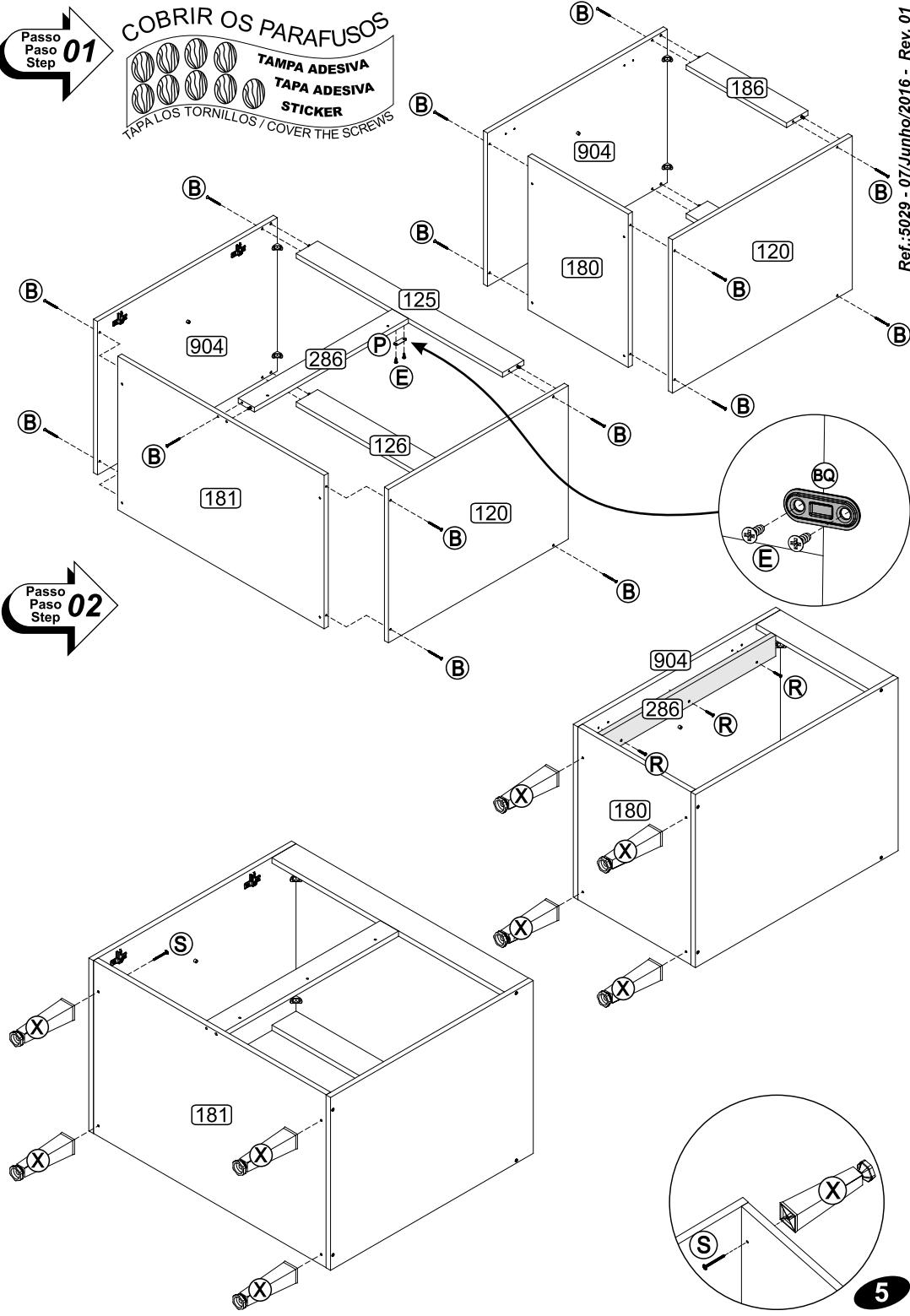

INSTRUÇÕES DE MONTAGEM
INSTRUCCIONES DE ARMADO
ASSEMBLY INSTRUCTIONS

REF.: 5030/5043

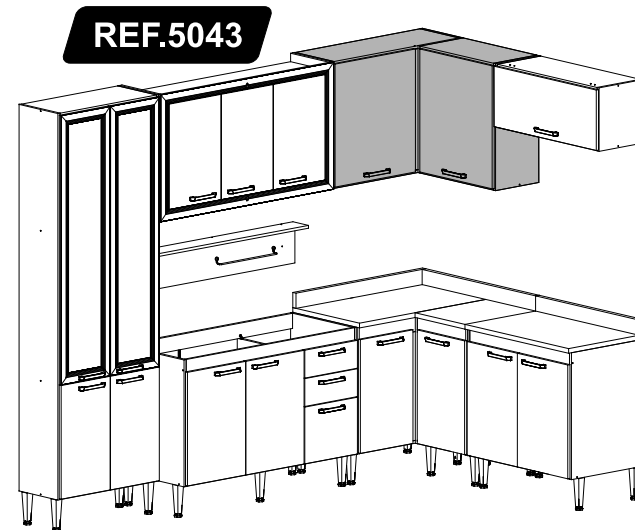
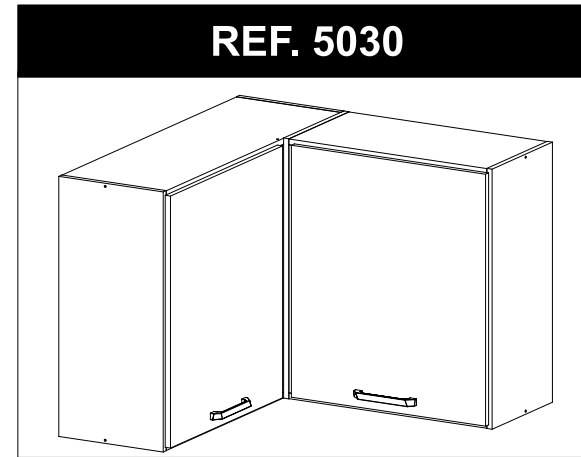
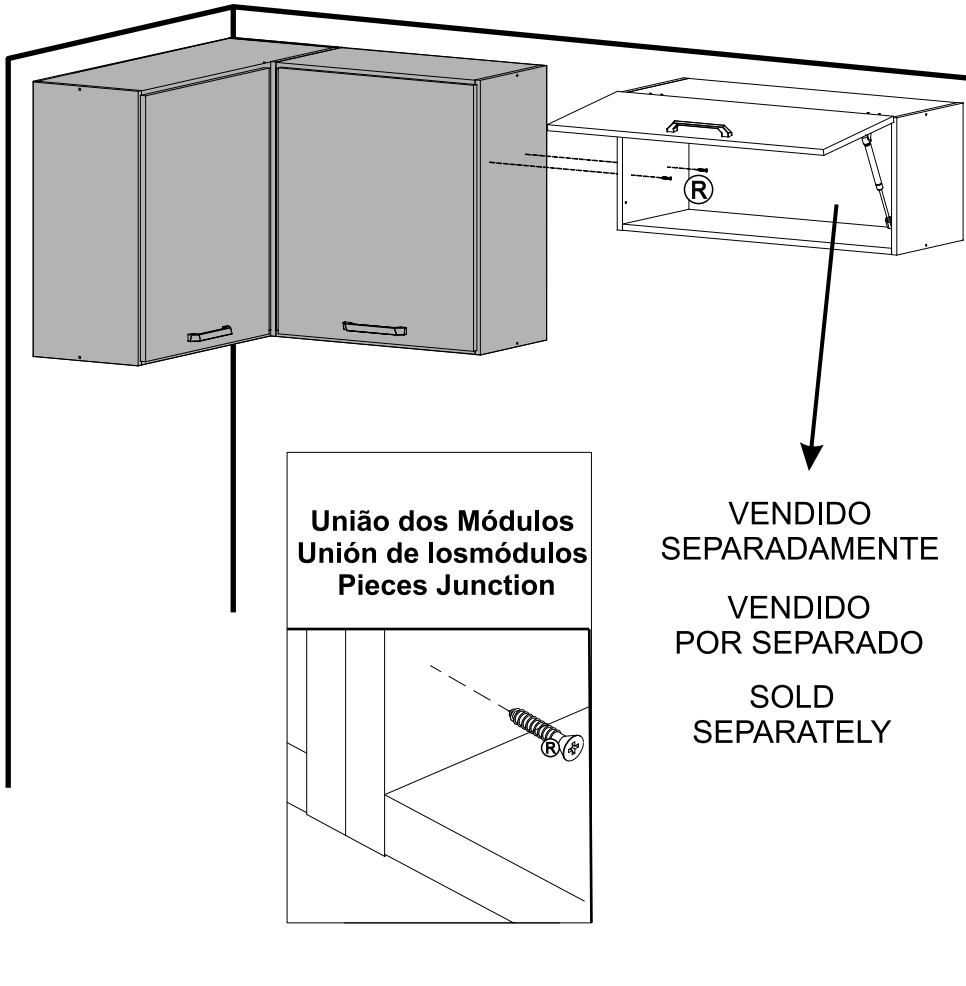





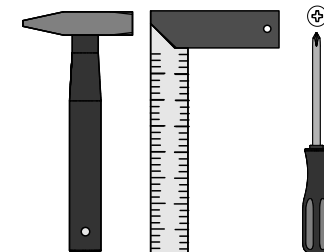
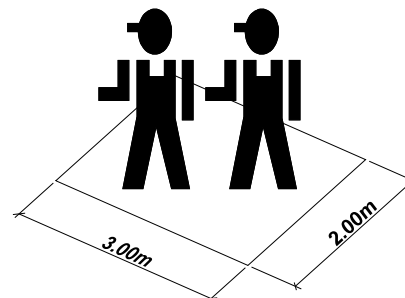





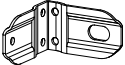

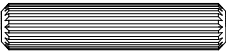

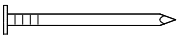

MULTIMÓVEIS
decor

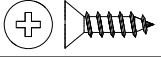
Rua Carlos Dreher Neto, 1918, Fone: (54) 2102 4000, FAX: (54) 2102 4050
 CEP 95700-000 - BENTO GONÇALVES - RS - BRASIL
 CNPJ: 00.349.443/0001-92
 e-mail: multimoveis@multimoveis.com / site: www.multimoveis.com



LISTA DE FERRAGENS / LISTA DE MATERIALES / HARDWARE LIST

A		Tampa Adesiva	14
B		Parafuso 4,5 x 50	10
C		Suporte Aéreo	04
D		Capa p/ Suporte Aéreo	04
E		Parafuso 3,5 x 14	16
H		Cavilha 6,0 x 30	18
R		Parafuso 4,0 x 25	10
Y		Prego 10 x 10	50
AA		Dobradiça	04
AT		Cantoneira Plástica	02
BW		Parafuso 3,5 x 25	04
BX		Bisnaga de Cola 5g	01
CC		3,5 X 12	04
DX		Suporte de Prateleira 5mm	08
RR		5,0 x 45	04
RS		3,5 x 14	12
RT		Bucha Ø8mm	04
XX		Puxador 160mm	02

Passo
Paso
Step **05**

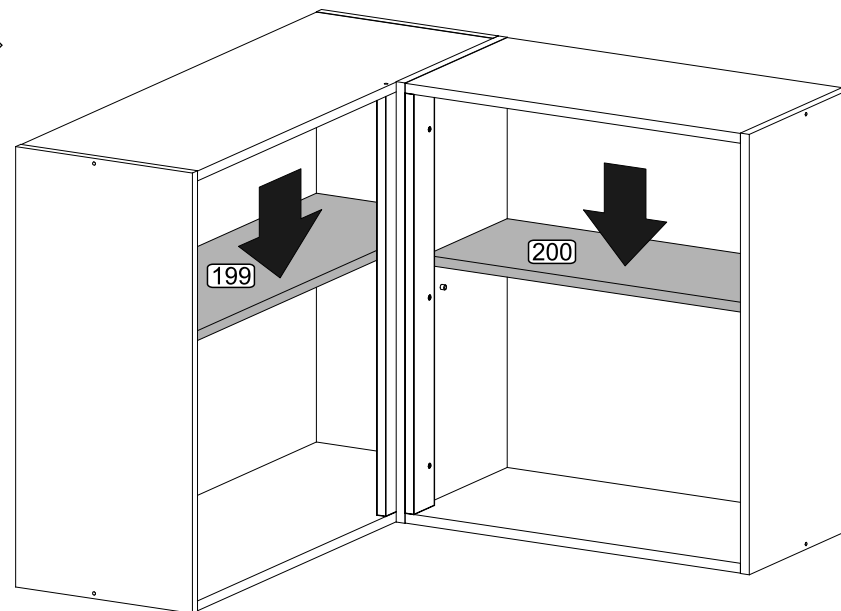

Passo
Paso
Step **06**

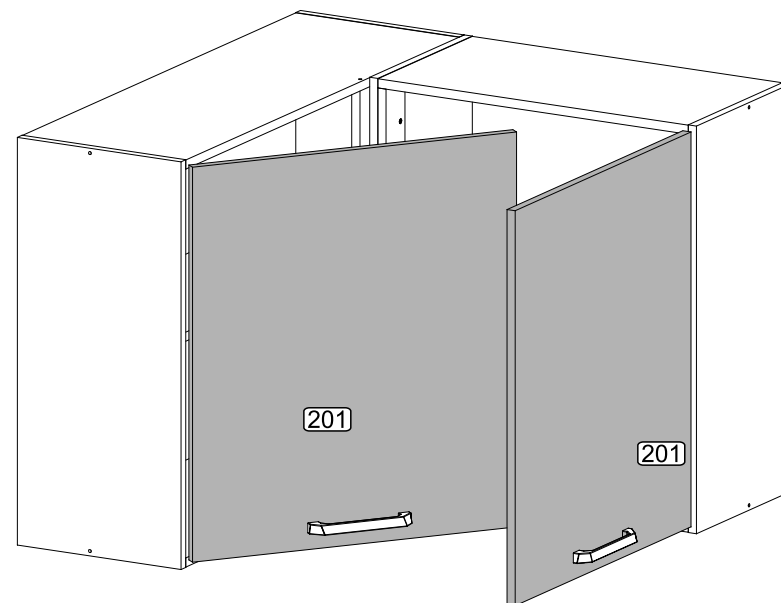

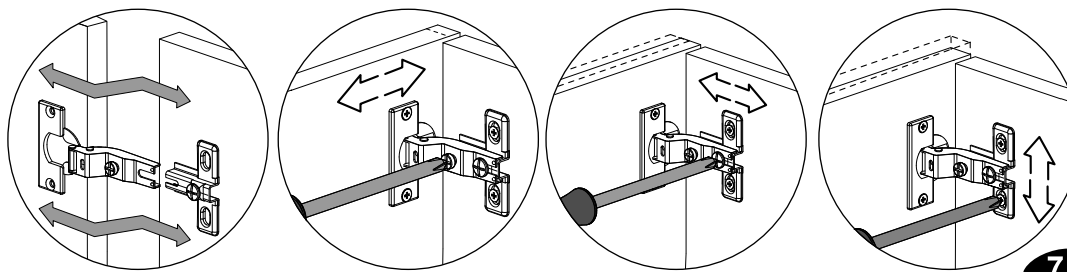
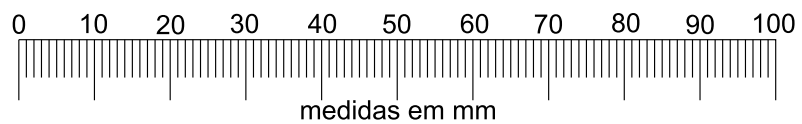

Utilizar a régua abaixo para medir as ferragens:

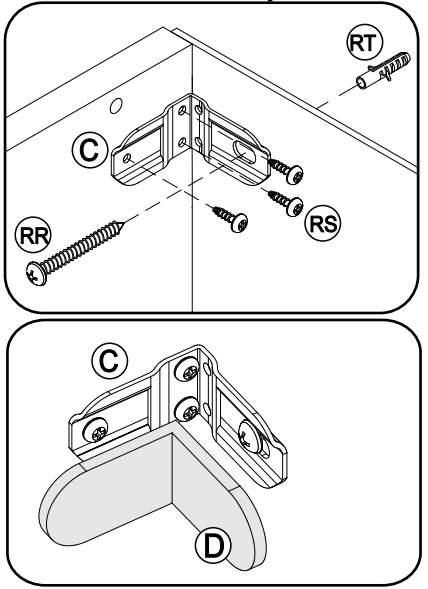

Passo
Paso
Step **03**

Fixação na Parede/Montaje en la Pared
Wall Assembly





 Senhor montador!
 Informamos que a numeração das peças encontra-se no topo das mesmas conforme desenho acima.

Señor Armador!
 Les informamos que la numeración de las piezas encuentranse arriba de las mismas, de acuerdo al modelo arriba.

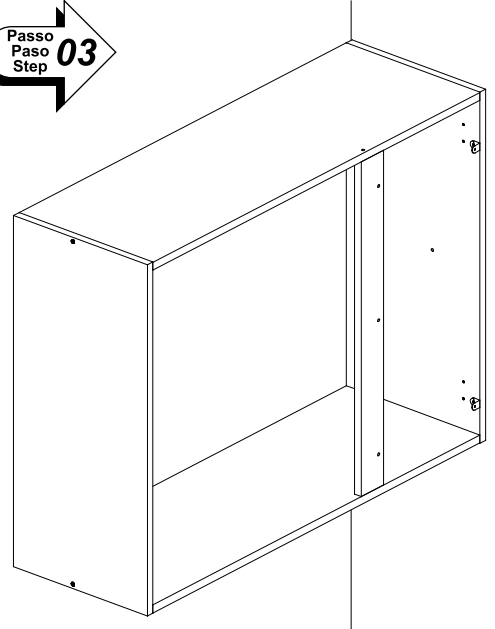
Dear Assembler!
 We inform you that the number of each piece is located on the top of it, according to the model shown above.



Passo
Paso
Step **04**

COBRIR OS PARAFUSOS
TAMPA ADESIVA
TAPA ADESIVA
STICKER
 TAPA LOS TORNILLOS / COVER THE SCREWS

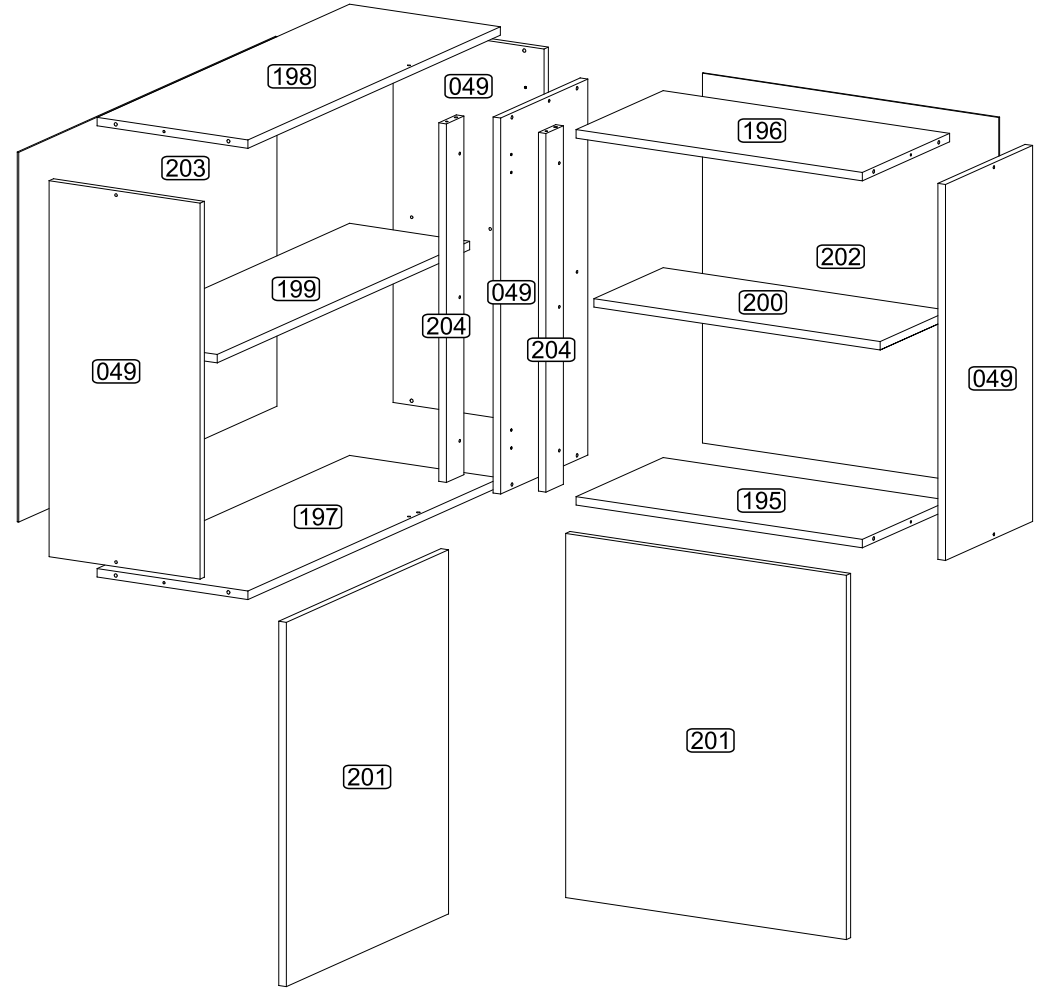
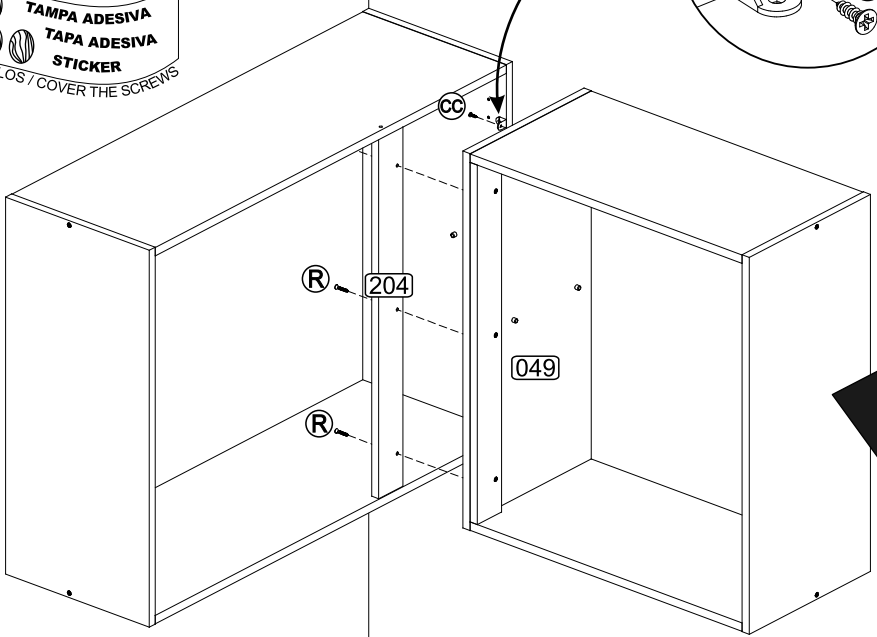
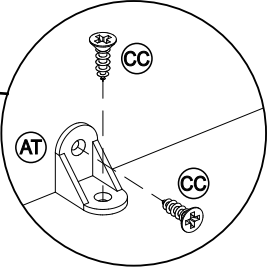

POR	LISTA DE PEÇAS	ESP	LISTA DE PIEZAS	ENG	PART LIST
Nº	DENOMINAÇÃO	Nº	DENOMINACIÓN	Nº	DESCRIPTION
049	- LATERAL	049	- LATERAL	049	- SIDE
195	- BASE MENOR	195	- BASE MENOR	195	- SMALL BASE
196	- TAMPO MENOR	196	- TAPA MENOR	196	- SMALLER TOP
197	- BASE MAIOR	197	- BASE MAYOR	197	- LARGE BASE
198	- TAMPO MAIOR	198	- TAPA MAYOR	198	- LARGER TOP
199	- PRATELEIRA MOVEL MAIOR	199	- ESTANTE MÓVIL MAYOR	199	- LARGER MOVABLE SHELF
200	- PRATELEIRA MOVEL MENOR	200	- ESTANTE MÓVIL MENOR	200	- SMALLER MOVABLE SHELF
201	- PORTA	201	- PUERTA	201	- DOOR
202	- COSTA MENOR	202	- RESPALDO MENOR	202	- SMALLER BACK
203	- COSTA MAIOR	203	- RESPALDO MAYOR	203	- LARGER BACK
204	- PILASTRA	204	- PILASTRA	204	- DOOR STOP

PRÉ-MONTAGEM / PRÉ-ARMADO / PRÉ-ASSEMBLAGE

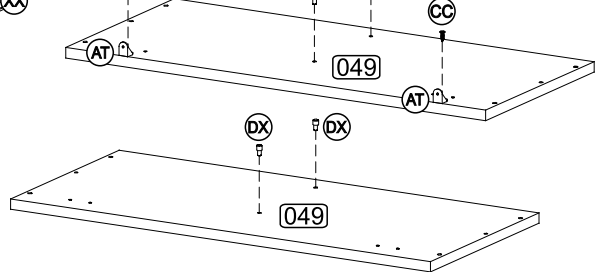
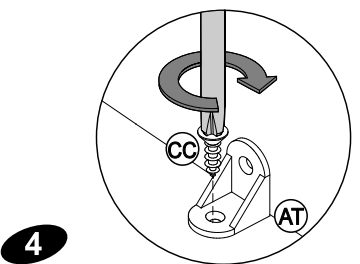
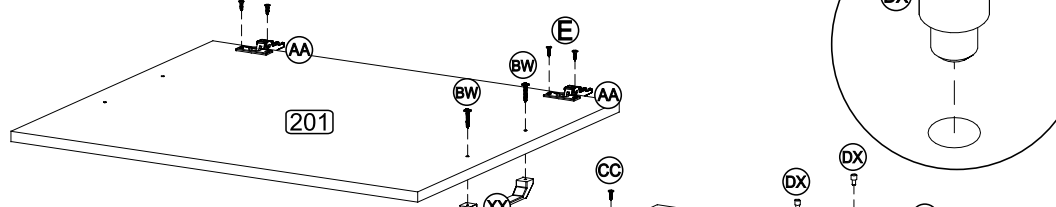
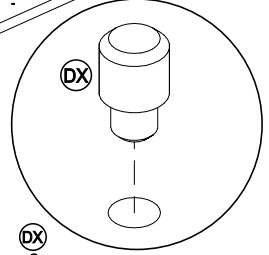
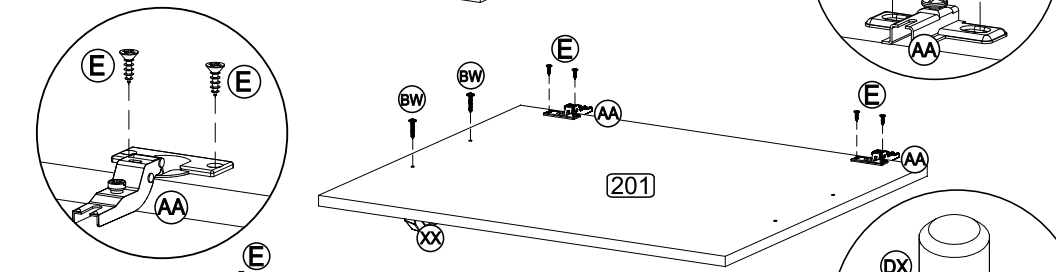
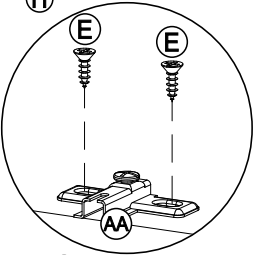
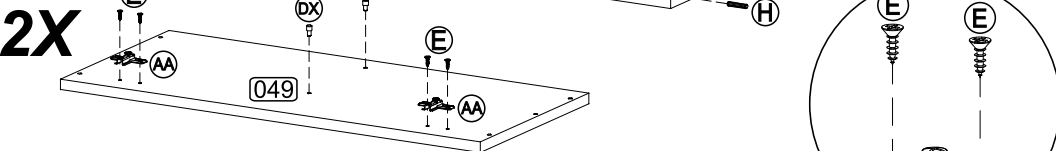
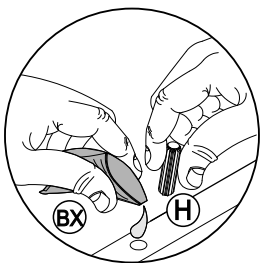
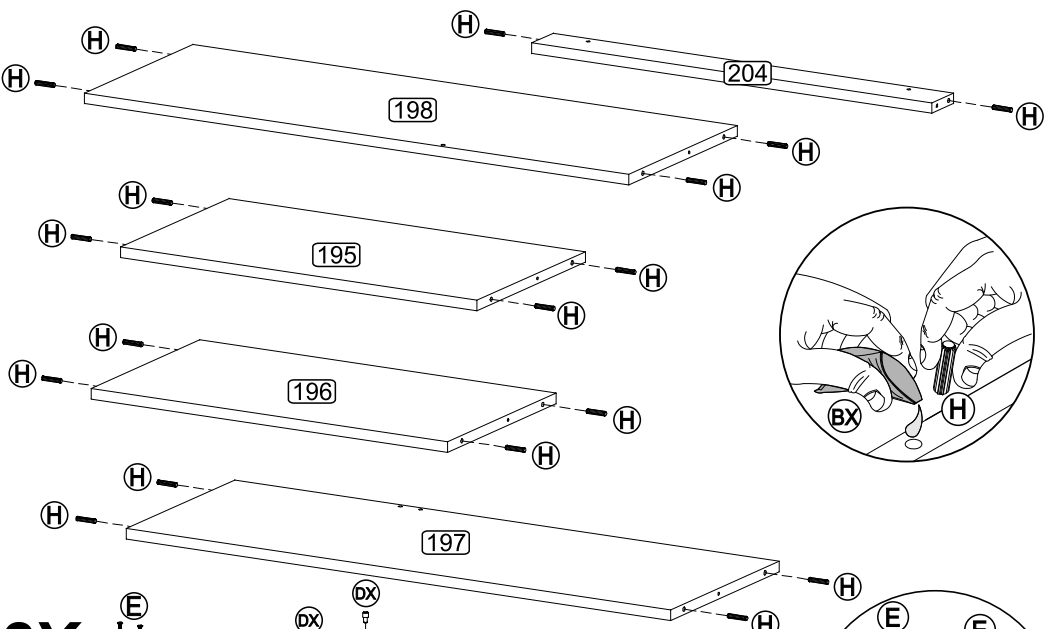

Passo
Paso
Step **01**

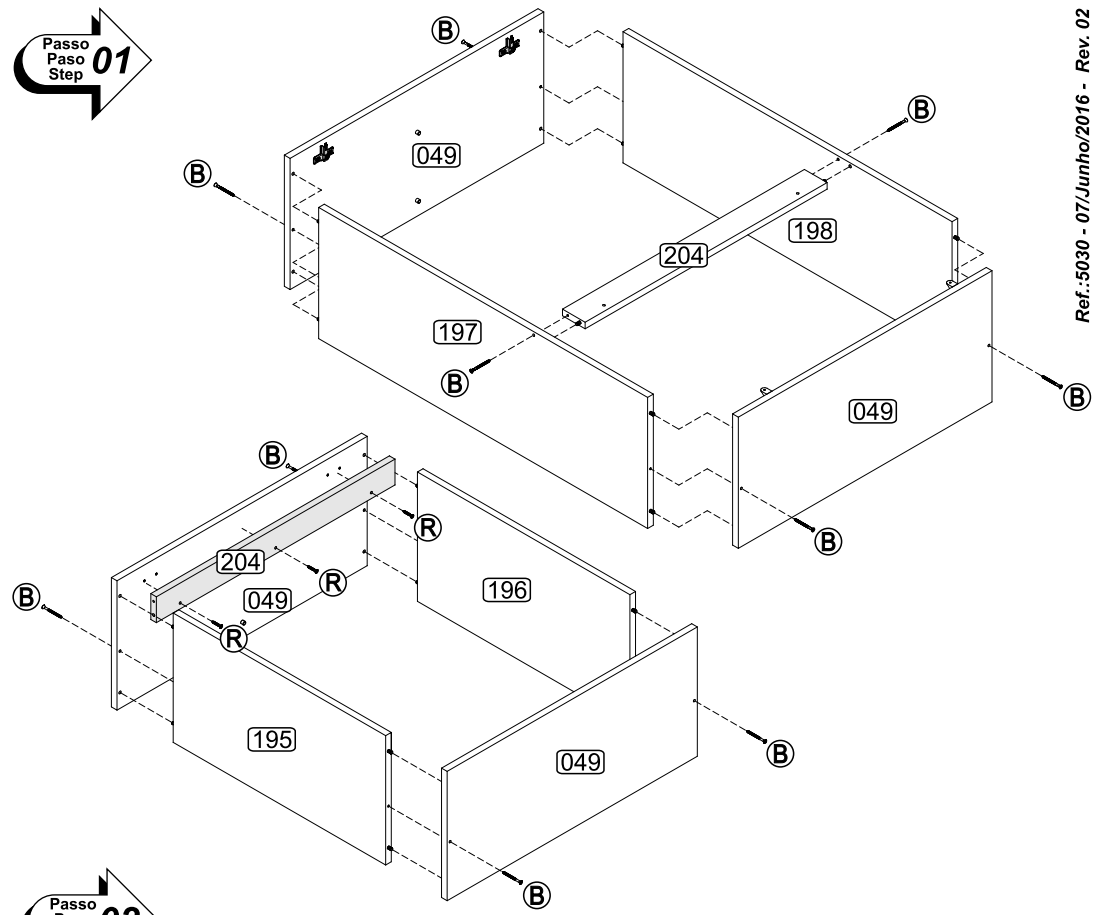

Passo
Paso
Step **02**

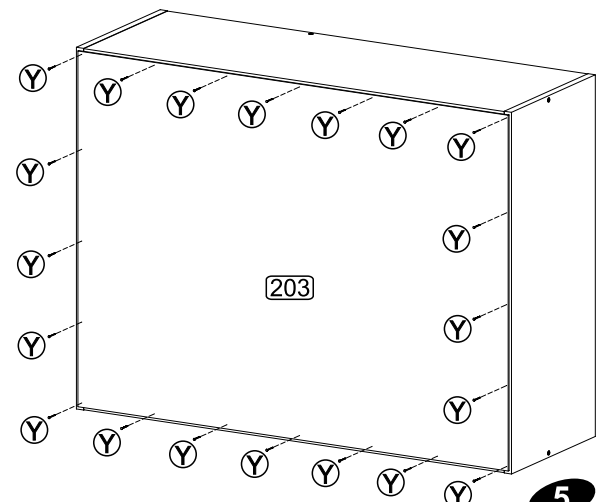
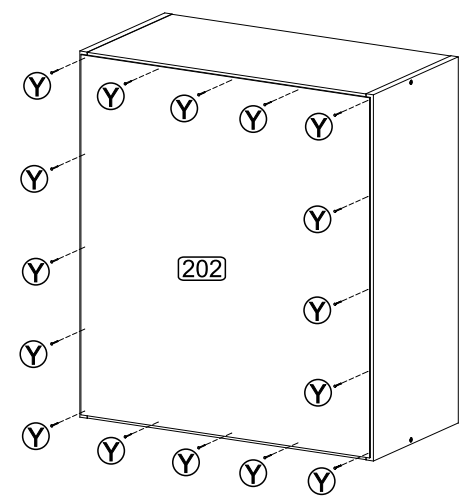

4

5