

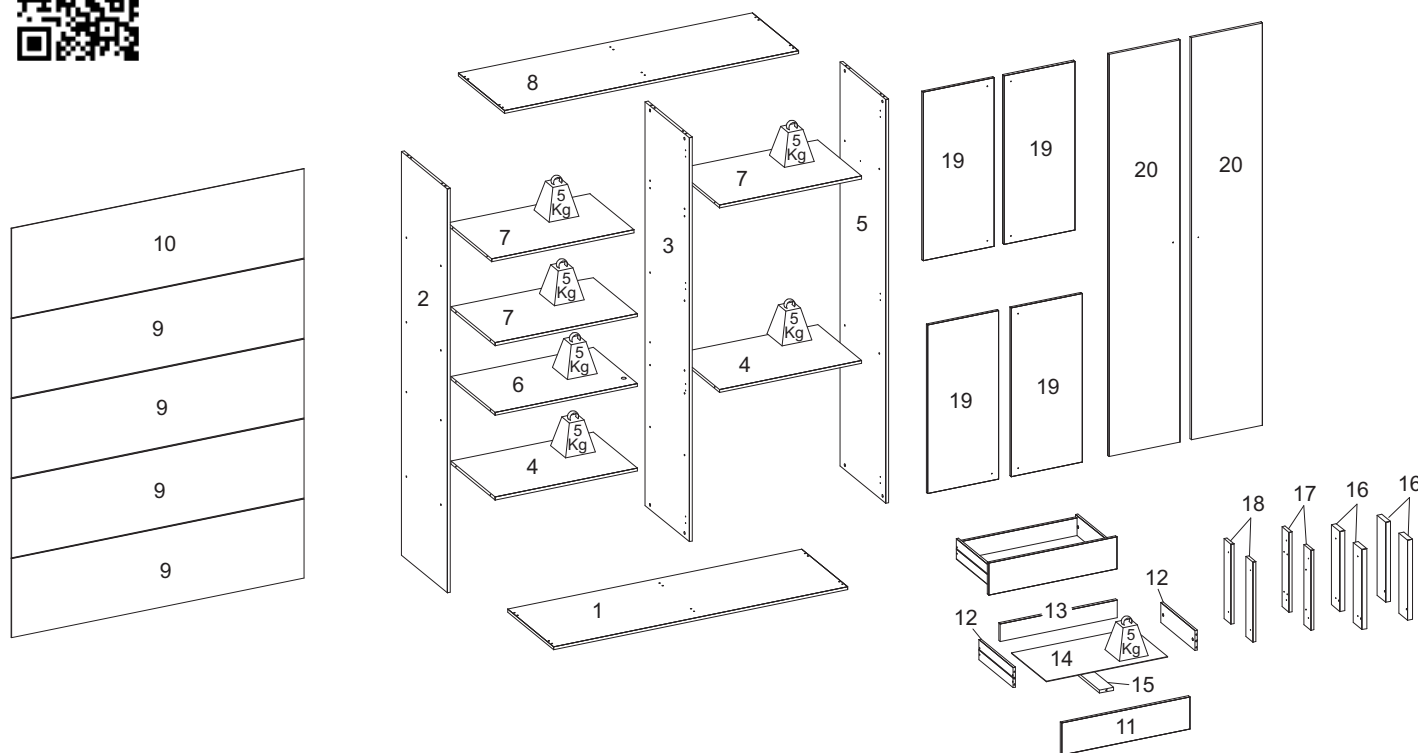

328 - Gr Vittoria



LISTA DE PEÇAS / PIECES LIST / LISTA DE PIEZAS

SEQ.	REF.	DESCRIÇÃO	DESCRIPTION	DESCRIPCIÓN	MAT.PRIMA	COMP.	LARG.	ESP.	QTD.
1	333076	Base	Base	Base	MDP	1500	470	15	1
2	333077	Lateral esquerda	Left side panel	Panel lateral izquierdo	MDP	2020	468	15	1
3	333078	Divisória	Divider	Divisor	MDP	2020	450	15	1
4	333079	Prateleira inferior	Lower shelf	Estante inferior	MDP	726	450	15	2
5	333080	Lateral direita	Right divider	Divisor derecho	MDP	2020	468	15	1
6	333081	Tampo	Top	Tampo	MDP	726	450	15	1
7	333082	Prateleira superior	Top shelf	Estante superior	MDP	726	450	15	3
8	333083	Chapéu	Top panel	Panel superior	MDP	1500	470	15	1
9	333084	Fundo inferior	Bottom fund	Fondo inferior	HDF	1493	395	3	4
10	333085	Fundo superior	Top fund	Fondo superior	MDP	1493	447	3	1
11	333086	Frente de gaveta	Drawer front	Frente del cajón	MDP	654	160	15	2
12	333087	Lateral de gaveta	Drawer side	Lateral del cajón	MDP	350	100	12	4
13	333088	Contra fundo	Back	Parte trasera	MDP	597	88	15	2
14	333089	Fundo da gaveta	Drawer bottom	Parte inferior del cajón	HDF	619	355	3	2
15	333090	Apoio de gaveta	Drawer support	Soporte para cajón	MDP	350	72	15	2
16	333091	Distanciador gaveta	Drawer spacer	Separador de cajones	MDP	400	88	25	4
17	333092	Batente direito gaveta	Right drawer stop	Guión derecho cajón	MDP	400	72	15	2
18	333093	Batente esquerdo gaveta	Left drawer stop	Golpe a la izquierda	MDP	400	72	15	2
19	333094	Porta menor	Smallest door	Guión izquierdo cajón	MDP	843	362	15	4
20	333095	Porta	Door	Puerta	MDP	2012	362	15	2

INSTRUÇÃO MONTAGEM PRODUTO

Intructions to Assembly / Instrucciones de montaje

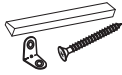

Separar as peças e acessórios de maneira organizada
Separate parts and accessories in way organized
Separar las piezas y accesorios de manera organizada

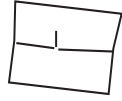

Forrar o chão com o papelão das embalagens.
Cover the floor with the cardboard
Cubra el suelo con la embalaje de cartón



É necessário 01 pessoa para montar o produto
01 people are required to assemble the product
Se requieren 01 persona para ensamblar el producto

O produto deve ser a montado por um profissional qualificado
The product must be assembly by a professional
El producto debe ser ensamblado por un profesional calificado

Ferramentas necessárias
(não fornecidas)

Not include tools / No herramientas



CUIDADO PARA CONSERVAÇÃO E LIMPEZA DO MÓVEL

Care to conservation and clean / Cuidados de limpieza

Peso máximo de carga informado refere-se a objetos distribuído de maneira uniforme sobre toda área de contato da peça



The maximum load weight informed refers to objects distributed evenly over the entire contact area of the part
Conjunto de carga máxima de peso se refere a objetos distribuídos uniformemente sobre toda el área de contacto de la pieza de trabajo.



Não molhar o móvel e não expor em lugar úmido
Do not wet the mobile and do not expose in a wet place
No moje el producto y no exponer en un lugar húmedo



Não expor o móvel próximo de fontes de calor.
Do not expose the mobile near heat sources
no exponga cercano de fuentes de calor



Não usar produtos abrasivos.
Do not use abrasive products.
No utilice productos abrasivos.



Limpe com flanela limpa e seca.
Clean with dry cloth
Limpieza con un paño limpio y seco



Para limpar os carimbos das peças utilize uma borracha escolar (item não fornecido)

Para clean the stamps on the pieces use a school eraser (item not provided)

Para limpiar los sellos de las piezas utilice un borrador escolar (artículo no incluido)

LISTA DE ACESSÓRIOS E FERRAGENS / ACCESSORIES AND HARDWARE / ACCESORIOS Y HARDWARE



A - 700137 - Parafuso 4,5x45 (24x)
screw / tornillo



B- 700124 - Parafuso 3,5x25 (24x)
screw / tornillo



C- 700121 - Parafuso 3,5x12 (56x)
screw / tornillo

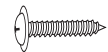

D- 700126 Parafuso 4,0x12 (84x)
screw / tornillo



E - 700516 - Satche cola 20g (1x)
Glue / Goma



F- 700136-Parafuso 4,5x35 (14x)
screw / tornillo



G- 700146 - Parafuso minifix (16x)
Minifix screw /
Tornillo minifix



H- 700148
Tambor Minifix (16x)
Minifix Drum /
Tambor minifix



I - 700542 - Cavilha 6x30 (22x)
peg / cerrojo



J- 701333-Dobradiça curva
c/ pistão + calço (7x)
hinge / bisagra



K - 700113 - Corrediça (2x)
runners / corredera



L- 702941-Dobradiça super curva
c/ pistão + calço (7x)
hinge / bisagra



M - 700433-Suporte angular (2x)
Angled support / Soporte en ángulo



N-700438 - Suporte cabide (2X)
hook support / soporte gancho



O- 703413-Puxador (6x)
handle / manija



P- 700157
Prego (123x)
nail / clavo



Q - 700533-Pé (6x)
foot/pie



R- 703874 - Perfil H (8x)
Frame / Perfil



S - 703875 - Cabideiro Aluminio (1x)
Coat Rack / Perchero



T- 700419 - Tapa furo minifix (32x)
minifix cover / tapa minifix

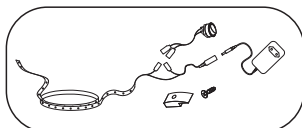

U - 703878 - Kit Led (01x)
LED kit./ kit led.

01° PASSO - Fazer a separação das corredeira

01° STEP - Separate the slides

01° PASO - Separar las diapositivas

K

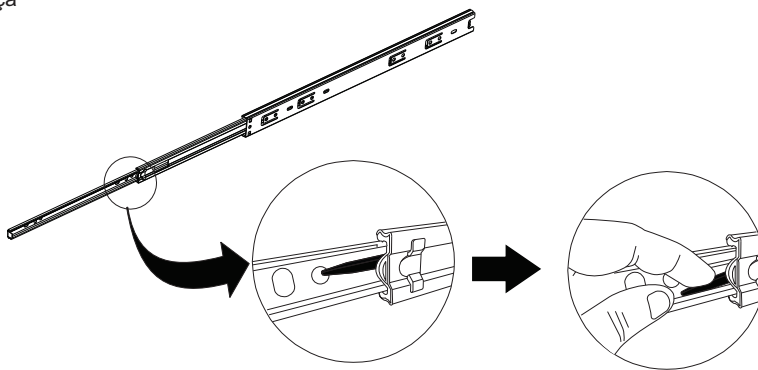

**Abaixe a alça preta e retire a peça conforme abaixo.
Push the black pin down to remove the D1 part.
Empujar para abajo la pieza negra para retirar la parte D1.**



K1

K2

02° PASSO - Fixar peças 17 e 18 nas peças 16.

02° STEP - Fix parts 17 and 18 to parts 16.

02° PASO - Fijar las piezas 17 y 18 a las piezas 16.

B

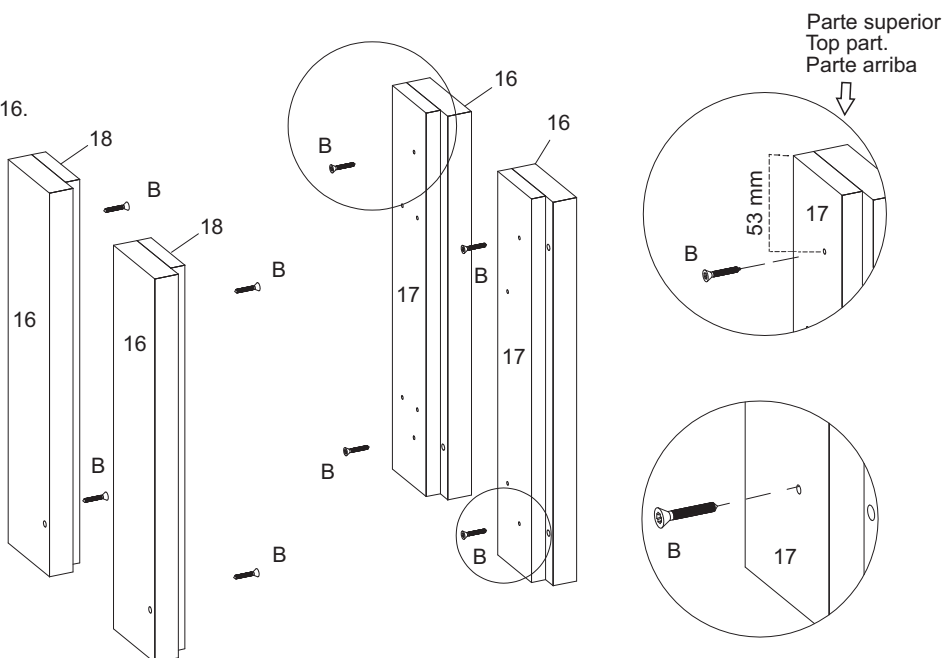

03° PASSO - Fixar os acessórios nas peças 17 e 18.

03° STEP - Fix the accessories to parts 17 and 18.

03° PASO - Fijar los accesorios en las piezas 17 y 18. 4

C



K2

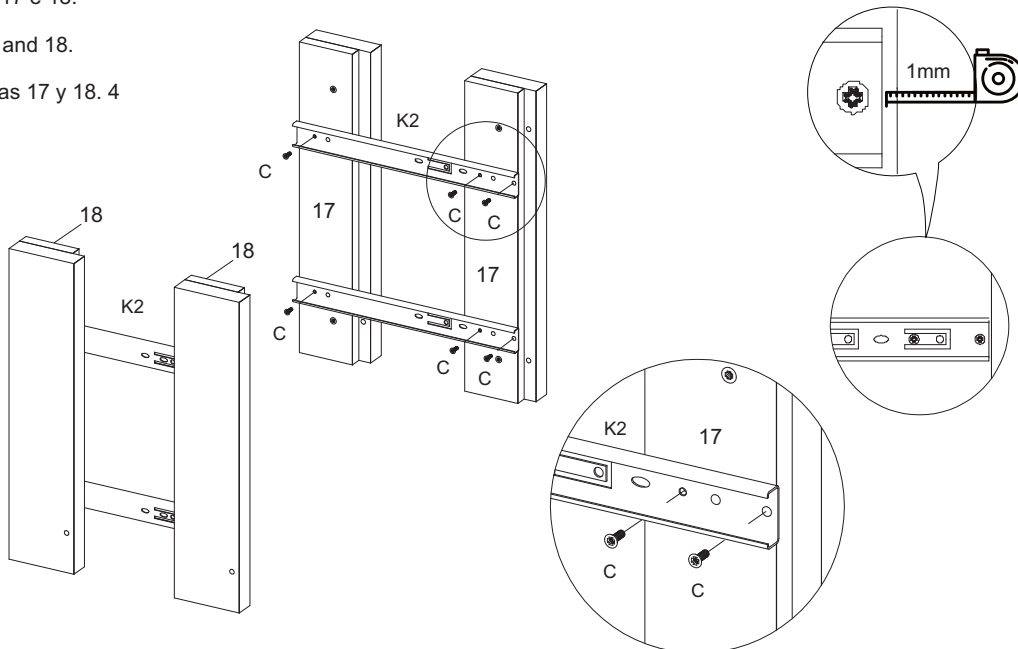

04° PASSO - Fixar os acessórios nas peça 1.

04° STEP - Fix the accessories to part 1.

04° PASO - Fijar los accesorios en la pieza 1.

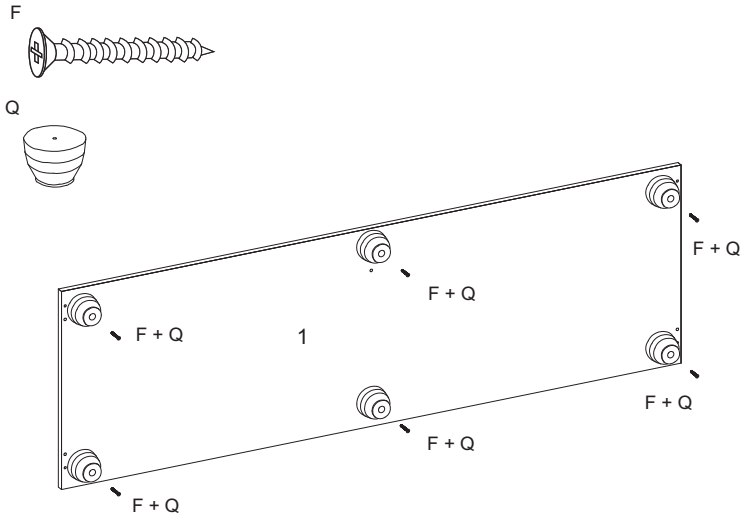

05° PASSO - Fixar peças 2 e 3 na peça 1.

05° STEP - Fix parts 2 and 3 to part 1.

05° PASO - Fijar las piezas 2 y 3 a la pieza 1.

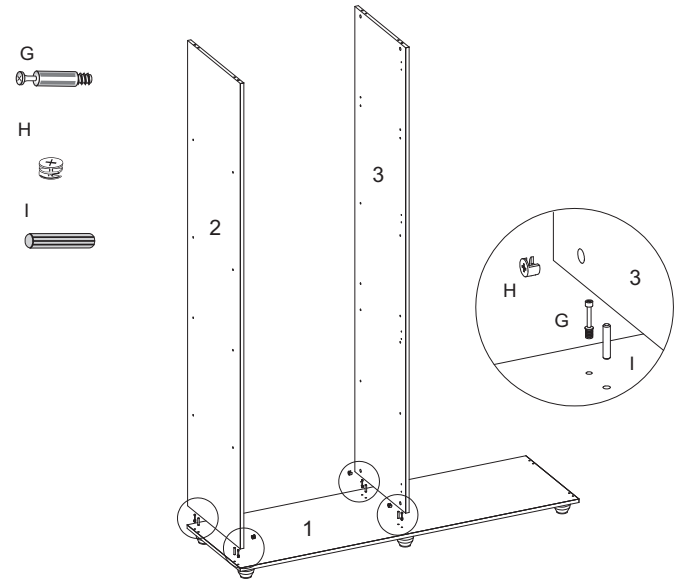

06° PASSO - Fixar peça 4 nas peças 2 e 3.

06° STEP - Fix part 4 to parts 2 and 3.

06° PASO - Fijar la pieza 4 a las piezas 2 y 3.

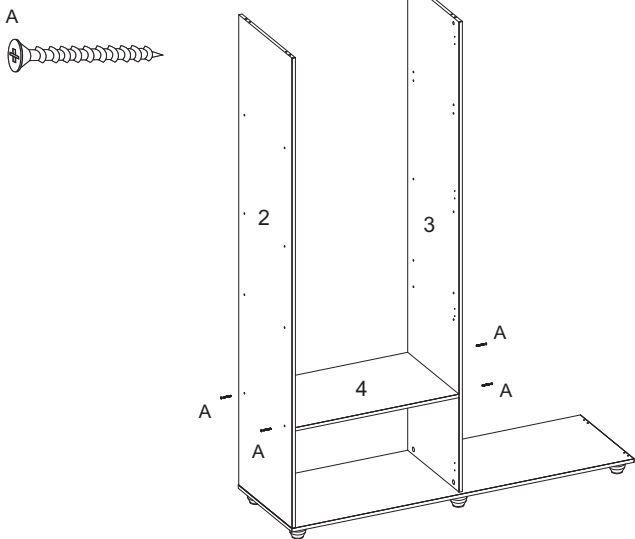

07° PASSO - Fixar peça 4 e 5 nas peças 1 e 3.

07° STEP - Fix parts 4 and 5 to parts 1 and 3.

07° PASO - Fijar las piezas 4 y 5 a las piezas 1 y 3.

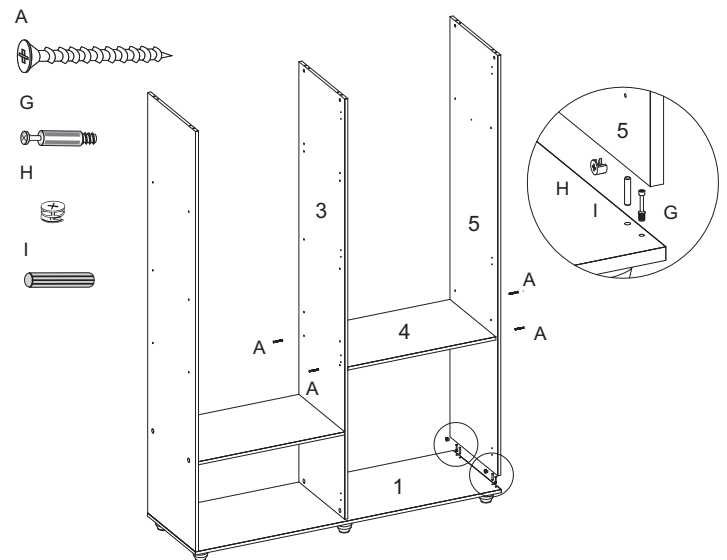

08° PASSO - Fixar peças 6 e 7 nas peças 2,3 e 5.

08° STEP - Fix parts 6 and 7 to parts 2, 3, and 5.

08° PASO - Fijar las piezas 6 y 7 a las piezas 2, 3 y 5.

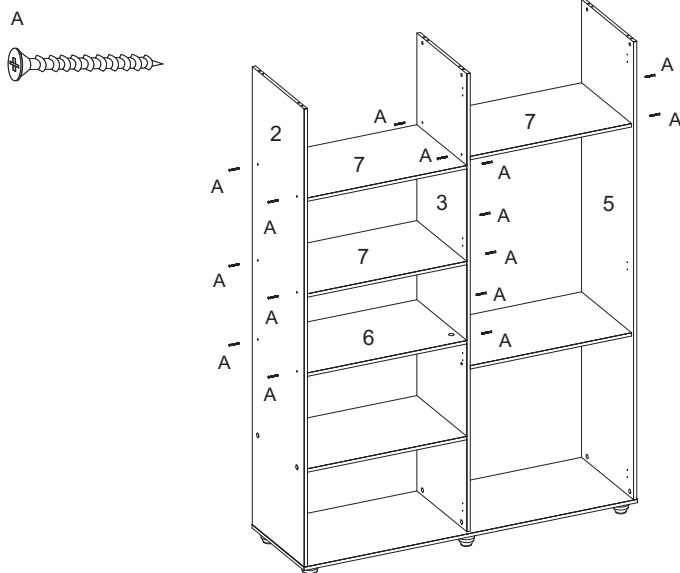

09° PASSO - Fixar peça 8 nas peças 2,3 e 5.

09° STEP - Fix parts 6 and 7 to parts 2, 3, and 5.

09° PASO - Fijar las piezas 6 y 7 a las piezas 2, 3 y 5.

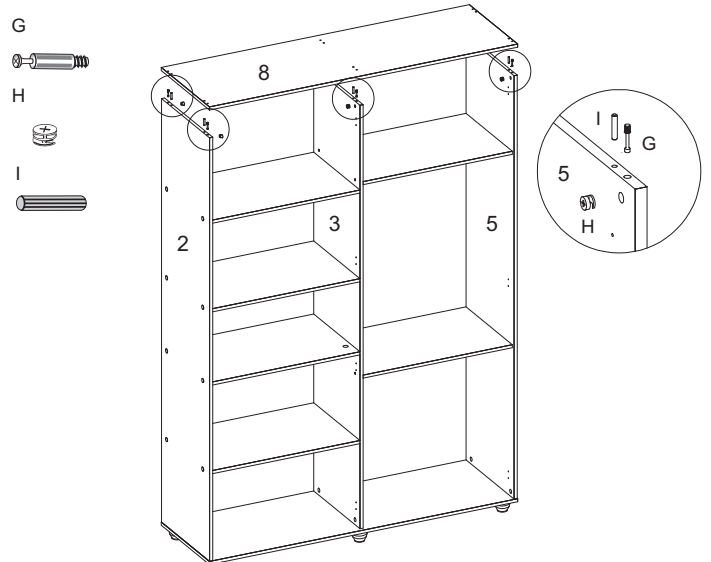

10° PASSO - Fixar peças 9 e 10 atrás do produto.

10° STEP - Fix parts 9 and 10 to the back of the product.

10° PASO - Fijar las piezas 9 y 10 detrás del producto.

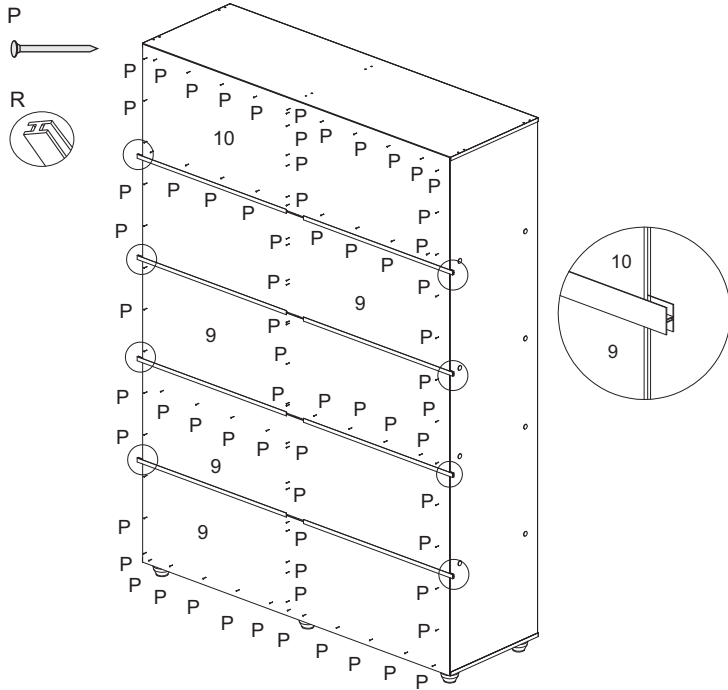

11° PASSO - Fixar peça 16 nas peças 3 e 5.

11° STEP - Fix part 16 to parts 3 and 5.

11° PASO - Fijar la pieza 16 a las piezas 3 y 5.

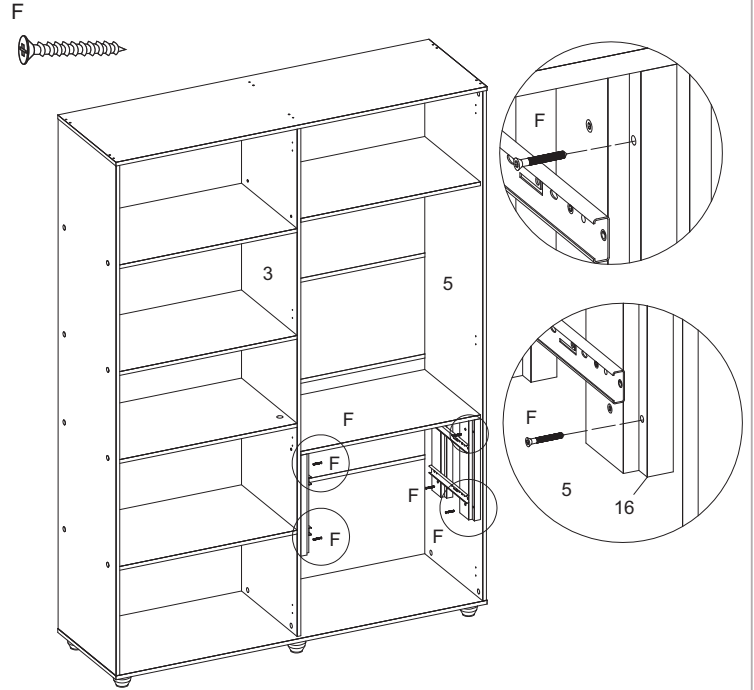

12° PASSO - Fixar o kit led.

12° STEP - Secure the LED kit.

12° PASO - Fijar el kit LED.

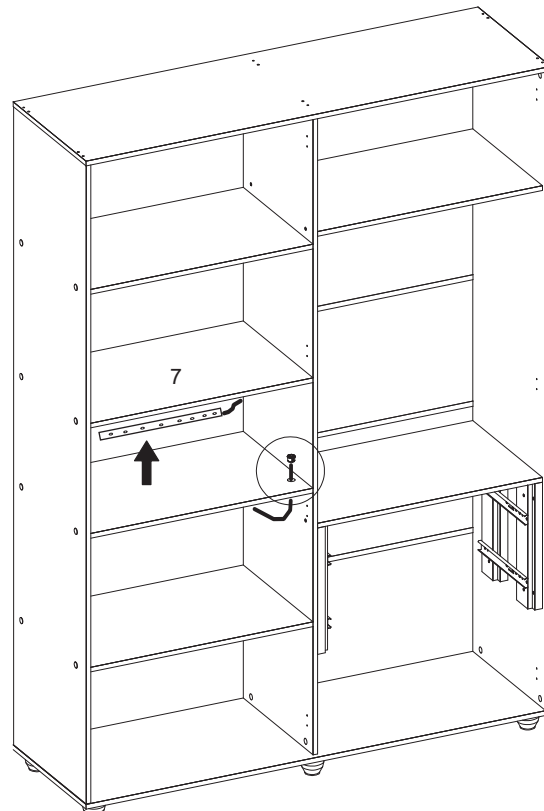
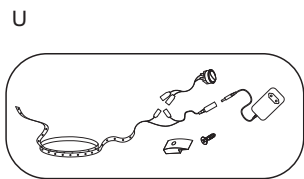

Instale o botão do LED no tampo.
Install the LED button on the top.
Instale el botón LED en la tapa.

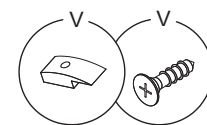

Cole a fita do led embaixo da prateleira 7.

Stick the LED strip underneath from shelf 7

Pega la cinta LED debajo de la estantería 7.

Utilize o acessório acima para fixar/organizar a fiação do LED.

Use the accessory above to fix/organize the LED wiring.

Utilice el accesorio anterior para fijar/organizar el cableado del LED.

13° PASSO- Passar o fio do led entre os perfil H.

13° STEP - Pass the LED wire between the H profiles

13° PASO - Pasar el cable del led entre los perfiles H.

U

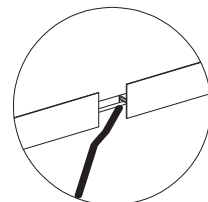
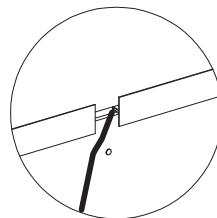
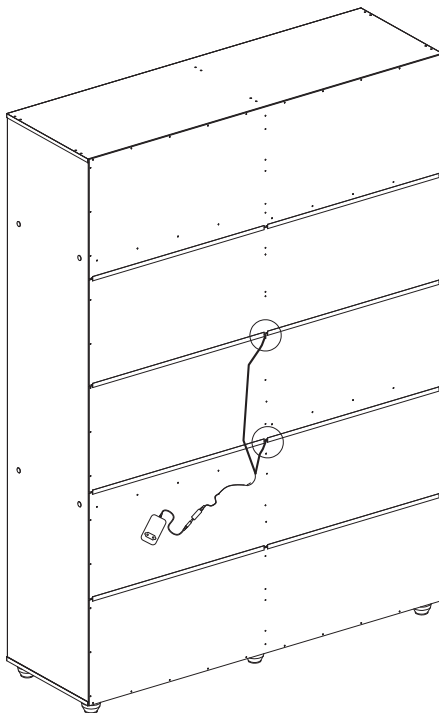
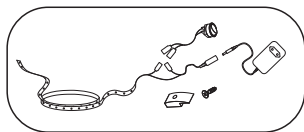

14° PASSO- Fixar o acessório nas peças 3 e 5.

14° STEP - Fix the accessory to parts 3 and 5.

14° PASO - Fijar el accesorio en las piezas 3 y 5.

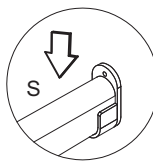
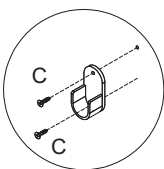
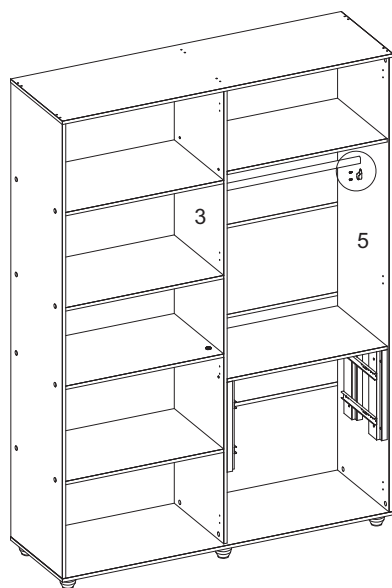
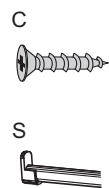

15° PASSO - Fixar peças 12 nas peças 11 e 13.

15° STEP - Fix parts 12 to parts 11 and 13.

15° PASO - Fijar las piezas 12 a las piezas 11 y 13.

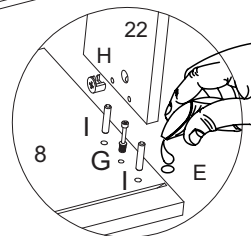
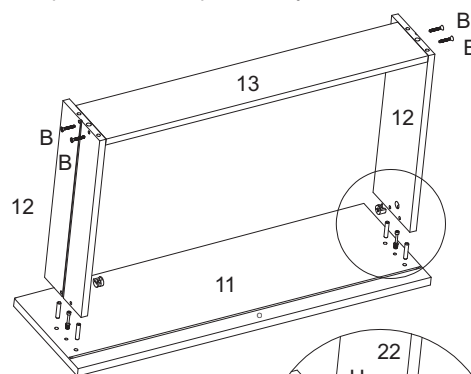
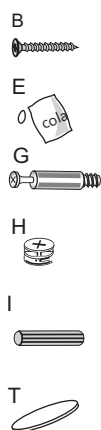

16° PASSO - Fixar peça 14 nas peças 12 e 13.

16° STEP - Fix part 14 to parts 12 and 13.

16° PASO - Fijar la pieza 14 a las piezas 12 y 13.

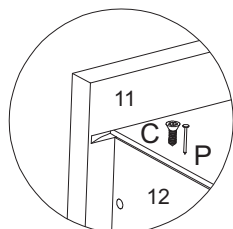
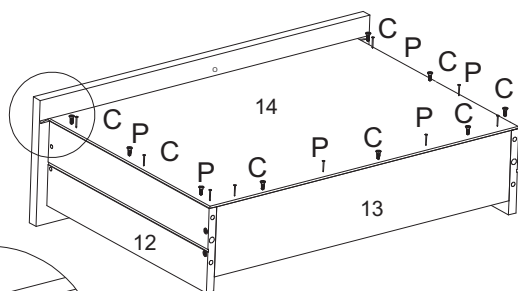
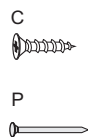

17° PASSO - Fixar peça 15 na peça 13

17° STEP - Fix part 15 to part 13.

17° PASO - Fijar la pieza 15 a la pieza 13.

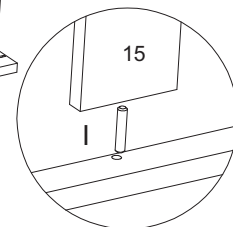
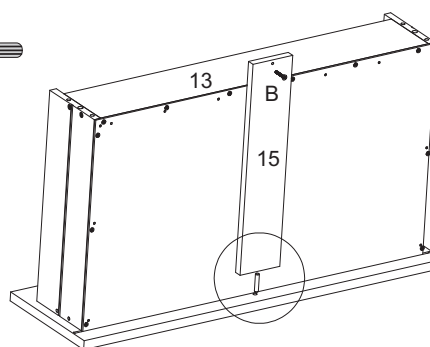
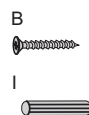

18° PASSO - Fixar acessório (C+K1) na peças 12 e (C+M) nas peças 11 e 15

18° STEP - Fix accessory (C+K1) to part 12 and (C + M) to parts 11 and 15

18° PASO - Fijar el accesorio (C+K1) a la pieza 12 y (C + M) a las piezas 11 y 15

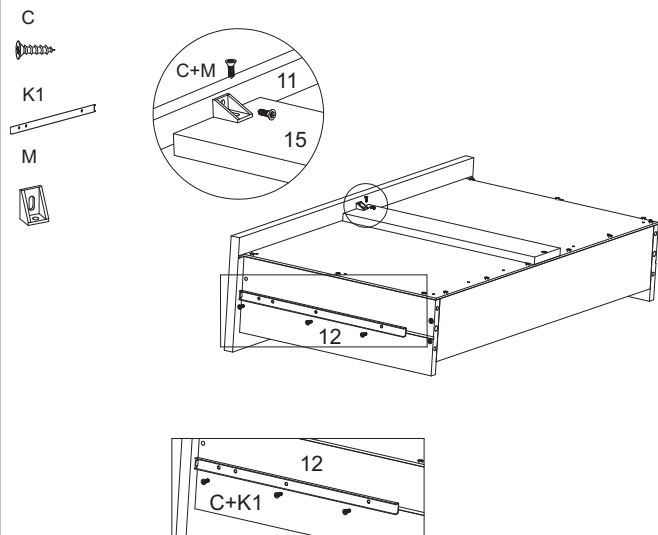

19° PASSO - Encaixar as gavetas no produto.

19° STEP - Fit the drawers into the product.

19° PASO - Encajar los cajones en el producto.

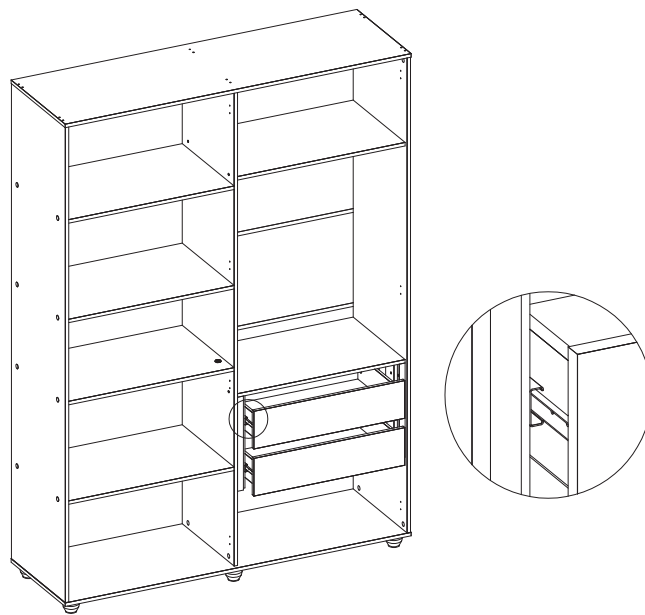

20° PASSO - Fixar os acessórios (D+J) na peças 19 e 20.

20° STEP - Fix the accessories (D+J) to parts 19 and 20.

20° PASO - Fijar los accesorios (D+J) en las piezas 19 y 20.

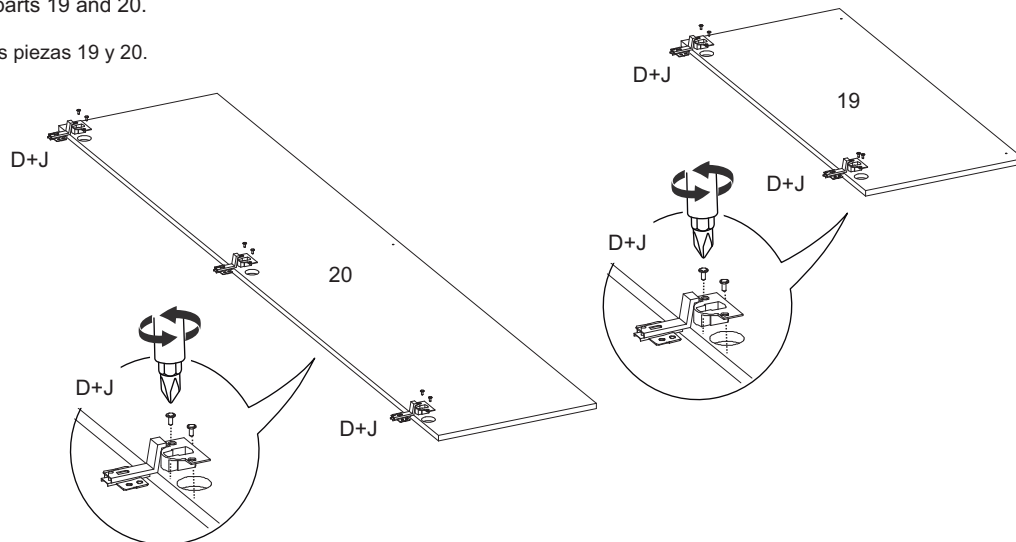
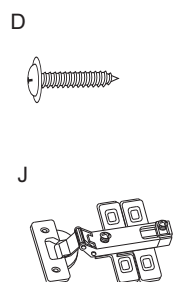

20° PASSO - Fixar as peças 19 e 20.

20° STEP - Fix parts 19 and 20.

20° PASO - Fijar las piezas 19 y 20.

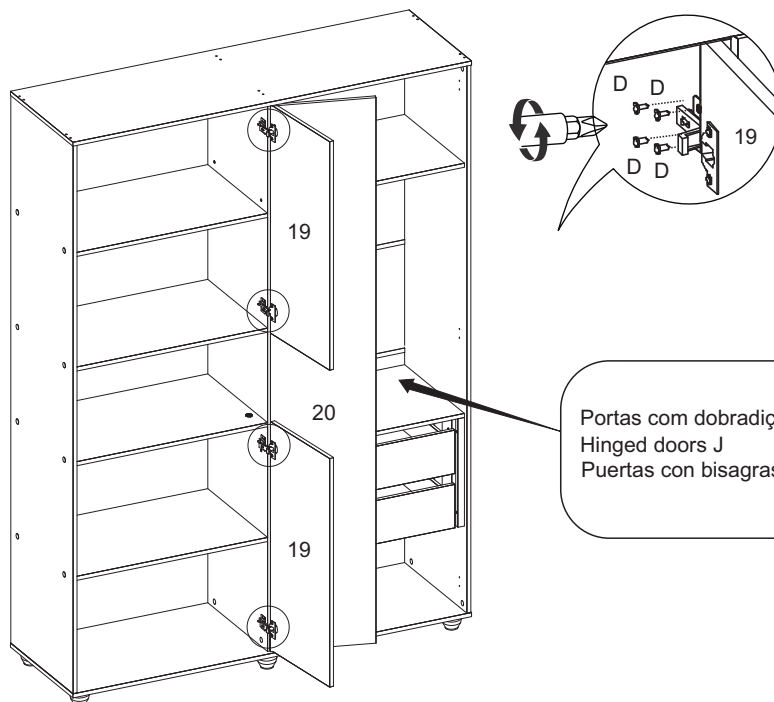
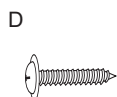

21° PASSO - Fixar os acessórios (D+L) na peças 19 e 20.

21° STEP - Fix the accessories (D+L) to parts 19 and 20.

21° PASO - Fijar los accesorios (D+L) en las piezas 19 y 20.

D



L

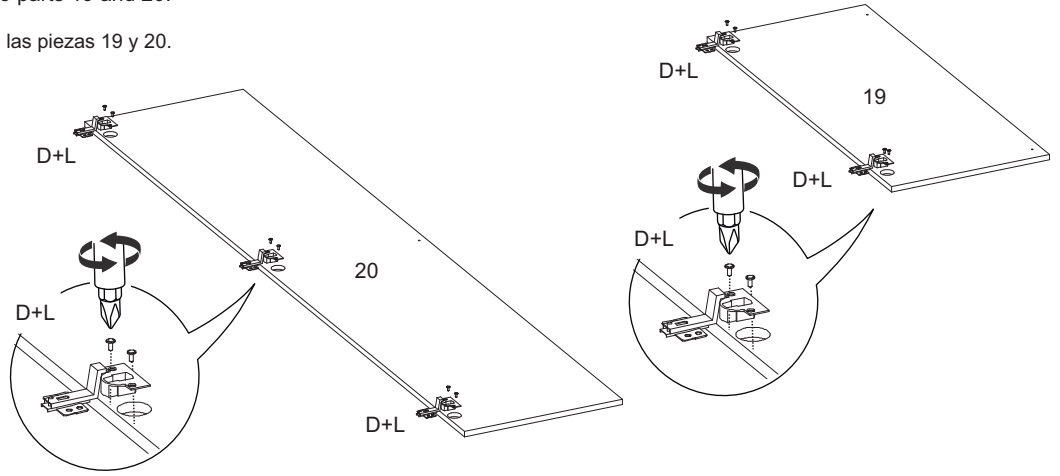
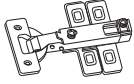

22° PASSO - Fixar as peças 19 e 20.

22° STEP - Fix parts 19 and 20.

22° PASO - Fijar las piezas 19 y 20.

D

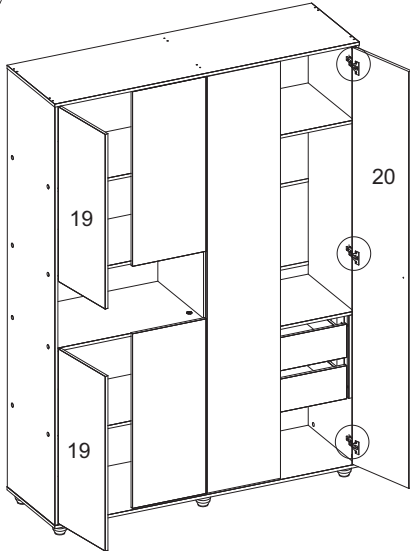
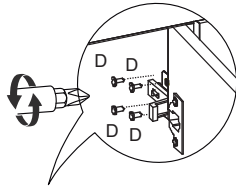

Portas com dobradiça L
Hinged doors L
Puertas con bisagras L

23° PASSO - Fixar os acessórios nas peças 19 e 20.

23° STEP - Fix the accessories to parts 19 and 20.

23° PASO - Fijar los accesorios en las piezas 19 y 20.

B



O

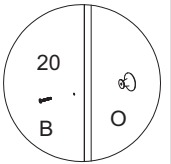
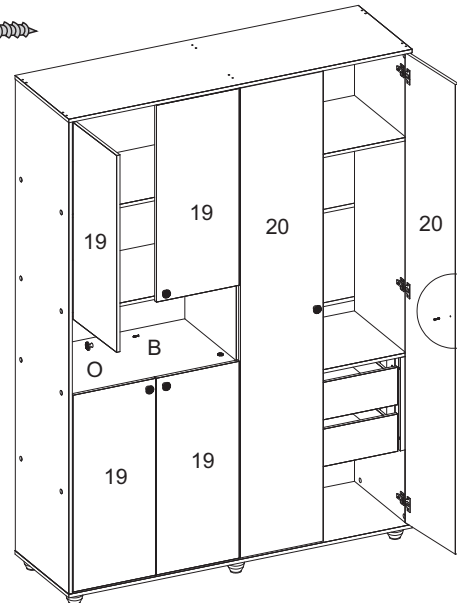

Aspecto final do produto

Final product aspect

Aspecto final del producto

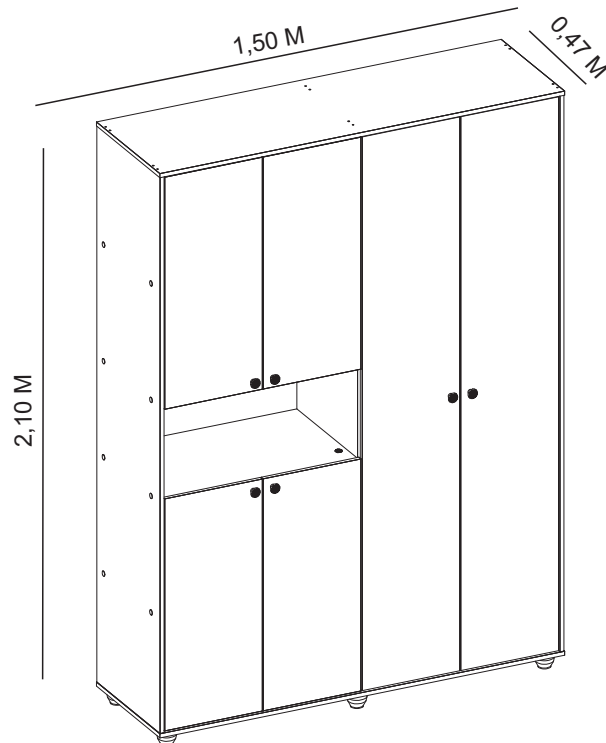



1080 - COMODA VITTORIA

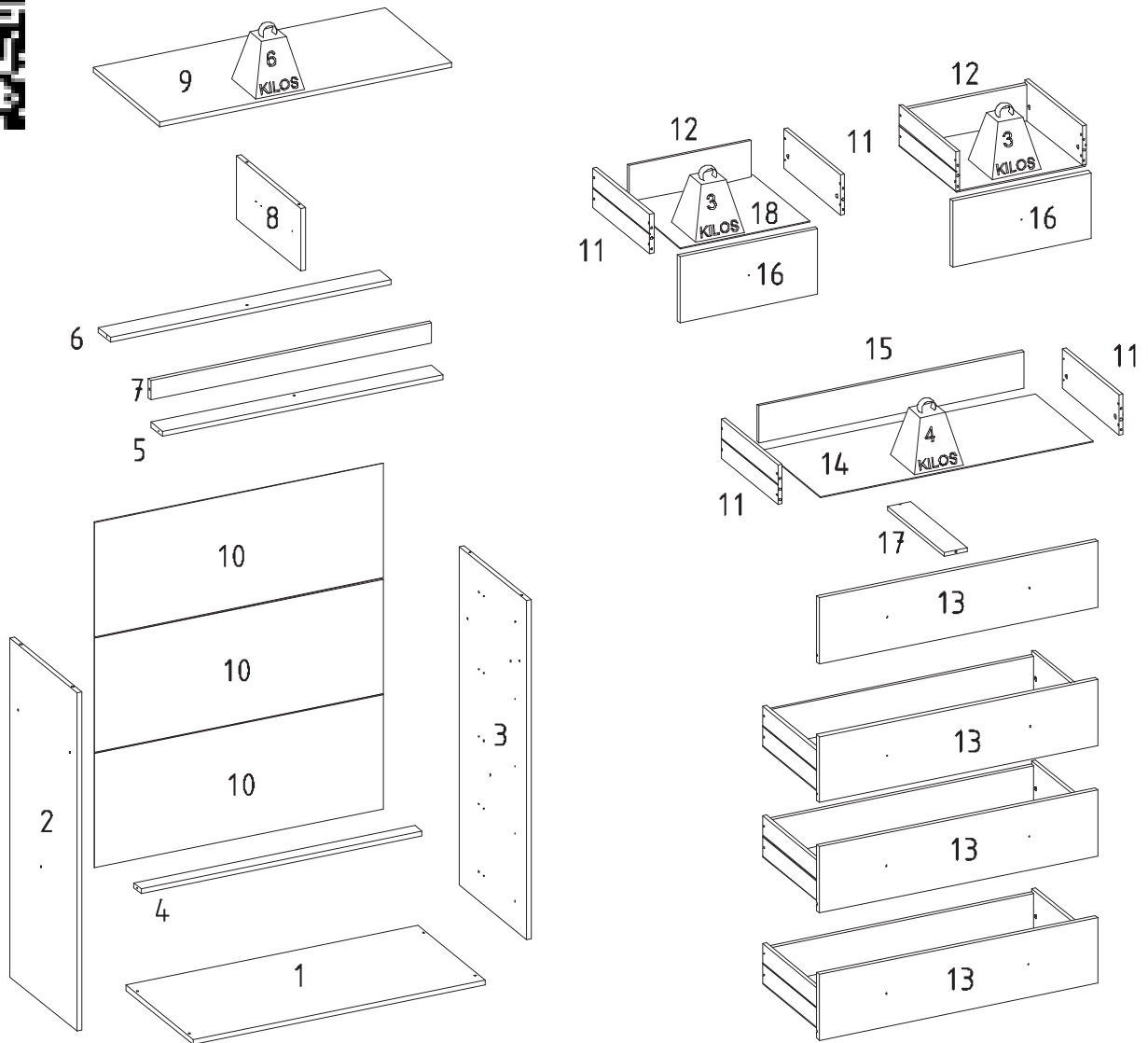

LISTA DE PEÇAS / Pieces List / Lista de Piezas

SEQ.	REF.	DESCRIÇÃO	DESCRIPTION	DESCRIPCIÓN	MAT.PRIMA	COMP.	LARG.	ESP.	QTD.
1	315955	Base	Base	Base	MDP	900	410	15	1
2	315956	Lateral esquerda	Left side	Lado izquierdo	MDP	1022	410	15	1
3	315957	Lateral direita	Right side	Lado derecho	MDP	1022	410	15	1
4	315958	Trava gaveta	Drawer lock	Cerradura del cajón	MDP	866	44	15	1
5	315959	Travessa frontal	Traverse frontal	Traverse frontal	MDP	866	72	15	1
6	315960	Travessa traseira	Rear Tray	Bandeja trasera	MDP	866	72	15	1
7	315961	Trava da vista	View lock	Ver bloqueo	MDP	866	60	15	1
8	315962	Divisoria	Partition	Partición	MDP	394	190	15	1
9	315963	Tampo	Cover	Caja de resonancia	MDP	900	412	15	1
10	315964	Fundo	Bottom	Antecedentes	HDF	890	345	3	3
11	700531	Lateral gaveta	Side drawer	Cajón lateral	MDP	350	120	12	12
12	315967	Contra fundo menor	Against smaller background	Contra un fondo más pequeño	MDP	377	110	12	2
13	315968	Frente gaveta	Drawer front	Frente del cajón	MDP	858	199	15	4
14	315969	Fundo gaveta	Bottom drawer	Cajón inferior	HDF	839	355	3	4
15	315970	Contra fundo	Against background	Contra el fondo	MDP	817	110	12	4
16	315971	Frente gaveta menor	Smaller drawer front	Frente de cajón más pequeño	MDP	427	199	15	2
17	315972	Apoio de gaveta	Drawer support	Soporte de cajones	MDP	350	72	12	4
18	315973	Fundo gaveta menor	Smaller drawer bottom	Fondo de cajón más pequeño	HDF	399	350	3	2

INSTRUÇÃO MONTAGEM PRODUTO

Intructions to Assembly / Instrucciones de montaje

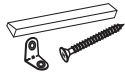

Separar as peças e acessórios de maneira organizada
Separate parts and accessories in way organized
Separar las piezas y accesorios de manera organizada

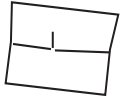

Forrar o chão com o papelão das embalagens.
Cover the floor with the cardboard
Cubra el suelo con la embalaje de cartón



É necessário 01 pessoa para montar o produto
01 people are required to assemble the product
Se requieren 01 persona para ensamblar el producto

O produto deve ser a montado por um profissional qualificado
The product must be assembly by a professional
El producto debe ser ensamblado por un professional calificado

Ferramentas necessárias
(não fornecidas)

Not include tools / No herramientas



CUIDADO PARA CONSERVAÇÃO E LIMPEZA DO MÓVEL

Care to conservation and clean / Cuidados de limpieza

Peso máximo de carga informado refere-se a objetos distribuído de maneira uniforme sobre toda área de contato da peça



The maximum load weight informed refers to objects distributed evenly over the entire contact area of the part

Conjunto de carga máxima de peso se refere a objetos distribuídos uniformemente sobre toda el área de contacto de la pieza de trabajo.



Não molhar o móvel e não expor em lugar úmido
Do not wet the mobile and do not expose in a wet place
No moje el producto y no exponer en un lugar húmedo



Não expor o móvel próximo de fontes de calor.
Do not expose the mobile near heat sources
no exponga cercano de fuentes de calor



Não usar produtos abrasivos.
Do not use abrasive products.
No utilice productos abrasivos.



Limpe com flanela limpa e seca.
Clean with dry cloth
Limpieza con un paño limpio y seco



Para limpar os carimbos das peças utilize uma borracha escolar (item não fornecido)

Para clean the stamps on the pieces use a school eraser (item not provided)

Para limpiar los sellos de las piezas utilice un borrador escolar (artículo não incluido)

DETALHAMENTO DETAL / DETALLES

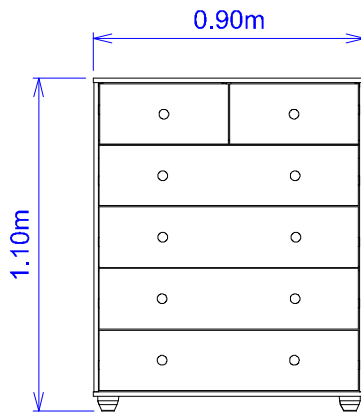

DETALHAMENTO DETAL / DETALLES

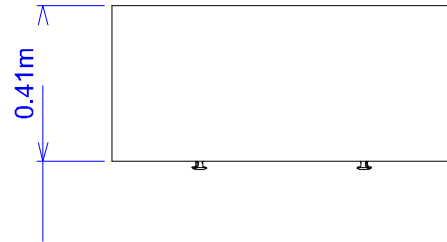

Dimensão do Produto: (L X A X P) 0.90X 1.10 X 0.40

LISTA DE ACESSÓRIOS E FERRAGEM / ACCESSORIES AND HARDWARE / ACCESORIOS Y EQUIPOS



A- 700137-Parafuso 4,5x45 (12x)
screw / tornillo



B- 700124-Parafuso 3,5x25 (38x)
screw / tornillo



C- 700121-Parafuso 3,5x12 (96x)
screw / tornillo



D- 700148-Tambor Minifix (12x)
Minifix Drum / Tambor minifix



E- 700146-Parafuso minifix (12x)
Minifix screw /
Tornillo minifix



F- 700542-Cavilha 6x30 (36x)
peg / cerrojo



G- 700538-Cantoneira (10x)
corner / esquina



H- 700157-Prego (109x)
nail / clavo



I - 700113-Corrediça (6x)
runners / corredera



J- 700533-Pé (4x)
foot/pie



K-700136-Parafuso 4,5x35 (4x)
screw/tornillo



L- 700532-Perfil H (2x)
Frame / Perfil



M- 700419-Tapa furo minifix (30x)
Minifix cover /
Tapa minifix



N- 703413-Puxador (10x)
handle / manija



O - 700433-Suporte angular (4x)
Angled support /
Soporte en ángulo



P- 700516-Sache cola 20g (1x)
Glue / Goma

01° PASSO Fixar peças 4,5 e 6 na peça 2

01° STEP Attach parts 4,5 and 6 to part 2

01° PASO Adjunte las partes 4,5 y 6 a la parte 2

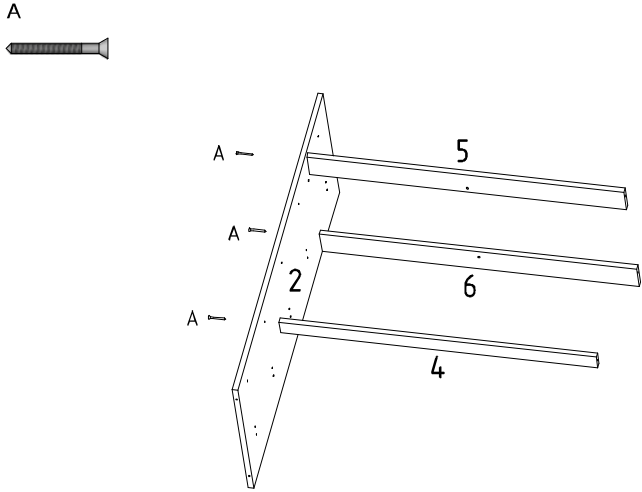

02° PASSO Fixar peças 4,5 e 6 na peça 3 , fixar peça 1 nas peças 2 e 3

02° STEP Attach parts 4,5 and 6 to part 3, fix part 1 to parts 2 and 3

02° PASO Adjunte las partes 4,5 y 6 a la parte 3, fije la parte 1 a las partes 2 y 3

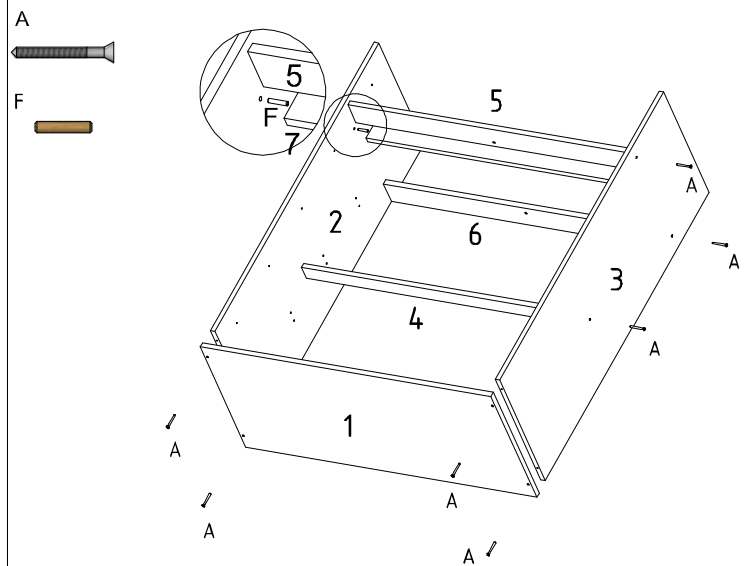

03° PASSO Fixar peça 7 na peça 5

03° STEP Attach part 7 to part 5

03° PASO Adjunte la parte 7 a la parte 5

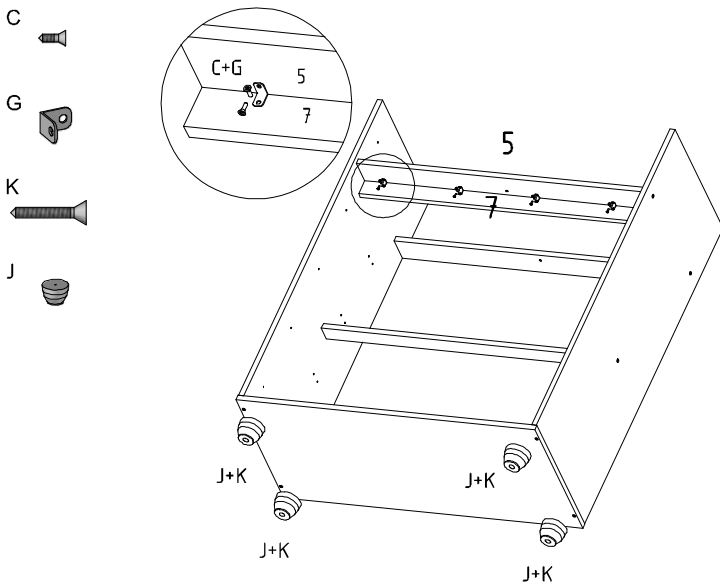

04° PASSO Fixar peça 8 nas peças 5 e 6

04° STEP Attach part 8 to parts 5 and 6

04° PASO Adjunte la parte 8 a las partes 5 y 6

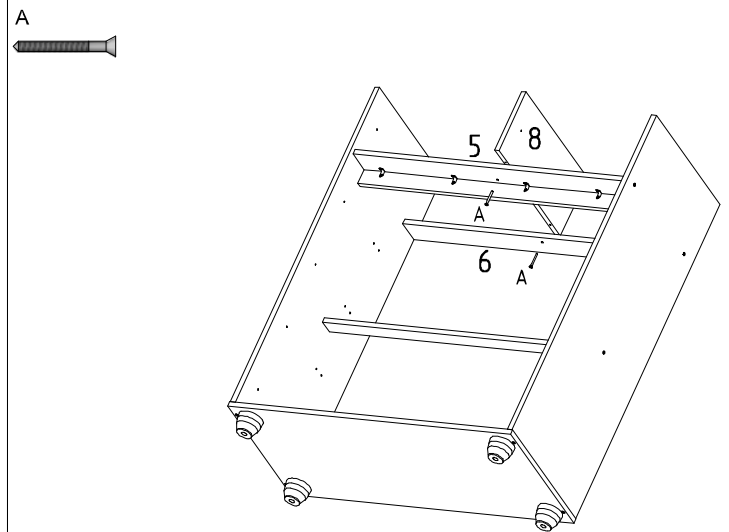

05° PASSO Fixar acessórios (C+I) nas peças 2,3 e 8

05° STEP Attach accessories (C + I) to parts 2,3 and 8

05° PASO Conecte los accesorios (C + I) a las partes 2,3 y 8

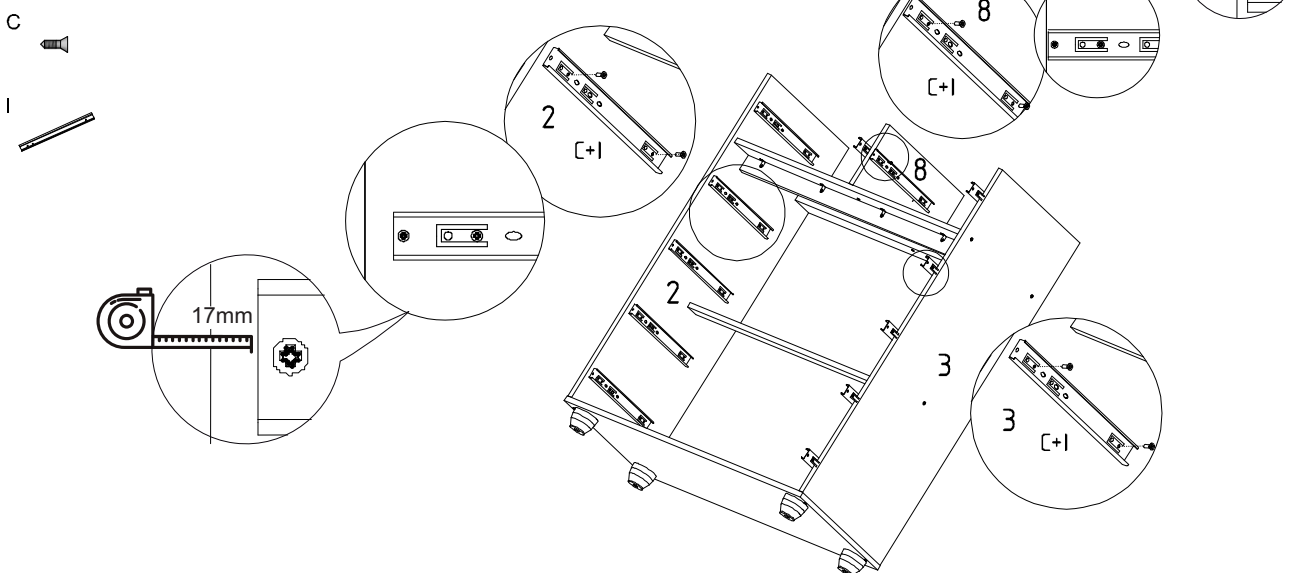

06° PASSO Fixar peça 9 nas peças 2,3 e 8

06° STEP Attach part 9 to parts 2,3 and 8

06° PASO Adjunte la parte 9 a las partes 2,3 y 8

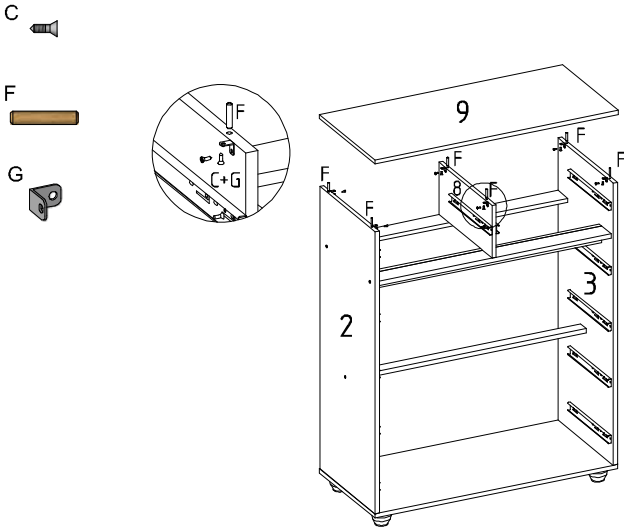

07° PASSO Fixar peça 10 no produto utilizando os acessórios (H+L+O)

07° STEP Attach part 10 to the product using the accessories (H + L + O)

07° PASO Conecte la parte 10 al producto utilizando los accesorios (H + L + O)

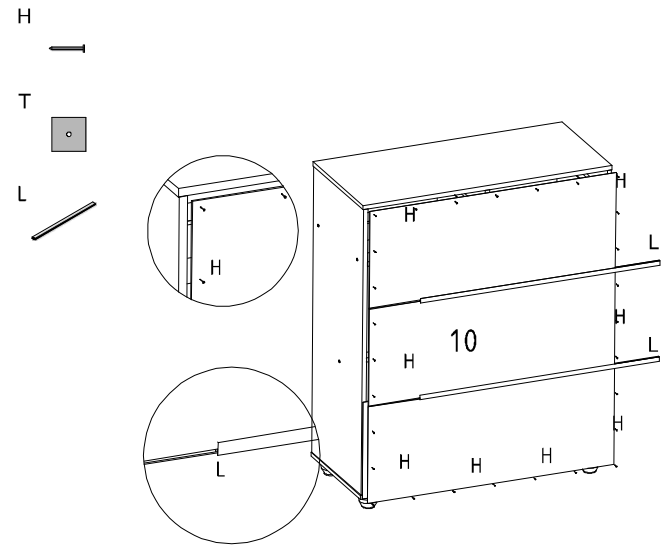

08° PASSO Fixar peças 11 nas peças 12 e 16 , fixar peça 18 nas peças 11 e 12

08° STEP Attach parts 11 to parts 12 and 16, fix part 18 to parts 11 and 12

08° PASO Conecte las partes 11 a las partes 12 y 16, fije la parte 18 a las partes 11 y 12

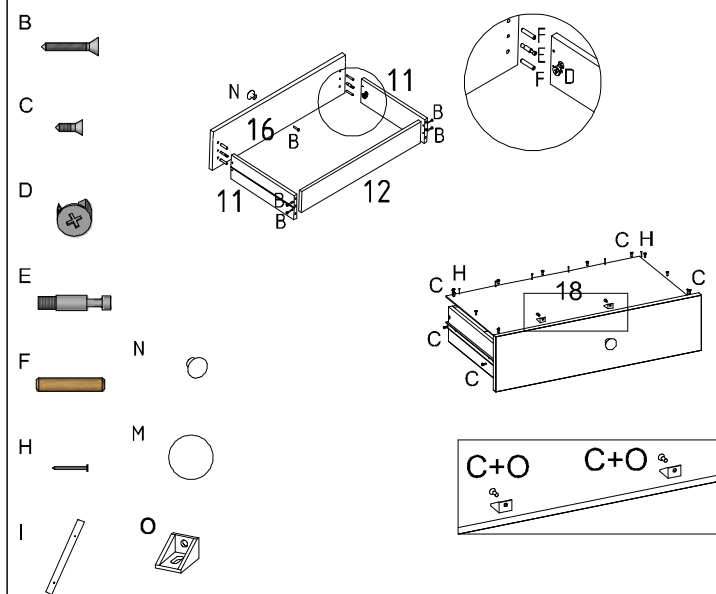

09° PASSO Fixar peças 11 nas peças 13 e 15 , fixar peças 14 e 17 na peças 11 e 15

09° STEP Attach parts 11 to parts 13 and 15, attach parts 14 and 17 to parts 11 and 15

09° PASO Conecte las partes 11 a las partes 13 y 15, fije las partes 14 y 17 a las partes 11 y 15

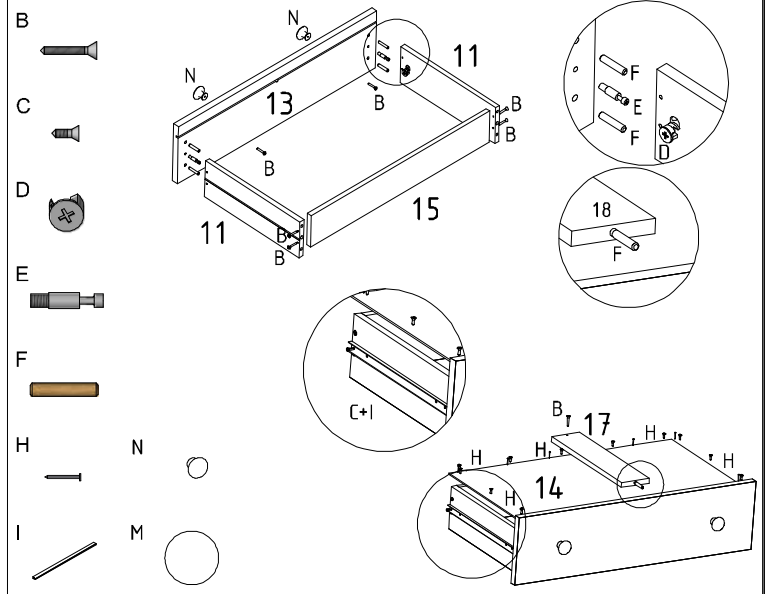

Aspecto final do produto

Final product aspect

Aspecto final del producto

