

ASSEMBLY INSTRUCTIONS MANUAL DE MONTAGEM / INSTRUCCIONES DE ARMADO

FRANÇA DRESSING TABLE

PENTEADEIRA FRANÇA

TOCADOR FRANÇA

Reference
Referência
Referencia

170487

Revisé
Revisão
Revisión

03



ENGLISH
PORTUGUÊS
ESPAÑOL

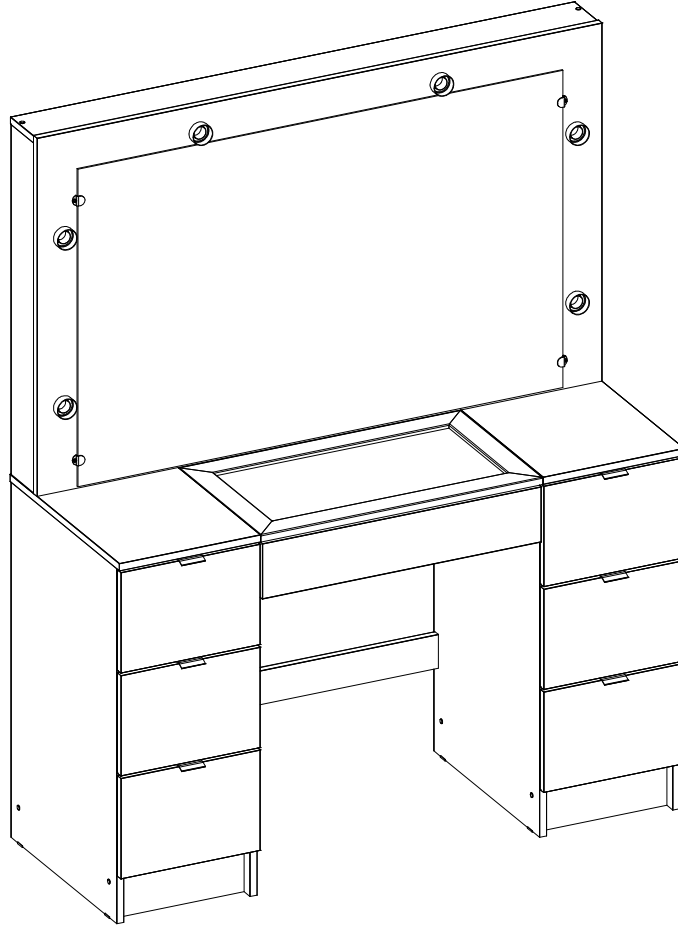

MAXIMUM RECOMMENDED WEIGHT
BEING THIS EVENLY DISTRIBUTED.

PESO MÁXIMO RECOMENDADO SENDO
ESTE DISTRIBUÍDO UNIFORMEMENTE.

PESO MÁXIMO RECOMENDADO SIENDO
ESTE UNIFORMEMENTE DISTRIBUIDO.

—	LB	KG
A	2	1
C	6	3
F	22	10

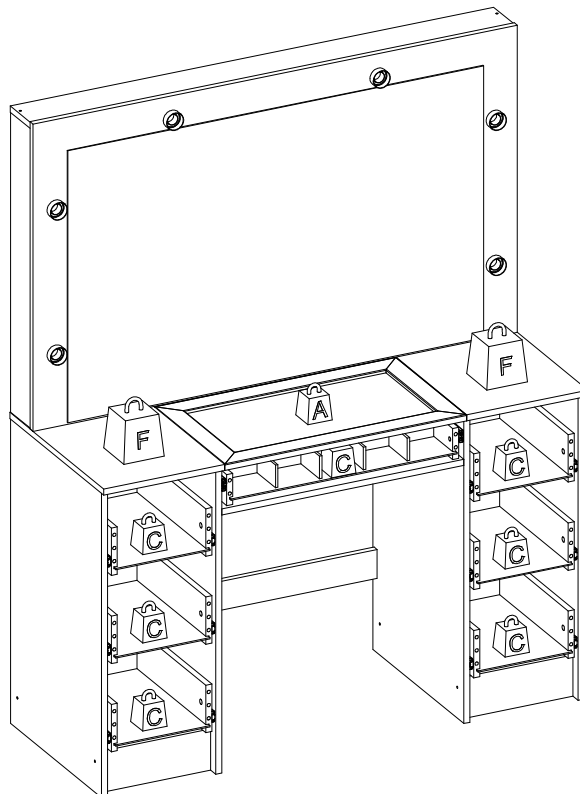

Nº	Measures_Inches	Medidas_cm	Qty./Qtd.
23	22 x 11 3/4 x 1/8	56.0 x 30.0 x 0.3	1
26	47 1/4 x 29 3/8 x 5/8	120.0 x 74.5 x 1.5	1
27	47 1/8 x 3 7/8 x 5/8	119.8 x 10.0 x 1.5	1
28	11 3/4 x 18 1/4 x 5/8	30.0 x 46.5 x 1.5	1
29	11 3/4 x 18 1/4 x 5/8	30.0 x 46.5 x 1.5	1
30	28 5/8 x 3 7/8 x 5/8	72.8 x 10.0 x 1.5	1
31	28 5/8 x 3 7/8 x 5/8	72.8 x 10.0 x 1.5	1
32	29 1/8 x 17 3/4 x 5/8	74.0 x 45.0 x 1.5	1
33	29 1/8 x 17 3/4 x 5/8	74.0 x 45.0 x 1.5	1
34	29 1/8 x 17 3/4 x 5/8	74.0 x 45.0 x 1.5	1
35	29 1/8 x 17 3/4 x 5/8	74.0 x 45.0 x 1.5	1
36	23 5/8 x 3 7/8 x 5/8	60.0 x 10.0 x 1.5	1
37	23 5/8 x 6 1/4 x 5/8	60.0 x 16.0 x 1.5	1
38	23 5/8 x 2 3/4 x 5/8	60.0 x 7.0 x 1.5	1
39	10 1/2 x 3 7/8 x 5/8	26.8 x 10.0 x 1.5	2
40	10 1/2 x 3 1/8 x 5/8	26.8 x 8.0 x 1.5	2
41	23 1/4 x 4 1/2 x 5/8	59.2 x 11.5 x 1.5	1
42	11 3/4 x 3 x 5/8	30.0 x 7.5 x 1.5	1
43	11 3/4 x 3 x 5/8	30.0 x 7.5 x 1.5	1
44	21 1/2 x 3 x 5/8	54.5 x 7.5 x 1.5	1
45	11 5/8 x 8 1/4 x 5/8	29.6 x 20.9 x 1.5	6
46	8 5/8 x 4 1/2 x 5/8	21.9 x 11.5 x 1.5	6
47	13 7/8 x 9 1/8 x 1/8	35.4 x 23.3 x 0.3	6
48	26 3/4 x 11 3/8 x 1/8	67.8 x 28.8 x 0.3	2
49	23 5/8 x 13 3/4 x 1/8	60.0 x 35.0 x 1.5	1
96	14 x 4 1/2 x 5/8	35.5 x 11.5 x 1.5	6
97	14 x 4 1/2 x 5/8	35.5 x 11.5 x 1.5	6

PARTS IDENTIFICATION IDENTIFICAÇÃO DAS PEÇAS / IDENTIFICACIÓN DE LAS PIEZAS

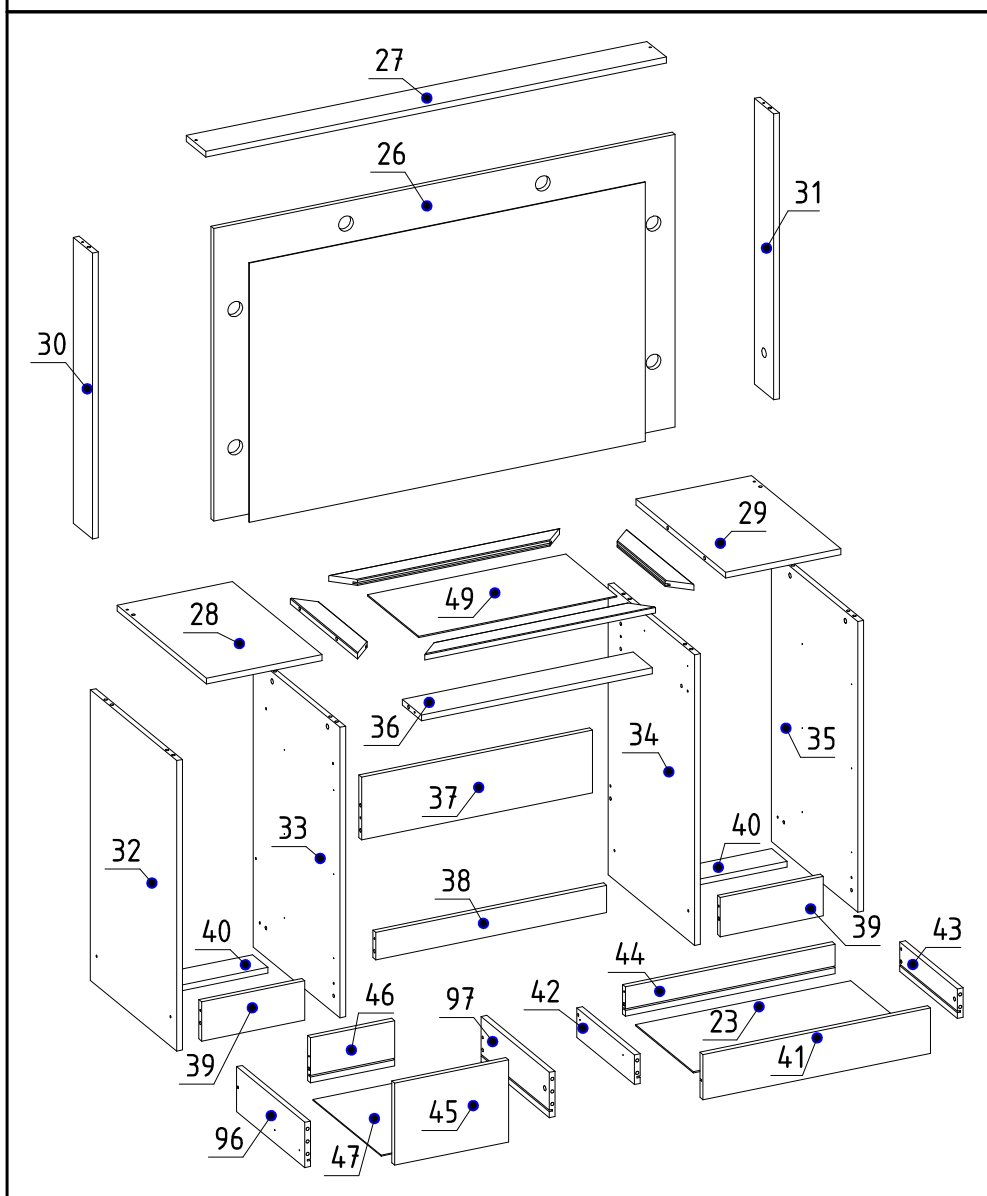

YOU WILL NEED / VOCÊ VAI PRECISAR DE / USTED NECESITARÁ

Tools not supplied / Ferramentas não fornecidas / Herramientas no incluidas

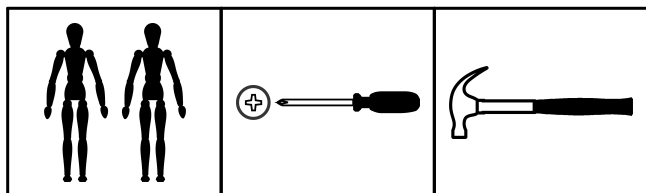

2 People
2 Pessoas
2 Personas

Screwdriver Phillips
Chave Phillips
Destornillador cruz

Hammer
Martelo
Martillo













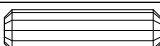



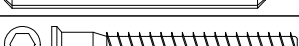

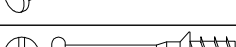

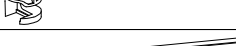

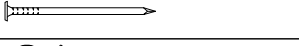
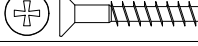
The separation of the accessories before you start the assembly will facilitate the same. In case of doubt on the size of the screws and bolts, use the ruler to bottom of page 3.

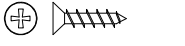
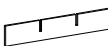
A separação dos acessórios antes de iniciar a montagem facilitará a mesma. Em caso de dúvida no tamanho dos parafusos e cavilhas, utilize a régua ao final da página 3.

La separación de los accesorios antes de comenzar el armado facilitará el mismo. En caso de duda sobre el tamaño de los tornillos y taquetes, utilice la regla al pie de página 3.

IDENTIFICATION OF ACCESSORIES IDENTIFICAÇÃO DOS ACESSÓRIOS/ IDENTIFICACIÓN DE ACCESORIOS

A1		Glue / Cola / Pegamento	13 g	1
A3		Trapeze / Trapézio / Trapecio	-	2
B5		Metalic angle plates / Cantoneira de metal / Suporte de metal	46 mm	7
E		Wooden dowel / Cavilha / Taquete	8x30 mm	70
E4		Mirror support / Suporte espelho / Suporte espejo	-	4
E5		Socket/ Soquete bipolar/ Enchufe	-	6
E7		Smal plastic foot / Sapata / Pie plástico	15 mm	8
F		Wooden dowel / Cavilha / Taquete	8x50 mm	2
G		Structural screw / Parafuso estrutural / Tornillo estructural	5,0x50 mm	18
H		Allen key / Chave allen / Liave allen	3 mm	1
I		Structural screw cover/Tampa parafuso estrutural/Tapa tornillo estructural	-	10
J		Simple minifix screw / Haste minifix simples / Tornillo minifix simple	-	20
L		Drum lock / Tambor minifix / Tambor minifix	12 mm	20
L17		Telescopic slide / Corrediça telescópica / Corredera telescópica	350 mm	12
M		Bore patch adhesive / Tapa furo adesivo / Tapones adhesivo	-	12
N		Nail / Prego / Clavo	10x10	44
O		Flat head screw / Parafuso chato / Tornillo de cabeza plana	4,5x45 mm	14
P		Pan head screw / Parafuso panela / Tornillo de pan	4,5x25 mm	2
P5		Flat head screw / Parafuso chato especial / Tornillo de cabeza plana	3,5x14 mm	60
Q14A		Drawer divider / Divisor de gavetas / Divisor de cajón	544mm	2
Q14B		Drawer divider / Divisor de gavetas / Divisor de cajón	284mm	4
S		Pan head screw / Parafuso panela / Tornillo de pan	3,5x14 mm	40
S2		Handle / Puxador metálico / Tirador	-	6
S10		Telescopic slide / Corrediça telescópica / Corredera telescópica	300 mm	2
Y3A		Electric cable part 1 / Chicote elétrico parte 1 / Cable eléctrico parte 1	-	1
Y3B		Switch / Interruptor / Interruptor	-	1
Y3C		Electric cable part 2 / Chicote elétrico parte 2 / Cable eléctrico parte 2	-	1



PRE-ASSEMBLE
PRÉ-MONTAGEM / PRE ARMADO

01

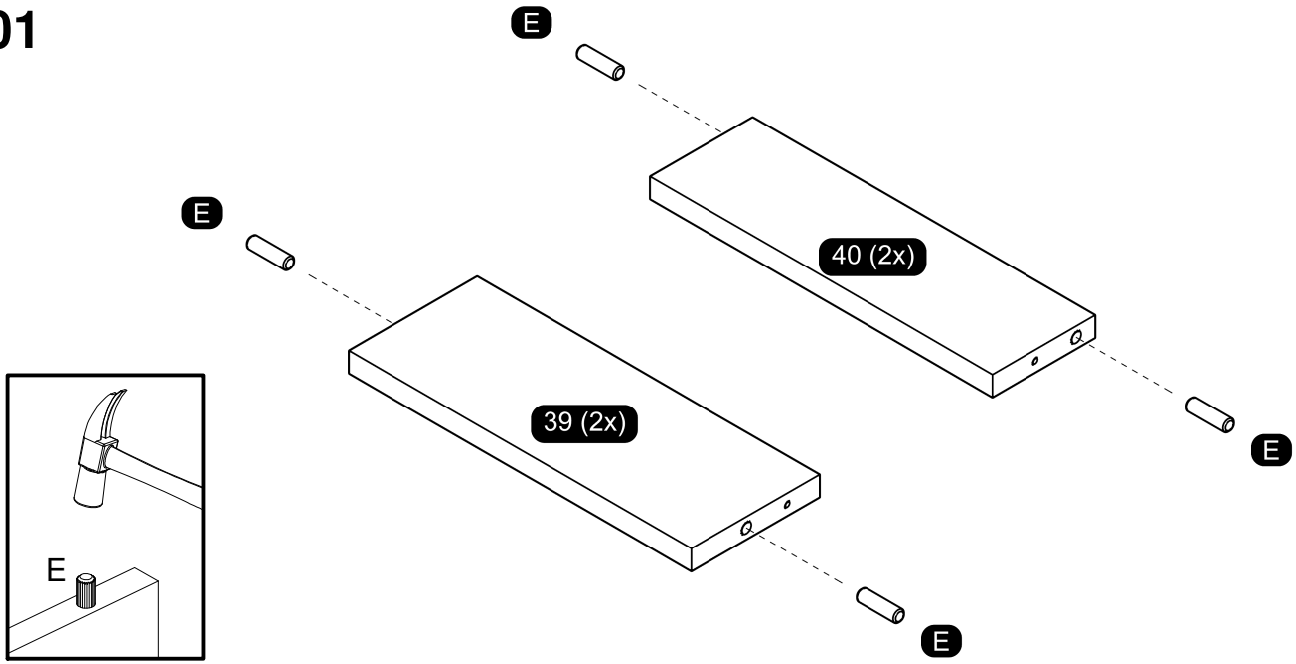

02

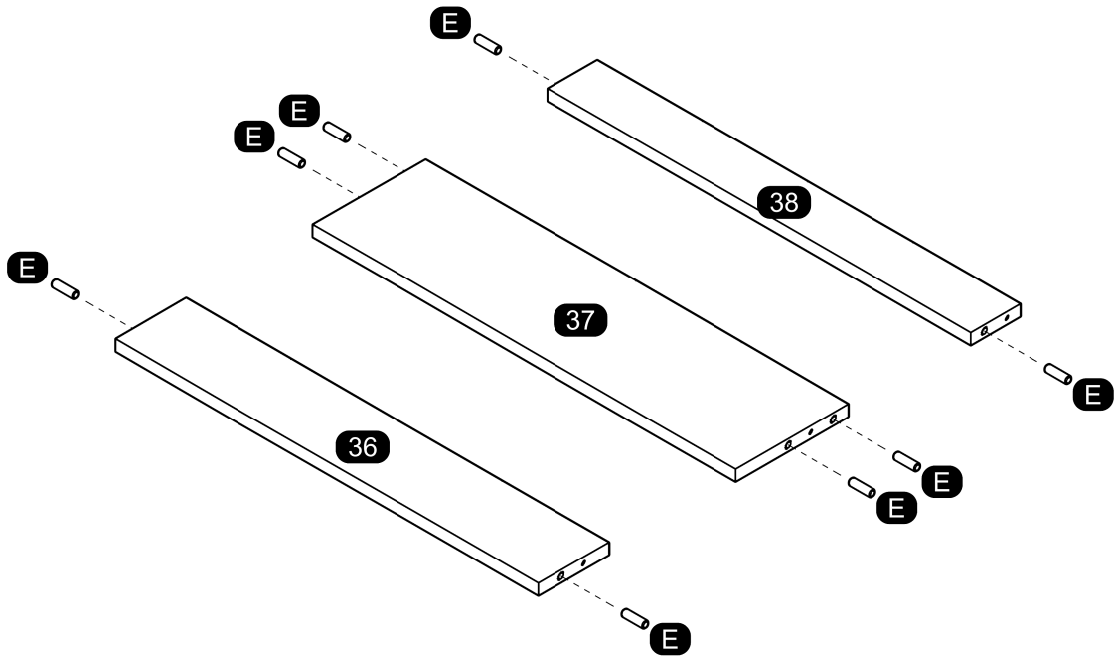

03

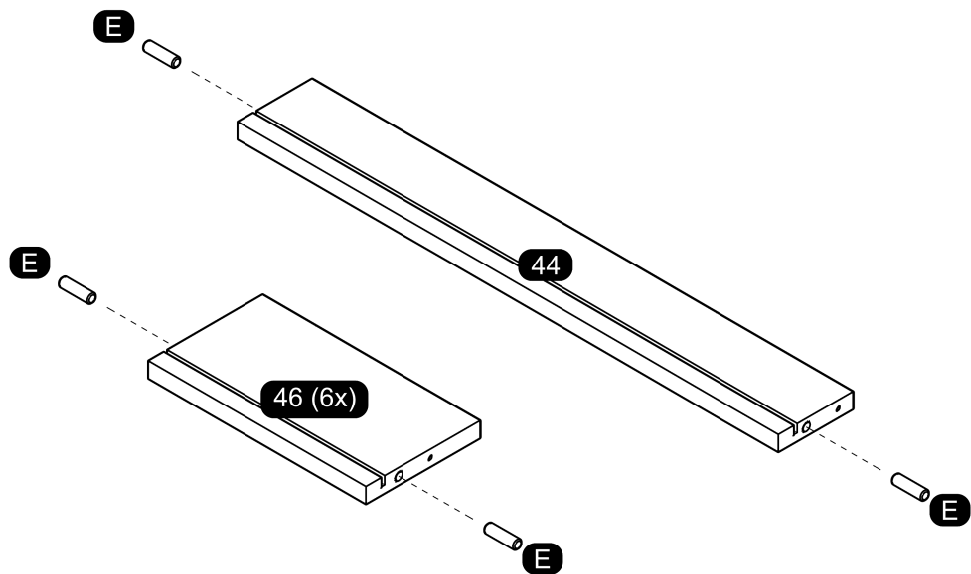

04

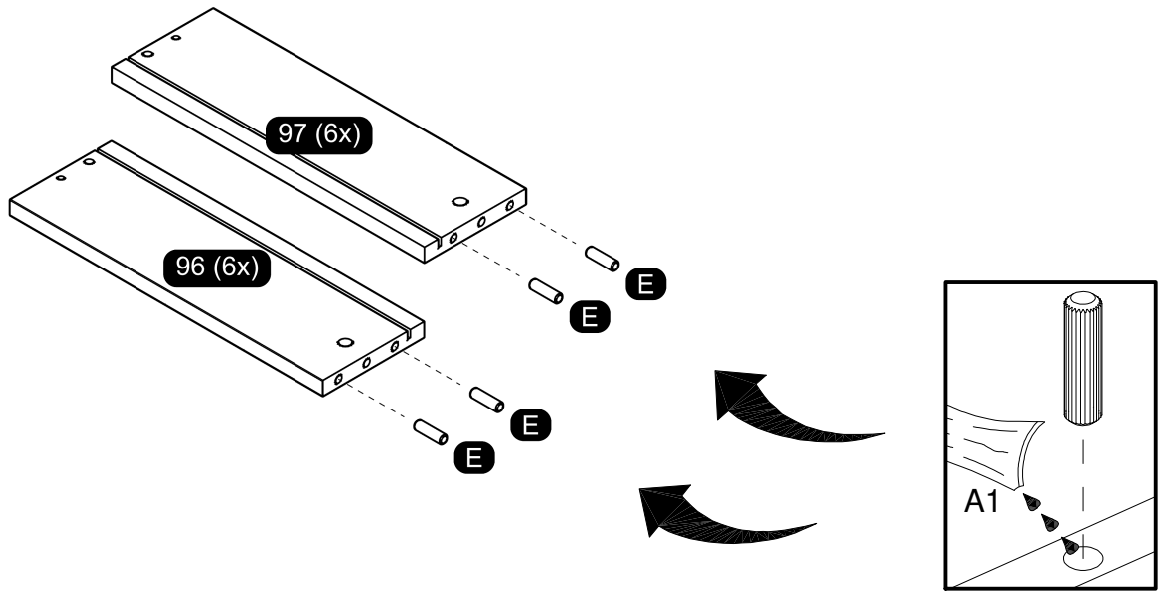

05

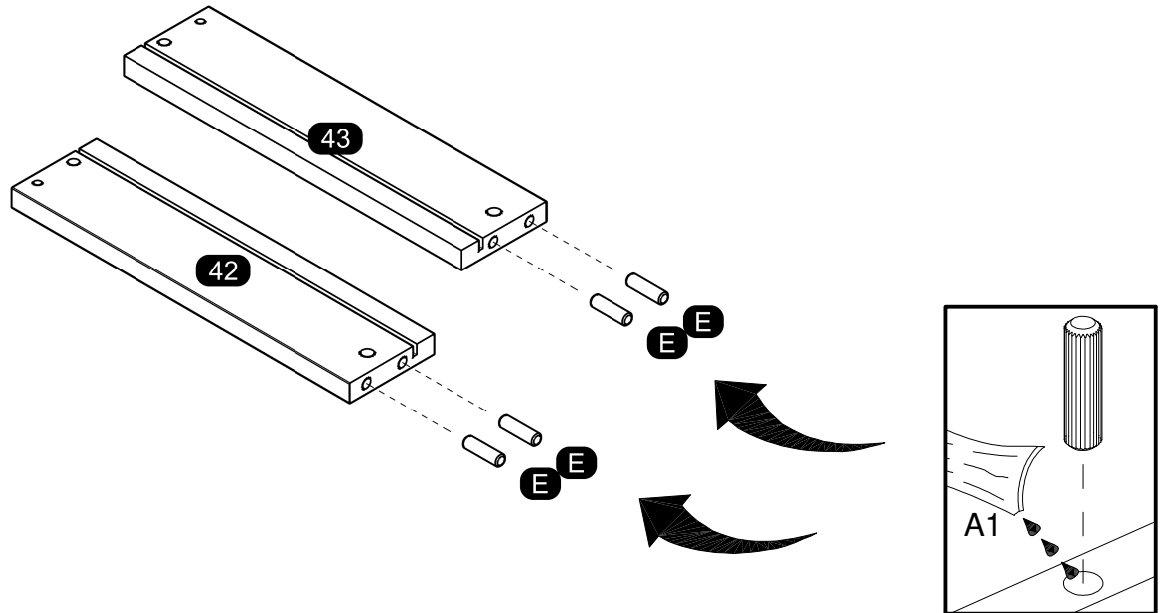

06

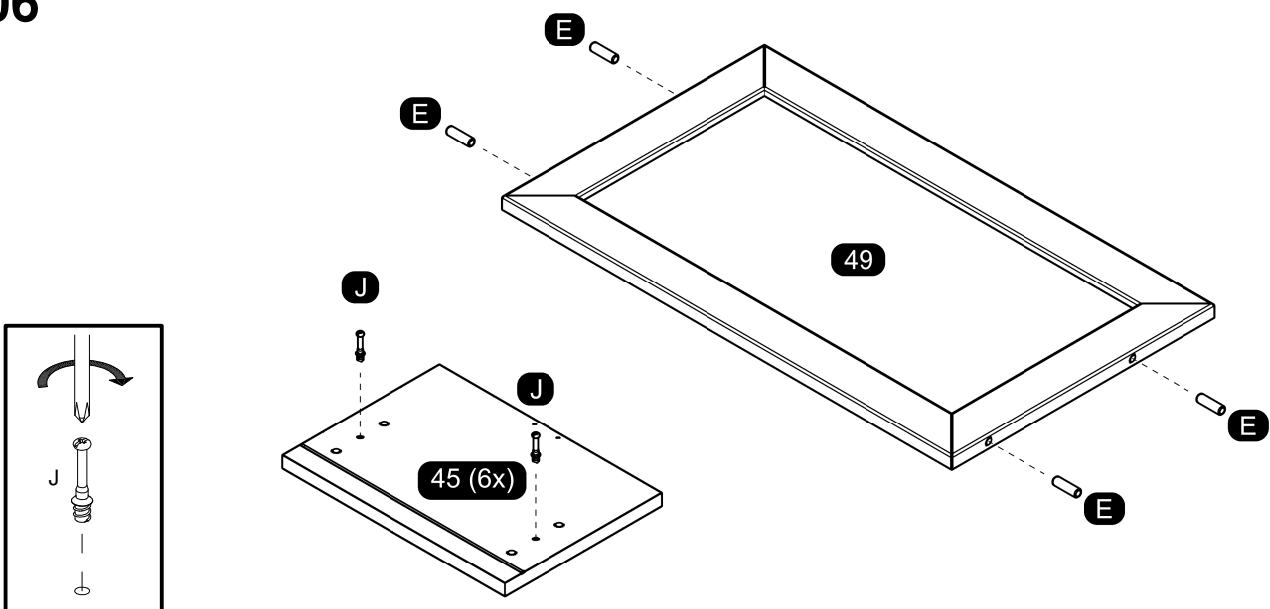

07

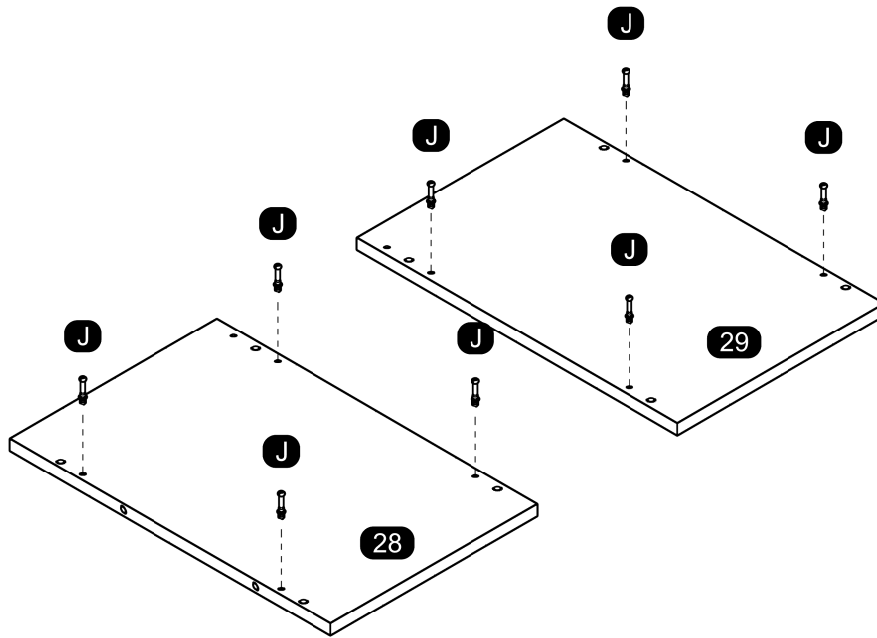

08

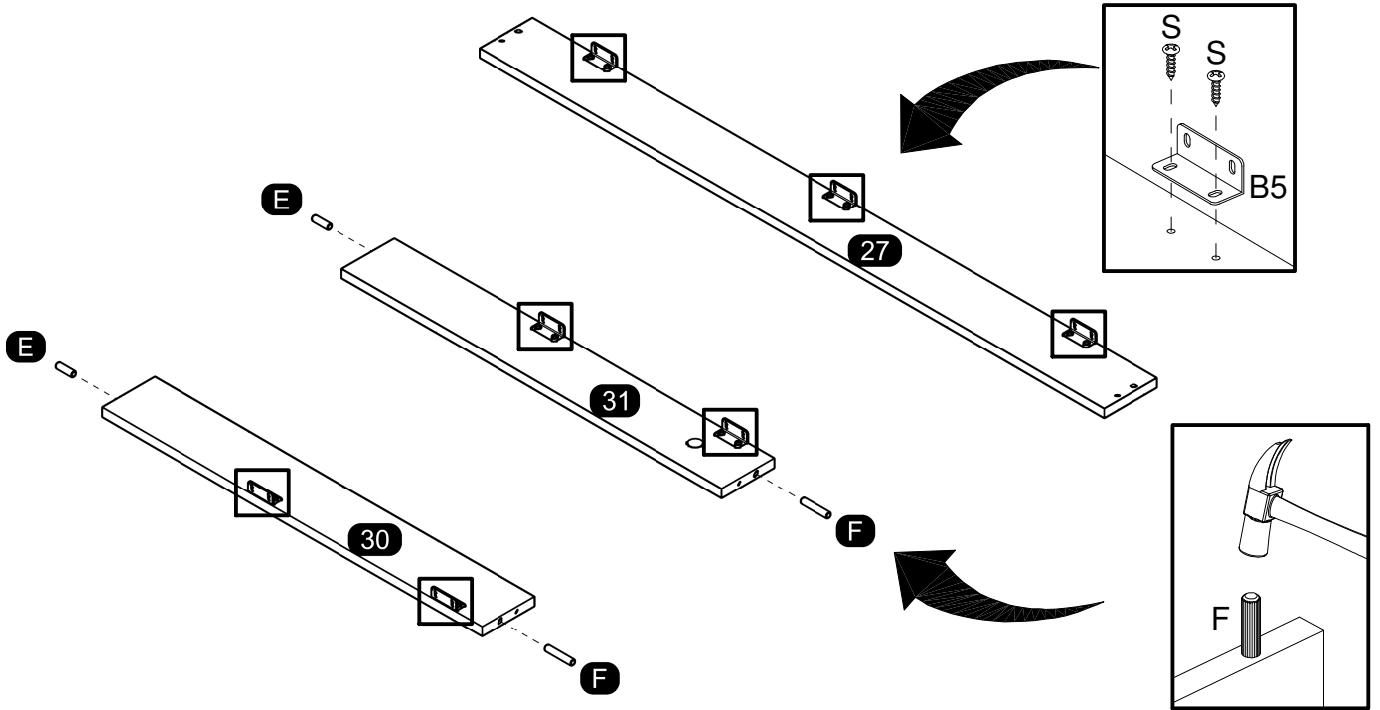

09

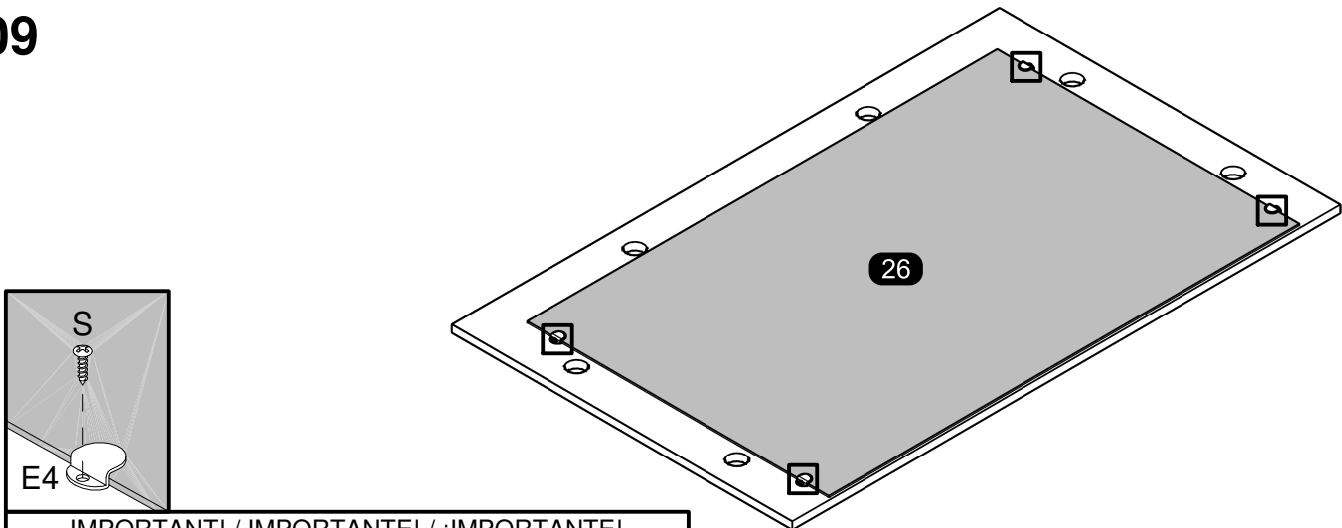

IMPORTANT! / IMPORTANTE! / ¡IMPORTANTE!
 It's essential to fixing the accessory "E4" for safety.
 É imprescindível a fixação do acessório "E4" por segurança.
 Es esencial fijar el accesorio "E4" para la seguridad.

10

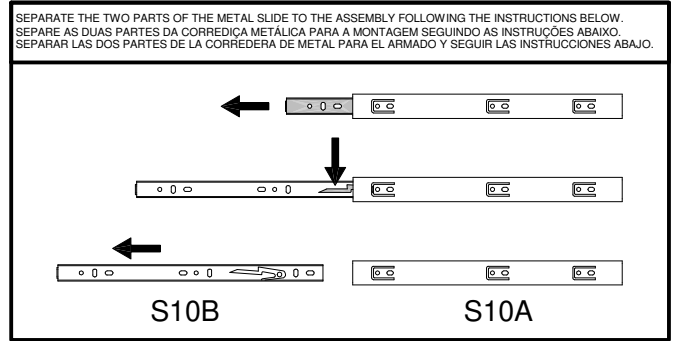
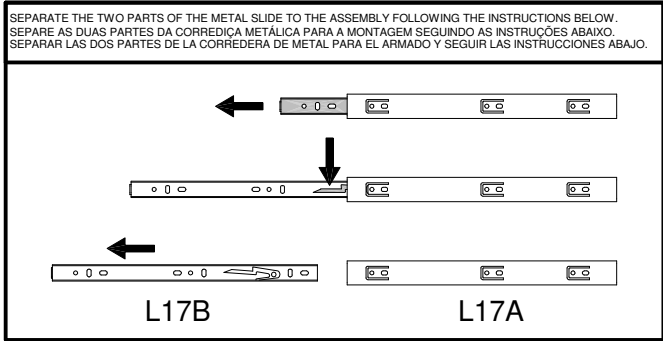

11

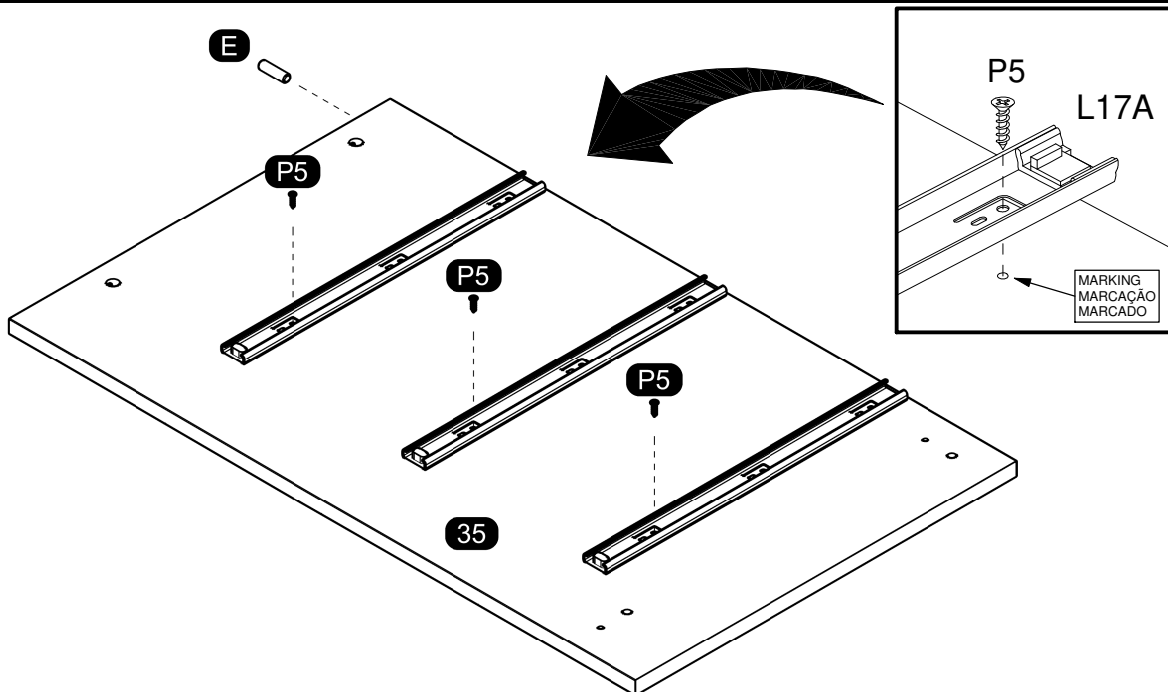

12

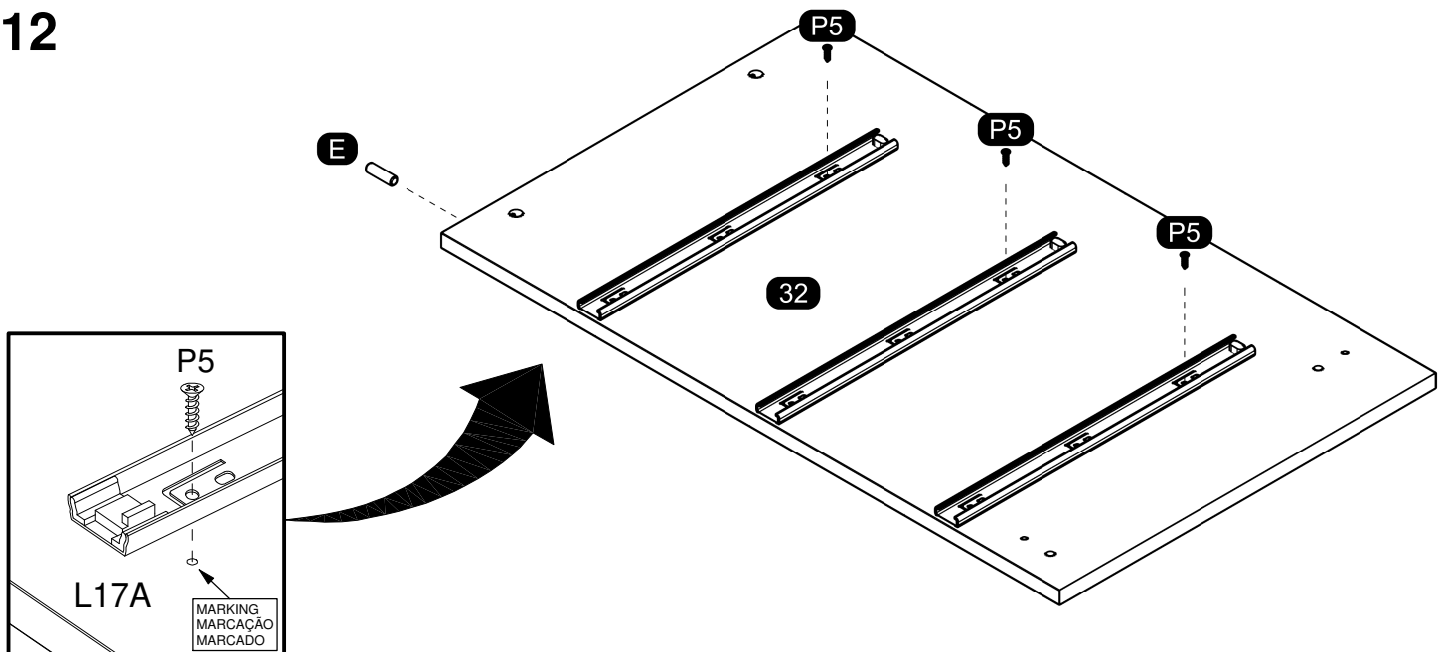

13

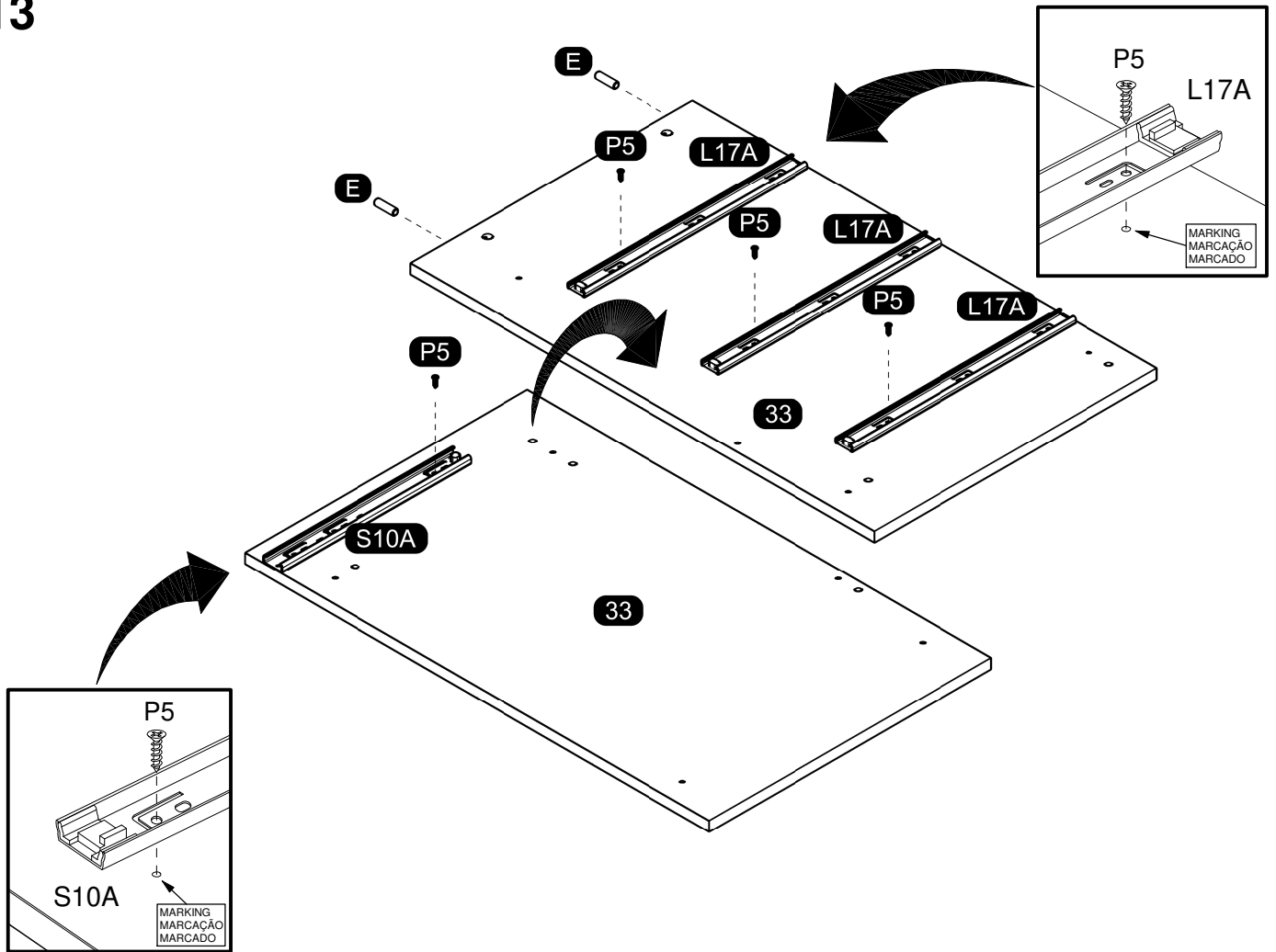

14

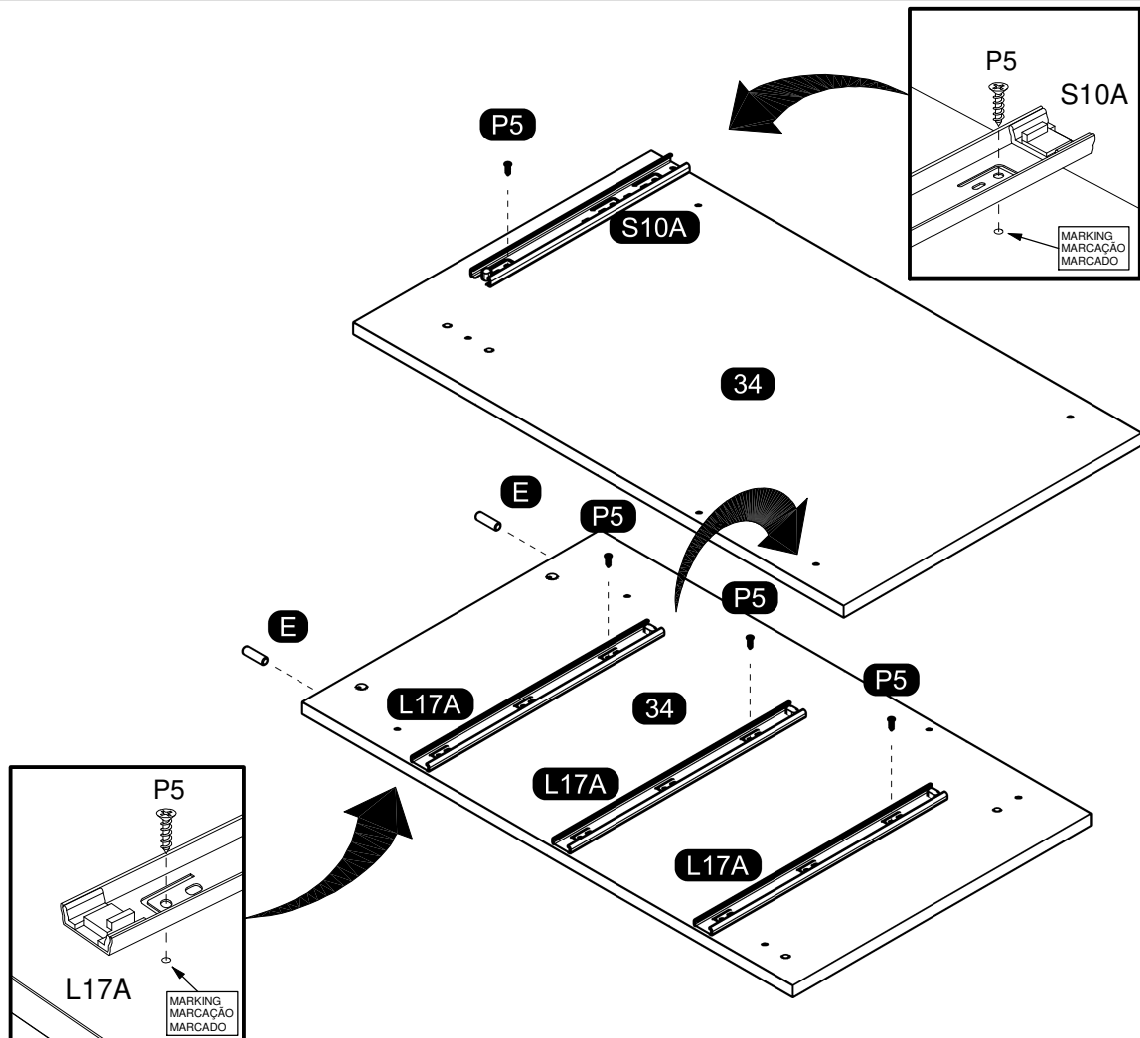

ASSEMBLY
MONTAGEM / ARMADO

15

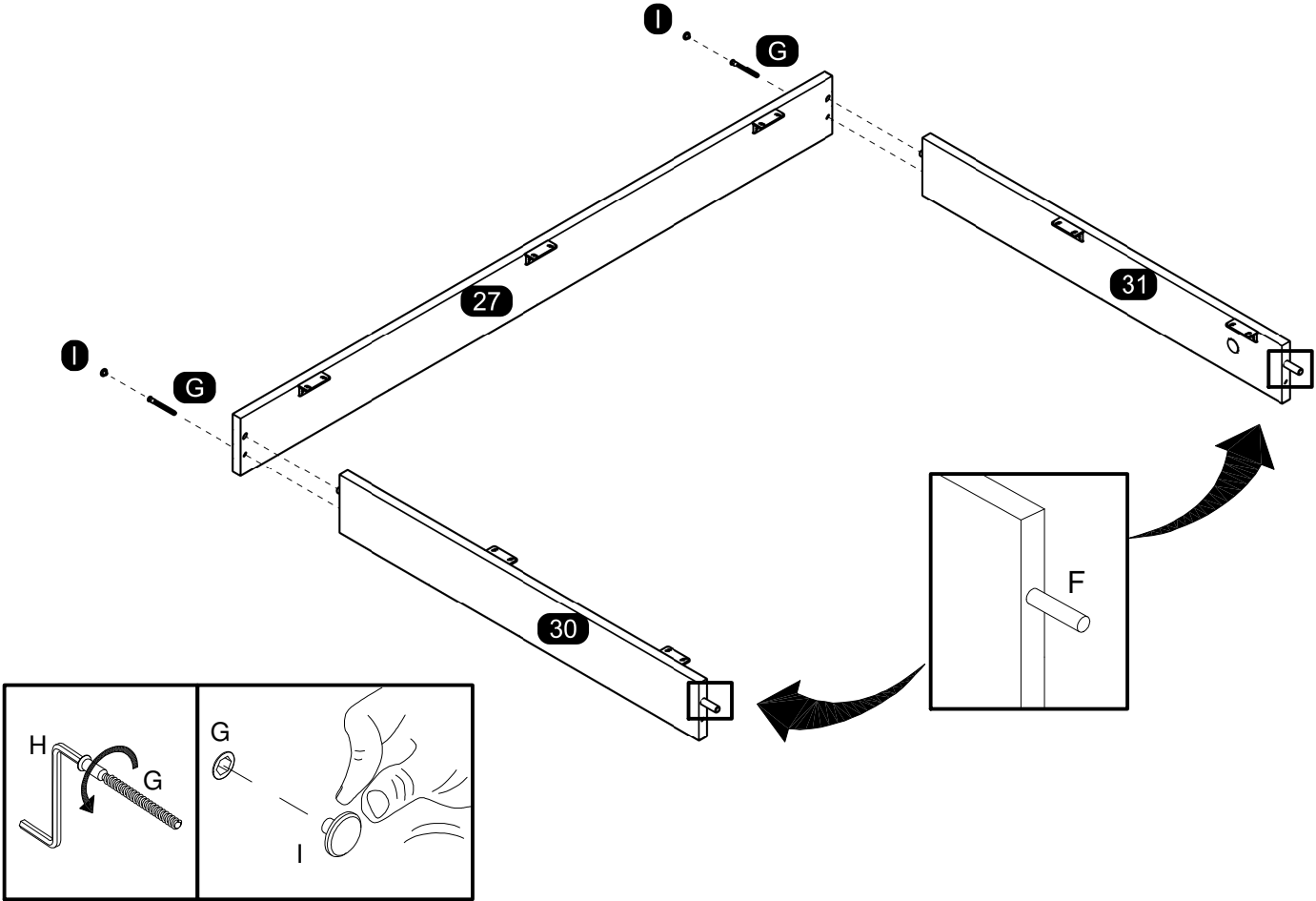

16

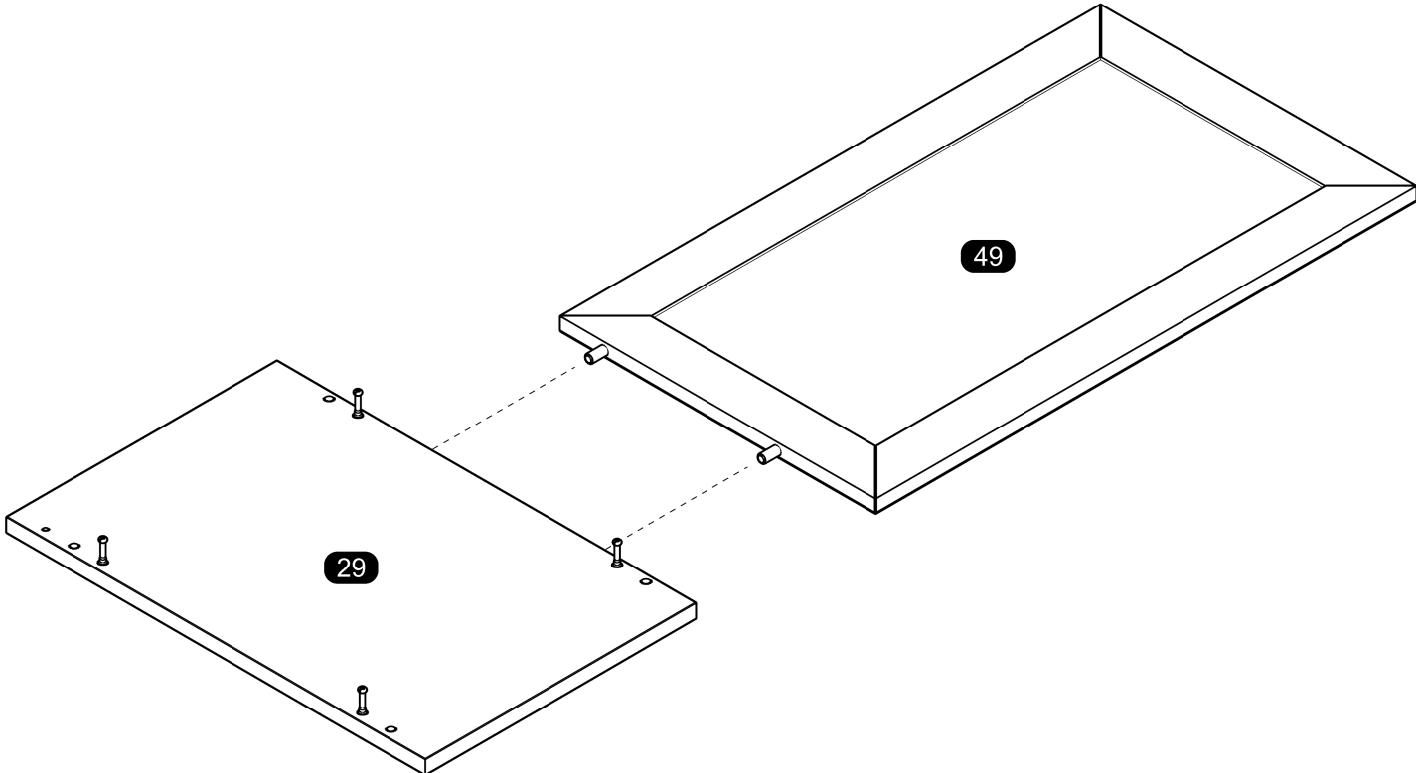

17

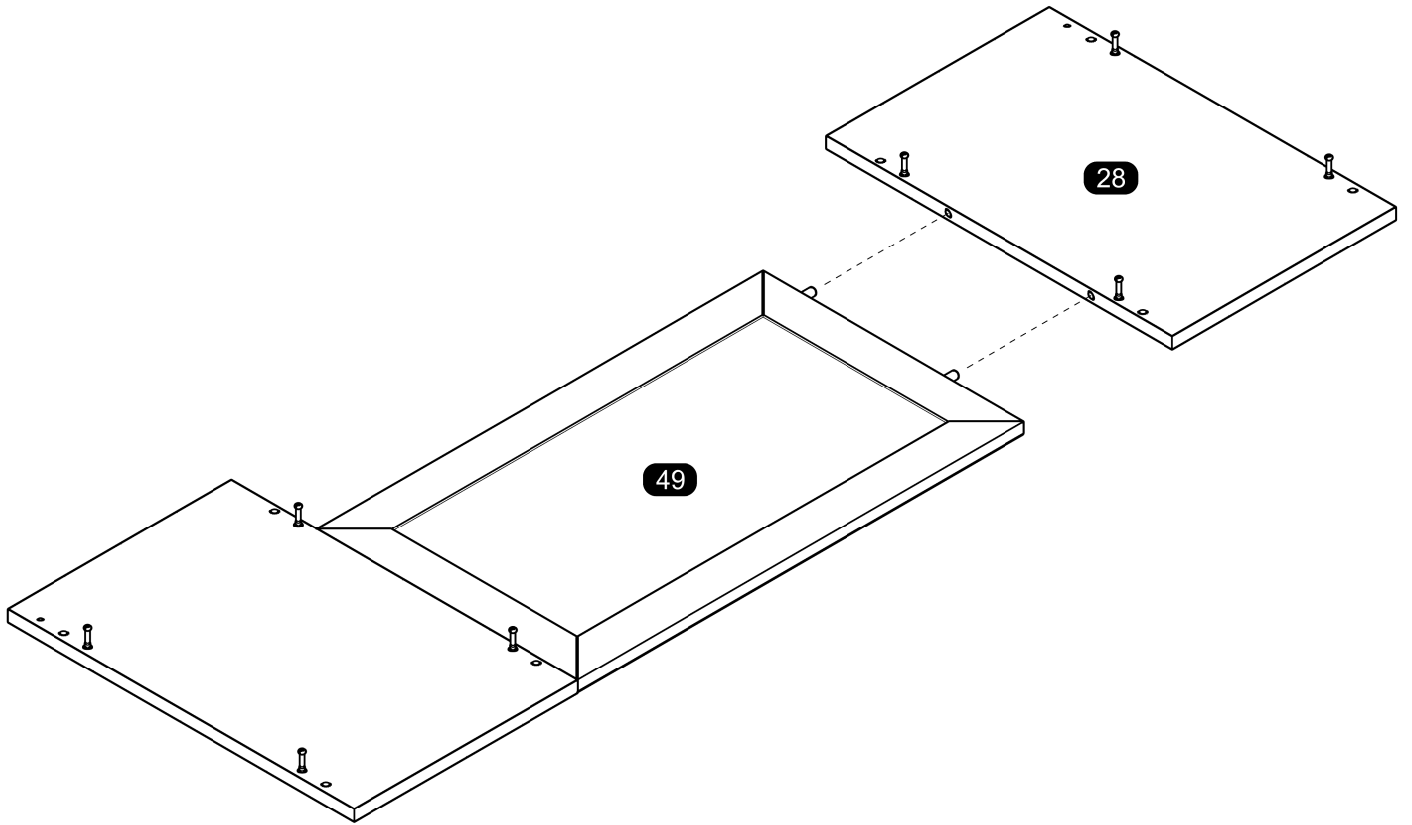

18

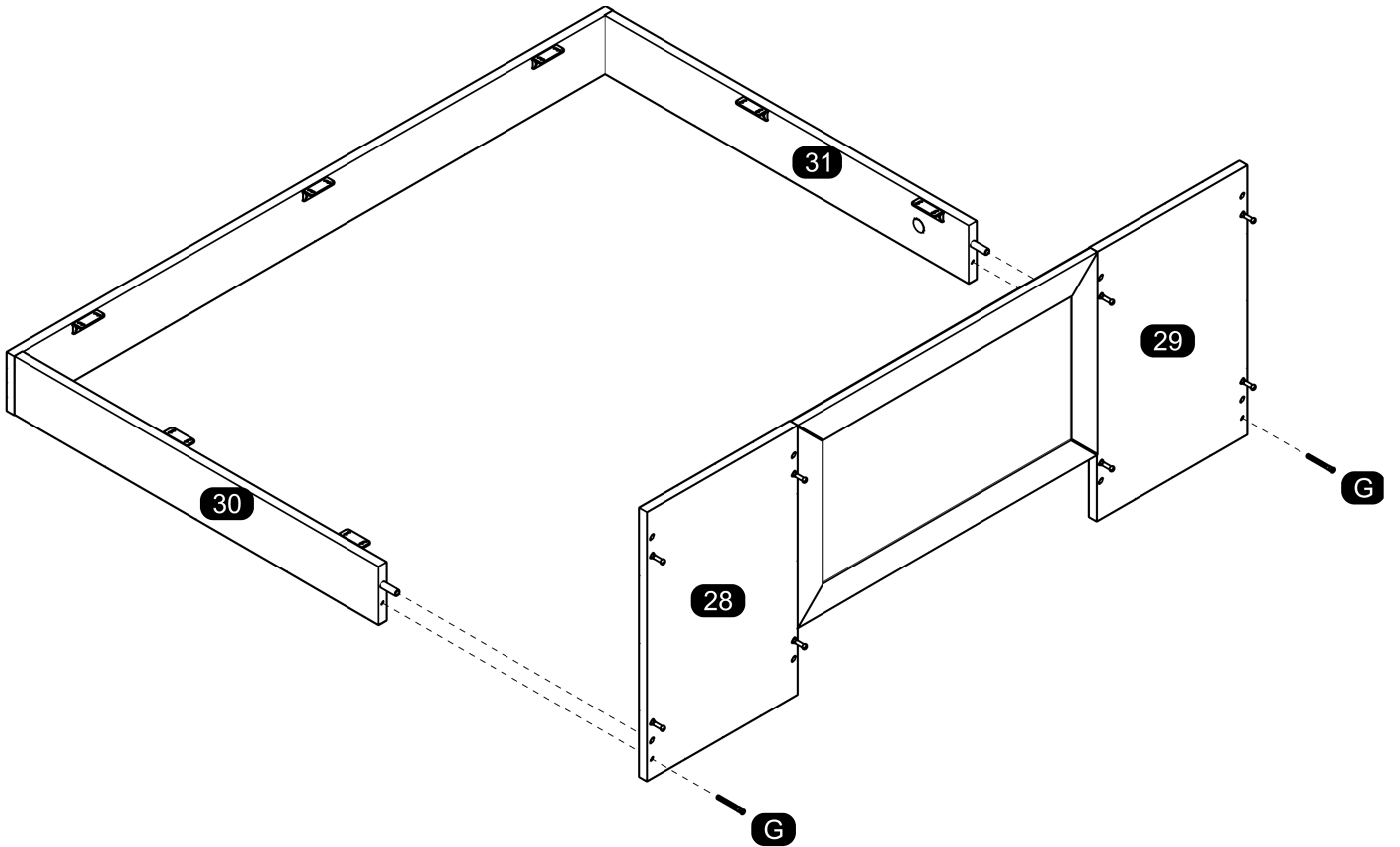

19

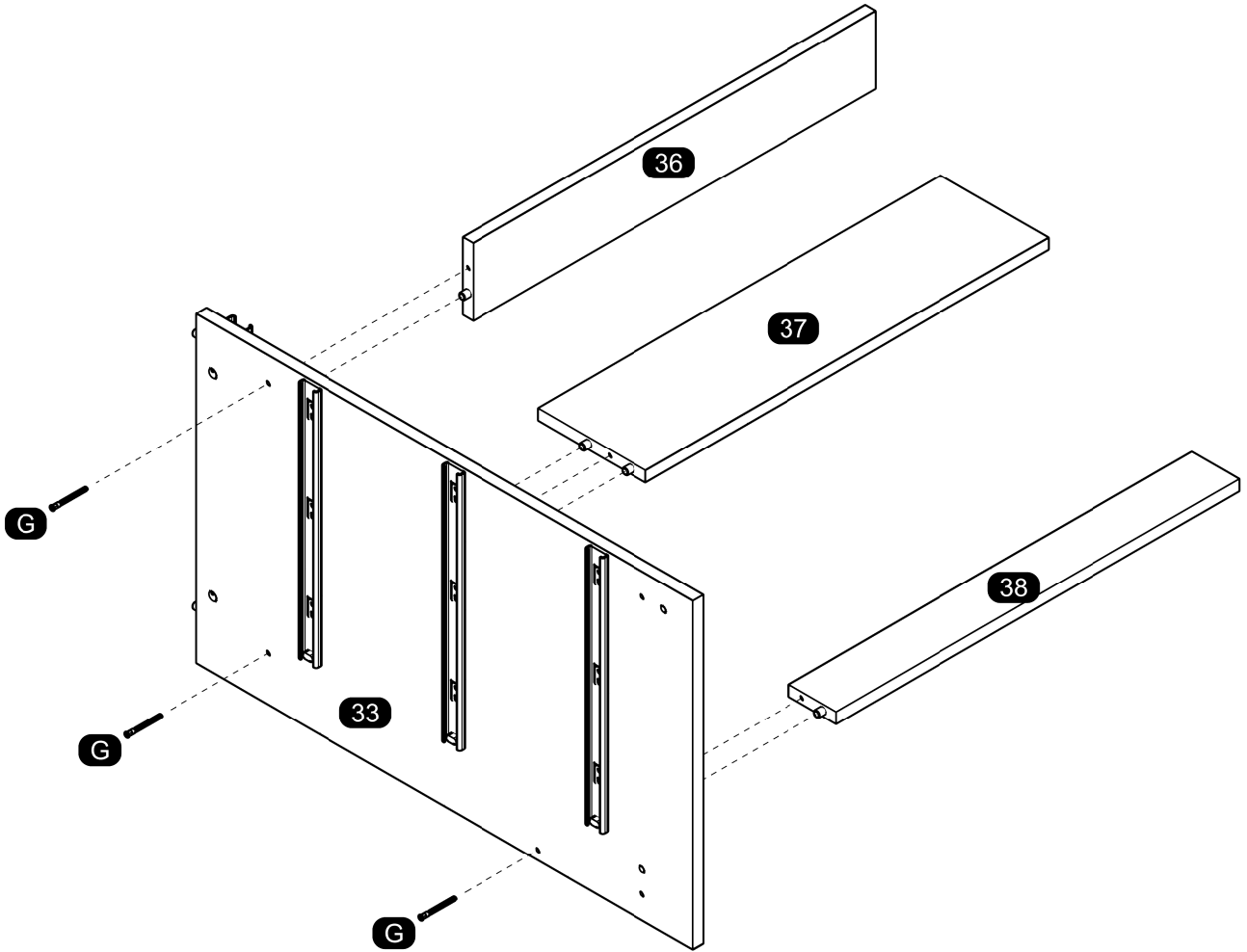

20

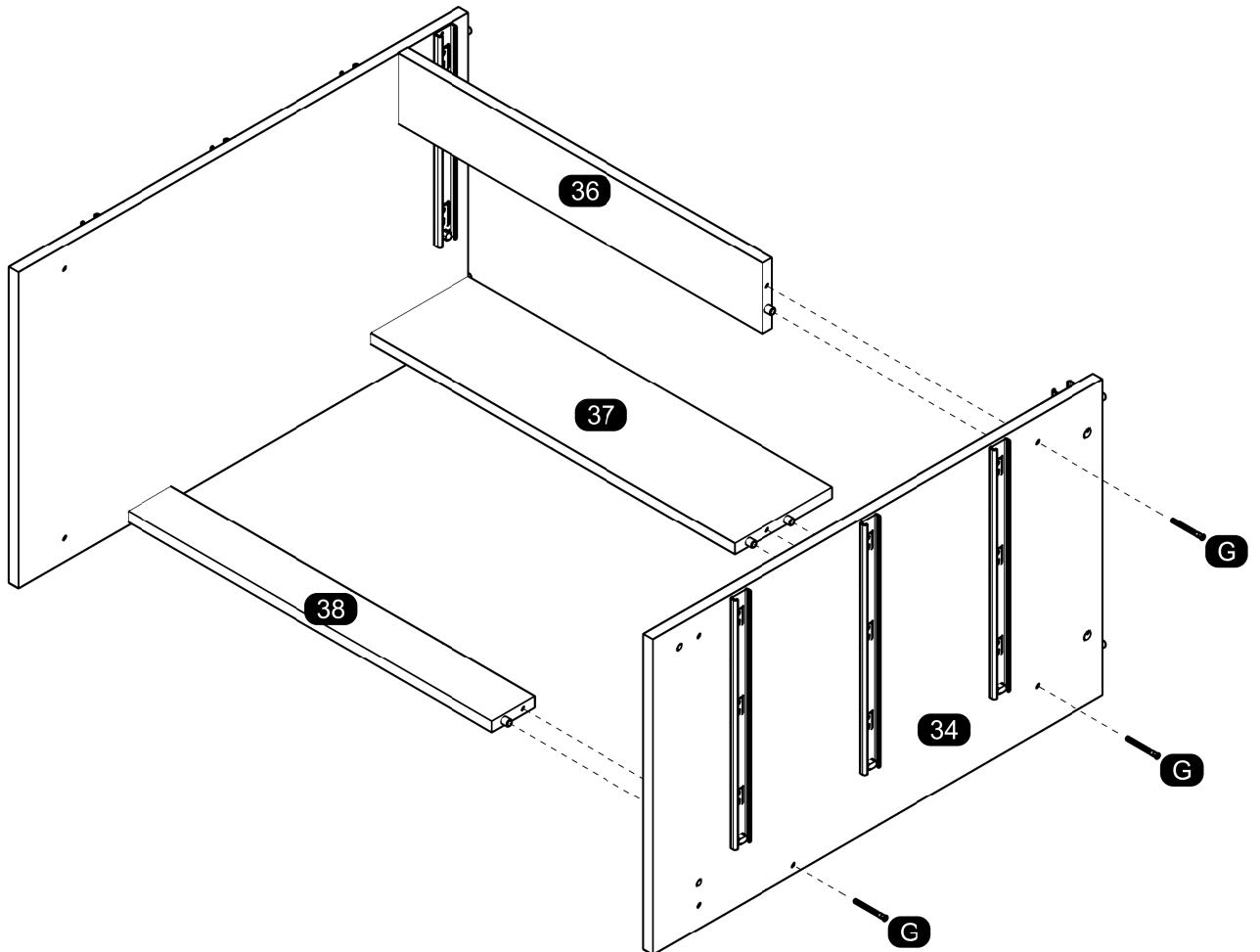

21

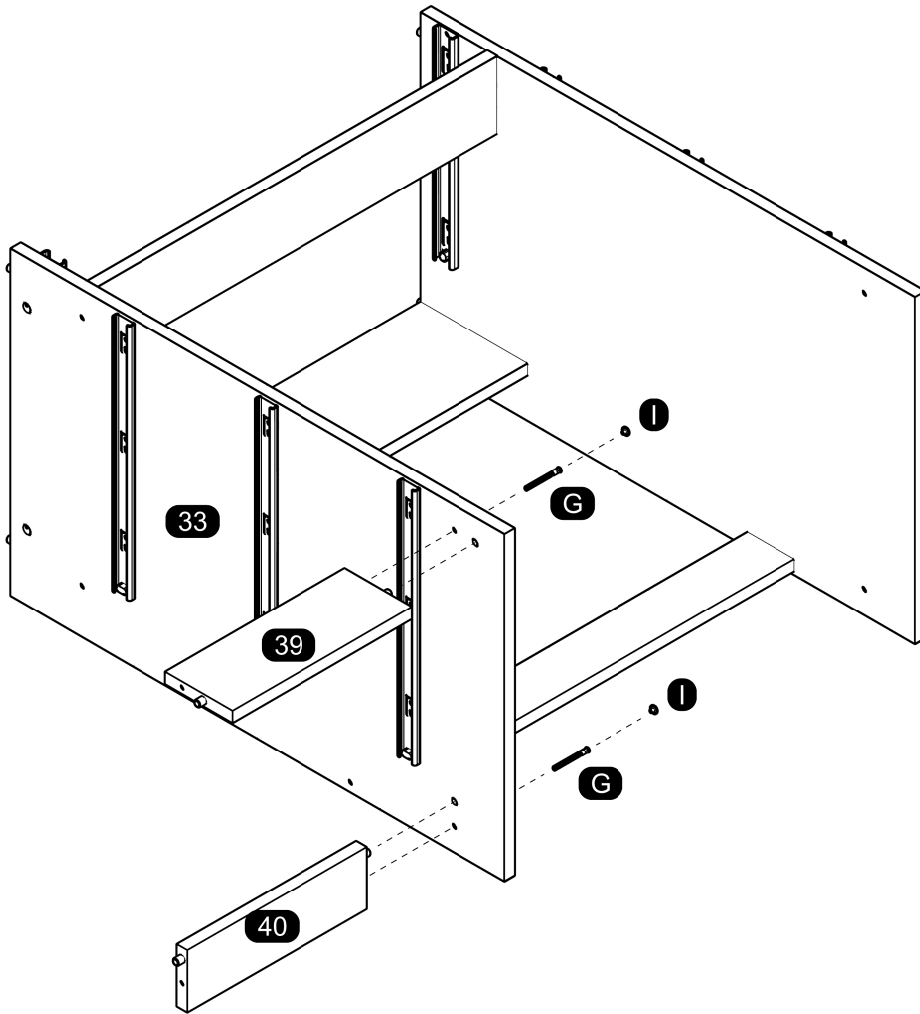

22

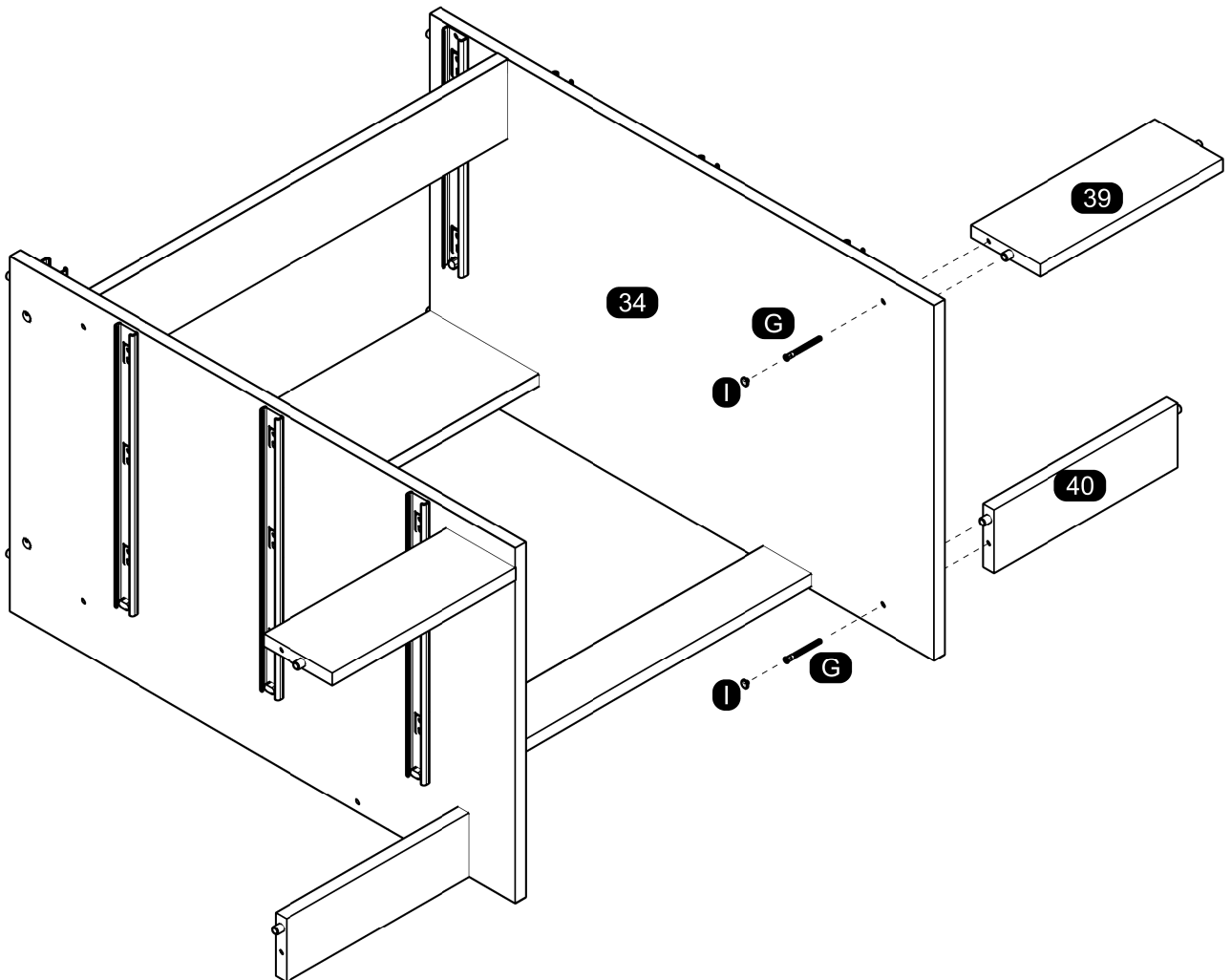

23

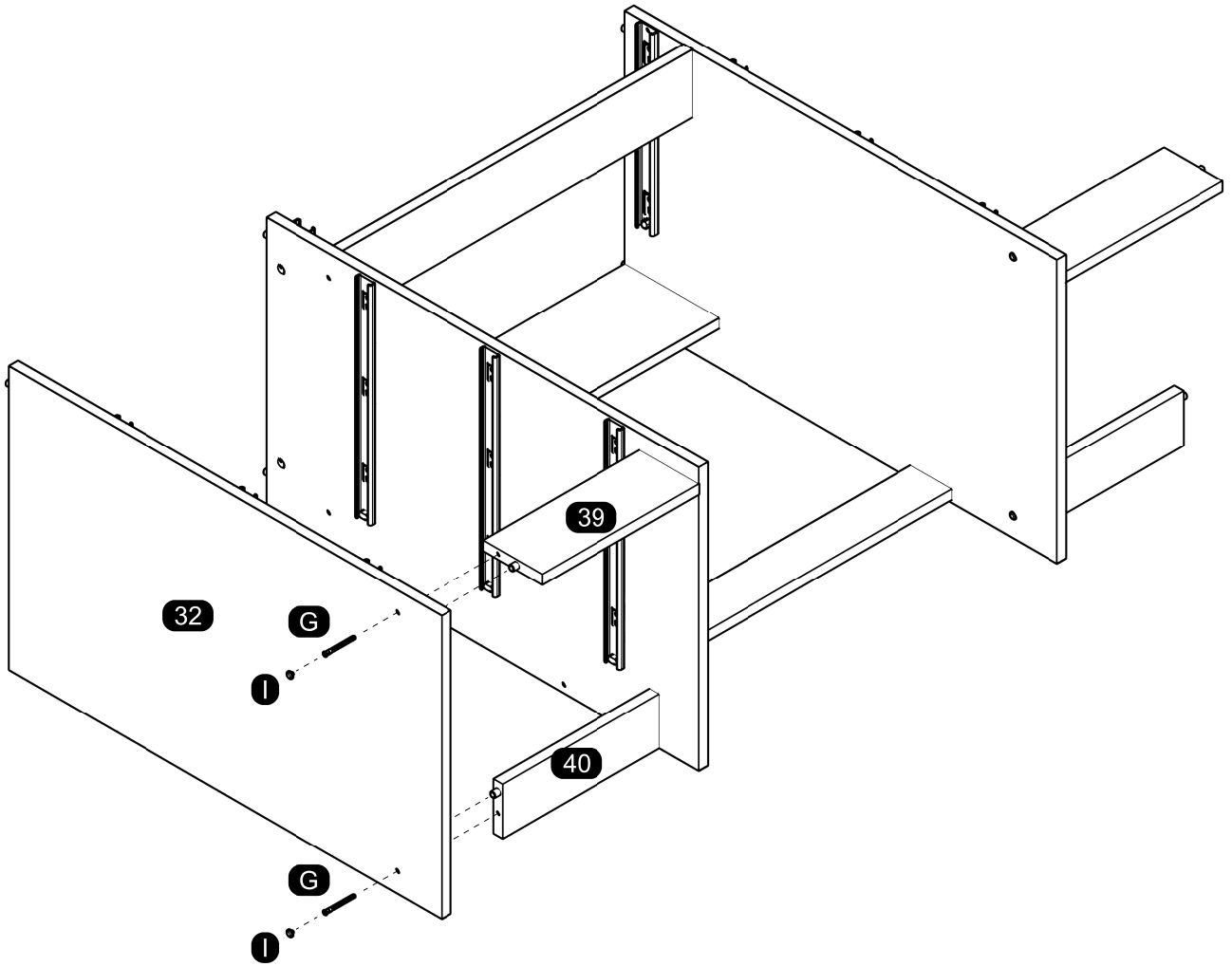

24

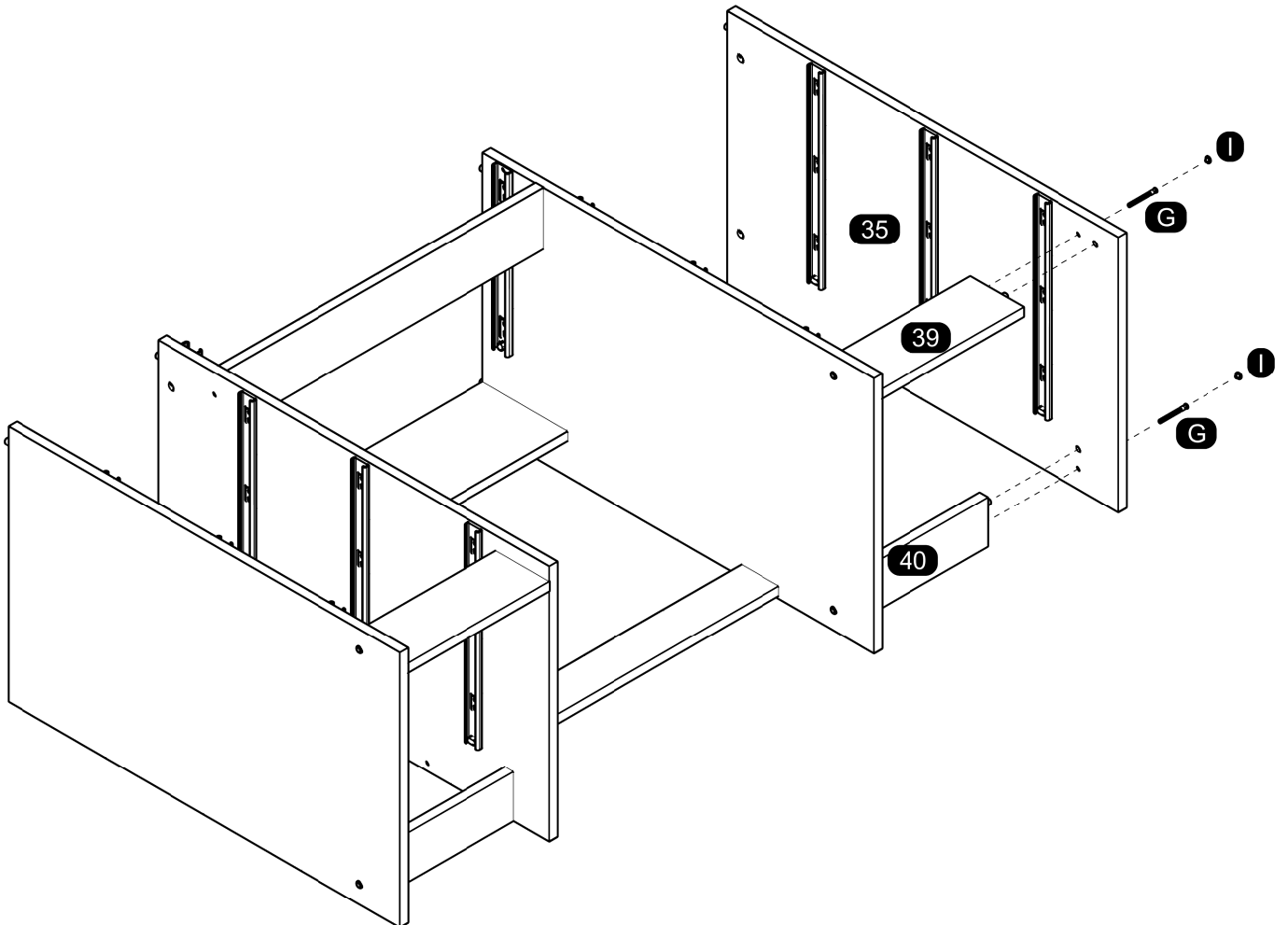

25

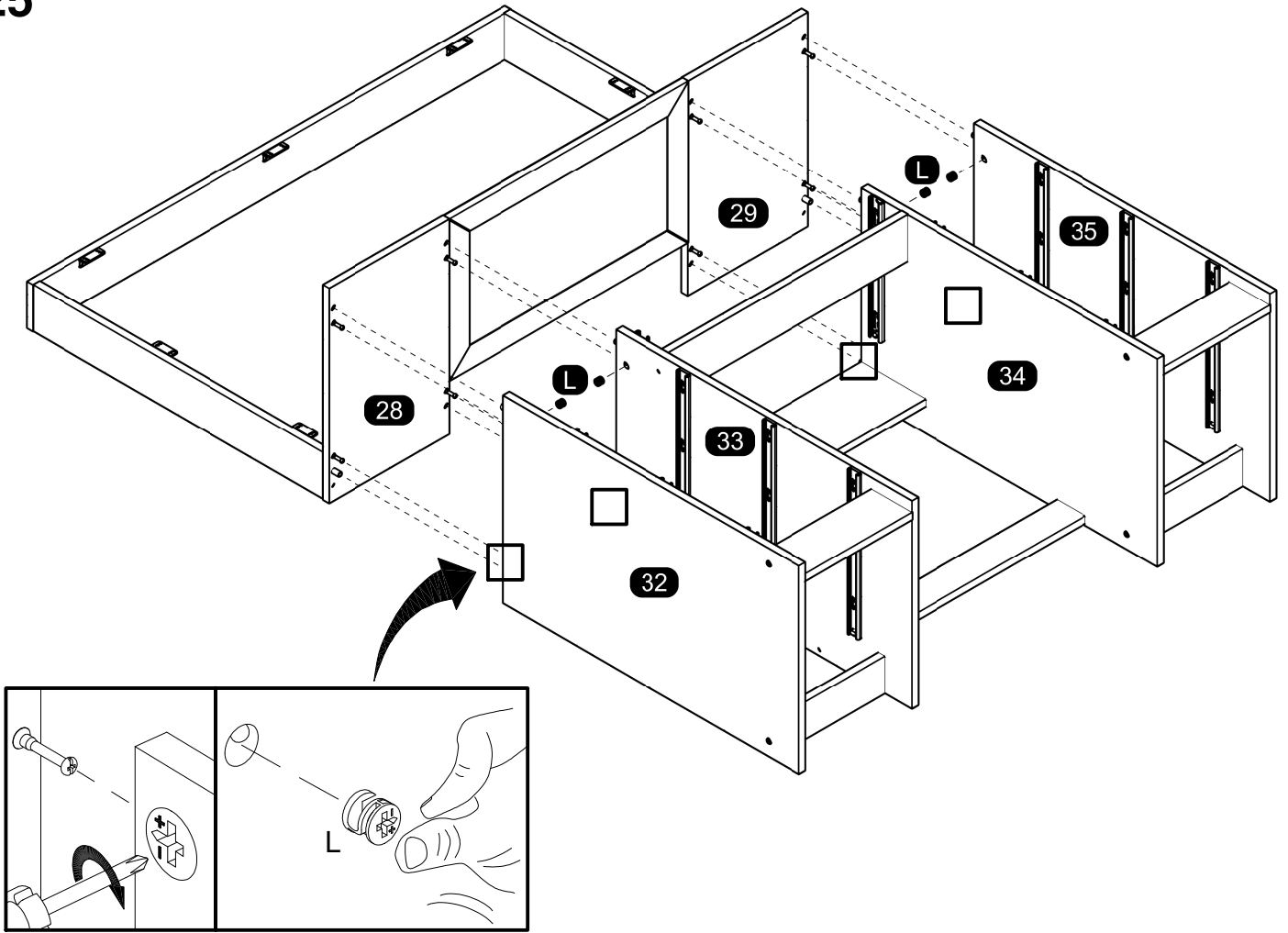

26

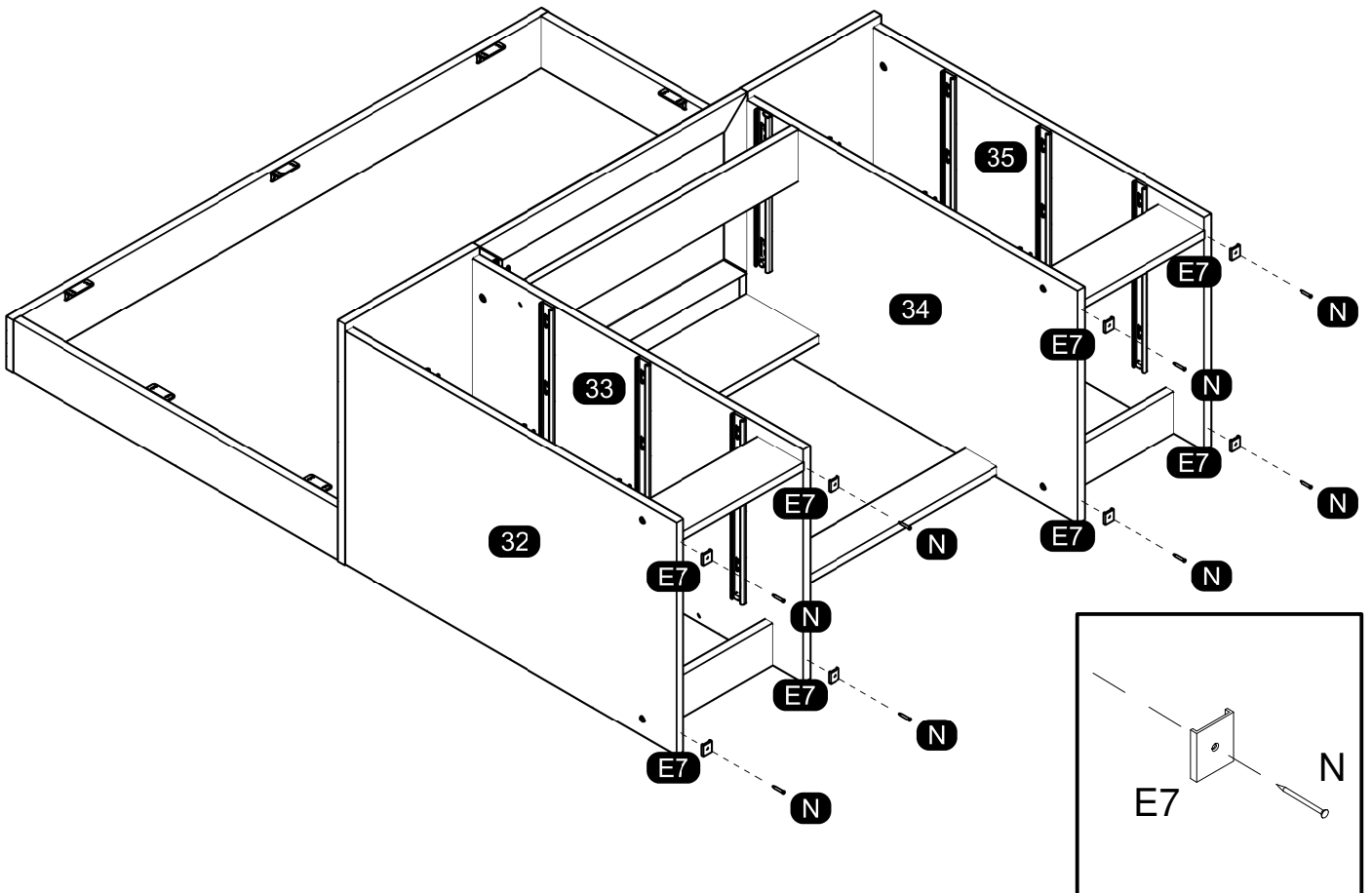

27

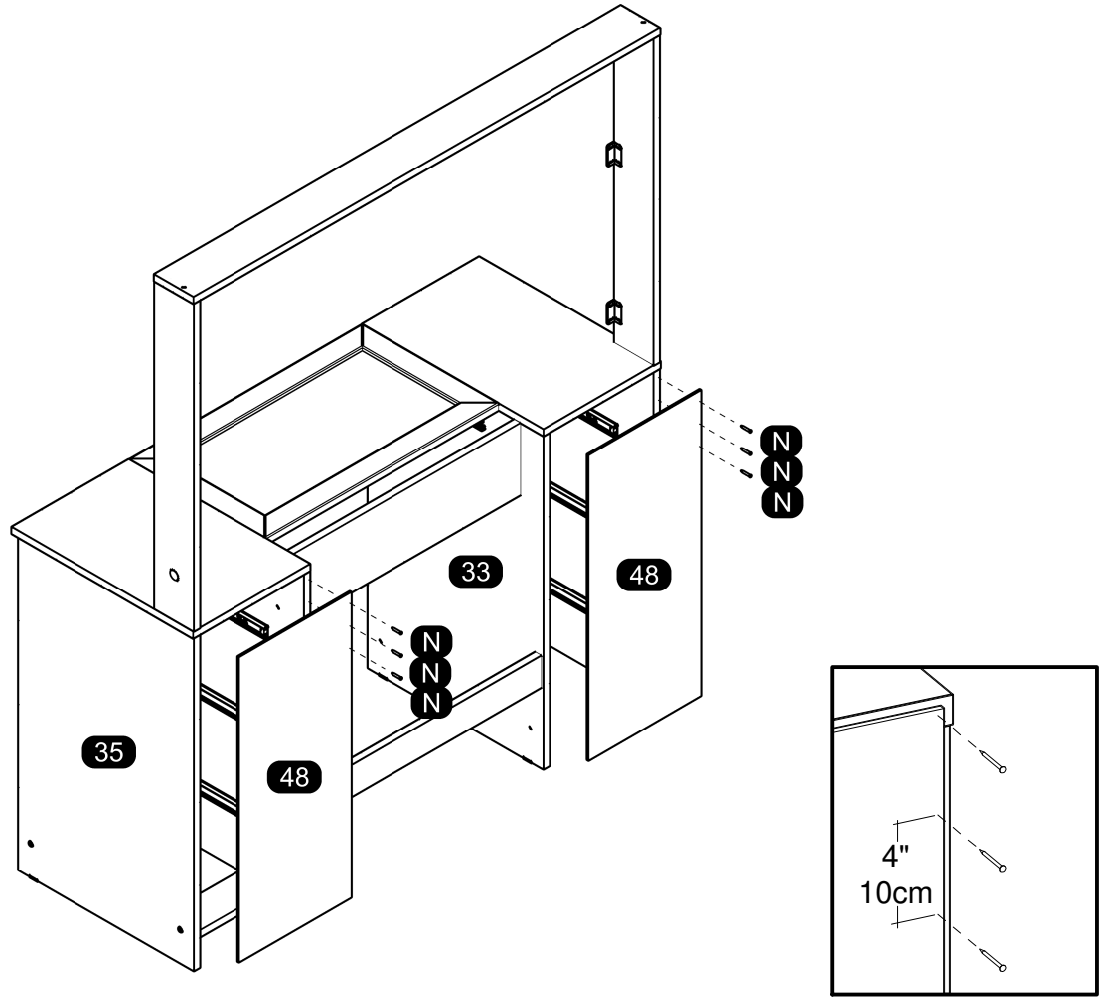

28

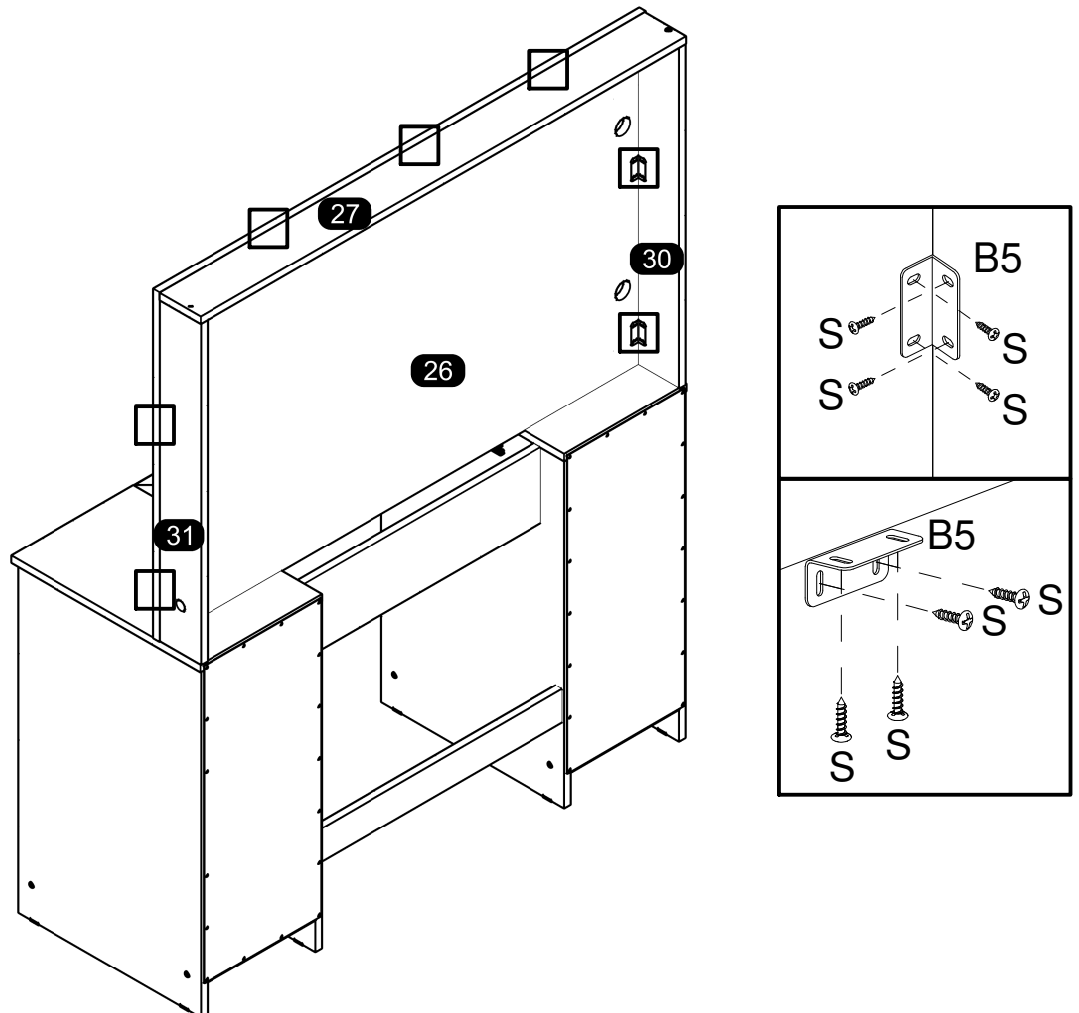

29

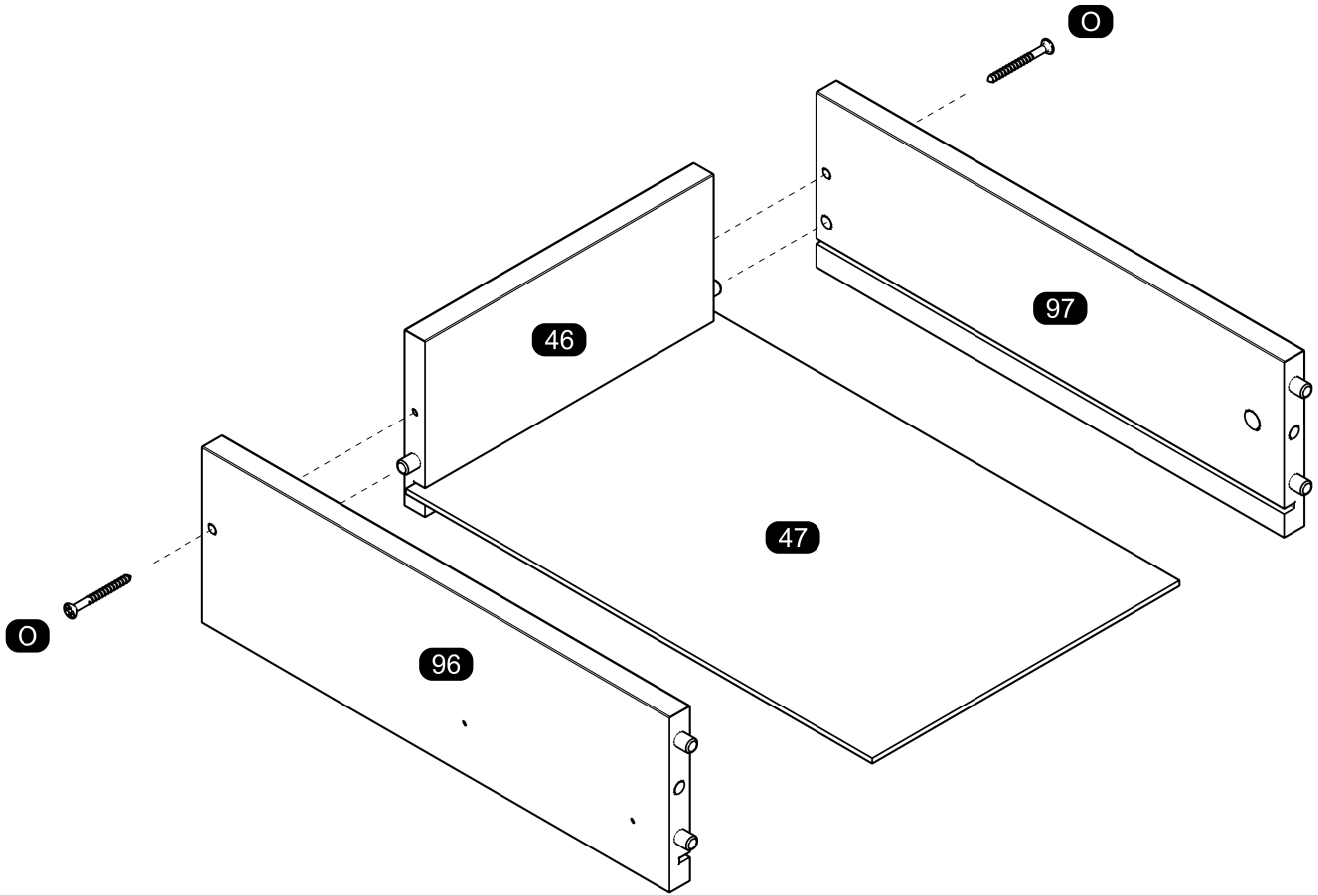

30

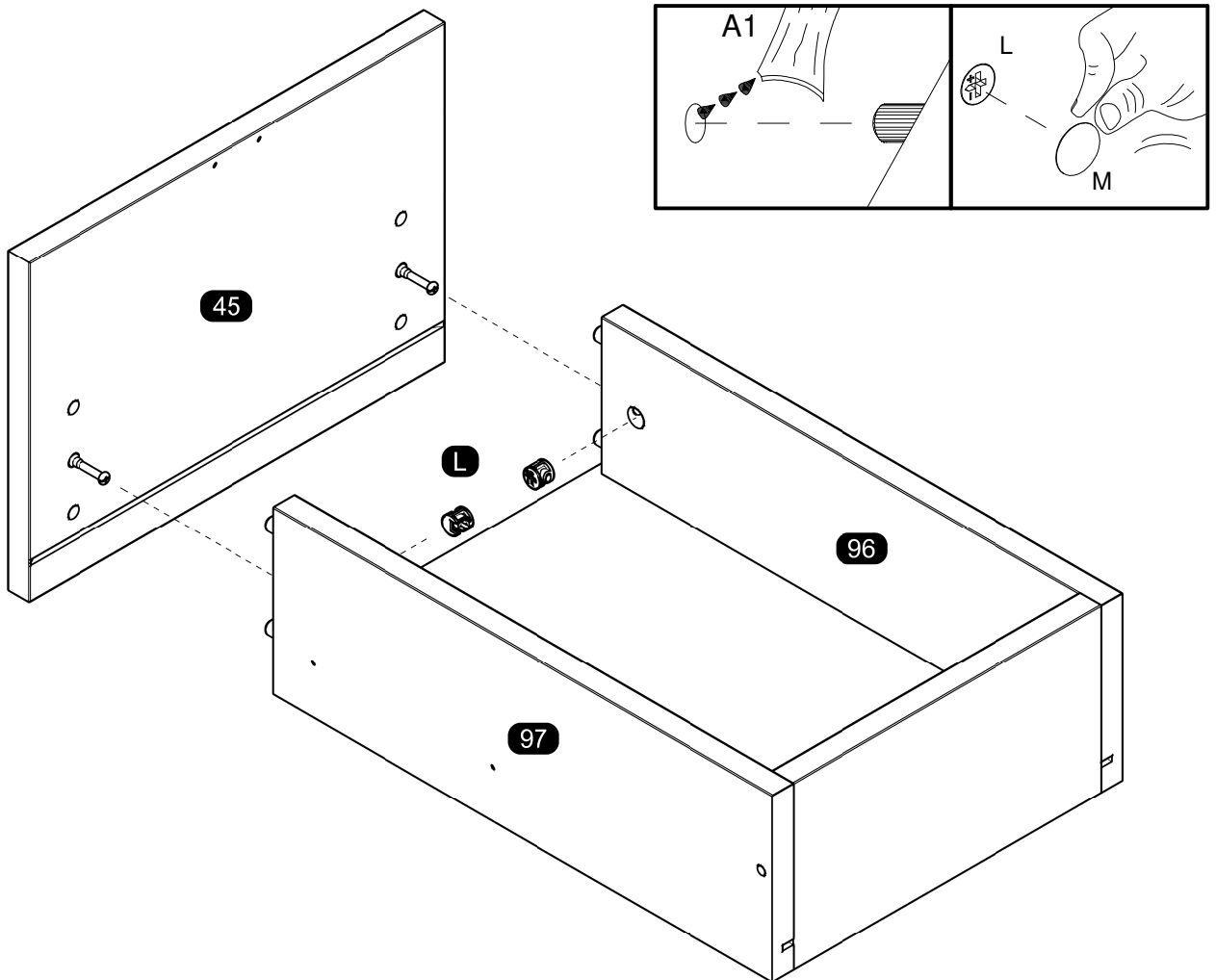

31

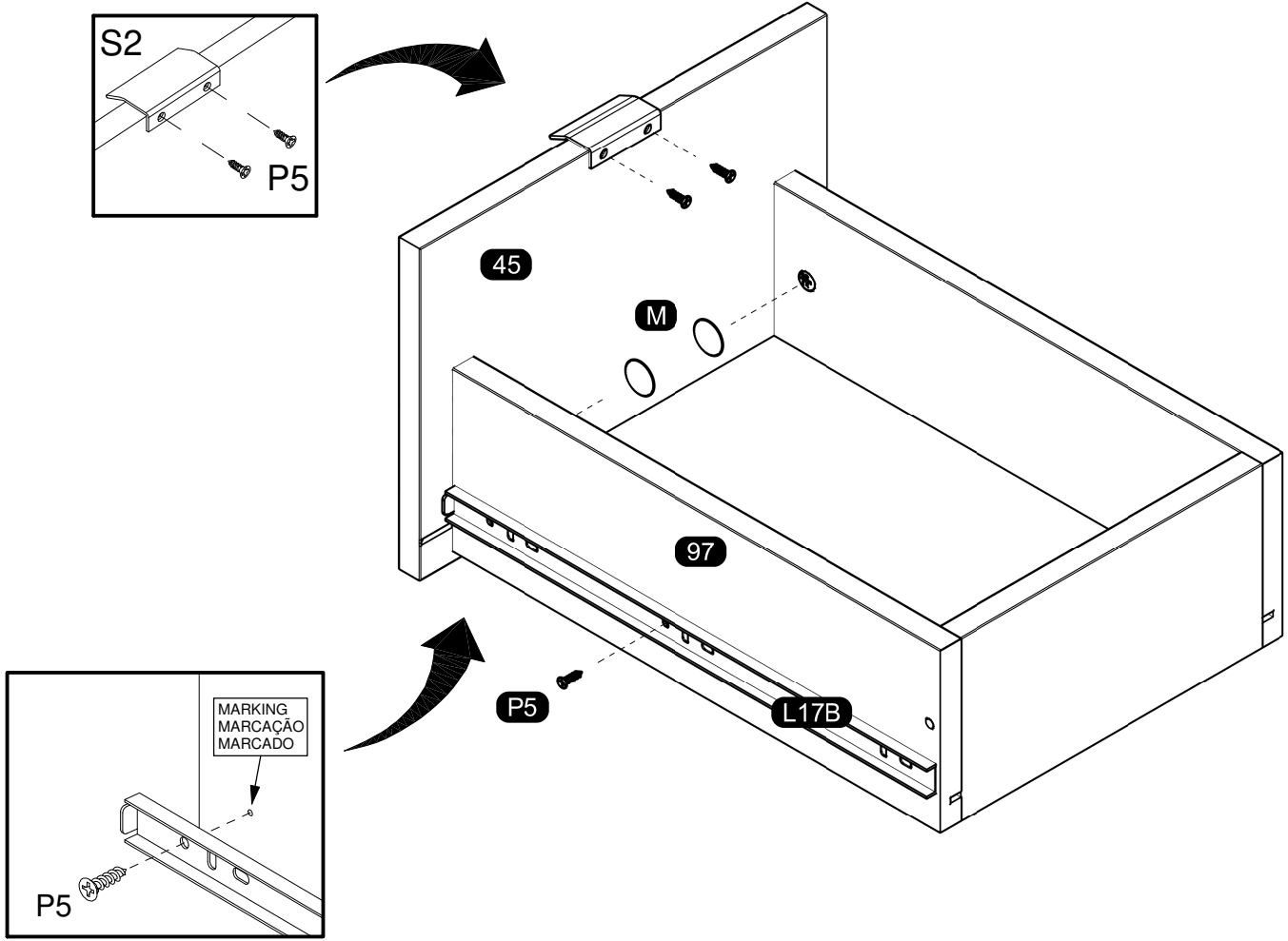

32

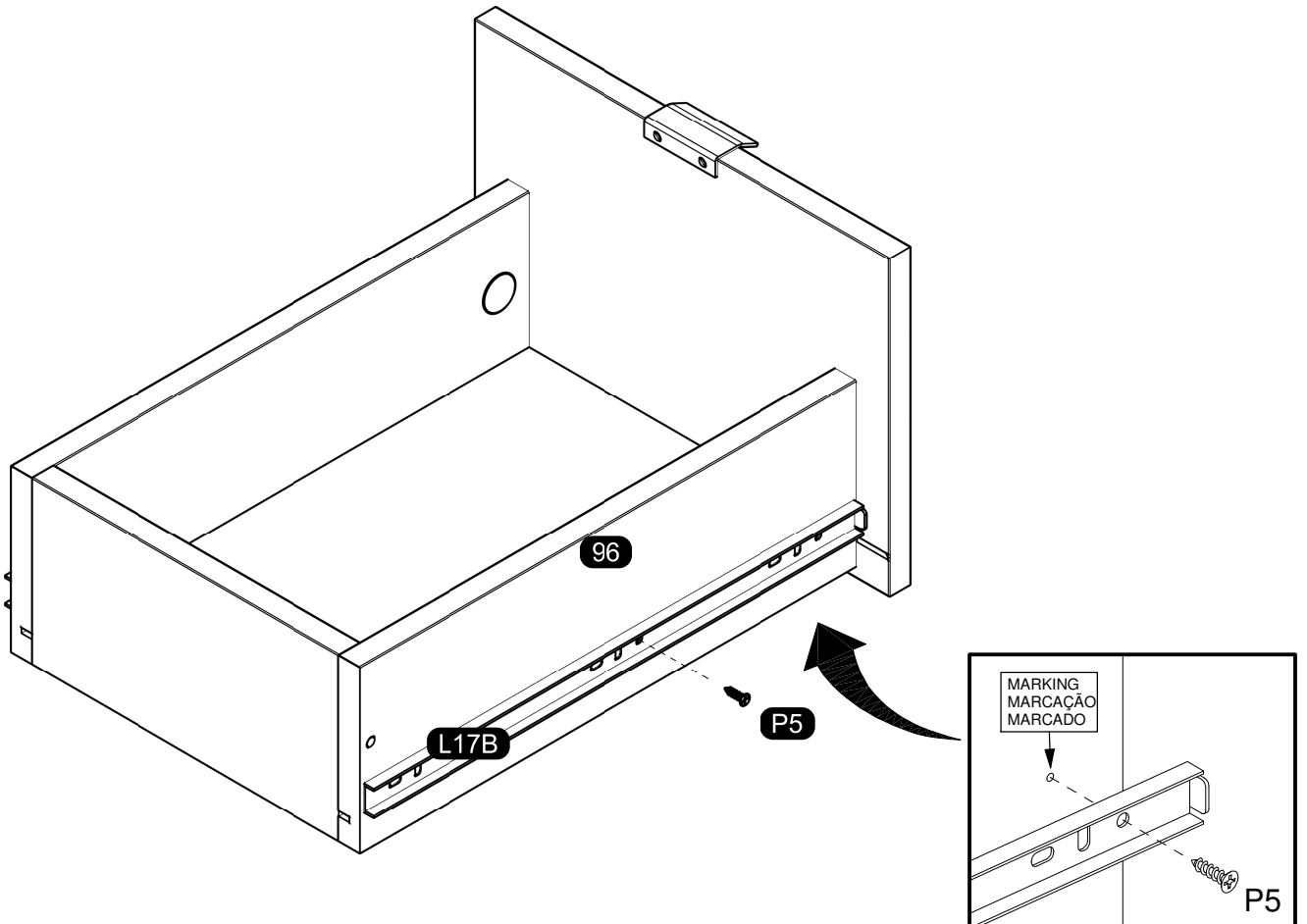

33

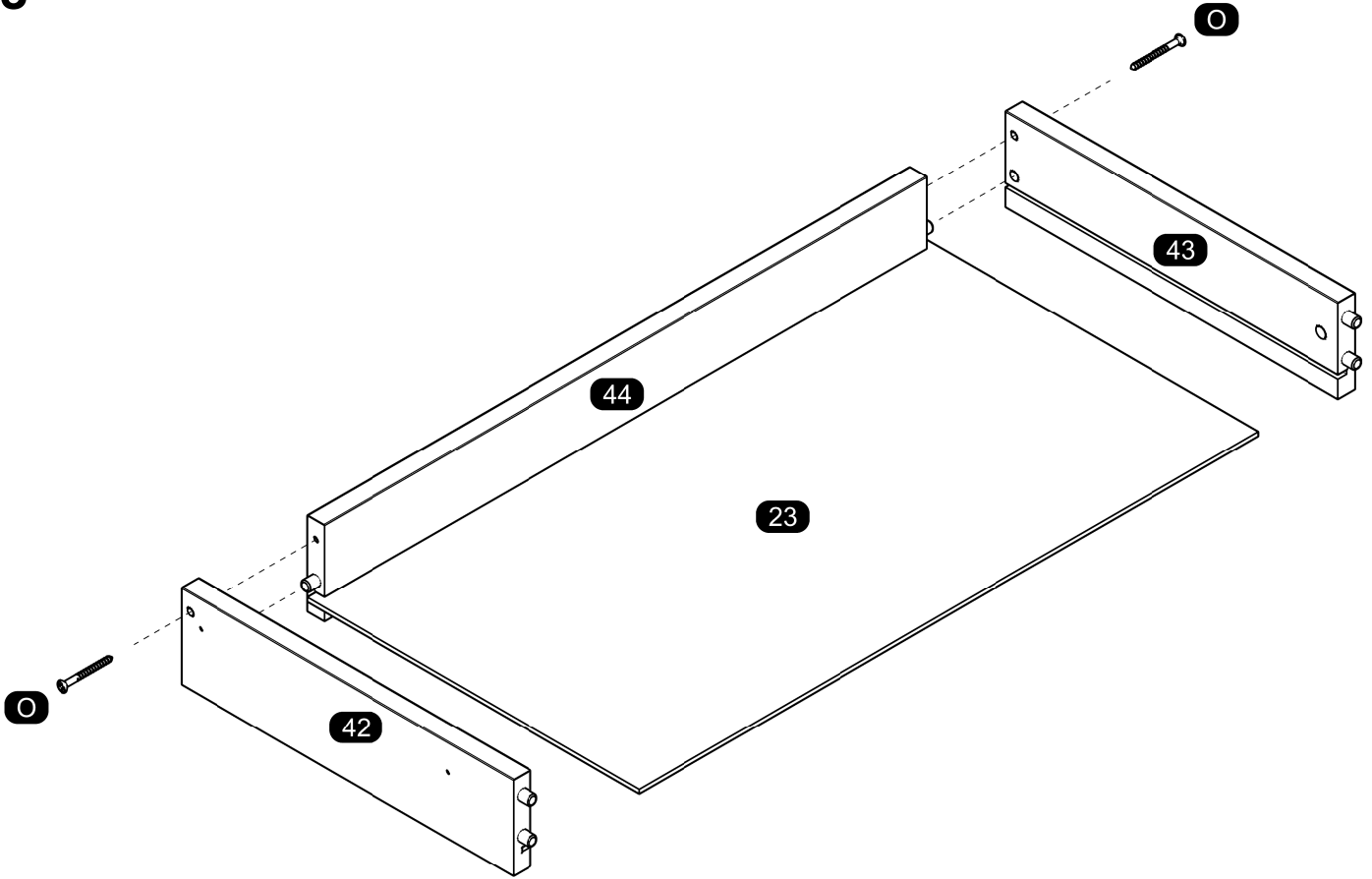

34

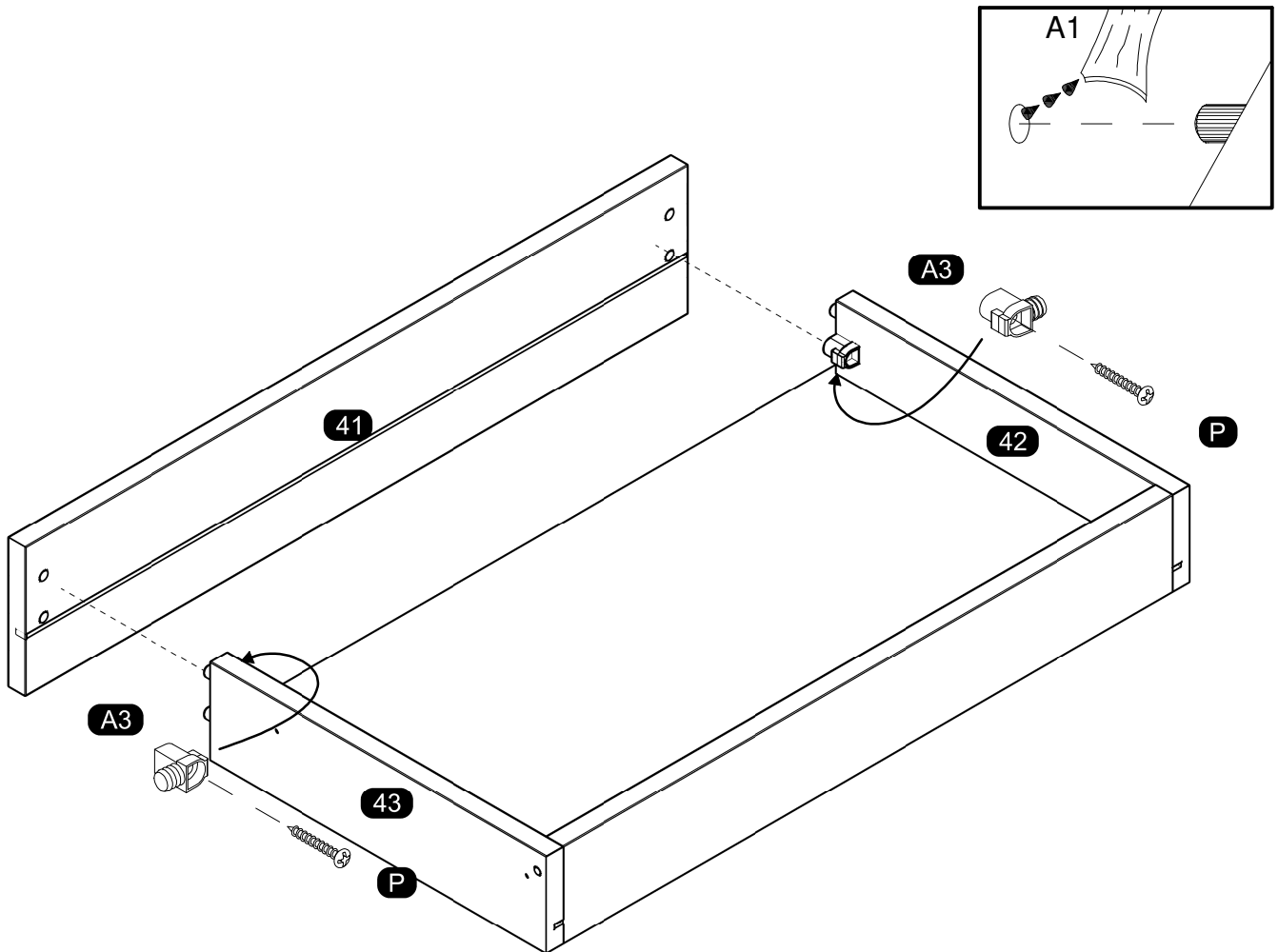

35

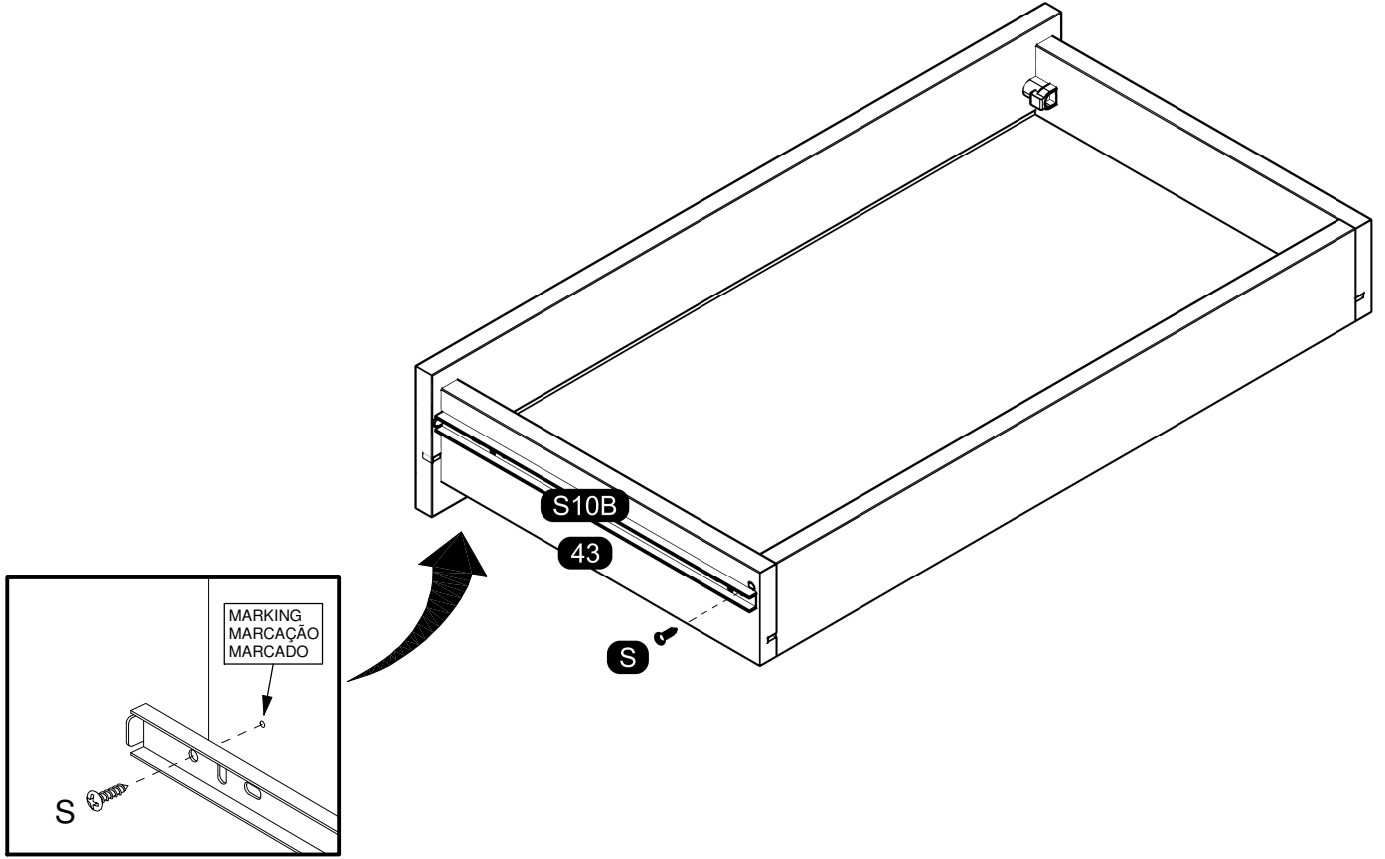

36

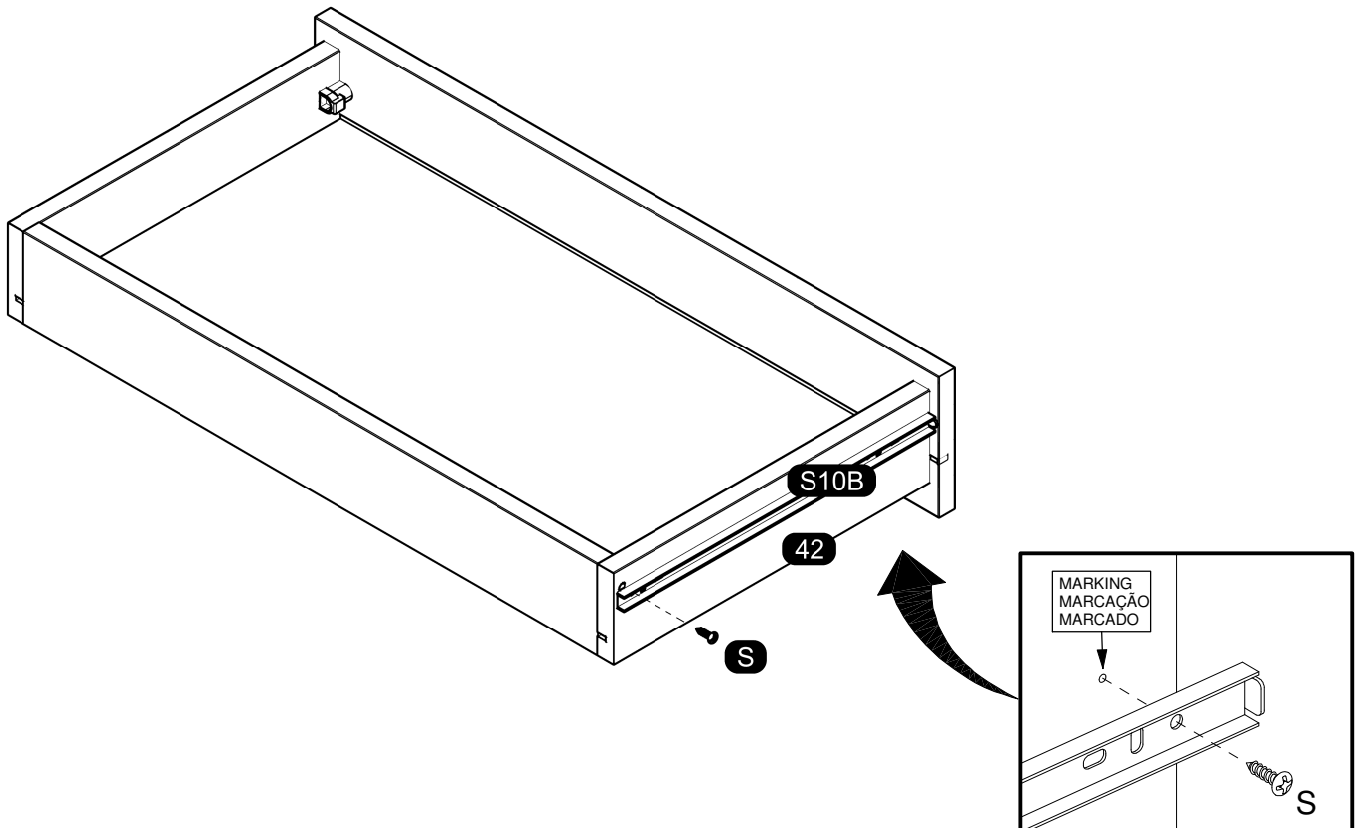

37

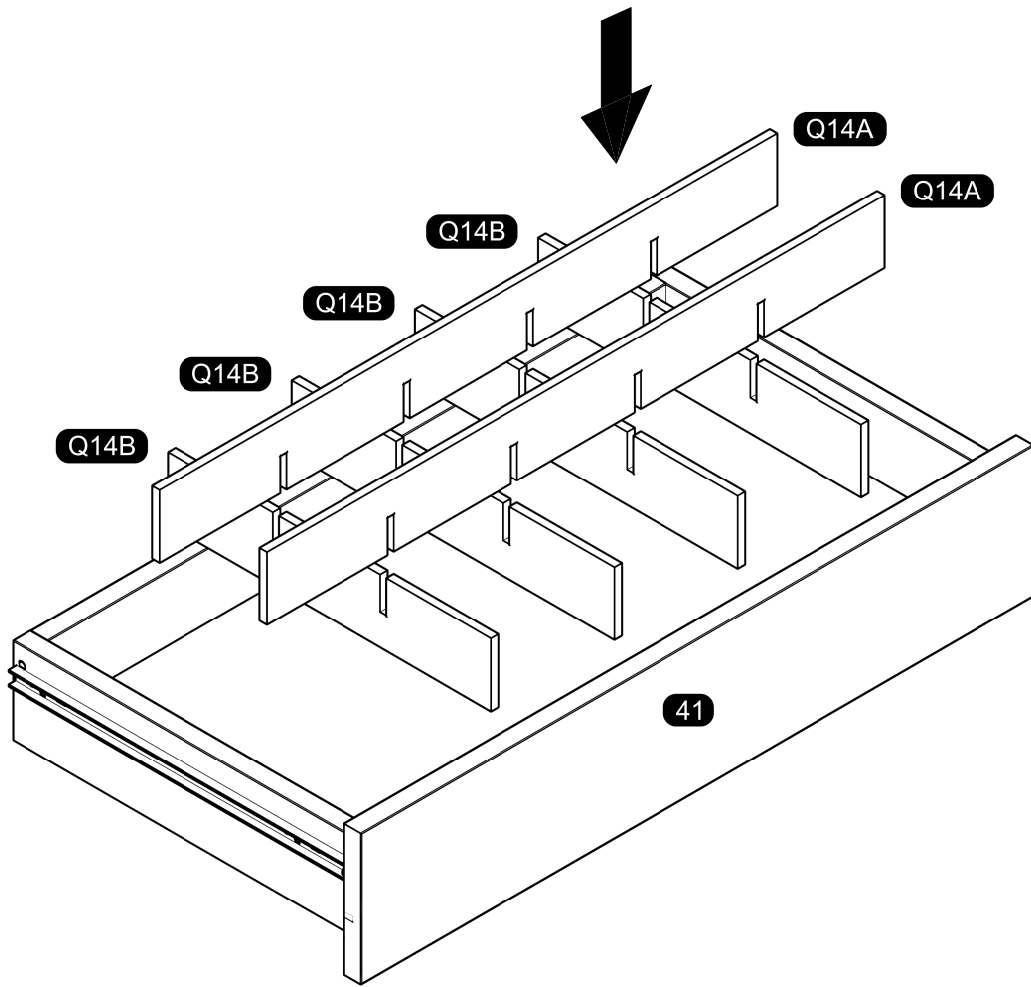

38

Drawer insertion
Inserção de gaveta
Inserción del cajón

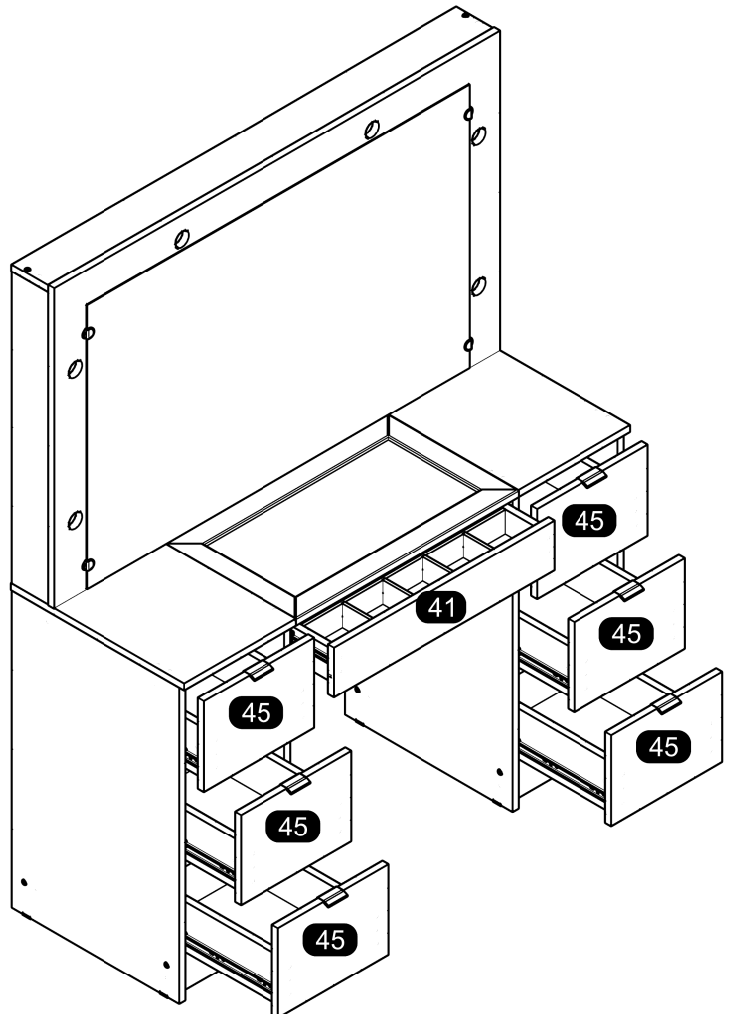
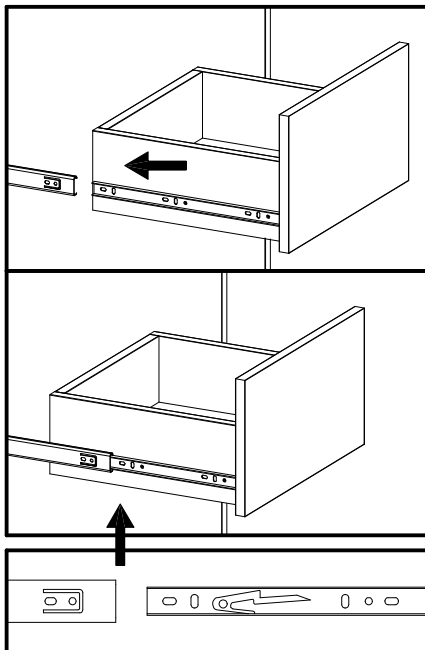

39

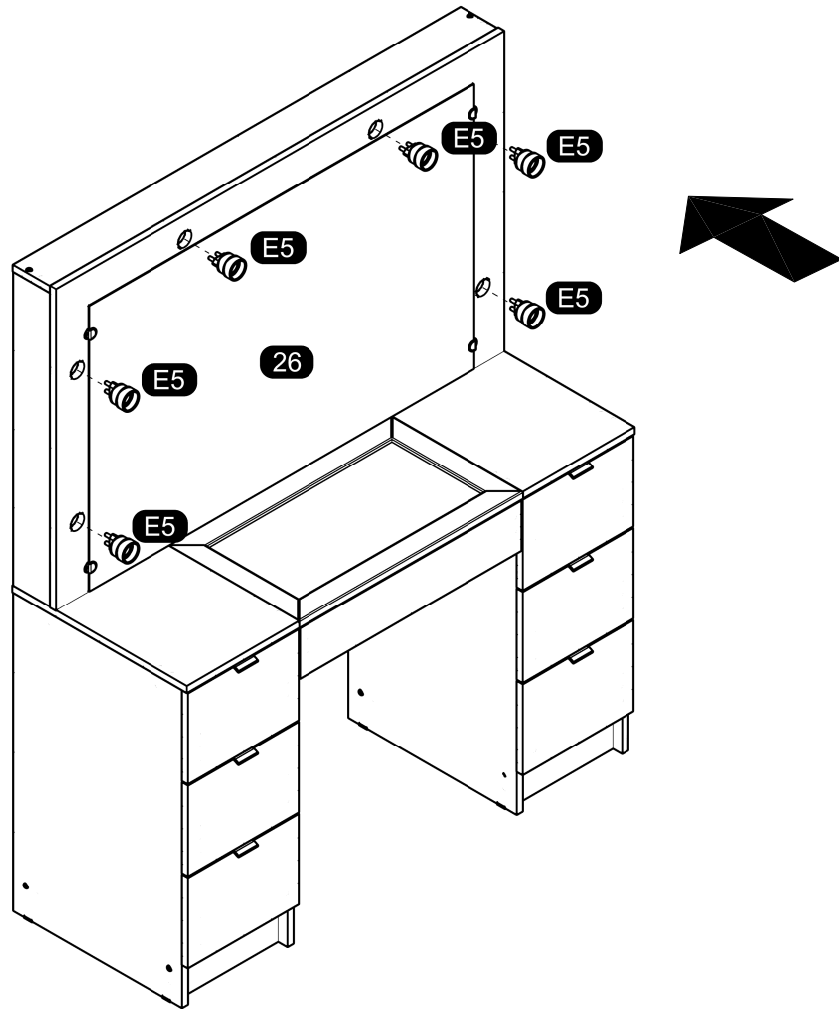

40

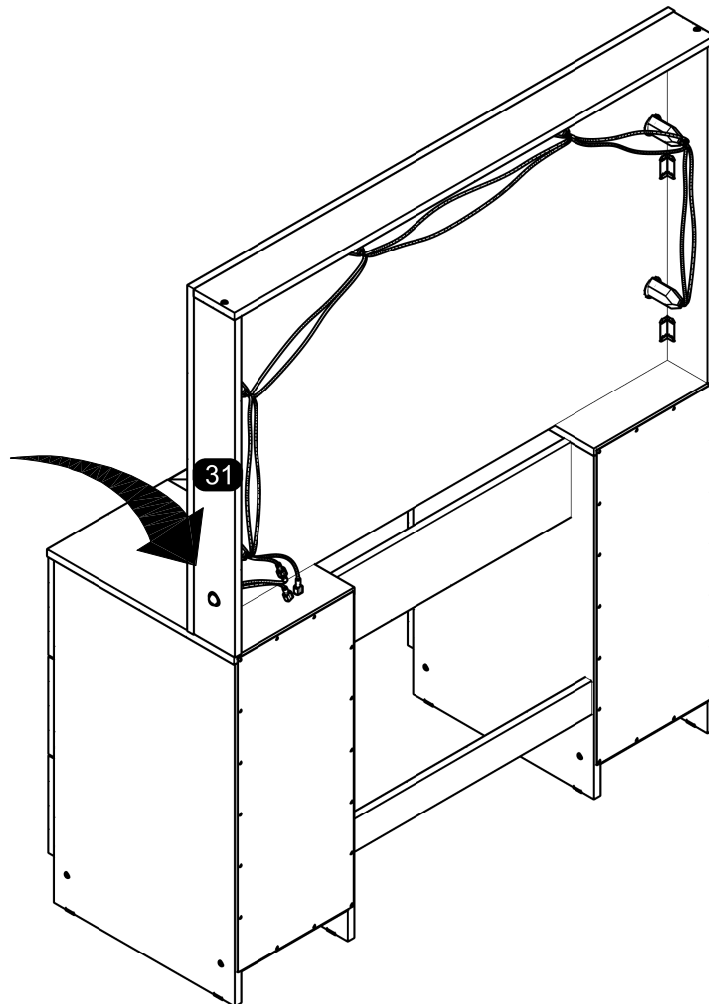
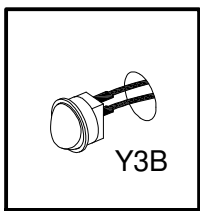

41

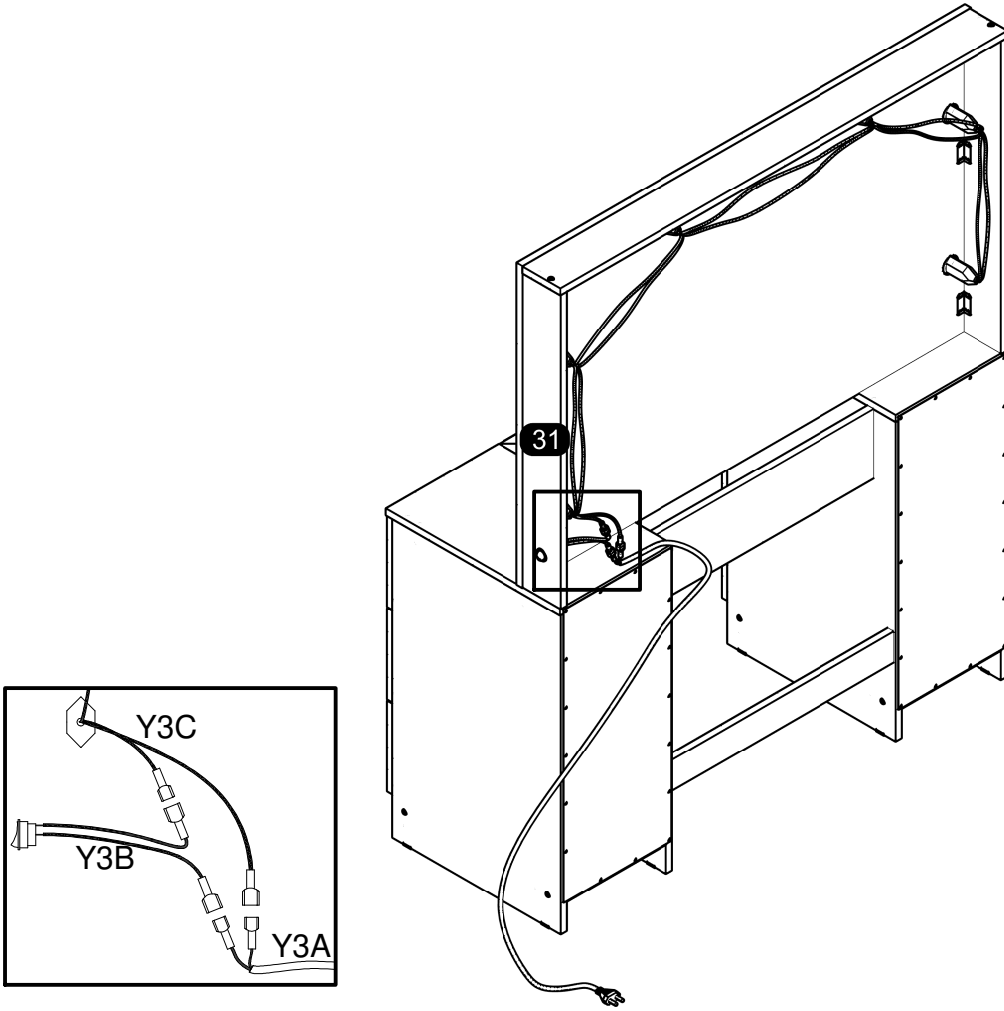

42

