

MANUAL DE MONTAGEM
Assembly instructions / Instrucciones de armado

APARADOR OSASCO

Sideboard Osasco
Aparador Osasco

Código 170196 | Revisão 00

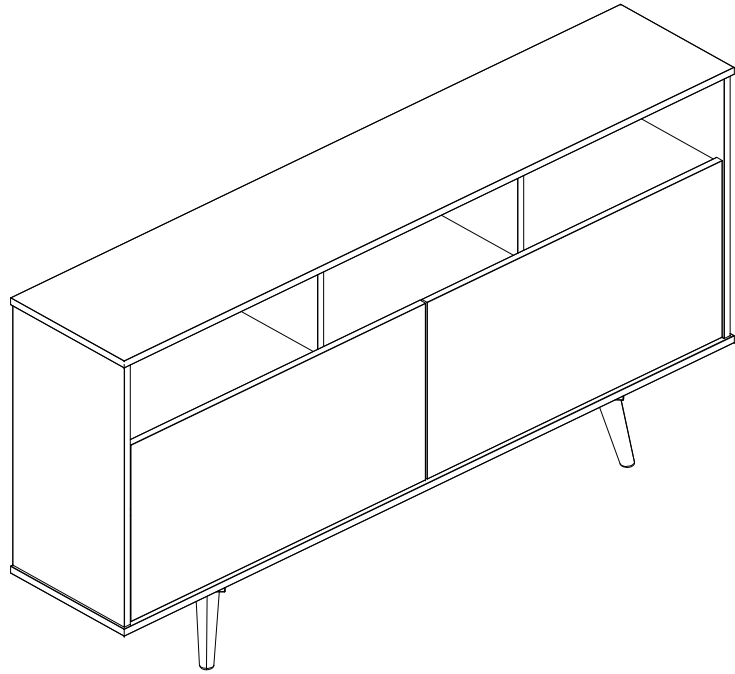

PESO MÁXIMO SUPORTADO PELAS PEÇAS, SENDO ESTE DISTRIBUÍDO UNIFORMEMENTE.

Maximum weight supported by parts, being this evenly distributed.
Peso máximo soportado por las partes, siendo esta distribuido uniformemente.

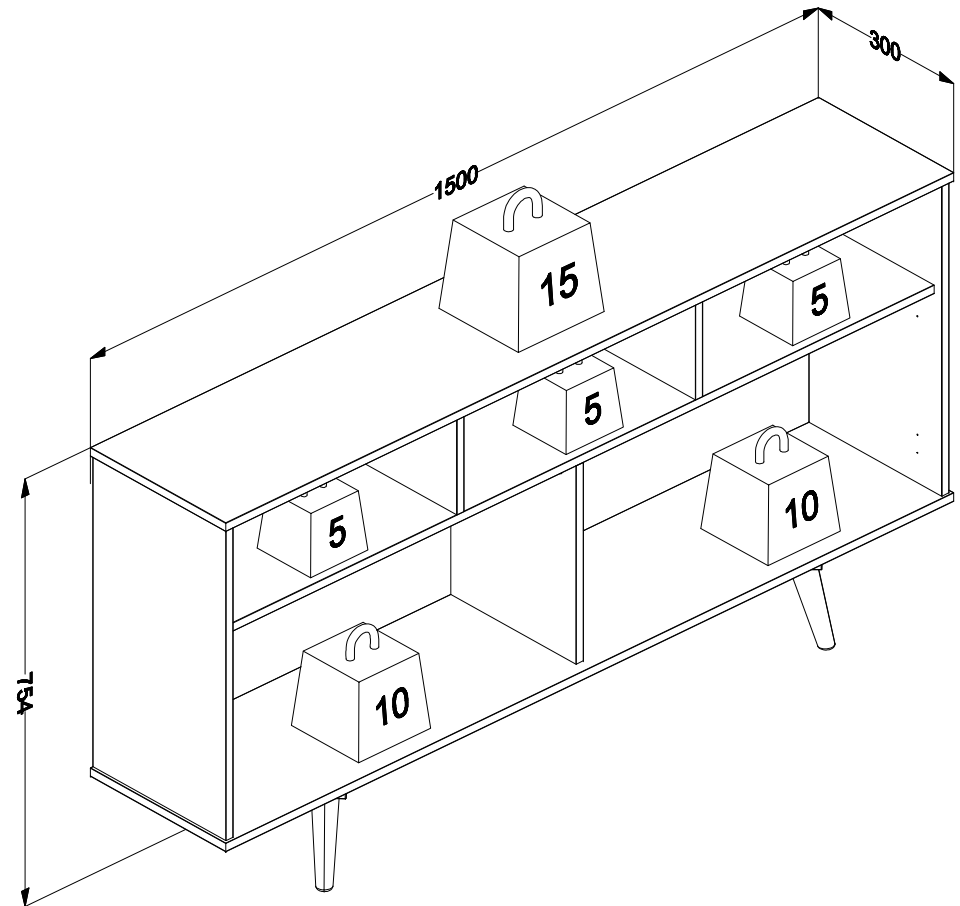

Você vai precisar de/ You will need / Usted necesitará

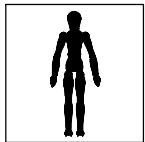

1 Pessoa
1 Person
1 Persona

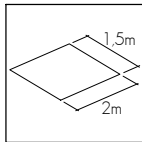

Espaço recomendado para montagem
Recommended space for assemble
Espacio recomendado para el armado

Ferramentas não inclusas
Tools not included / Herramientas no incluidas

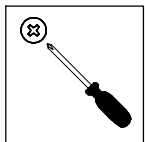

Chave Phillips
Screwdriver Phillips
Destornillador cruz

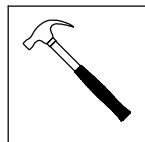

Martelo
Hammer
Martillo

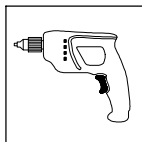

Furadeira
Drill machine
Taladro

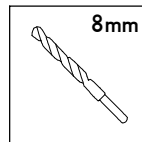

Broca
Drill bit
Taladro







* PESO EM KG/ Weight in Kg/ Peso en Kg
DIMENSÕES EM MM/ Dimensions in mm/ Dimensiones en mm

IDENTIFICAÇÃO DOS ACESSÓRIOS/ IDENTIFICATION OF ACCESSORIES/ IDENTIFICACIÓN DE ACCESORIOS

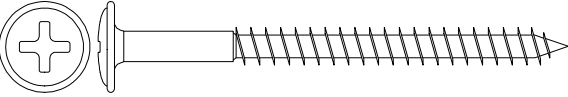
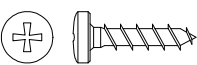
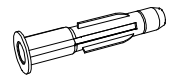
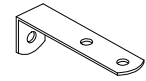
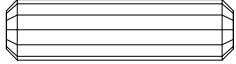
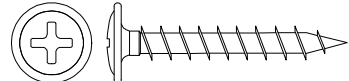
NOTAS: A separação dos acessórios antes de iniciar a montagem facilitará a mesma. Os parafusos e cavilhas estão na escala real. Em caso de dúvida na identificação, coloque o acessório sobre a imagem.

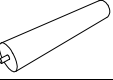
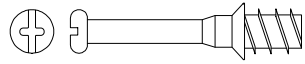
NOTES: The separation of the accessories before you start the assembly will facilitate the same. The screws and dowels are in real scale. In case of doubts about the identification, place the accessory on the image.

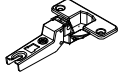
NOTAS: La separación de los accesorios antes de comenzar el armado facilitará el mismo. Los tornillos y taquetes son en escala real. En caso de dudas sobre la identificación, coloque el accesorio en la imagen.

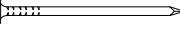
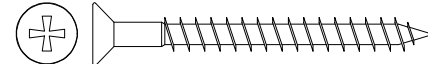
A		Parafuso flangeado Flanged head screw Tornillo de cabeza flangeada	5,0x60 mm	01	S		Parafuso panela Pan head screw Tornillo de pan	3,5x14 mm	18
B3		Bucha expansiva Bushing Tapón	8x50 mm	01					
B7		Suporte de metal Metalic bracket Soporte de metal	-	01					
E		Cavilha Wooden Dowel Taquete	8x30 mm	24					
H7		Parafuso flangeado Flanged head screw Tornillo de cabeza flangeada	4,5x30 mm	16					
I6		Suporte Pé Support Foot Pie soporte	-	04					
I7		Pé Foot Pie	-	04					
J		Haste minifix simples Simple minifix screw Tornillo minifix simple	-	14					
L		Tambor minifix Drum lock Tambor minifix	12 mm	14					
J5		Calço dobradiça alto Hinge shim Bisagra de calce	-	04					
J8		Dobradiça curva Metal hinge curve Esquina de bisagra metálica	35mm	04					
M		Tapa furo adesivo Bore patch adhesive Tapones adhesivo	-	10					
N		Prego Nail Clavo	10 x10	30					
O		Parafuso chato Flat head screw Tornillo de cabeza plana	4,5x45 mm	10					

IDENTIFICAÇÃO DAS PEÇAS/ PARTS IDENTIFICATION/ IDENTIFICACIÓN DE LAS PIEZAS

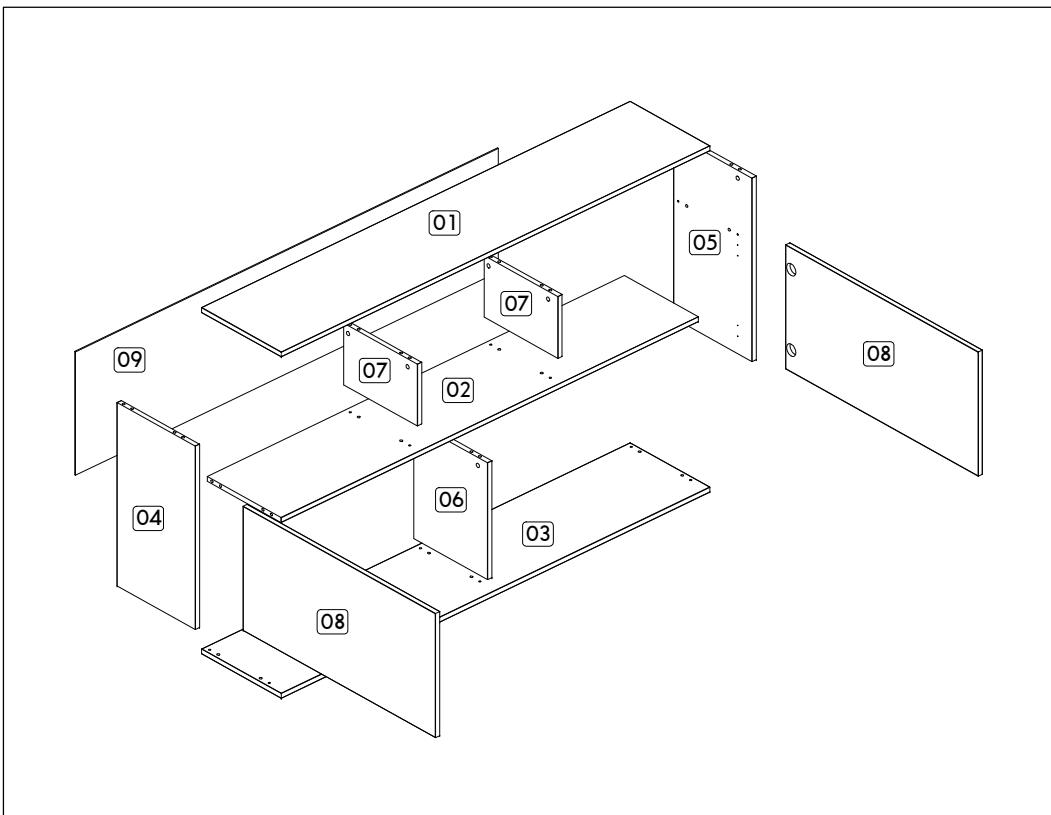

Nº	DESCRIÇÃO - DESCRIPTION - DESCRIPCIÓN	MEDIDAS-MEASURES - MEDIDAS (mm)	QTD.
01	Tampo - Top - Tapa	1500 x 300 x 15	01
02	Prateleira - Shelf - Repisa	1460 x 278 x 15	01
03	Base inferior - Bottom base - Base inferior	1500 x 300 x 15	01
04	Lateral esquerda - Left side - Lateral izquierda	550 x 295 x 15	01
05	Lateral direita - Right side - Lateral derecha	550 x 295 x 15	01
06	Divisão inferior - Bottom division - Division inferior	350 x 278 x 15	01
07	Divisão superior - Top division - Division superior	185 x 278 x 15	02
08	Porta - Door - Puerta	725 x 372 x 15	02
09	Costa - Backboard - Fondo	1480 x 370 x 03	01

PRÉ-MONTAGEM/ PRE-ASSEMBLE/ PRE ARMADO

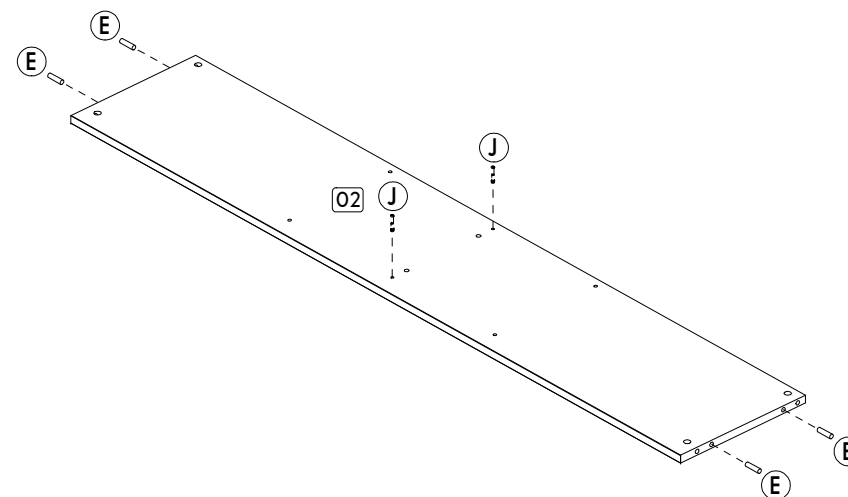
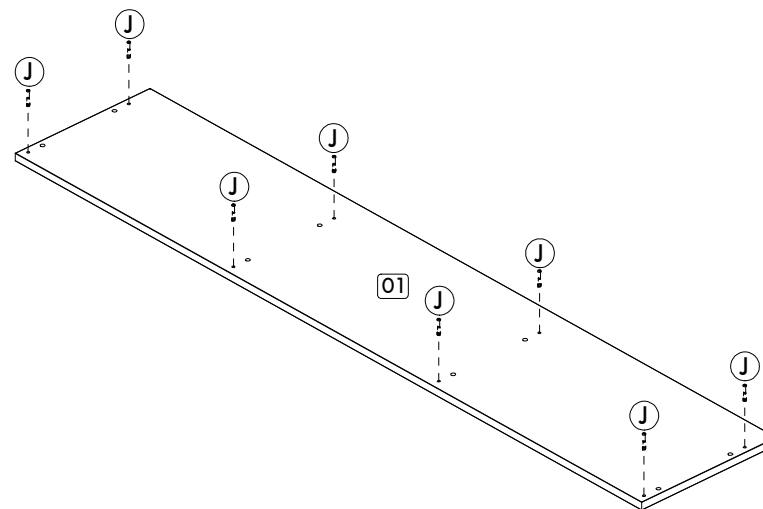

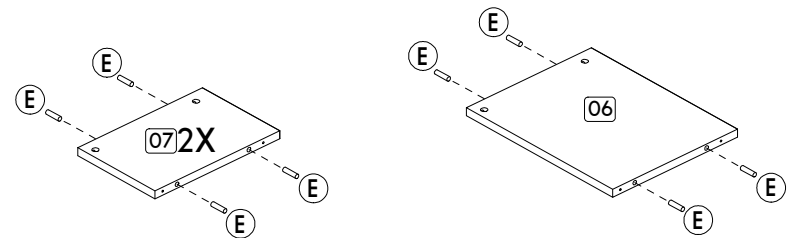
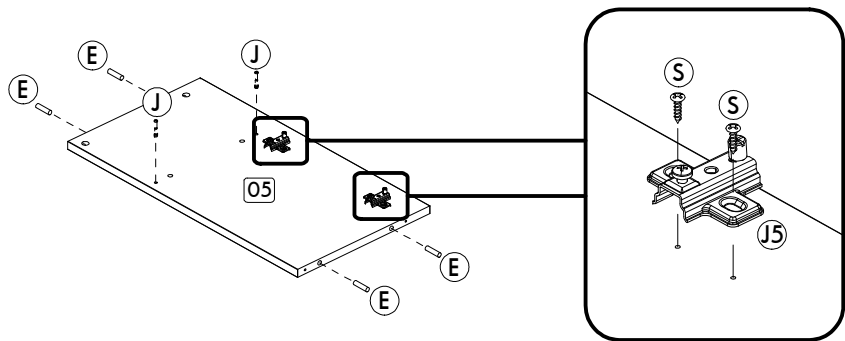
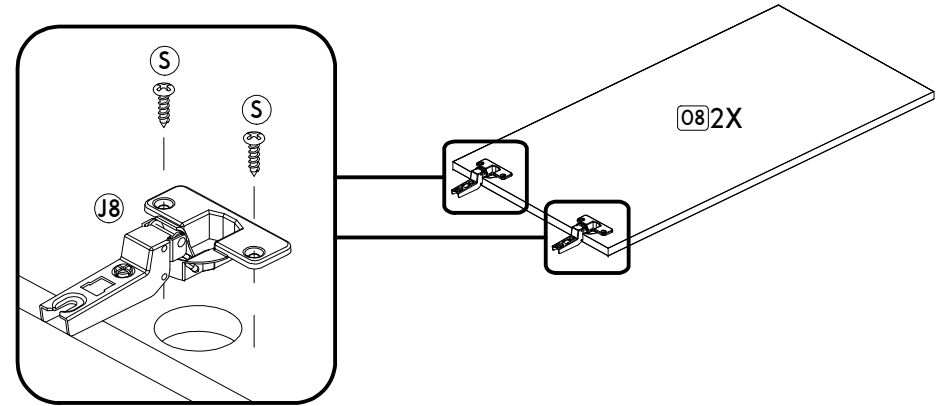
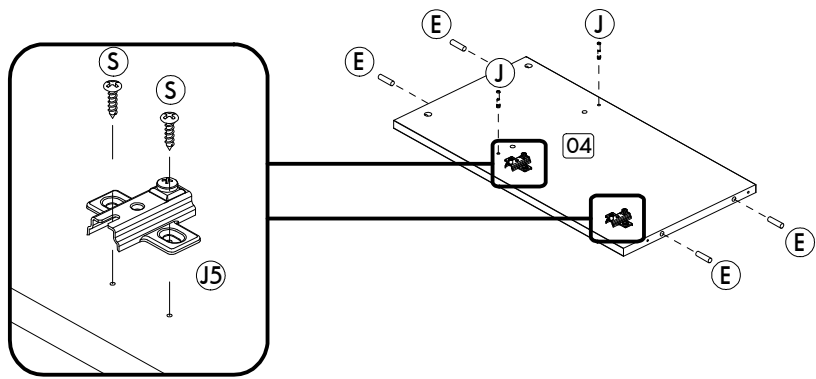

Passo/ Step/ Paso 01

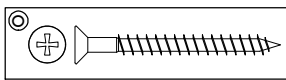
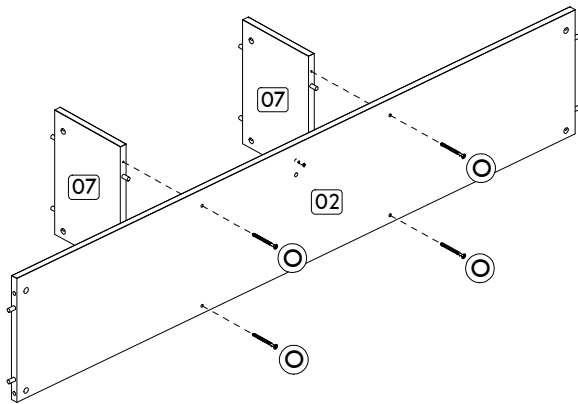

Passo/ Step/ Paso 02

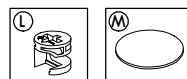
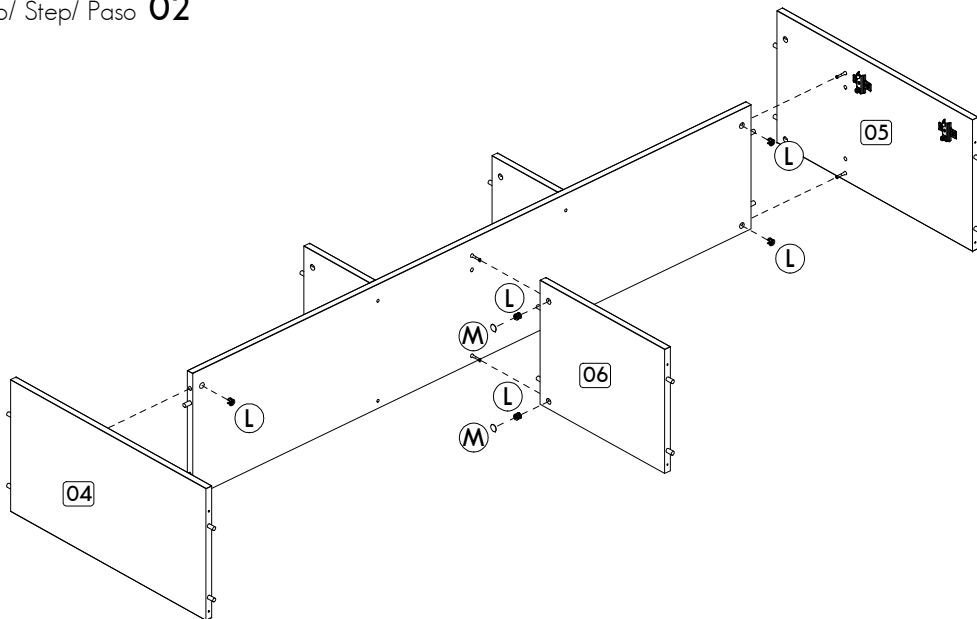

Passo/ Step/ Paso 03

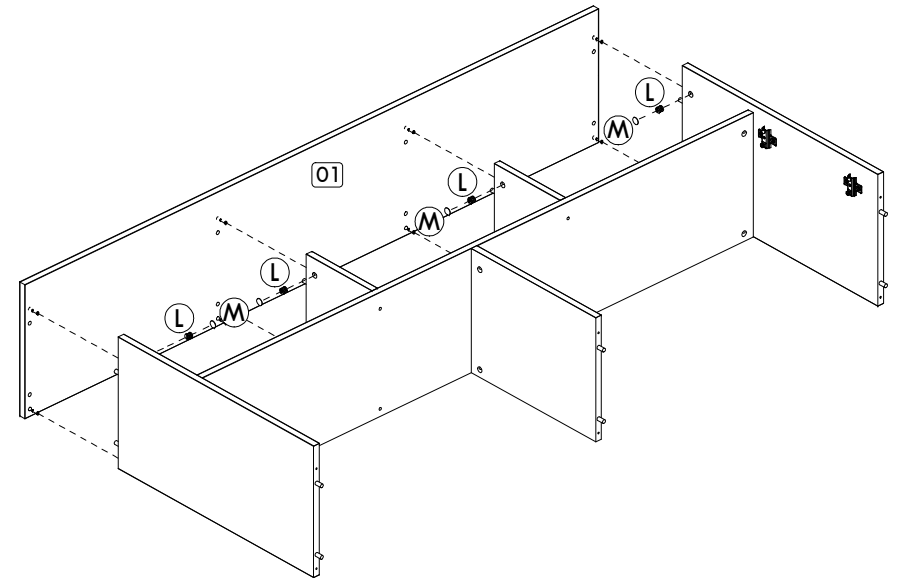

Passo/ Step/ Paso 04

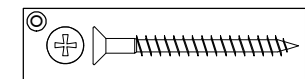
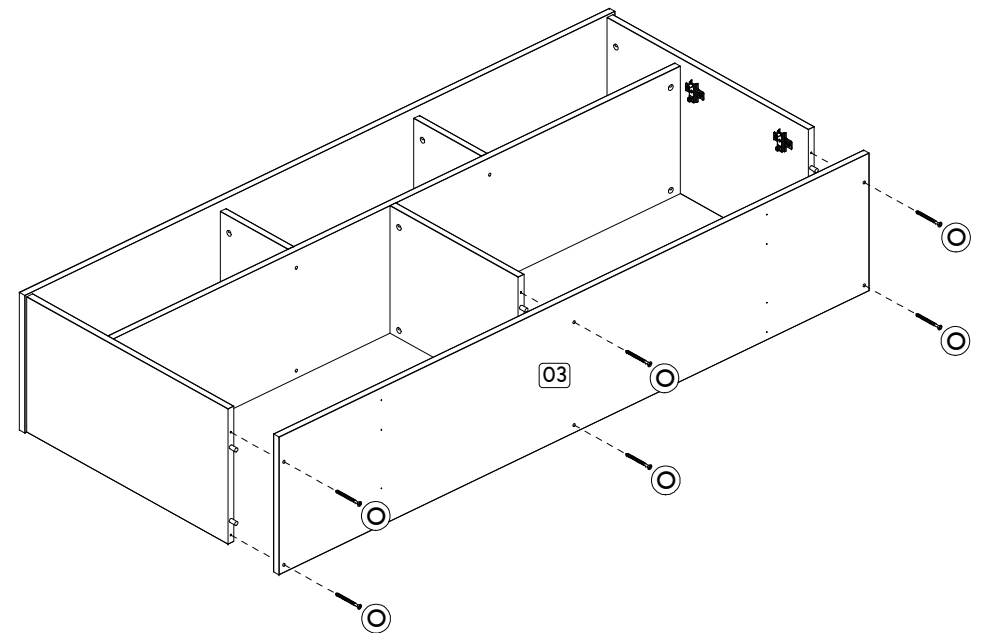

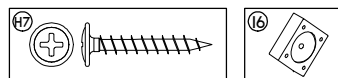
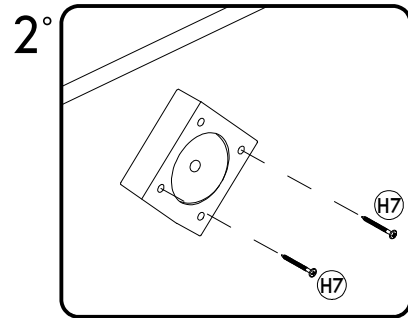
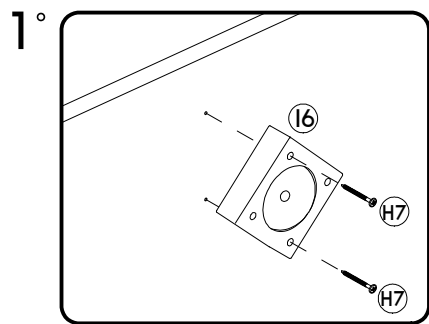
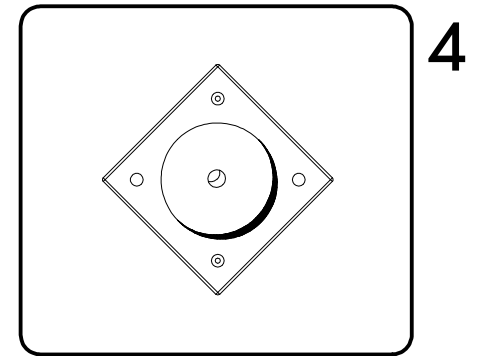
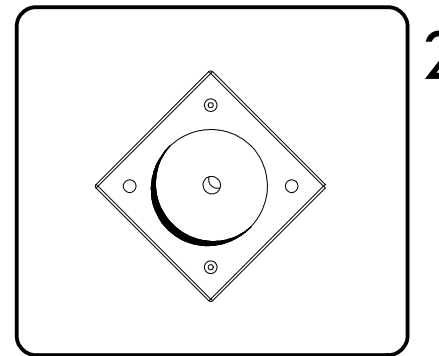
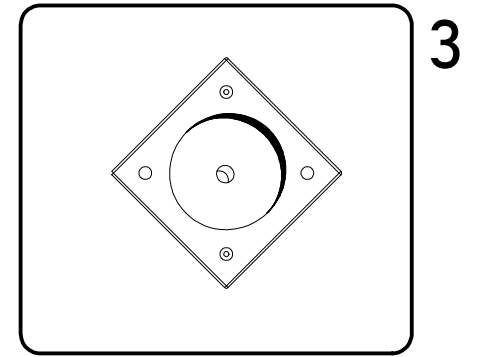
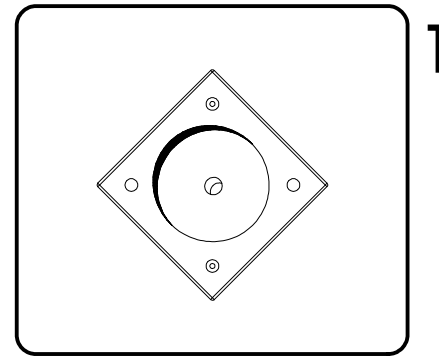
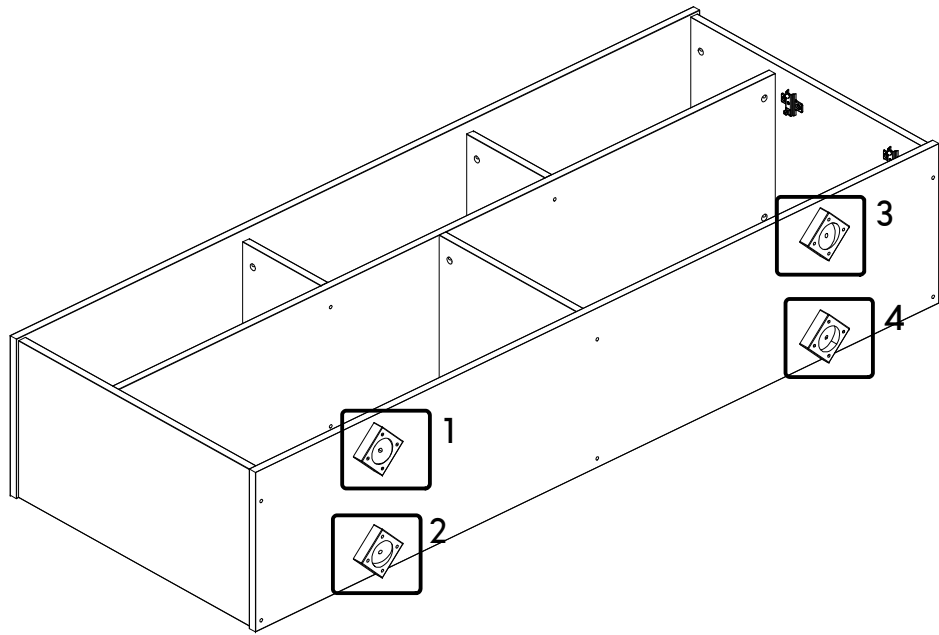

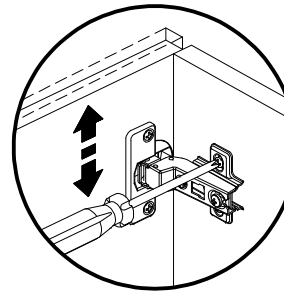
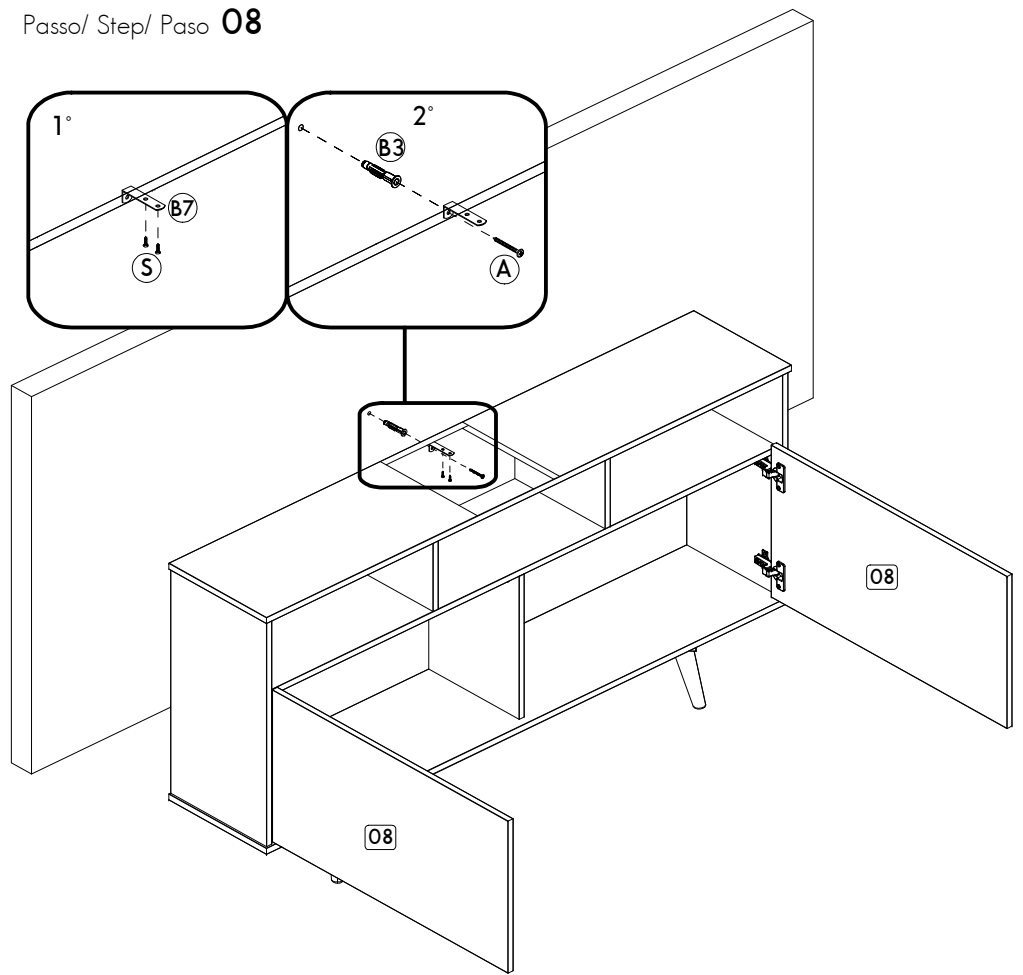
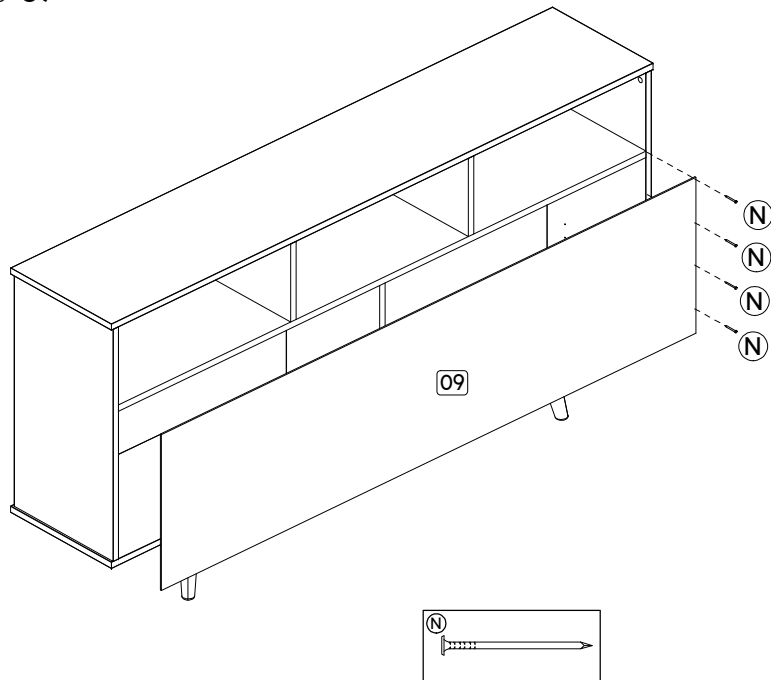
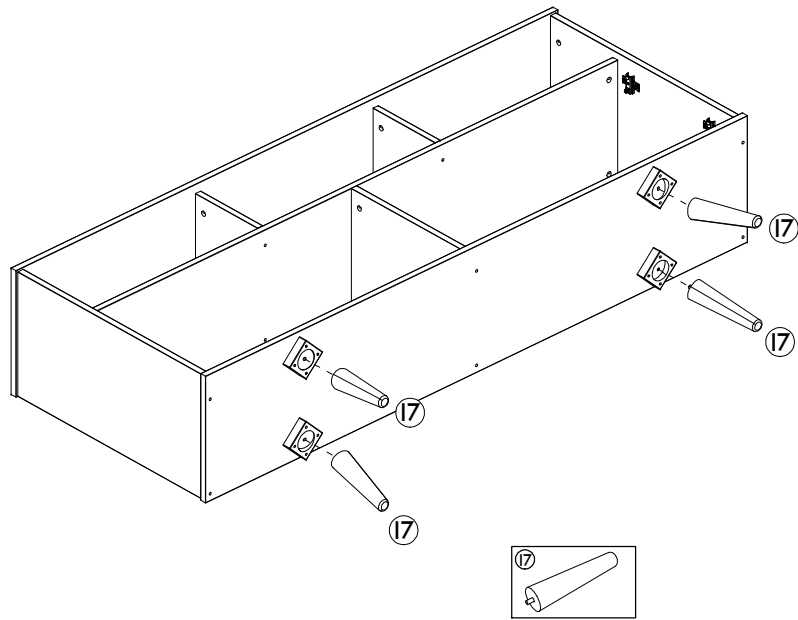

Regulagem Vertical
Ajuste Vertical
Vertical Adjustment

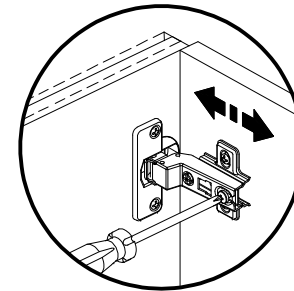

Regulagem Profundidade
Ajuste Profundidad
Depth Adjustment

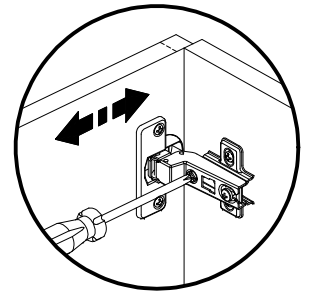

Regulagem Horizontal
Ajuste Horizontal
Horizontal Adjustment

