

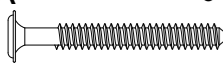











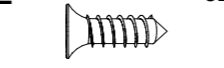



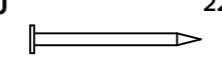
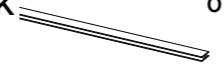

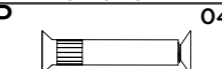

## Lista de Peças | Lista de piezas | List of parts

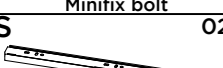
Item	Caixa Caja Box	Qty	Descrição   Descripción   Description	Medidas (mm)   Dimensions (mm)   Size (measurements) (mm)
01	1/1	01	Rodapé Frontal   Frente pie de página   Front Footer	800x145x15
02	1/1	02	Rodapé Lateral   Pie de página Side   Side Footer	450x145x15
03	1/1	01	Rodapé Traseiro   Pie de página trasera   Rear Footer	768x145x15
04	1/1	01	Base   Base   Base	800x490x15
05	1/1	01	Lateral esquerda   Lateral izquierda   Left side	660x490x15
06	1/1	01	Travessa frontal   Travesaño frontal   Front crossbar	769x60x15
07	1/1	01	Travessa traseira   Travesaño trasero   Rear bumper	769x60x15
08	1/1	01	Lateral direita   Lateral derecha   Right side	660x490x15
09	1/1	02	Fundo   Fondo   Bottom	687x396x3
10	1/1	02	Frente de gaveta   Frente de cajón   Front of drawer	796x330x15
11	1/1	04	Lado de Gaveta   Lado del cajón   Drawer Side	400x180x15
12	1/1	02	Fundo de gaveta   Fondo de cajón   Bottom of drawer	725x411x3
13	1/1	02	Ripa de trás   Malla detrás   Rear lath	744x180x15
14	1/1	02	Travessa   Travesaño   Crossbar	400x60x15

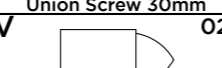
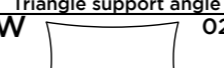
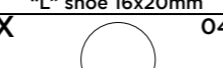
## Ferragens | Herrajes | Hardware

<b>A</b>	04x	<b>B</b>	03x	<b>C</b>	02x	<b>D</b>	14x	<b>E</b>	62x	<b>F</b>	01x
	Parafuso 5,0x50mm FLA. Tornillo 5,0x50mm FLA. Screw 5,0x50mm FLA.		Parafuso 4,5x50mm CHT. Tornillo 4,5x50mm CHT. Screw 4,5x50mm CHT.		Parafuso 3,0x30mm CHT. Tornillo 3,0x30mm CHT. Screw 3,0x30mm CHT.		Parafuso 3,5x40mm CHT. Tornillo 3,5x40mm CHT. Screw 3,5x40mm CHT.		Parafuso 4,0x14mm CHT. Tornillo 4,0x14mm CHT. Screw 4,0x14mm CHT.		Etiqueta resinada Henn Etiqueta resinada Henn Henn resin label
<b>G</b>	04x	<b>H</b>	40x	<b>I</b>	04x	<b>J</b>	22x	<b>K</b>	01x	<b>L</b>	08x
	Parafuso M4x20mm CHT. ZB Tornillo M4x20mm CHT. ZB Screw M4x20mm CHT. ZB		Cavilha 8x25mm Cinta 8x25mm Dowel 8x25mm		Prego 12x12mm Anelado Clavo 12x12mm Anillado Ringed Nails 12x12mm		Prego 10x10mm Clavo 10x10mm Nail 10x10mm		Perfil "I" 672mm Perfil en "I" de 672 mm "I" profile 672mm		Cantoneira plástica Cantoneira plástica Plastic angle brackets
<b>M</b>	08x	<b>N</b>	08x	<b>O</b>	02x	<b>P</b>	04x	<b>Q</b>	08x	<b>R</b>	04x
	Parafuso minifix Tornillo minifix Minifix bolt		Tambor minifix Tambor minifix Minifix drum		Puxador Concha Tirador Concha Shell Handle		Parafuso União 30mm Tornillo Unión 30mm Union Screw 30mm		Cantoneira suporte triangular Cantoneira soporte triangular Triangle support angle		Sapata "L" 16x20mm Zapata "L" 16x20mm "L" shoe 16x20mm
<b>S</b>	02x	<b>T</b>	02x	<b>U</b>	04x	<b>V</b>	02x	<b>W</b>	02x	<b>X</b>	04x
	Corrediza telescópica Diapositivas telescópicas Telescopic slides		Suporte de fixação Soporte de fijación Mounting bracket		Bucha plástica 8mm Bucha de plástico 8mm 8mm plastic bushing		Giz de correção Tiza de corrección Chalk of correction		Sachê de cola Bolsa de pegamento Glue bag		Adesivo tapa parafuso 17mm Adhesivo tapón de tornillo 17mm Bolt cover adhesive 17mm
<b>Y</b>	04x										
	Adesivo tapa parafuso 10mm Adhesivo tapón de tornillo 10mm Bolt cover adhesive 10mm										

 O parafuso (P) deve ser usada somente quando este módulo for acoplado a outro módulo componível Henn.

 El tornillo (P) se debe utilizar sólo cuando el módulo está conectado a otro módulo componible Henn.

 The screw (P) should be used only when this module is attached to another Henn modular module.

## RECOMENDAÇÃO

Para fixar o móvel na parede usar o suporte de fixação (T), o parafuso 4,0x14mm CHT (E), a Bucha 8mm (U) e o parafuso 5,0x50mm FLA (A).

## RECOMENDACIÓN

Para conectar el móvil a la pared con el soporte (T), tornillo 4,0x14mm CHT (E), el casquillo de 8 mm (U) y el 5,0 x50mm tornillo FLA (A).

## RECOMMENDATION

To fix the furniture to the wall use the mounting bracket (T), the 4,0x14mm CHT (E) screw, the 8mm bushing (U) and the 5,0x50mm FLA screw (A).

HENN

Ind. e Com. de Móveis Henn  
Mondai - SC - Brasil

☎ +55 49 3674.3500

📧 @moveishenn  
www.henn.com.br

## INSTRUÇÕES DE MONTAGEM

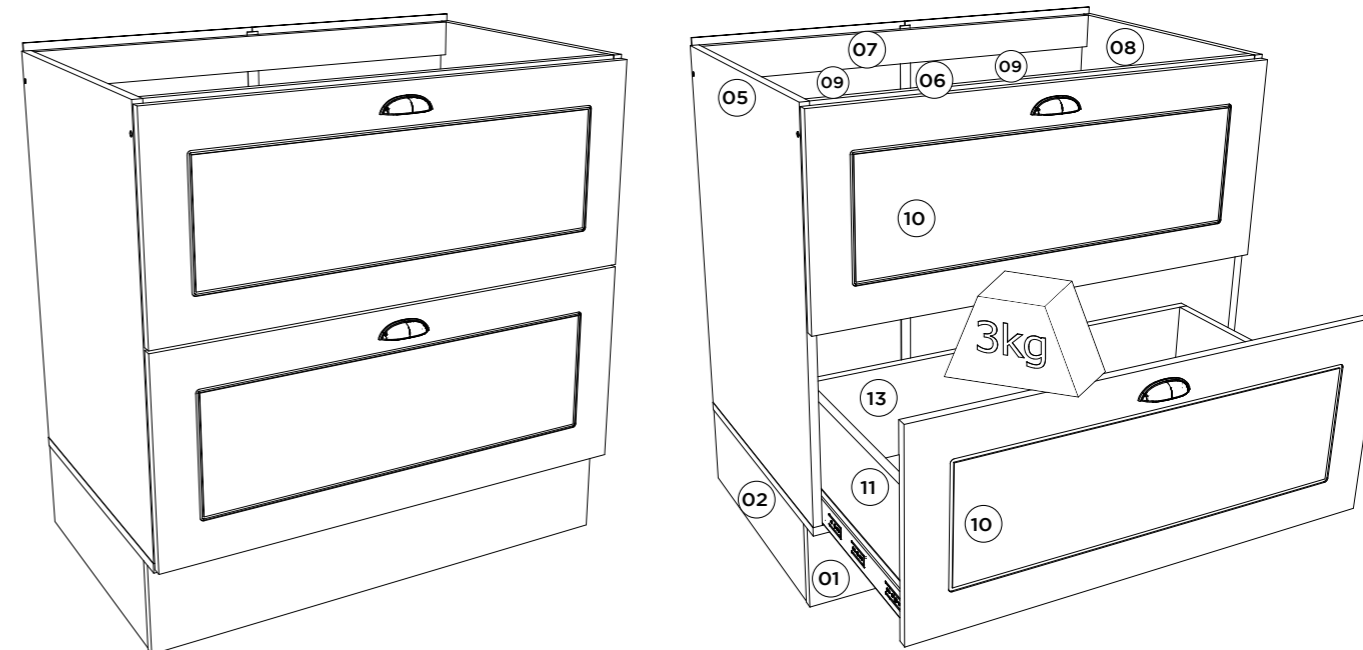
INSTRUCCIONES DE MONTAJE  
ASSEMBLY INSTRUCTIONSBalcão 02 Gavetas 800mm Americana |  
Mostrador Americana con 2 cajones de 800mm | American-style counter with 2 drawers, 800mm.C371-05 Branco HP  
C371-131 Cinza

Pesos máximos recomendados com carga distribuída  
Peso máximo recomendado con la carga distribuída  
Recommended maximum weights with evenly distributed.

Requisitos para montagem  
Requisitos para la montaje  
Assembly Requirements

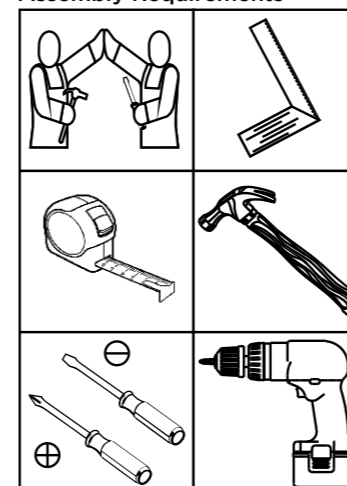

Imagens meramente ilustrativas, não acompanha o produto.  
Imágenes ilustrativas, no incluidas con el producto.  
Illustrative images, not included with the product.

## AVISO

Para limpeza de seu móvel, use uma flanela seca ou umedecida, e não utilize produtos químicos que possam danificar seu produto.

## SISTEMA DE MONTAGEM

O sistema de montagem dos produtos, funciona de acordo com a ordem crescente dos números indicados no desenho. Ex: 01, 02, 03, 04... até a conclusão da montagem.

## ASSISTÊNCIA TÉCNICA

Para solicitação de Assistência Técnica você consumidor deverá entrar em contato com o Lojista o qual você realizou a compra deste produto e solicitar a assistência técnica das peças avariadas. A garantia abrange todas as peças, partes e componentes que eventualmente venham apresentar defeito de fabricação no prazo de 03 (três) meses, contando a partir da entrega do produto ao consumidor, mediante nota fiscal de compra. Se houver qualquer alteração na estrutura do produto ou ocorrer defeito por negligência do montador/consumidor em relação a instrução de montagem e manuseio, não será fornecido assistência técnica gratuita.

## ADVERTENCIA

Para limpieza de su móvil, use una flanela seca o húmeda, y no utilice productos químicos que puedan dañar su producto.

## SISTEMA DE MONTAJE

El sistema de montaje de los productos funciona de acuerdo con el orden creciente de los números indicados en el dibujo. Ej.: 01, 02, 03, 04... hasta la conclusión del montaje.

## ASISTENCIA TÉCNICA

Para solicitar Asistencia Técnica, el consumidor debe comunicarse con el Comercio que usted realizó la compra de este producto y solicita asistencia técnica para las partes dañadas. La garantía cubre todas las partes, piezas y componentes que eventualmente puedan presentar defecto de fabricación en el plazo de 03 (tres) meses, contados a partir de la entrega del producto al consumidor, mediante factura de compra. Si se produce algún cambio en la estructura del producto o se produce un defecto por negligencia del montador/consumidor en relación con las instrucciones de montaje y manipulación, no se prestará asistencia técnica gratuita.

## NOTICE

To clean your furniture, use a dry or wet cloth, and do not use chemicals that may damage your product.

## ASSEMBLY SYSTEM

The products' assembly system works according to the increasing order of the indicated numbers. For example: 01, 02, 03, 04 ... to the end of the assembly.

## TECHNICAL ASSISTANCE

To request Technical Assistance, the consumer must contact the retailer from whom you purchased this product and request technical assistance for the damaged parts. The warranty covers all parts, parts and components that may eventually present a manufacturing defect within a period of 03 (three) months, counting from the delivery of the product to the consumer, by means of a purchase invoice. If there is any change in the structure of the product or defect occurs due to negligence of the assembler/consumer in relation to the assembly and handling instruction, free technical assistance will not be provided.

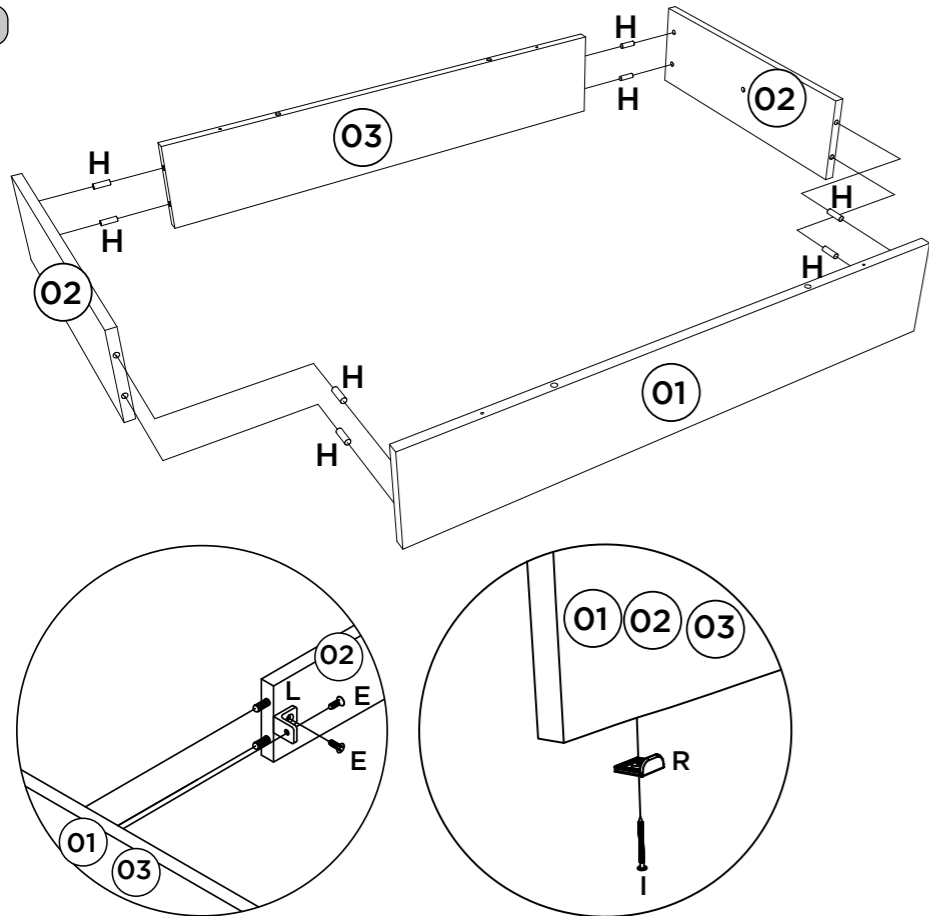

**OPCIONAL:**  
O945-121 Kit Pé Cônico 145mm (vendido separadamente). Caso opte em colocar pé no produto, utilizar as pré-furações que possui na Base e fixá-lo com o Parafuso que consta no Kit.

**OPCIONAL:**  
O945-121 Kit Pie Cónico 145mm (se vende por separado). Si opta por colocar pie en el producto, utilizar las pre-huracuras que tenga en la Base y fijarlo con el Tornillo que consta en el Kit.

**OPTIONAL:**  
O945-121 Tapered Foot Kit 145mm (sold separately). If you choose to put foot in the product, use the pre-drillings in the Base and fix it with the Screw included in the Kit.

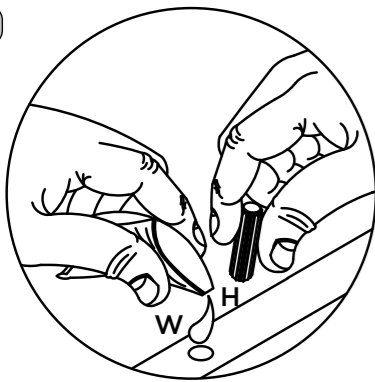

Utilizar o sachê de cola (W) em todas as cavilhas (H) do produto.

Con el pegamento sobre (W) en todos los pernos (H) producto.

Use the glue sachet (W) on all the pegs (H) of the product.

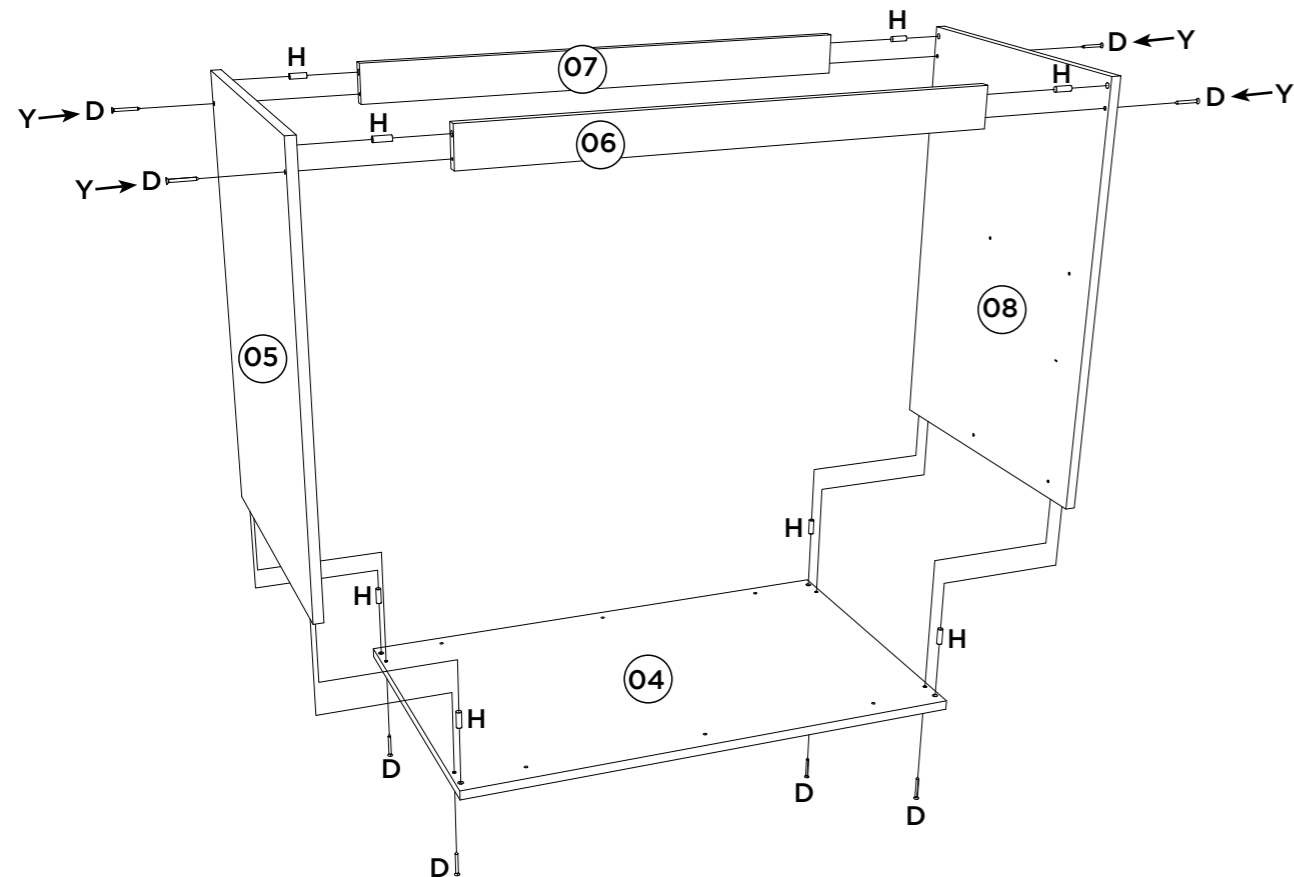

2x

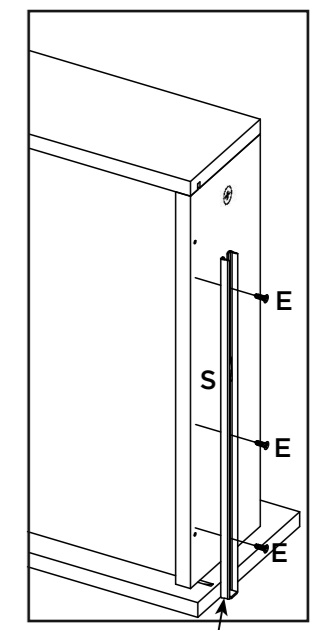
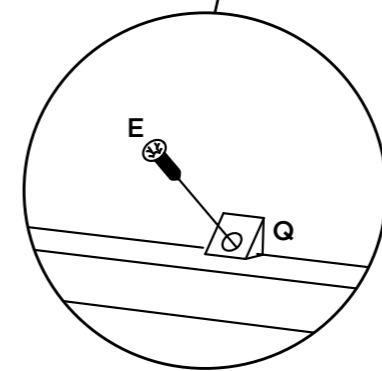
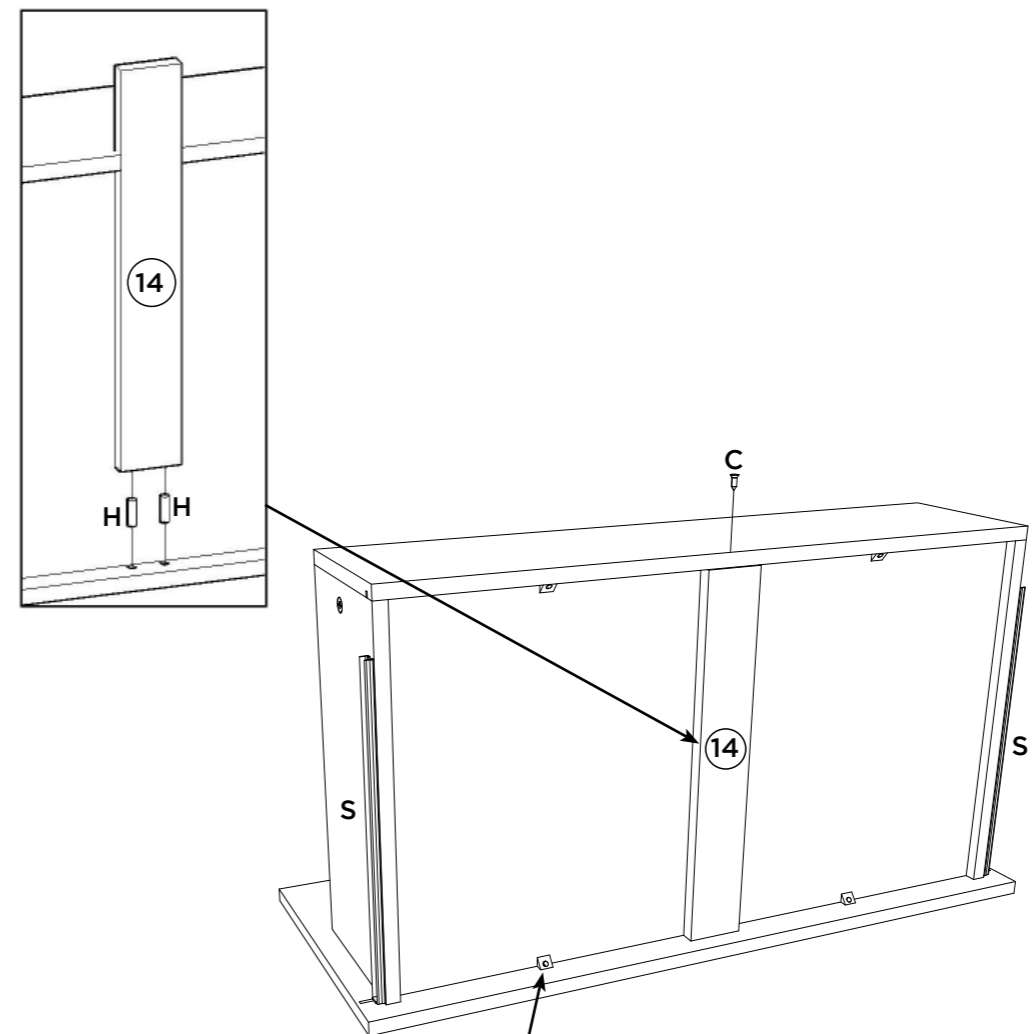

Deixar 3mm de distância da frente de gaveta.

Deje una separación de 3mm del frente del cajón.

Leave 3mm away from the front of the drawer.

2x



Vídeo: Dicas para fixar o Minifix

Video: Consejos para arreglar Minifix

Video: Tips for Fixing Minifix

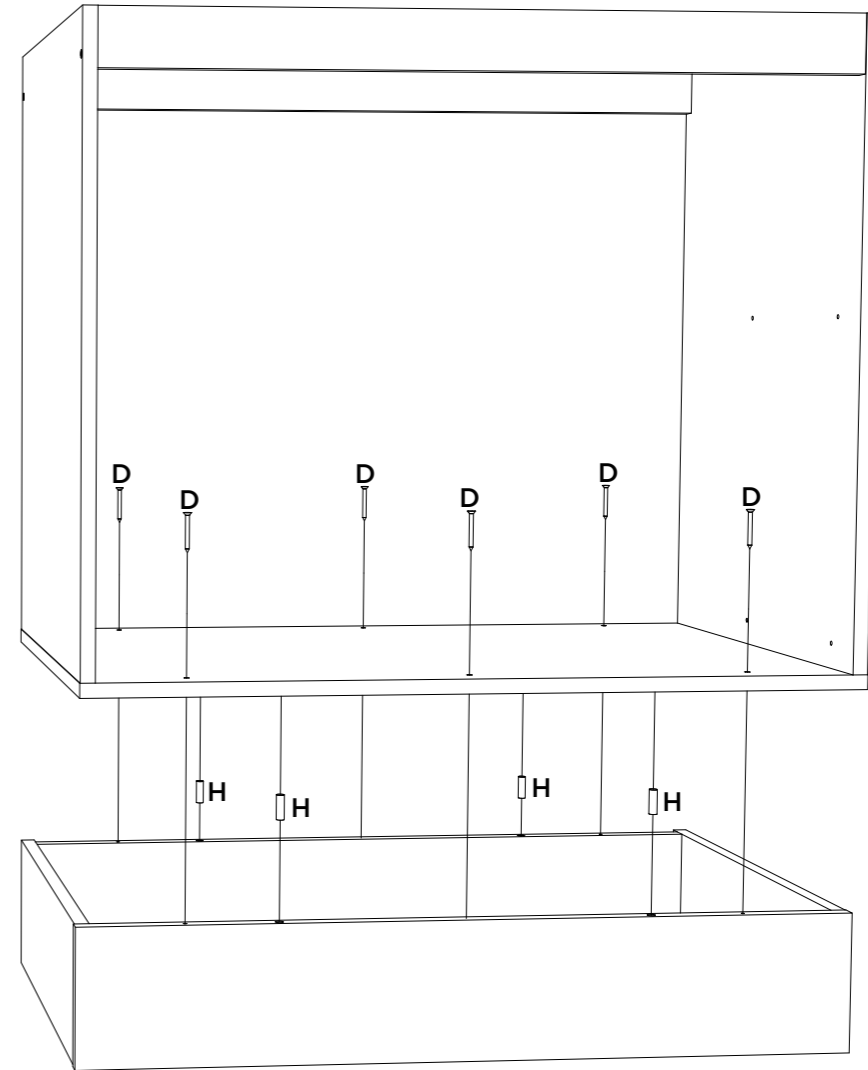
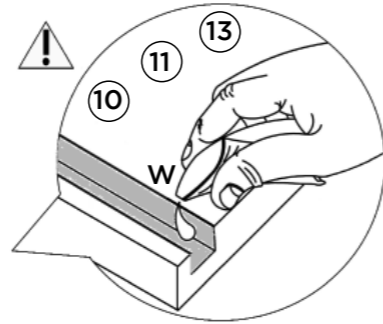
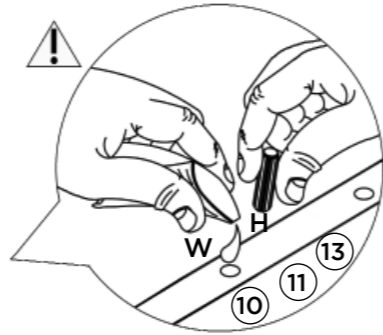
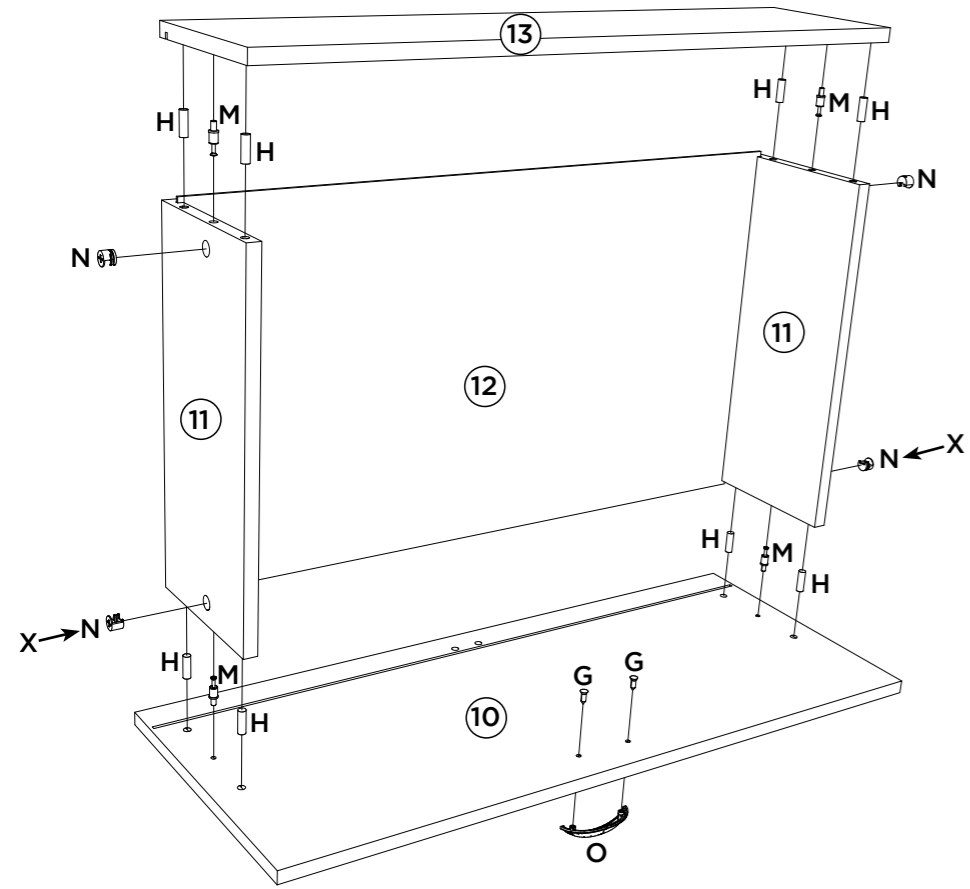

Esse tampo é opcional e é vendido separadamente (C904-114).

Esta vez es opcional y se vende por separado (C904-114).

This top is optional and is sold separately (C904-114).

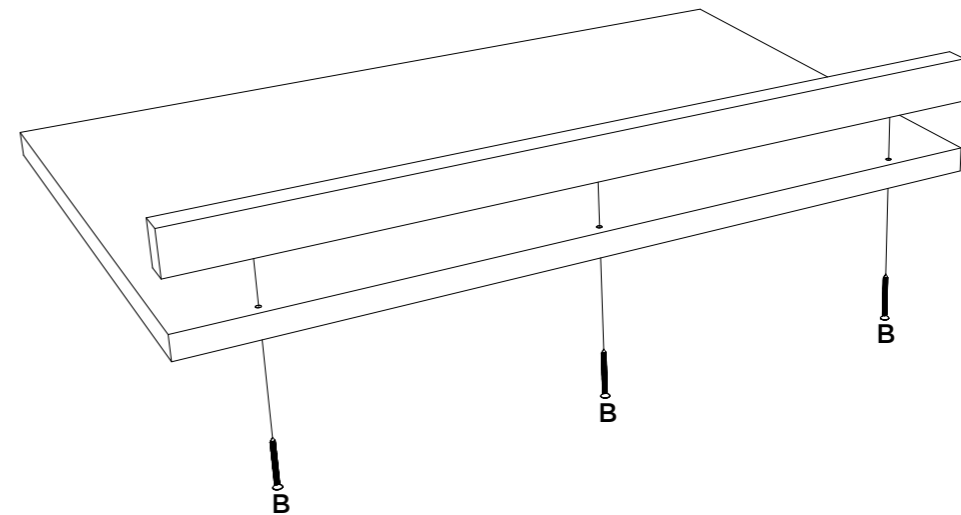

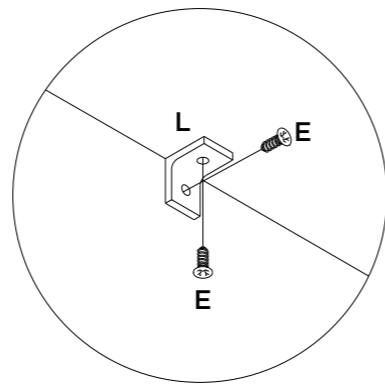
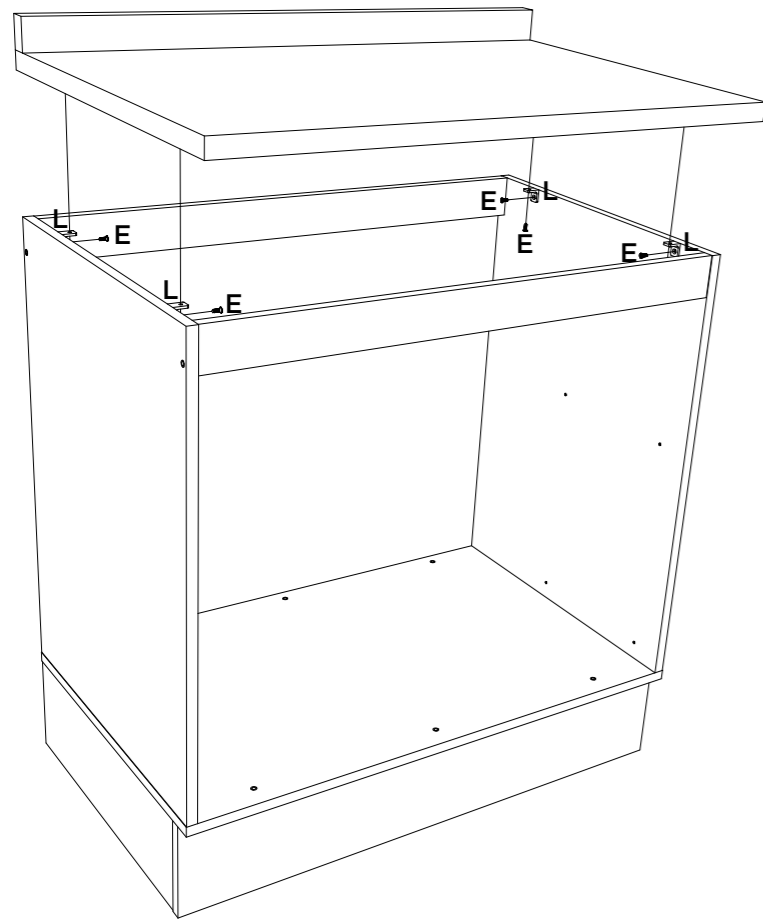

Caso o móvel seja montado com a opção do tampo, fixar o mesmo com 04 cantoneiras (L) e os parafusos 4,0x14mm (E).

Si se monta el auricular con la opción de la cubierta, fijarlo con Los ángulos 04 (L) y 4,0x14mm tornillos (E).

If the furniture is to be installed with the top cover option, fix it with 04 (L) and 4,0x14mm screws (E).

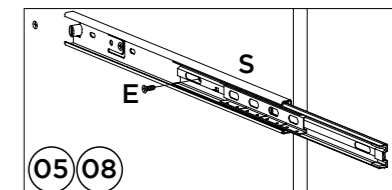
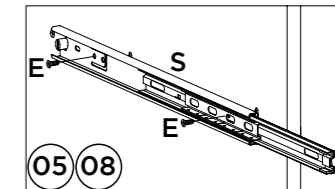
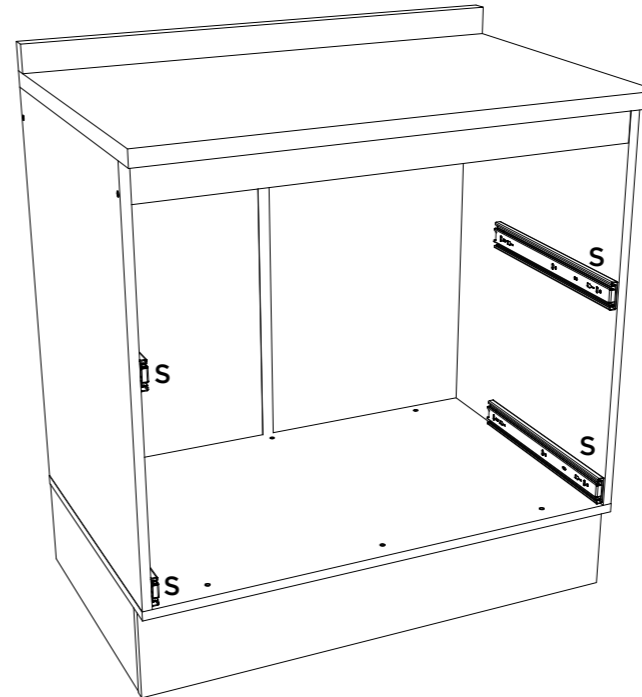

Vídeo: Dicas para fixar a Corrediça

Vídeo: Consejos para arreglar la diapositiva

Video: Tips for Fixing the Slide

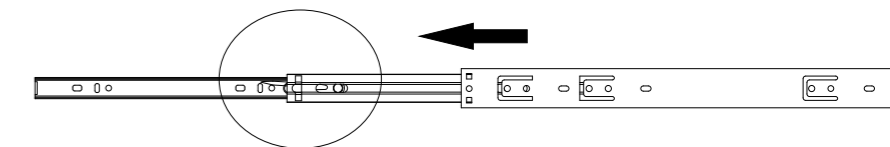

Para a desmontagem da corrediça siga a instrução ao lado.

Para el desmontaje seguimiento de diapositivas la instrucción siguiente a.

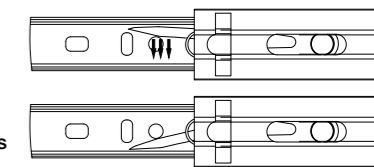

Fixar as corrediças nessas furações  
Fijar las diapositivas de estos agujeros

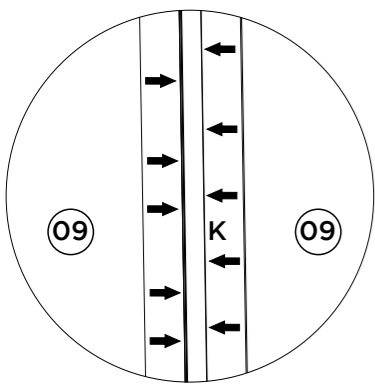
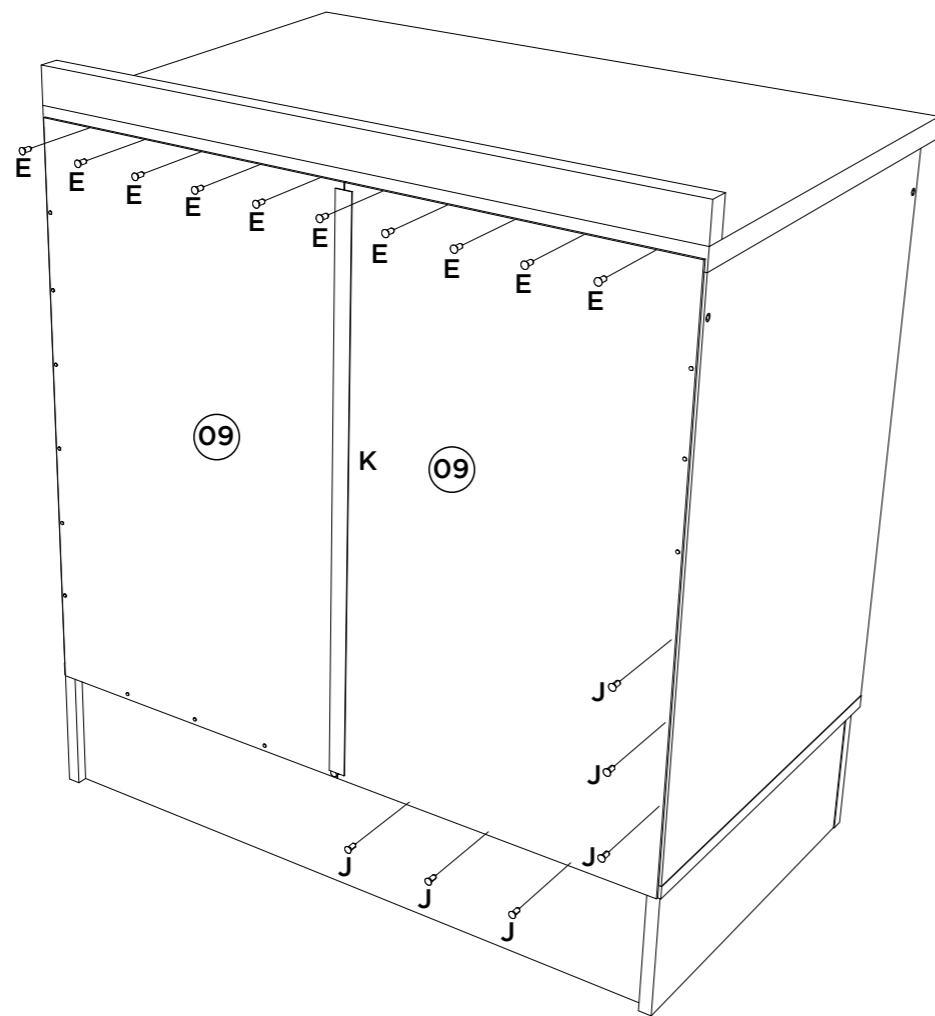

Opção Suspensa

Opción suspendida

Suspended Option

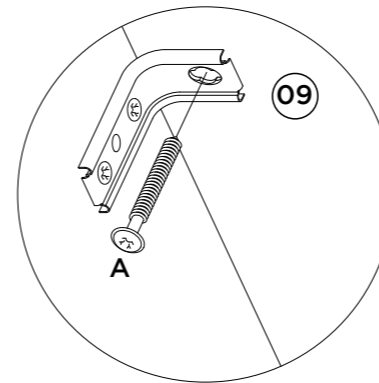
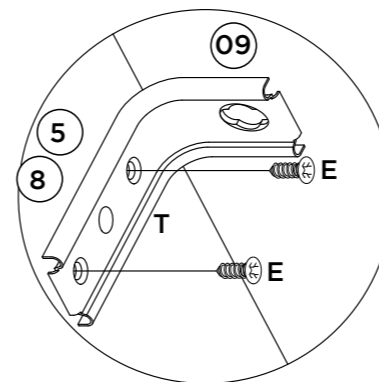

Parede  
pared  
Wall

