

# MANUAL DE MONTAGEM

## ATENÇÃO:

- 1 - Ler atentamente todo o manual antes de iniciar a montagem do móvel.
- 2 - A montagem deve ser feita em uma superfície plana e limpa.
- 3 - Recomenda-se utilizar a embalagem do móvel para forrar e chão e assim não danificá-los

## LIMPEZA E CONSERVAÇÃO:

A limpeza do móvel deve ser feita com utilização de pano umedecido com água, podendo conter uma pequena quantidade de álcool. Não utilize produtos abrasivos.

## GARANTIA:

90 dias para defeitos de fabricação.

Quantidade de pessoas  
necessárias para montar o  
móvel

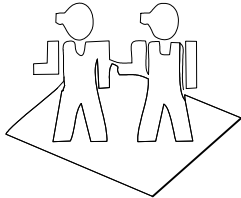







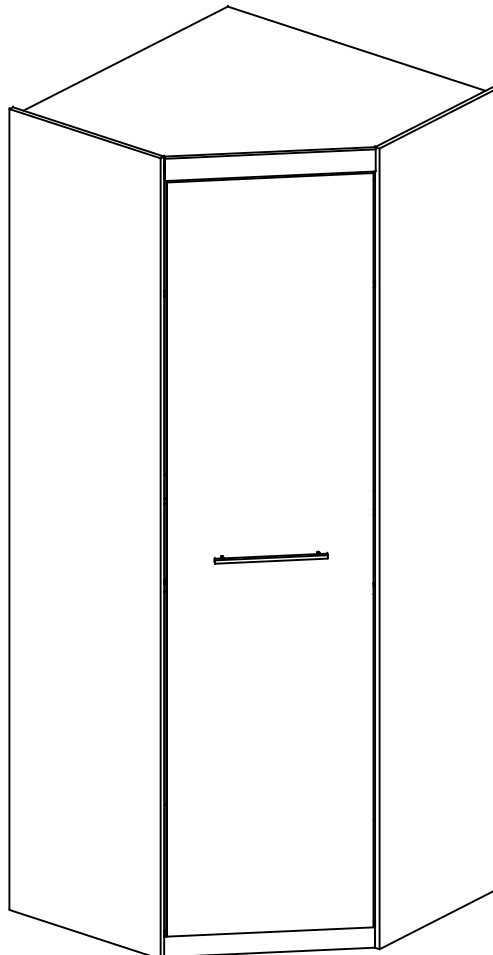
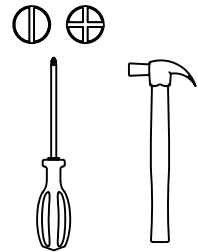



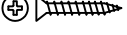
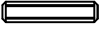

Tempo necessário para a  
montagem: 2h

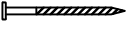









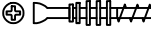

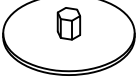
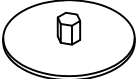

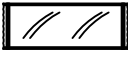

Ferramentas necessárias



Lista de peças						
Código de assistência	Descrição	Quant.	Compr. (mm)	Larg. (mm)	Espes. (mm)	Caixa/ volume
01	Porta	1	573	448	15	A
02	Lateral direita	1	573	448	15	A
03	Lateral esquerda	1	705	448	15	A
04	Pilastra maior	1	705	448	15	A
05	Travessa traseira	2	1012	448	15	B
06	Pilastra menor	1	1012	224	15	A
07	Chapéu	1	536	448	15	B
08	Base	1	536	448	15	B
09	Base do maleiro	1	505	448	15	B
10	Rodapé tras. maior	1	505	416	15	B
11	Rodapé tras. menor	1	505	352	15	B
12	Rodapé frontal maior	1	505	60	15	B
13	Rodapé frontal menor	2	505	60	15	B
14	Rodaforro	1	536	64	15	B
15	Costas	4	645	515	3	A
16	Costas do maleiro	2	515	130	3	B

Ferragem			
	Código de assistência	Descrição	Quant.
A	226	 Parafuso chato 4,0x40 bicromatizado	4
B	10571	 Parafuso maquina M4 X 42 cab. panela	2
C	4214	 Parafuso chato 3,5x14 cabeça rebaixada	92
D	491	 Parafuso chato 4,0x25 bicromatizado	4
E	1802	 Cavilha 6x30mm	19
F	107	 Prego 10 x 10	138
G	149	 Prego 13 x 15	9
H	899	 Cantoneira de metal	14
I	8578	 "L" de Zamaq 13x13	2
J	85	 "L" de metal	10
K	10276	 Puxador de metal cromado 300mm	1
L	1901	 Sapata deslizadora preta	9
M	58	 Etiqueta marca "Kappesberg"	1
N	8010	 Tapa furo adesivo 13mm BR= Branco liso	4
N	40736	 Tapa furo adesivo 13mm NO= Nogal	4

O	1423	 Fixador de costa	16
P	30945	 Minifix (parafuso)	12
Q	30950	 Minifix (tambor)	12
R	2347	 Tampa para minifix BR=Branco	12
R	14855	 Tampa para minifix NO= Caravalle	12
S	15021	 Dobradiça 45° 35	3
T	15021	 Calço para dobradiça	3
U	15021	 Parafuso panela 4,0x14 para dobradiça	12
V	41	 Cola branca em bisnaga (10g)	1
W	10307	 Par de afastador de nylon crom 20mm	1
X	10306	 Par de ponteira crom 10x10	1
Z	12300	 Perfil "H" 1840mm BR= Branco	2
Z	16346	 Perfil "H" 1840mm NO=Carvalle	2
AA	16415	 Suporte para cabideiro J de metal	1
AB	16362	 Apoio roliço	1
AC	16323	 Roliço oblongo canto 90° 649 x 649	2
AD	1446	 Suporte para cabideiro oblongo plástico	4
1 Saco grande para parafusos e dobradiça			



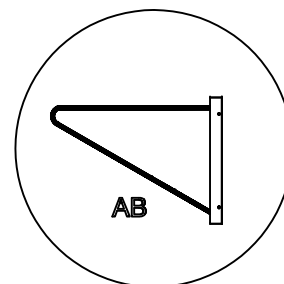
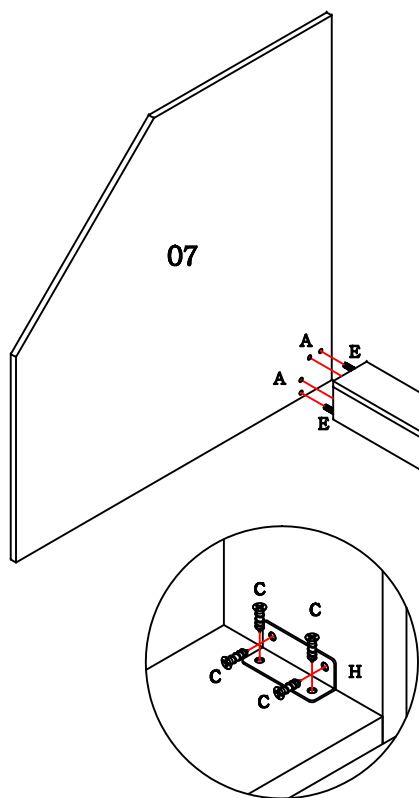
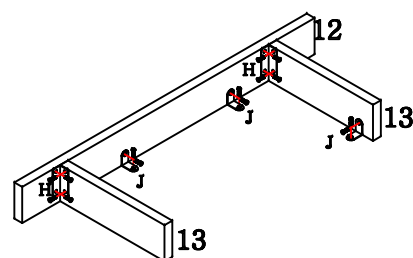
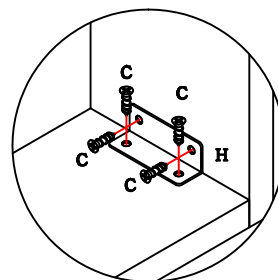
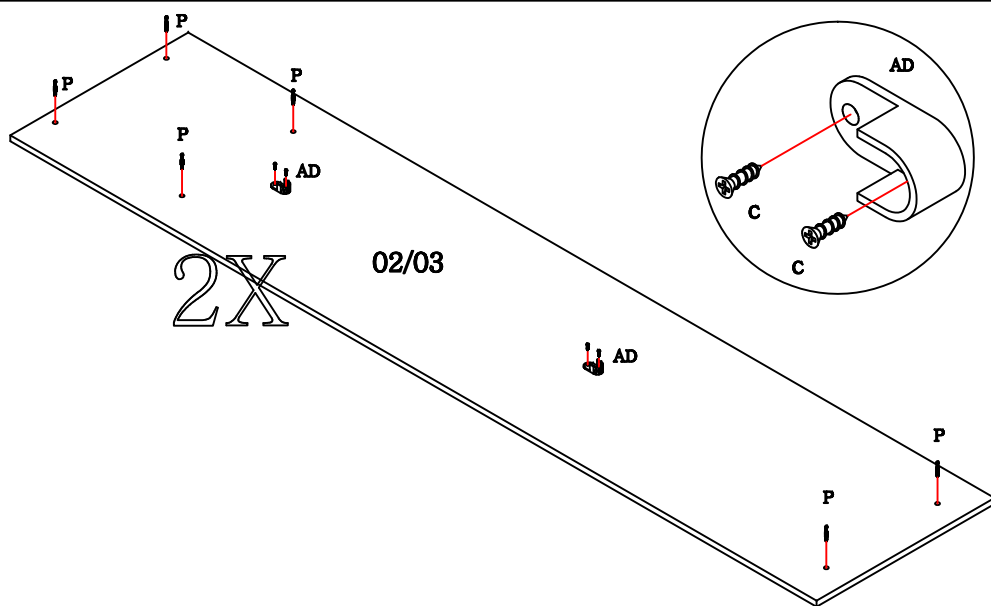

Utilize o parafuso "C" para fixar o apoio para roliço "AB".

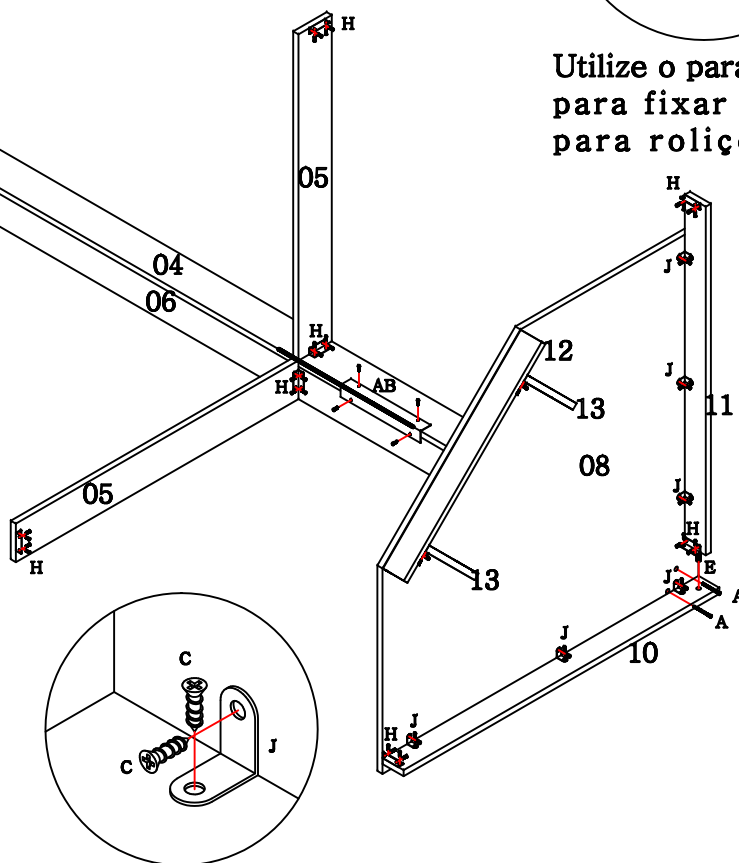

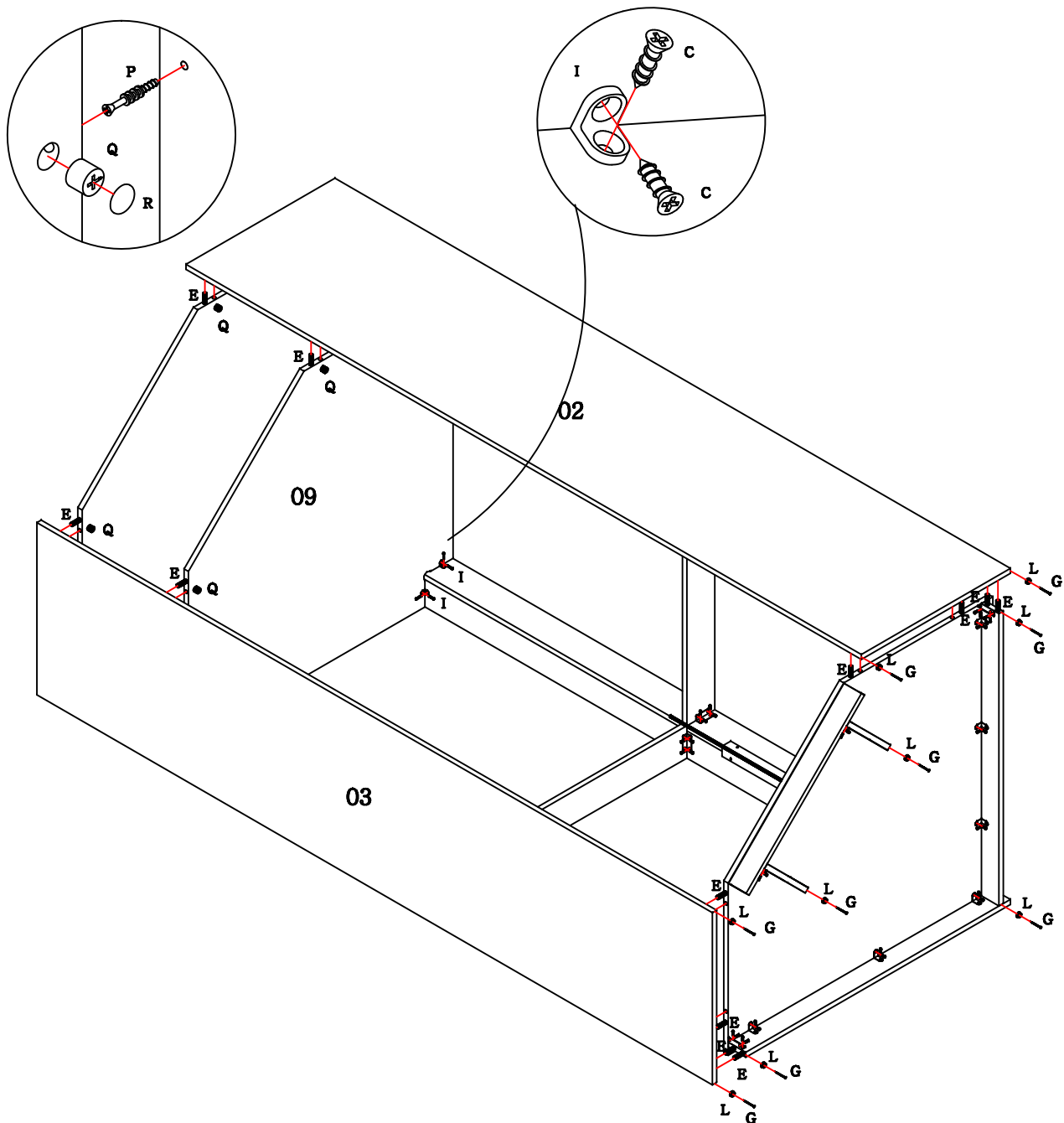

Utilize o suporte J de metal "AA", para dar suporte ao roliço oblongo "AC", fixe com o parafuso "C" na base do maleiro "09".

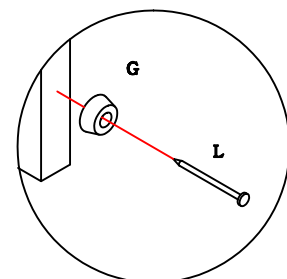

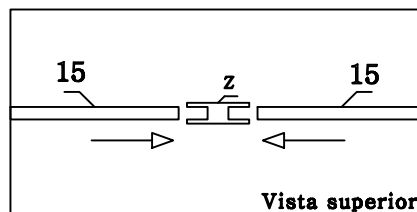
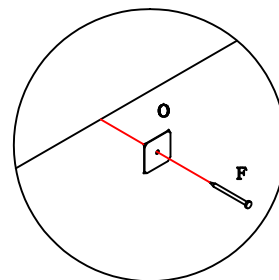
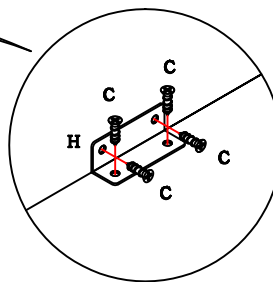
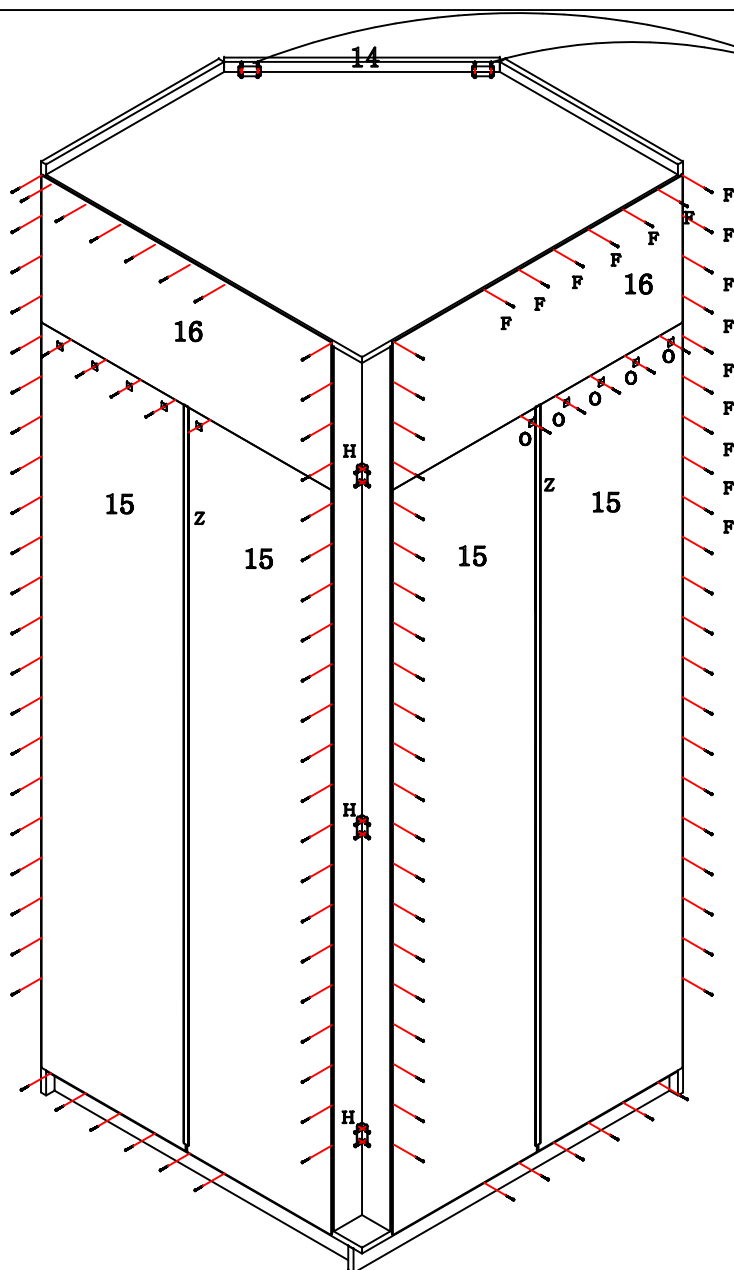

Utilize o parafuso "D" para  
fixar um módulo em outro.

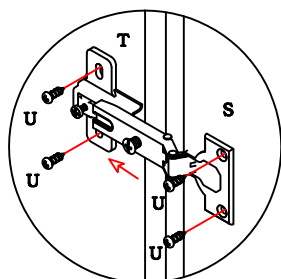

A dobradiça "S" deve ser  
encaixada no calço "T" e  
estes colocados com os  
parafusos "U", observando  
o procedimento a cima.

