

2045 GABINETE BANHEIRO

2045 BATHROOM CABINET

2045 GABINETE BAÑO

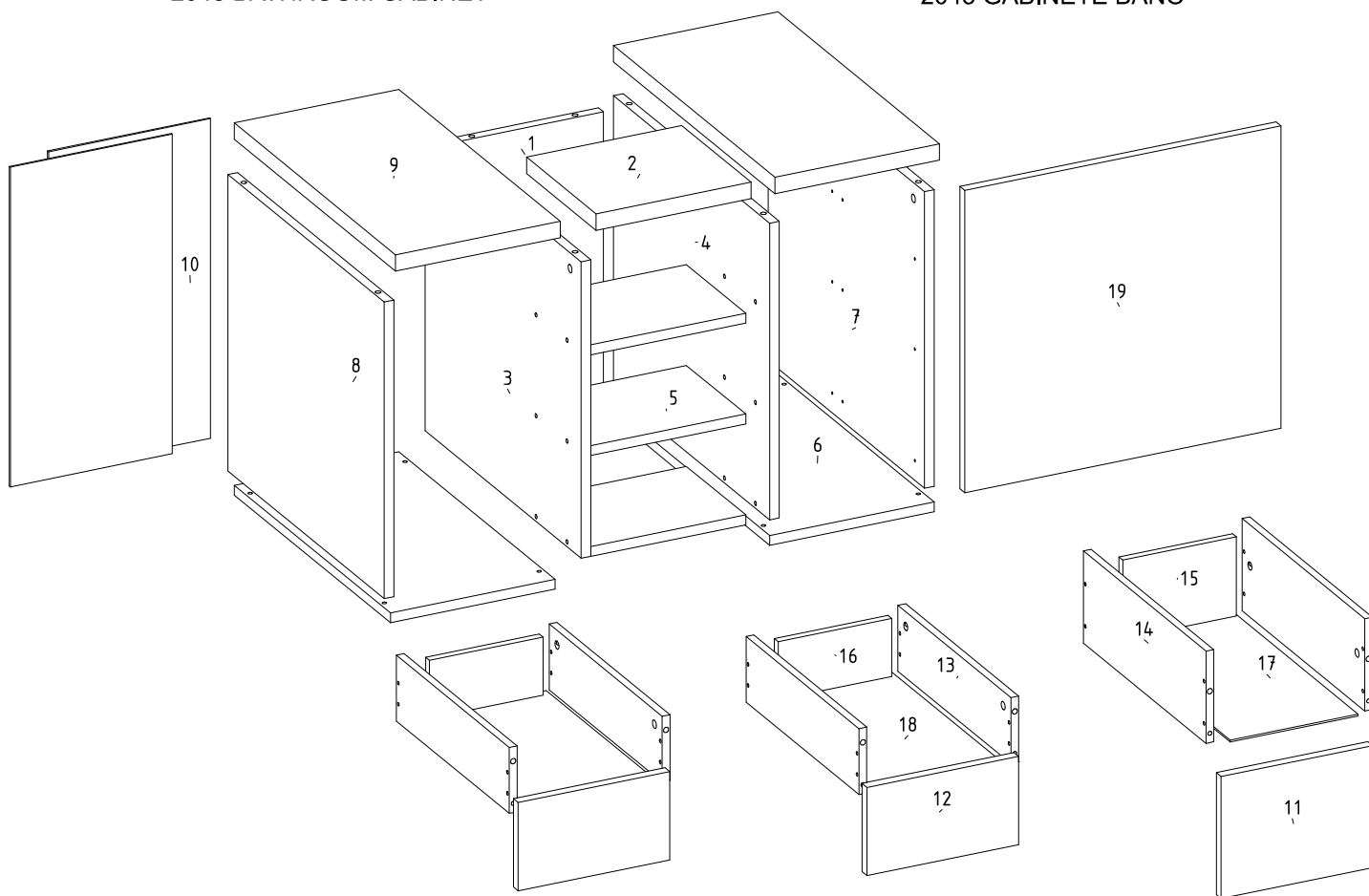

LISTA DE PEÇAS / Pieces List / Lista de Piezas

SEQ.	REF.	DESCRIÇÃO	DESCRIPTION	DESCRIPCIÓN	MAT.PRIMA	COMP.	LARG.	ESP.	QTD.
1	7841	PAINEL TRASEIRO	REAR PANEL	PANEL TRASERO	MDP	450	240	15	1
2	7842	TAMPO CENTRAL	CENTRAL TAP	TAMPO CENTRAL	MDP	240	215	25	1
3	7843	DIVISORIA ESQUERDA	LEFT DIVISION	DIVISORIA ESQUERDA	MDP	450	484	15	1
4	7844	DIVISORIA DIREITA	RIGHT DIVISION	DIVISORIA DIREITA	MDP	484	450	15	1
5	7845	PRATELEIRA	SHELF	PRATELEIRA	MDP	240	184	15	3
6	7846	BASE	BASE	BASE	MDP	484	255	15	2
7	7847	LATERAL DIREITA	RIGHT SIDE	LATERAL DERECHO	MDP	450	484	15	1
8	7848	LATERAL ESQUERDA	LEFT SIDE	LATERAL IZQUIERDO	MDP	450	484	15	1
9	7849	TAMPO	TOP	TAMPO	MDP	500	255	25	2
10	7850	FUNDO	BACKGROUND	FONDO	HDF	251	485	3	2
11	7851	FRENTE GAVETA MAIOR	DRAWER FRONT	FRENTE DE GAVETA	MDP	235	185	15	1
12	7852	FRENTE GAVETA MENOR	DRAWER FRONT	FRENTE DE GAVETA	MDP	235	134	15	2
13	7853	LATERAL GAVETA MENOR	DRAWER SIDE	LATERAL DE GAVETA	MDP	350	100	12	4
14	7854	LATERAL GAVETA MAIOR	DRAWER SIDE	LATERAL DE GAVETA	MDP	380	140	12	2
15	7855	CONTRA FUNDO MAIOR	AGAINST FUND	CONTRA FONDO	MDP	176	120	12	1
16	7856	CONTRA FUNDO MENOR	AGAINST FUND	CONTRA FONDO	MDP	176	88	12	2
17	7857	FUNDO DE GAVETA MAIOR	DRAWER BACKGROUND	FONDO GAVETA	HDF	198	385	3	1
18	7858	FUNDO DE GAVETA MENOR	DRAWER BACKGROUND	FONDO GAVETA	HDF	198	355	3	2
19	7859	PORTA	DOOR	PUERTA	MDF	490	459	15	1

Data de lançamento: 29/08/2017
Versão:

Data de Atualização: 11/09/2017
Revisão: -

DETALHAMENTO
DETAL / DETALLES

DETALHAMENTO
DETAL / DETALLES

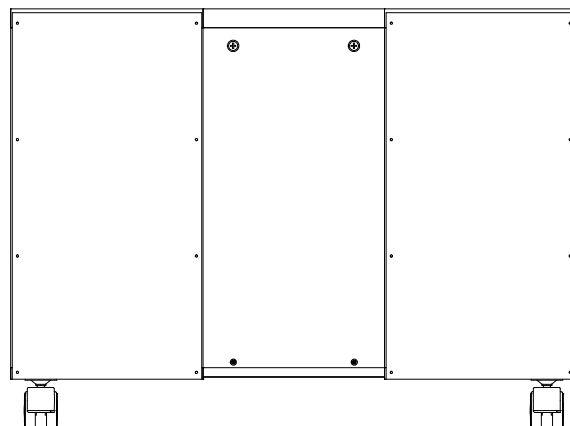
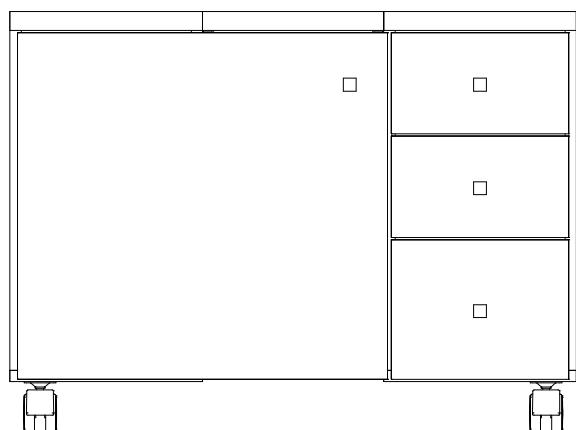

INSTRUÇÃO MONTAGEM PRODUTO

Intructions to Assembly / Instrucciones de montaje



Separar as peças e acessórios de maneira organizada
Separate parts and accessories in way organized
Separar las piezas y accesorios de manera organizada



Forrar o chão com o papelão das embalagens.
Cover the floor with the cardboard
Cubra el suelo con la embalaje de cartón



É necessário 01 pessoa para montar o produto
It is necessary one person to assembly
Es necesario una persona para ensamblar

O produto deve ser a montado por um profissional qualificado
The product must be assembly by a professional
El producto debe ser ensamblado por un profesional calificado

Ferramentas necessárias
(não fornecidas)
Not include tools / No herramientas



CUIDADO PARA CONSERVAÇÃO E LIMPEZA DO MÓVEL

Care to conservation and clean / Cuidados de limpieza



O peso máximo de carga informado refere-se a objetos distribuido de maneira uniforme sobre toda área de contato da peça
Set maximum weight load refers to objects distributed uniformly over the entire contact area of the workpiece.
Conjunto de carga máxima de peso se refere a objetos distribuidos uniformemente sobre toda el área de contacto de la pieza de trabajo.



Não molhar o móvel e não expor em lugar úmido
Do not wet the mobile and do not expose in a wet place
No moje el producto y no exponer en un lugar húmedo



Não expor o móvel próximo de fontes de calor.
Do not expose the mobile near heat sources
no esponga cercano de fuentes de calor



Não usar produtos abrasivos.
Do not use abrasive products.
No utilice productos abrasivos.



Limpe com flanela limpa e seca.
Clean with dry cloth
Limpieza con un paño limpio y seco

LISTA DE ACESSÓRIOS E FERRAGEM / ACCESSORIES AND HARDWARE / ACCESORIOS Y EQUIPOS



A 589 PARAFUSO 4.5 X 45 CHATA PHILIPS 20 UNID
Screw 4.5 X 45 / Tornillo 4.5 X 45

B 580 PARAFUSO 3.5 X 12 CHATA PHILIPS 28 UNID
Screw 3.5 X 25 / Tornillo 3.5 X 25

C 574 PARAFUSO MINIFIX ZAMAC 33 MM 16 UNID
Minifix screw 33 mm / Tornillo minifix 33 mm

D 755 CANTONEIRA GAVETA 02 UNID
Corner drawer / Cantonera cajón

E 582 PARAFUSO 3.5 X 25 CHATA PHILIPS 18 UNID
Screw 3.5 X 25 / Tornillo 3.5 X 25

F 579 PARAFUSO 3 X 12 CHATA PHILIPS 48 UNID
Screw 3.0 X 12 / Tornillo 3.0 X 12

G 595 CORREDICA METALICA 300 MM 03 UNID
Corredica Metalica / orredica Metalica

H 753 CAVILHA MADEIRA 6 X 30 MM 06 UNID
Wood Bolts / Cuchillo de madera

I 575 TAMBOR MINIFIX Ø12 X 11 MM 16 UNID
Minifix Drum / Tambor Minifix

J 602 DOBRADICA 26 MM RETA 02 UNID
Hinge / dobradica

K 7815 PUXADOR VARESE 04 UNID
Handle Varese / Tirador Varese

L 576 PREGO 10X10 COM CABECA 37 UNID
Nail/ Clavo

M 600 CALCO DOBRADICA 5 MM 02 UNID
Stick hinge/ Calco Dobradica

N RODIZIO CHAPA RETA 50MM 04 UNID
Rodizio Straight Sheet / Rodizio Chapa Reta

O TAPA FURO GIROFIX 16 UNID
Girofix Hole Cover / Tapa Furo Girofix

P 0591 SACHE DE COLA 01 UNID
Tail Sache/Sache de cola

Data de lançamento: 29/08/2017
Versao:

Data de Atualização: 11/09/2017
Revisão: -

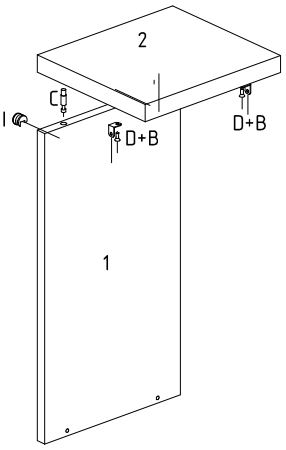
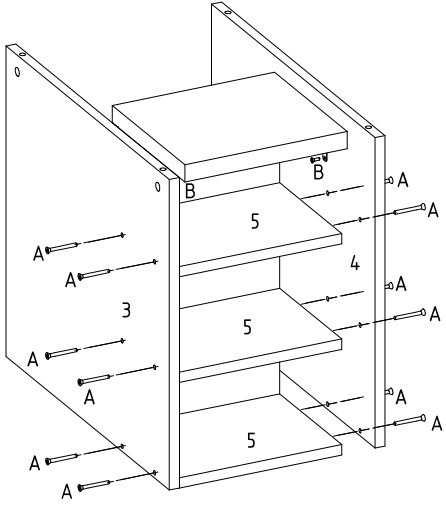
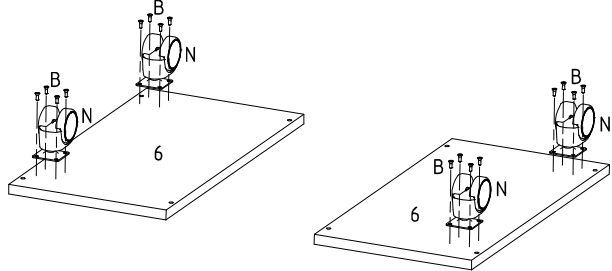
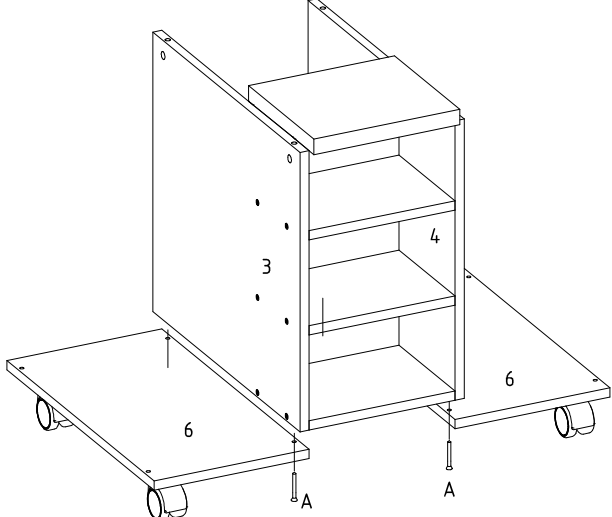
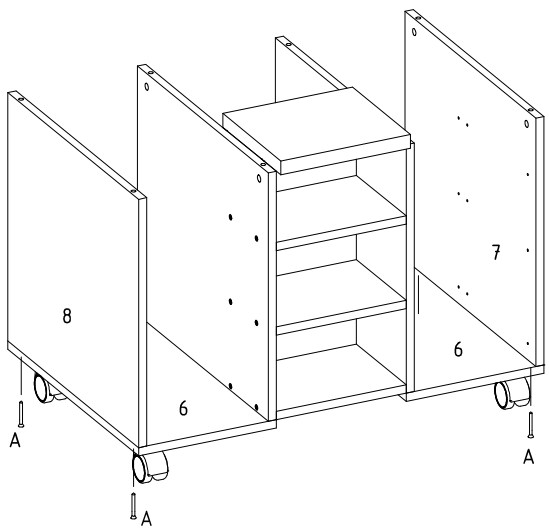
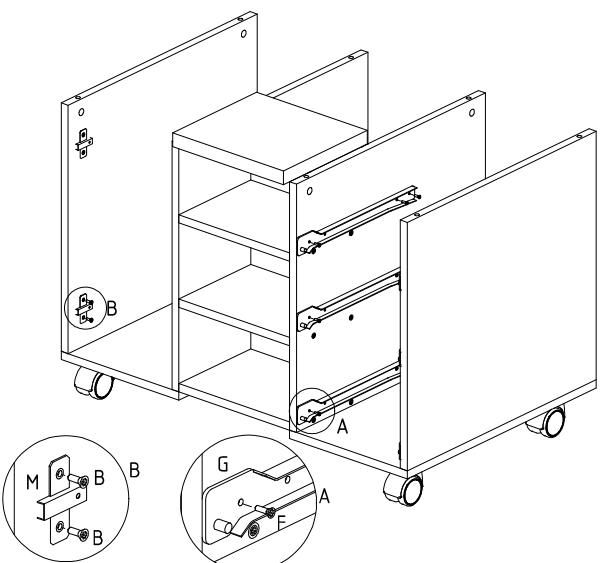
<p>01° PASSO</p> <p>01° STEP</p> <p>01° PASO</p> <p>C</p> <p>I</p> <p>D</p> <p>B</p> <p>-</p> <p>-</p> <p>-</p>	<p>Fixar a peça 01 na peça 02</p> <p>Fasten part 01 to part 02</p> <p>Fijar la pieza 01 en la peça 02</p> 	<p>02° PASSO</p> <p>02° STEP</p> <p>02° PASO</p> <p>A</p> <p>B</p> <p>-</p> <p>-</p> <p>-</p> <p>-</p> <p>-</p>	<p>Fixar as peças 05 nas peças 03 e 04</p> <p>Fasten parts 05 to parts 03 and 04</p> <p>Fijar las piezas 05 en las piezas 03 y 04</p> 
<p>03° PASSO</p> <p>03° STEP</p> <p>03° PASO</p> <p>B</p> <p>N</p> <p>-</p> <p>-</p> <p>-</p> <p>-</p>	<p>Fixar os Rodizios na peça 06</p> <p>Attach the Rods in part 06</p> <p>Fijar los Rodillos en la pieza 06</p> 	<p>04° PASSO</p> <p>04° STEP</p> <p>04° PASO</p> <p>A</p> <p>-</p> <p>-</p> <p>-</p> <p>-</p> <p>-</p>	<p>Fixar as peças 06 nas peças 03 e 04</p> <p>Fixar as peças 06 nas peças 03 e 04</p> <p>Fijar las piezas 06 en las piezas 03 y 04</p> 
<p>05° PASSO</p> <p>05° STEP</p> <p>05° PASO</p> <p>A</p> <p>-</p> <p>-</p> <p>-</p> <p>-</p> <p>-</p>	<p>Fixar as peças 07 e 08 nas peças 06</p> <p>Fix parts 07 and 08 on parts 06</p> <p>Fijar las piezas 07 y 08 en las piezas 06</p> 	<p>06° PASSO</p> <p>06° STEP</p> <p>06° PASO</p> <p>B</p> <p>F</p> <p>G</p> <p>M</p> <p>-</p> <p>-</p> <p>-</p>	<p>Fixar as corrediças e os Calços de Dobradiça.</p> <p>Fasten the slides and the Hinge Pads.</p> <p>Fijar las diapositivas y los calzos de bisagra.</p> 

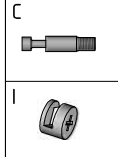
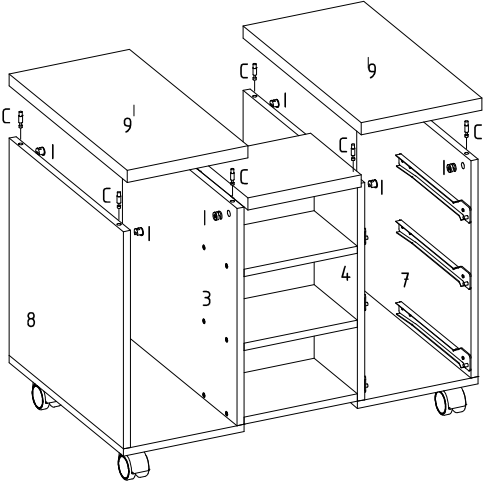
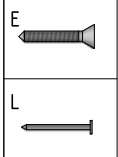
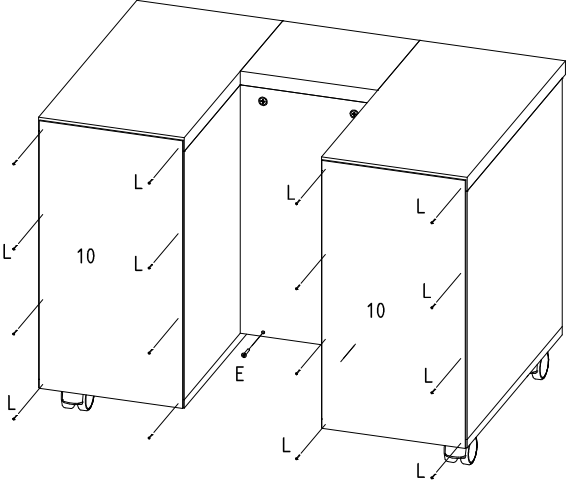
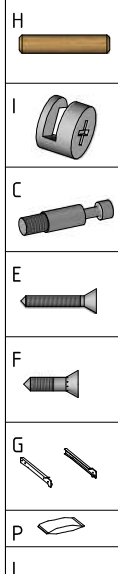
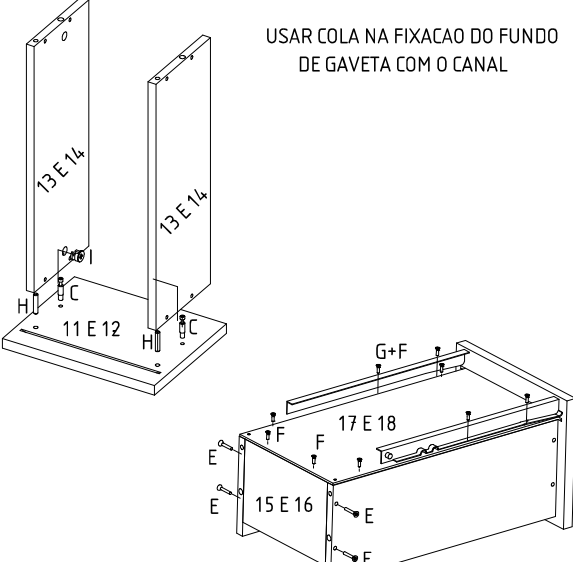
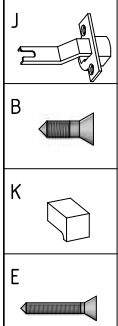
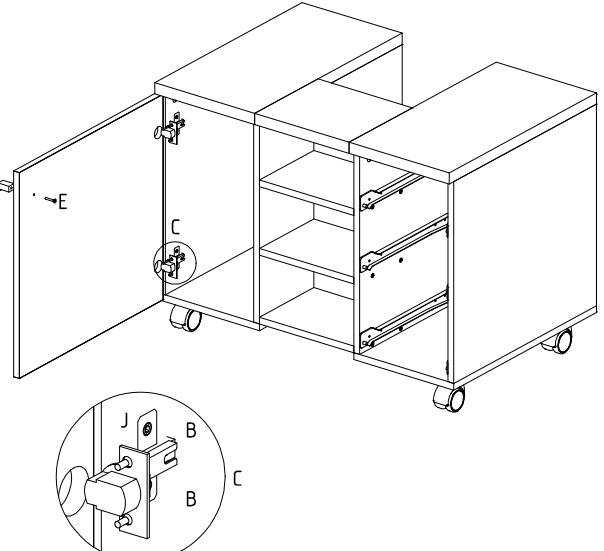
07° PASSO	Fixar as peças 09 nas peças 03,04,07 e 08	08° PASSO	Pregar os fundos no móvel.
07° STEP	Fix parts 09 on parts 03,04,07 and 08	08° STEP	Preach the funds on the mobile.
07° PASO	Fijar las piezas 09 en las piezas 03,04,07 y 08	08° PASO	Predicción de los fondos en el móvil.
			
09° PASSO	Montar as gavetas	10° PASSO	Fixar a Porta 19 na peça 08
09° STEP	Assemble the drawers	10° STEP	Attach Door 19 in part 08
09° PASO	Montar los cajones	10° PASO	Fijar la puerta 19 en la pieza 08
			
11° PASSO	Encaixar a Gaveta no Móvel.	12° PASSO	Aspecto Final do Produto
11° STEP	Attach the Drawer to the Mobile.	12° STEP	Final Product Appearance
11° PASO	Encaje la Cajón en el móvil.	12° PASO	Aspecto Final del Producto
