

## Capacidade de Carga - Load Capacity - Capacidad de carga

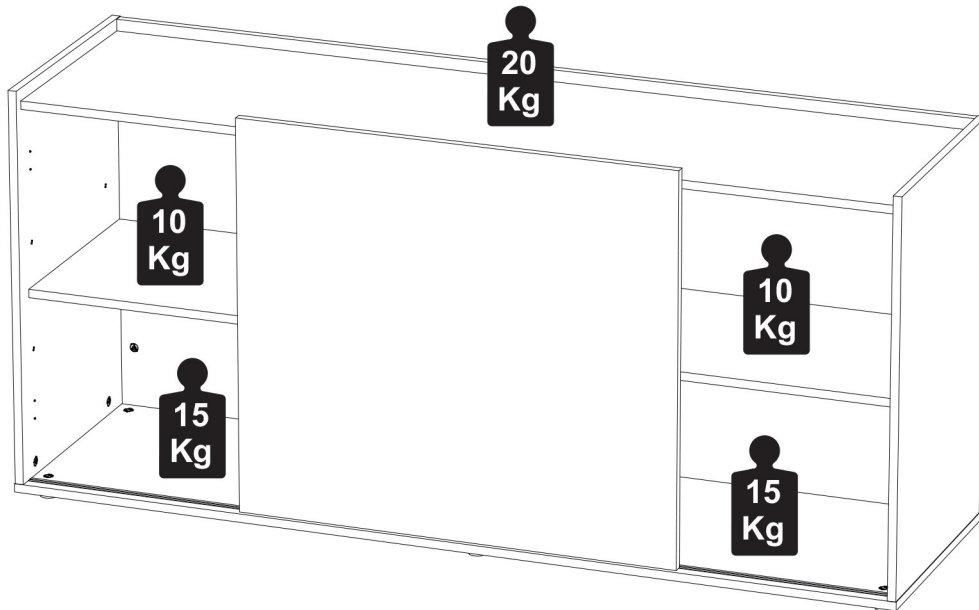

### Manutenção e Limpeza

Vidros: pano levemente umedecido com álcool, seguido de pano seco.  
Madeiras: pano levemente umedecido com água, seguido de pano seco.  
\*Nunca utilizar produtos químicos ou abrasivos.

### Maintenance and Cleaning

Glasses: cloth lightly moistened with alcohol, followed by dry cloth.  
Woods: cloth slightly moistened with water, followed by cloth seco.  
\*Never use chemicals or abrasives.

### Mantenimiento y Limpieza

Vidrios: legeramente humedecido con alcohol, seguido de un paño seco.  
Madera: ligeramente humedecido con agua, seguido de un paño seco.  
\*No utilice nunca productos quimicos o abrasivos.

## INSTRUÇÕES DE MONTAGEM ASSEMBLY INSTRUCTIONS INSTRUCCIONES DE MONTAJE

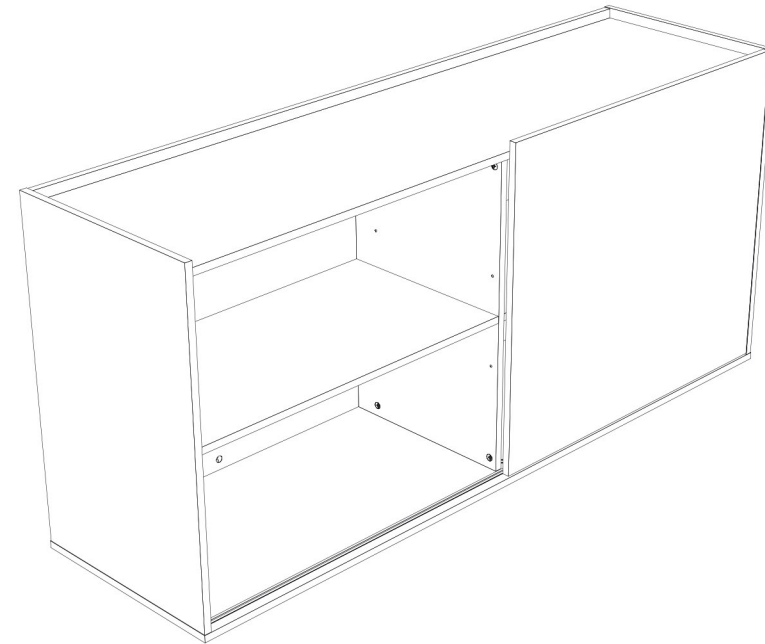

REF. # VRA1674



# Office

MÓVEIS CORPORATIVOS

São necessários:  
Son necesarios:  
Are necessary:



\*Parafusadeira  
Atornillador  
Screwdriver



\*Martelo  
Martillo  
Hammer



Chave Cruzada  
Llave cruzada  
Cross wrench



\*\*Trena  
Cinta métrica  
Measuring tape



90min



1 Pessoa  
Persona  
Person

\*Facilita a montagem / Facilita un montaje / Facilitates mounting.  
\*\* Para identificar as peças / Para identificar las partes / To identify the parts.

# LISTA DE PEÇAS

Parts Identification

Lista de Piezas

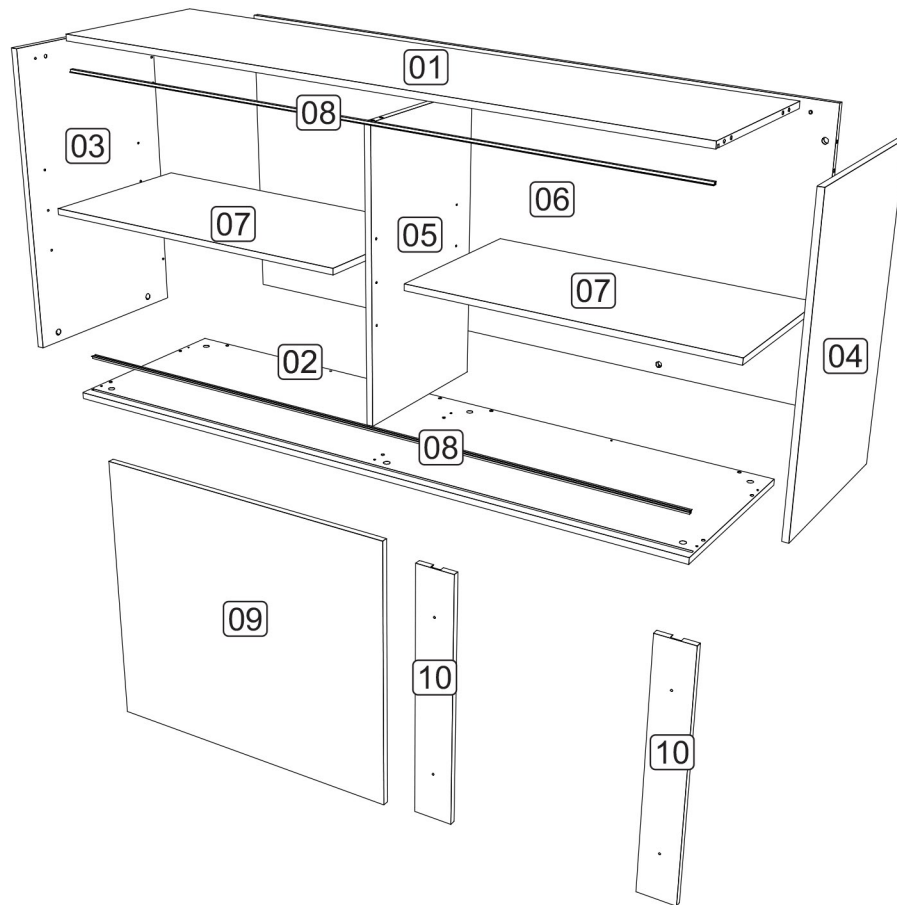

## LISTA DE PEÇAS

- 01 - TAMPO
- 02 - BASE
- 03 - LATERAL ESQUERDA
- 04 - LATERAL DIREITA
- 05 - DIVISÃO
- 06 - COSTA
- 07 - PRATELEIRA
- 08 - TRILHO
- 09 - PORTA
- 10 - TRAVESSA

## LISTA DE PIEZAS

- 01 - TABLERO DE MESA
- 02 - BASE
- 03 - LATERAL IZQUIERDO
- 04 - LADO DERECHO
- 05 - DIVISIÓN
- 06 - COSTA
- 07 - ESTANTE
- 08 - PISTA
- 09 - PUERTA
- 10 - BALLESTA

## PARTS IDENTIFICATION

- 01 - TOP
- 02 - BASE
- 03 - LEFT SIDE
- 04 - RIGHT SIDE
- 05 - DIVISION
- 06 - BACK
- 07 - SHELF
- 08 - RAIL
- 09 - DOOR
- 10 - CROSSBOW

# Acessórios

Accessories

Accesorios

D1 - CAVILHA 8x30

24x

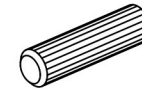

B1 - SUPORTE PRAT. METÁLICO 8x



F1 - TAPA FURO ø18

26x



A32 - PARAF. MINIFIX

20x

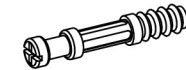

A35 - TAMBOR MINIFIX

20x



L4 - DESLIZADOR P/ARMÁRIO

6x

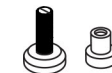

G9 - KIT PARA PORTA DE CORRER (01 PORTA)

1x

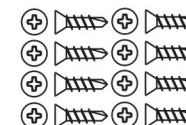
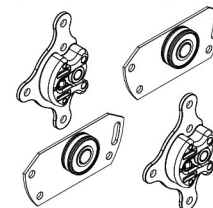

A4 - PARAF. 3,5x25 CC

4x

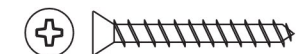

# PRÉ-MONTAGEM

Preasamblea

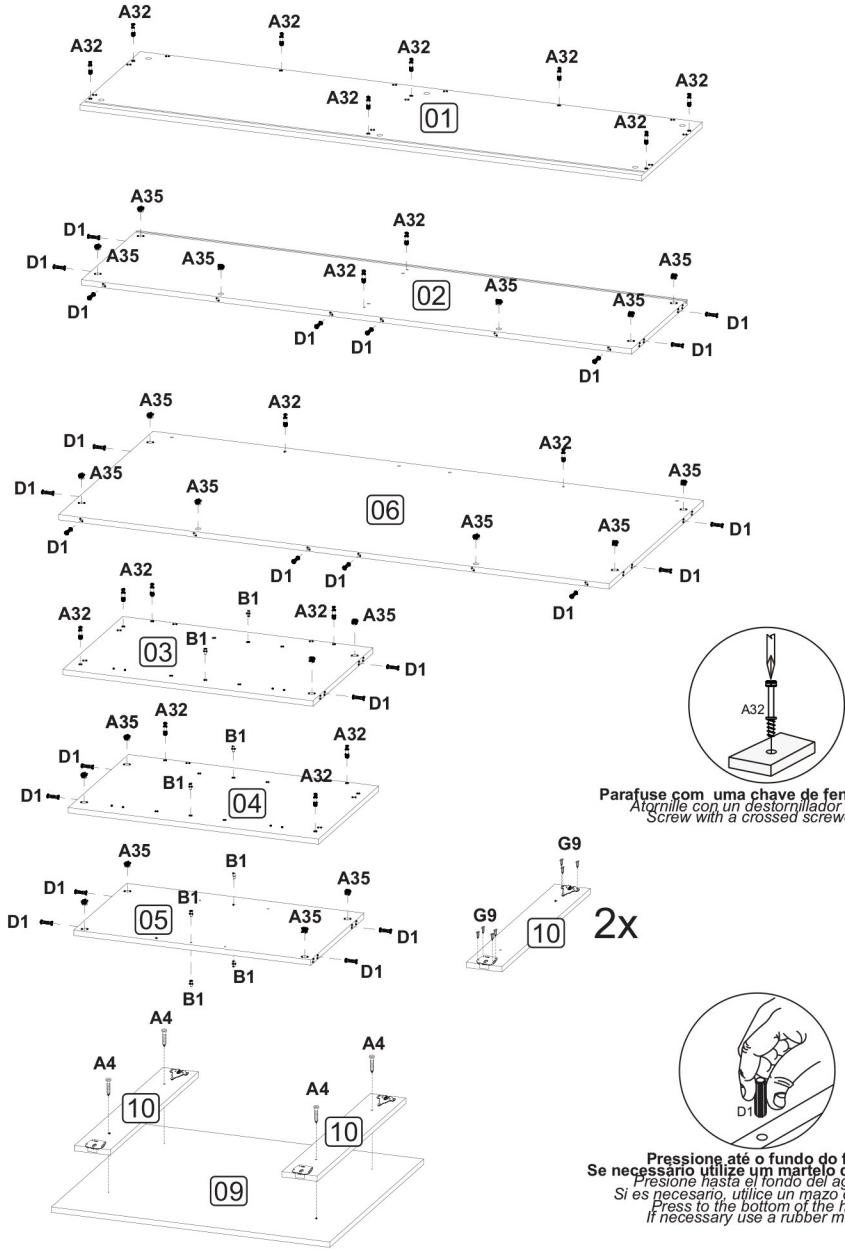

Parafuse com uma chave de fenda cruzada.  
Atornille con un destornillador cruzado.  
Screw with a crossed screwdriver.

Pressione até o fundo do furo.  
Se necessário utilize um martelo de borracha.  
Presione hasta el fondo del agujero.  
Si es necesario, utilice un mazo de goma.  
Press to the bottom of the hole.  
If necessary use a rubber mallet.

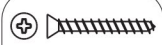

A4 - 4x



A35 - 20x



B1 - 08x



A2 - 1x

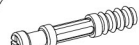

A32 - 20x



D1 - 24x

# 1

## MONTAGEM

Armado  
Assembly

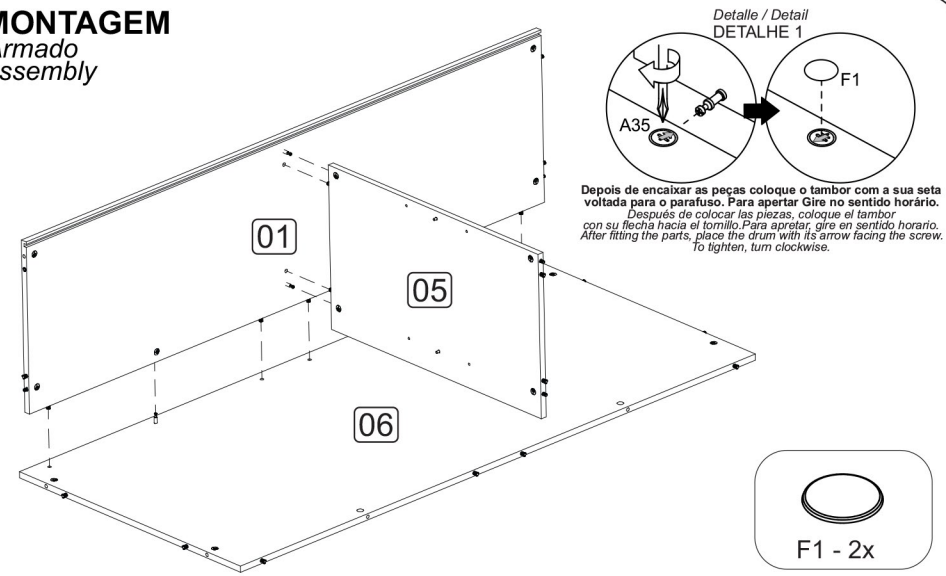

Depois de encaixar as peças coloque o tambor com a sua seta voltada para o parafuso. Para apertar Gire no sentido horário.  
Después de colocar las piezas, coloque el tambor con su flecha hacia el tornillo. Para apretar, gire en sentido horario.  
After fitting the parts, place the drum with its arrow facing the screw.  
To tighten, turn clockwise.



F1 - 2x

# 2

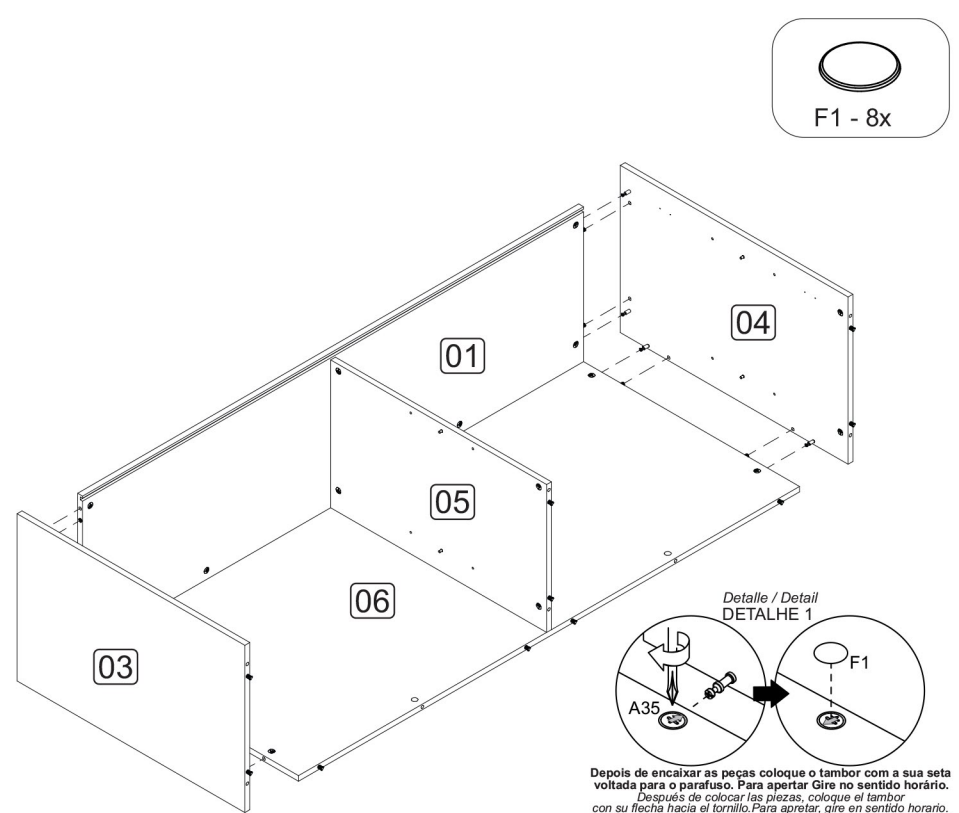

Depois de encaixar as peças coloque o tambor com a sua seta voltada para o parafuso. Para apertar Gire no sentido horário.  
Después de colocar las piezas, coloque el tambor con su flecha hacia el tornillo. Para apretar, gire en sentido horario.  
After fitting the parts, place the drum with its arrow facing the screw.  
To tighten, turn clockwise.



F1 - 8x

