

Item	Caixa Box	Qty	Descrição   Descripción	Medidas (mm)   Dimensions (mm)   Size (measurements) (mm)	Código das Peças   Código de las piezas   Parts Code
01	1/2	01	Lateral esquerda   Lateral izquierda   Left side	785x380x15	03153323
02	2/2	01	Divisão   División   Division	785x380x15	03061456
03	1/2	02	Travessa estrutural   Travesa estructural   Structural strut	707x73x15	03301390
04	1/2	01	Travessa frontal gaveta   Travesa delantera cajón   Front tray drawer	707x73x15	03301391
05	2/2	01	Divisão das gavetas   División de los cajones   Drawer partitioning	380x120x15	03153324
06	1/2	01	Rodapé frontal   Rodapié frontal   Front footer	346x73x15	03271380
07	1/2	01	Base   Base   Base	380x346x15	03293233
08	1/2	01	Lateral direita   Lateral derecha   Right side	785x380x15	03153322
09	2/2	01	Tampo   Tapa   Top	1100x397x15	03293232
10	1/2	01	Fundo   Fondo   Bottom	592x370x3	03111628
11	2/2	01	Fundo Espelho   Fondo de espejo   Mirror Background	1096x785x15	03111627
12	2/2	01	Espelho com furo   Espejo con orificio   Mirror with hole	850x480x3	03039152
13	1/2	01	Porta   Puerta   Door	378x356x15	03212207
14	2/2	01	Frente de gaveta maior   Frente de cajón mayor   Largest drawer front	356x192x15	03131255
15	1/2	03	Frente de gaveta   Frente de cajón   Front of drawer	356x120x15	03131254
16	1/2	08	Lado de gaveta   Lado del cajón   Side of drawer	350x90x15	03140604
17	1/2	04	Fundo de gaveta   Fondo del cajón   Drawer bottom	361x302x3	03120533
18	1/2	04	Ripa de trás   Malla detrás   Rear lath	321x90x15	03240710



Ind. e Com. de Móveis Henn  
Mondaí - SC - Brasil  
☎ +55 49 3674.3500  
@moveishenn  
www.henn.com.br

# INSTRUÇÕES DE MONTAGEM

INSTRUCCIONES DE MONTAJE  
ASSEMBLY INSTRUCTIONS

## PENTEADEIRA CHANEL | PENSION CHANEL | CHANEL PENTHOUSE D900-05 BRANCO HP

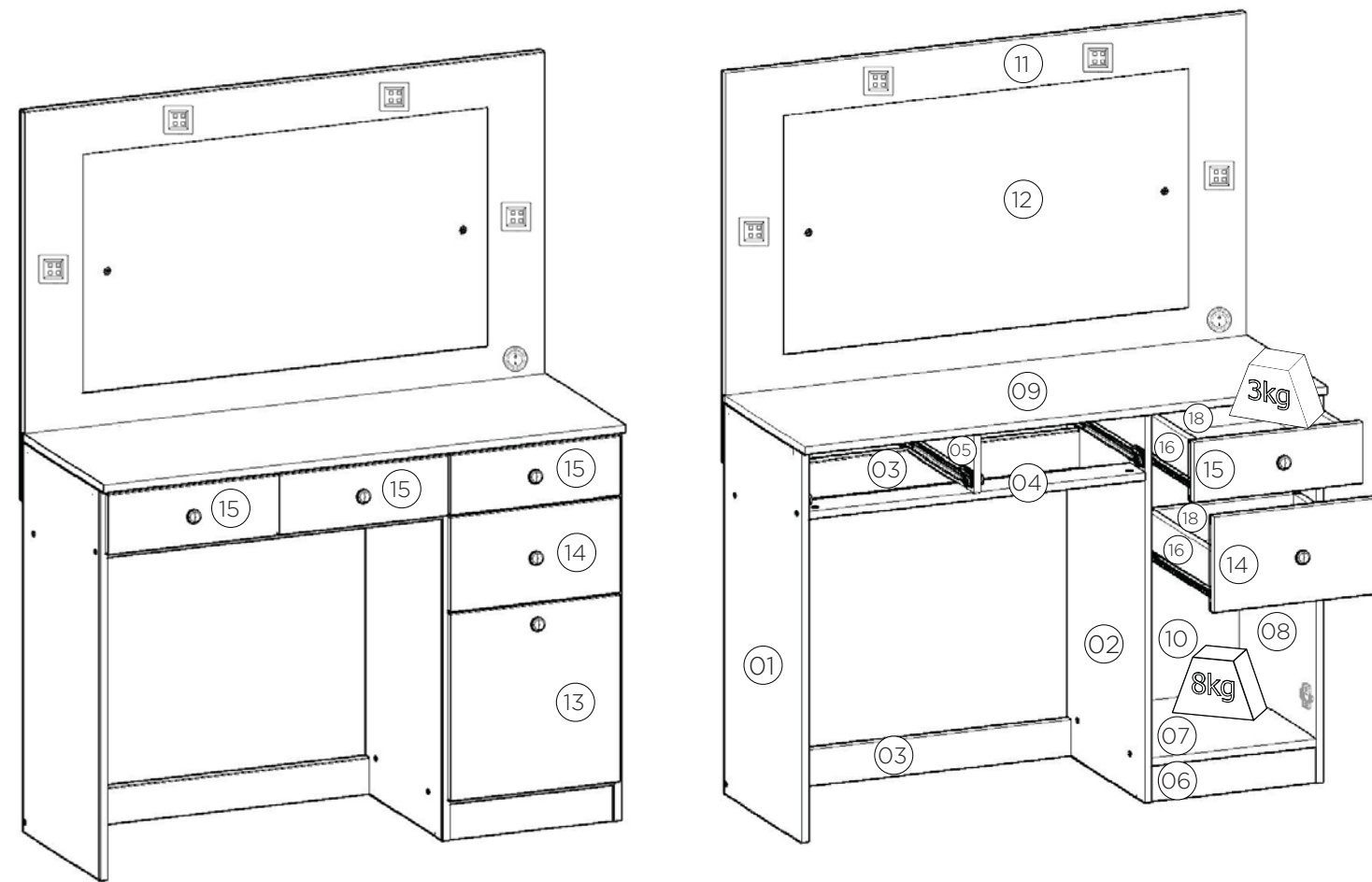

**Pesos máximos recomendados com carga distribuída**  
Peso máximo recomendado con la carga distribuida  
Recommended maximum weights with evenly distributed.

### Requisitos para montagem Requisitor para la montaje Assembly Requirements

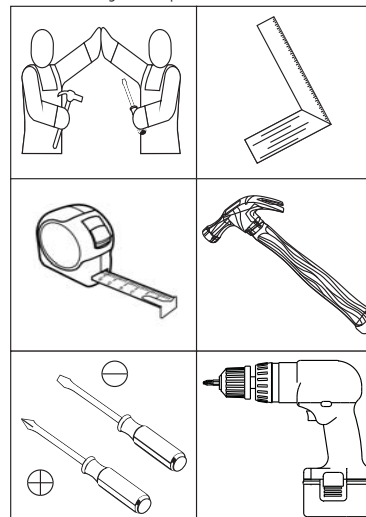

Imagens meramente ilustrativas  
Imágenes meramente ilustrativas  
Images for illustration only

### AVISO

Para limpeza de seu móvel, use uma flanela seca ou umedecida, e não utilize produtos químicos que possam danificar seu produto.

### SISTEMA DE MONTAGEM

O sistema de montagem dos produtos, funciona de acordo com a ordem crescente dos números indicados no desenho. Ex: 01, 02, 03, 04... até a conclusão da montagem.

### ADVERTENCIA

Para limpieza de su móvil, use una flanela seca o húmeda, y no utilice productos químicos que puedan dañar su producto.

### SISTEMA DE MONTAJE

El sistema de montaje de los productos funciona de acuerdo con el orden creciente de los números indicados en el dibujo. Ej.: 01, 02, 03, 04... hasta la conclusión del montaje.

### NOTICE

To clean your furniture, use a dry or wet cloth, and do not use chemicals that may damage your product.

### ASSEMBLY SYSTEM

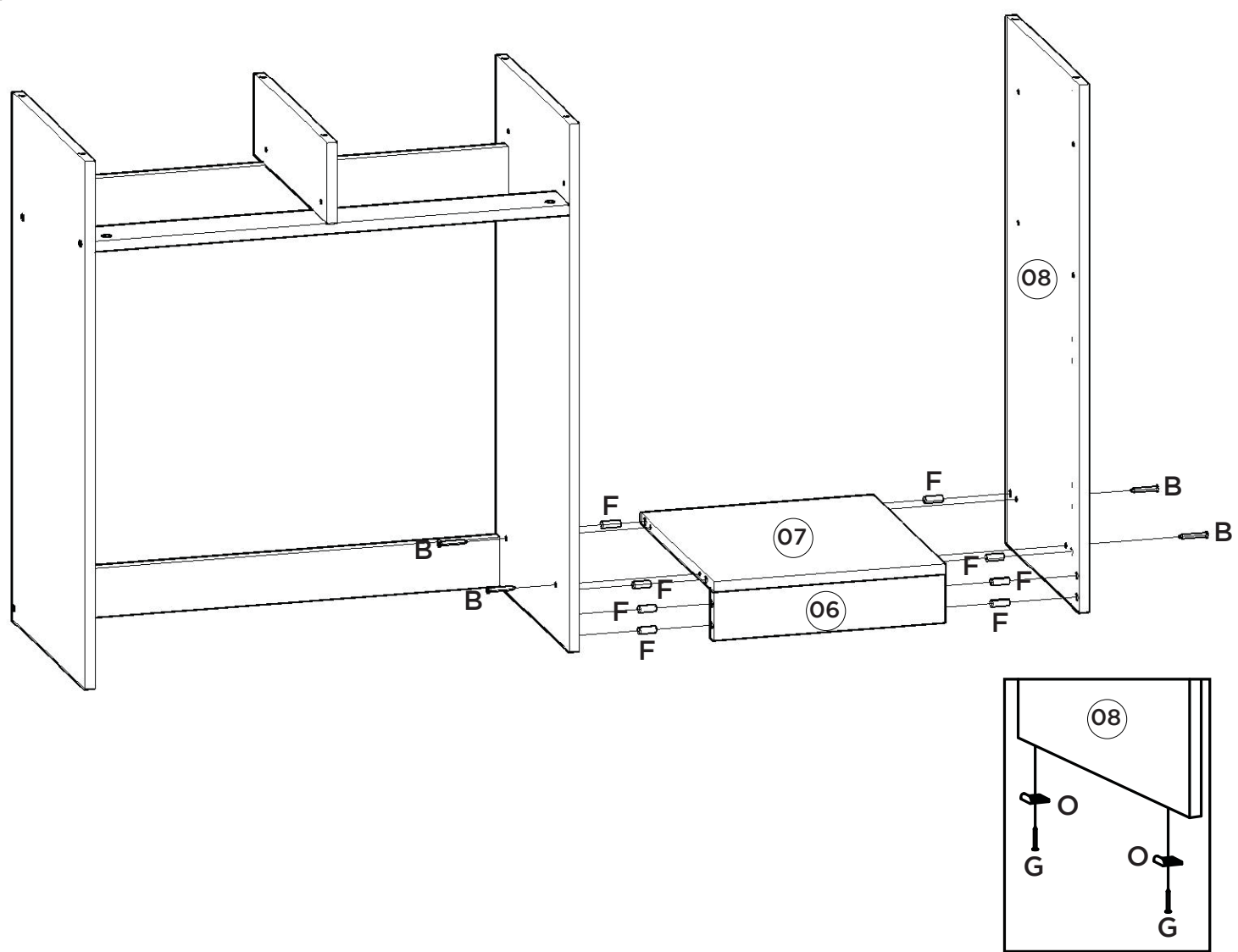
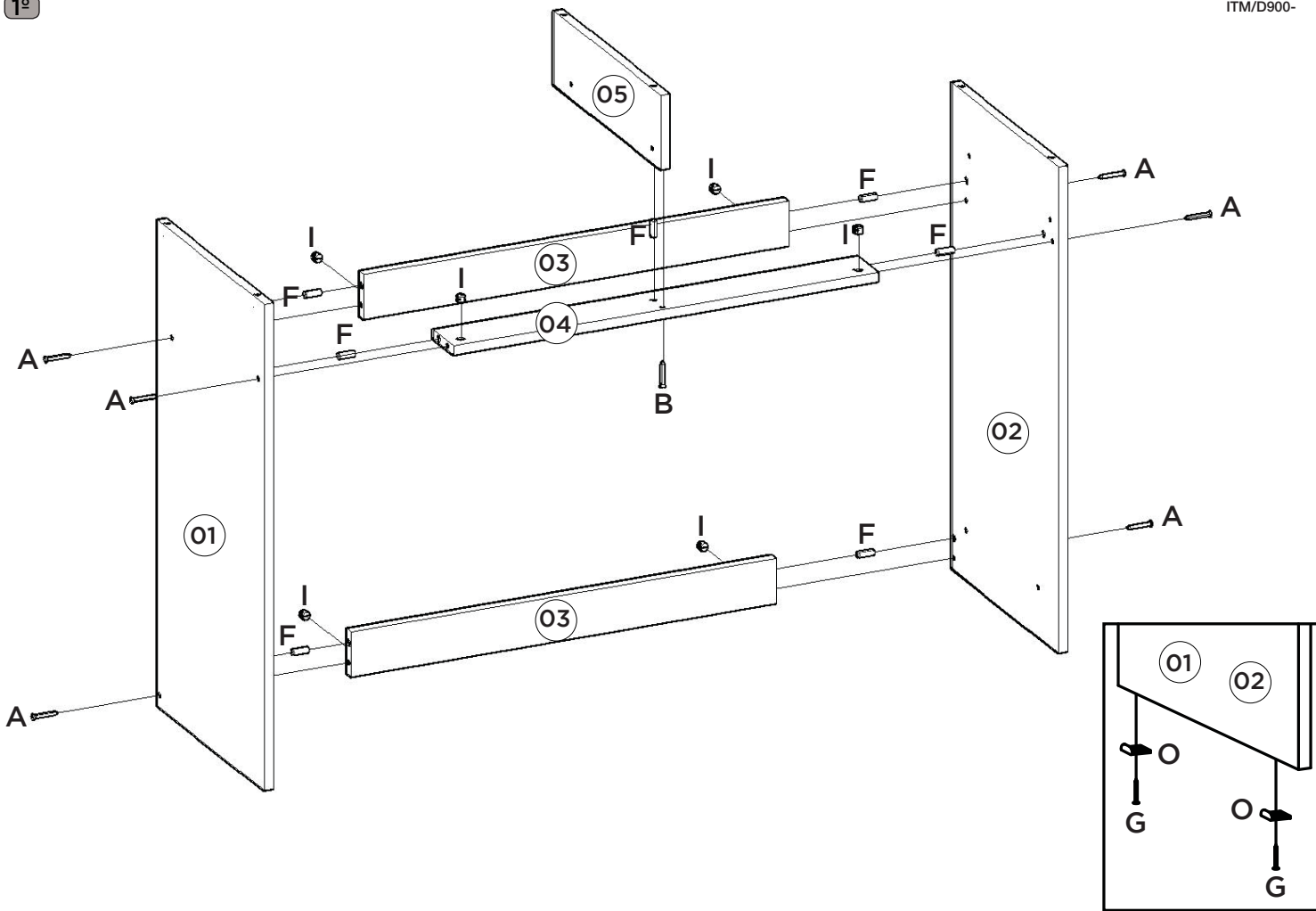

The products' assembly system works according to the increasing order of the indicated numbers. For example: 01, 02, 03, 04 ... to the end of the assembly.







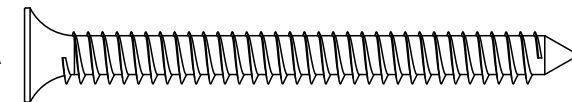
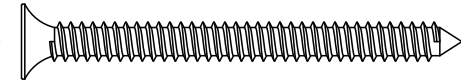
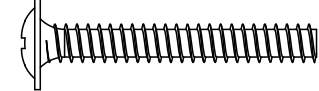
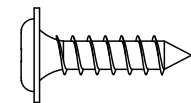
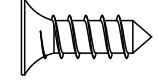
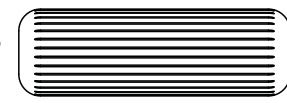

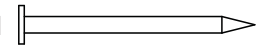



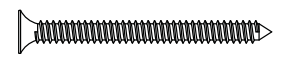

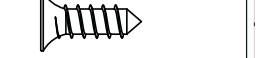





Utilizar componentes abaixo para que sejam conferidos (Escala 1:1)

El uso de componentes a continuación con el fin de conceder (Escala 1:1)

Use components below to be checked (Scale 1: 1)

- A  Parafuso 4,5x50mm CHT. / Tornillo 4,5x50mm CHT. / Screw 4,5x50mm CHT.
- B  Parafuso 3,5x40mm CHT. / Tornillo 3,5x40mm CHT. / Screw 3,5x40mm CHT.
- C  Parafuso 3,5x25mm FLA. / Tornillo 3,5x25mm FLA. / Screw 3,5x25mm FLA.
- D  Parafuso 3,5x14mm FLA. / Tornillo 3,5x14mm FLA. / Screw 3,5x14mm FLA.
- E  Parafuso 3,5x12mm CHT. / Tornillo 3,5x12mm CHT. / Screw 3,5x12mm CHT.
- F  Cavilha 8x25mm / Cinta 8x25mm / Dowel 8x25mm
- G  Prego 12x12 anelado / Clavo 12x12mm Anillado / Ringed Nails 12x12mm
- H  Prego 10x10mm / Clavo 10x10mm / Nail 10x10mm

Ferragens | Herrajes | Hardware

<b>A</b>  06x Parafuso 4,5x50mm CHT. Tornillo 4,5x50mm CHT. Screw 4,5x50mm CHT.	<b>B</b>  17x Parafuso 3,5x40mm CHT. Tornillo 3,5x40mm CHT. Screw 3,5x40mm CHT.	<b>C</b>  05x Parafuso 3,5x25mm FLA. Tornillo 3,5x25mm FLA. Screw 3,5x25mm FLA.	<b>D</b>  16x Parafuso 3,5x14mm FLA. Tornillo 3,5x14mm FLA. Screw 3,5x14mm FLA.	<b>E</b>  56x Parafuso 3,5x12mm CHT. Tornillo 3,5x12mm CHT. Screw 3,5x12mm CHT.
<b>F</b>  58x Cavilha 8x25mm Cinta 8x25mm Dowel 8x25mm	<b>G</b>  14x Prego 12x12mm Anelado Clavo 12x12mm Anillado Ringed Nails 12x12mm	<b>H</b>  13x Prego 10x10mm Clavo 10x10mm Nail 10x10mm	<b>I</b>  06x Porca cilíndrica Tuerca cilíndrica Cylindrical nut	<b>J</b>  12x Cantoneira plástica Cantonera plástica Plastic angle brackets
<b>K</b>  02x Calço metal 5mm Calzado metálico 5mm 5 mm metal shim	<b>L</b>  02x Dobradiça metal 26mm Bisagra de metal 26mm 26 mm metal hinge	<b>M</b>  04x Corrediça metal 350mm Corredera de metal 350mm Sliding metal 350mm	<b>N</b>  05x Puxador Catar Branco Tirador Catar Blanco Catar White Handle	<b>O</b>  06x Sapata "L" 16x20mm Zapata "L" 16x20mm "L" shoe 16x20mm
<b>P</b>  01x Kit Led com 4 Luminárias Kit Led con 4 Lámparas Led Kit with 4 Lights	<b>Q</b>  02x Sachê de cola Bolsa de pegamento Glue bag	<b>R</b>  07x Adesivo tapa parafuso 10mm Adhesivo tapón de tornillo 10mm Bolt cover adhesive 10mm	<b>S</b>  02x Giz de correção Tiza de corrección Chalk of correction	<b>T</b>  01x <b>HENN</b> Etiqueta resinada Henn Etiqueta resinada Henn Henn resin label

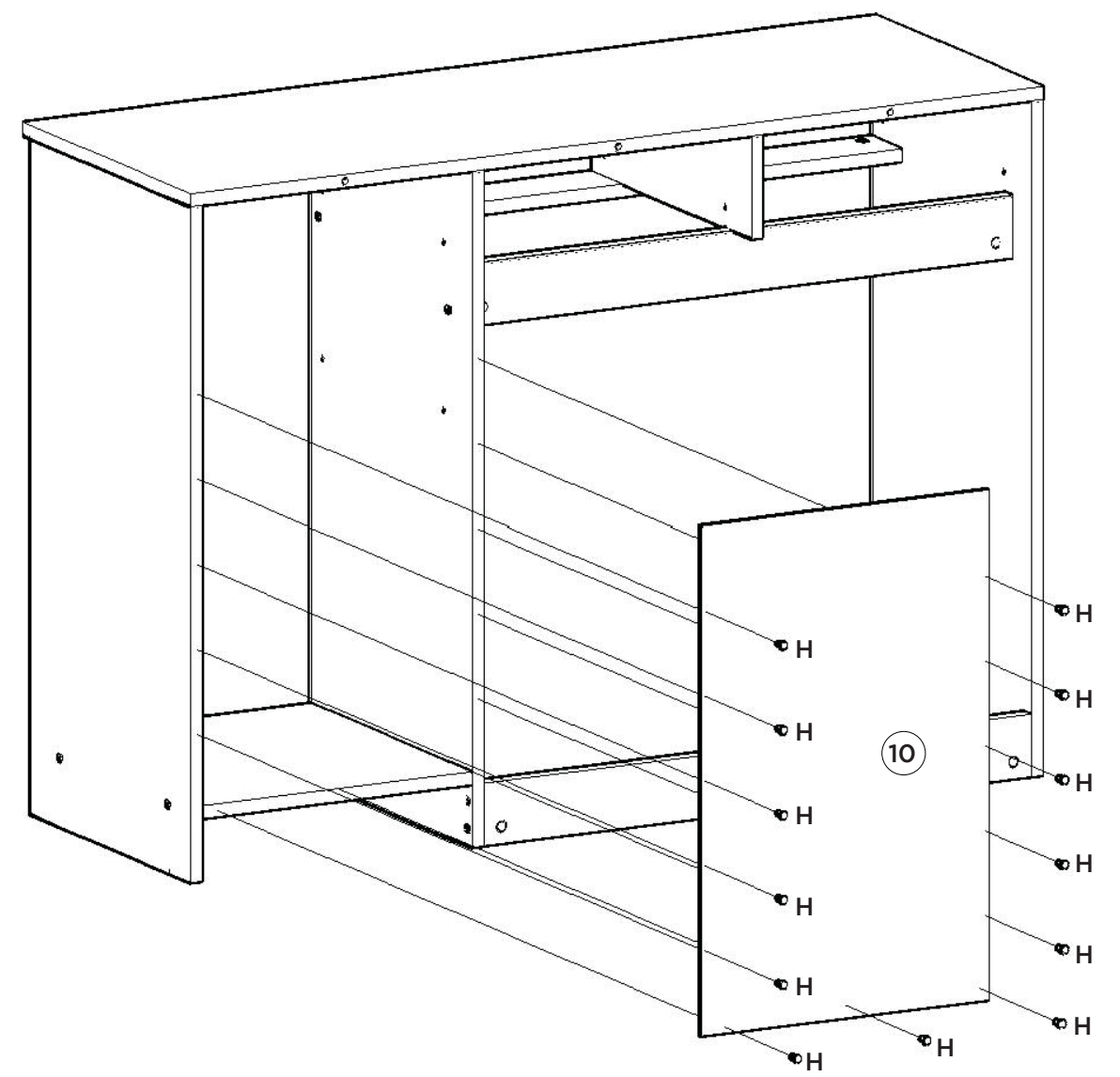
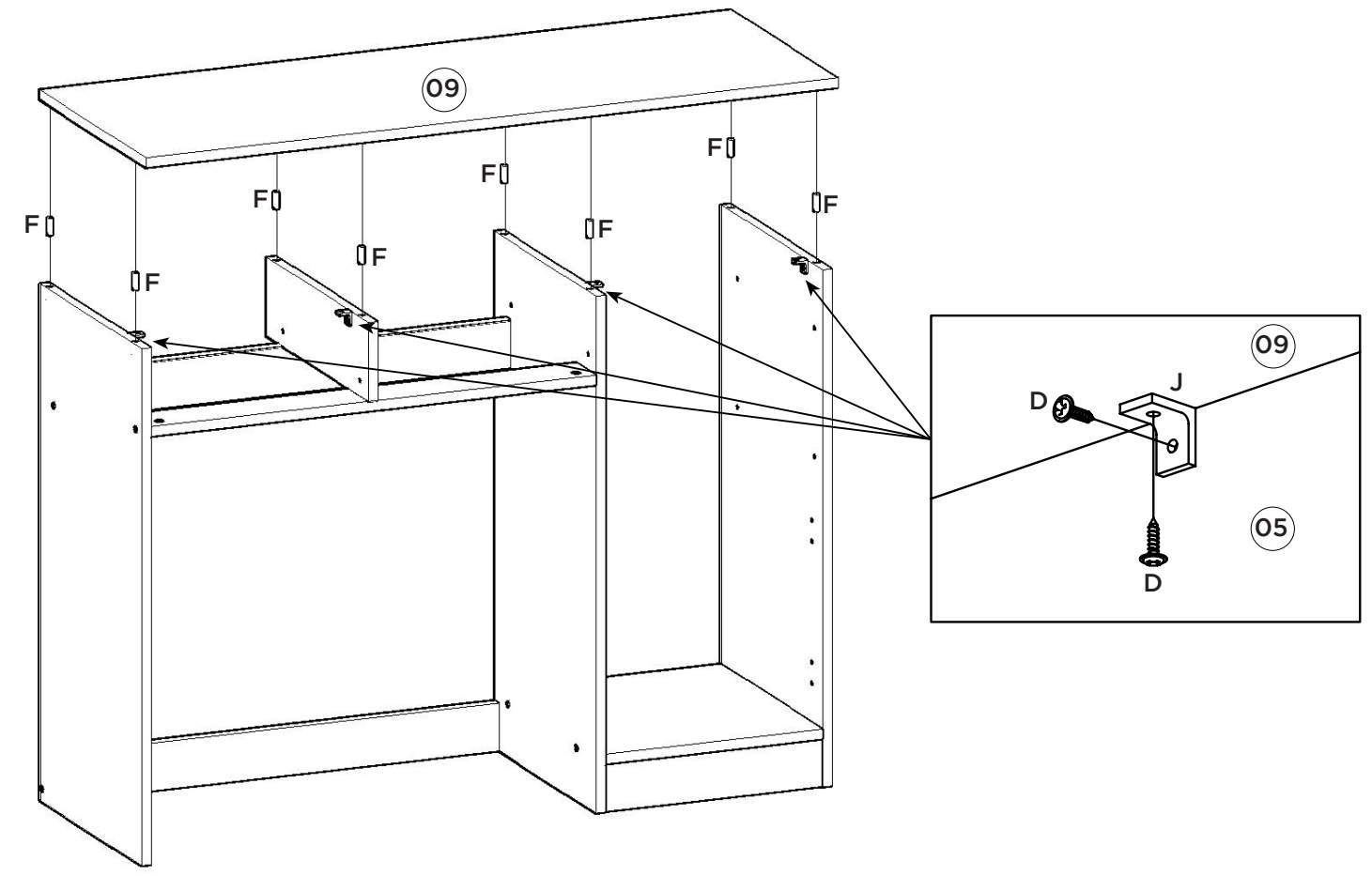
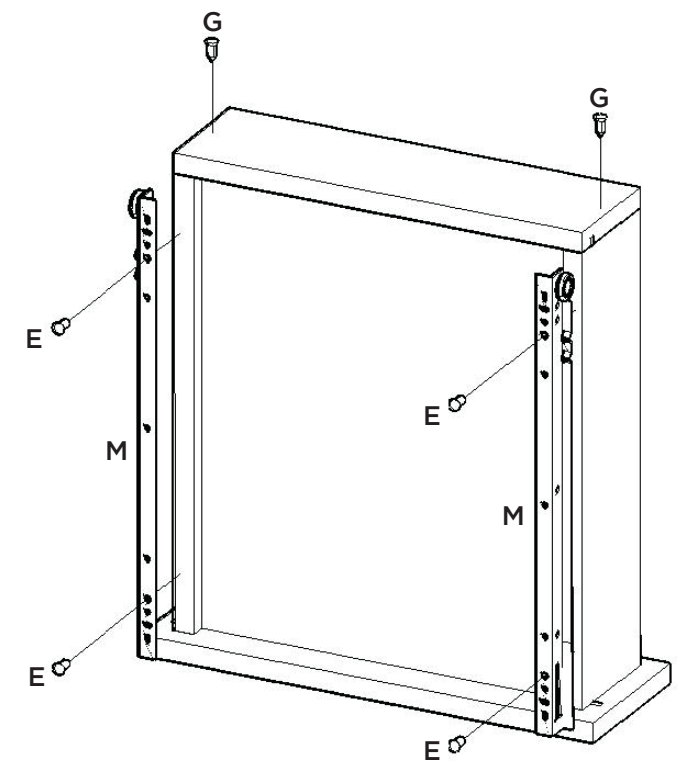
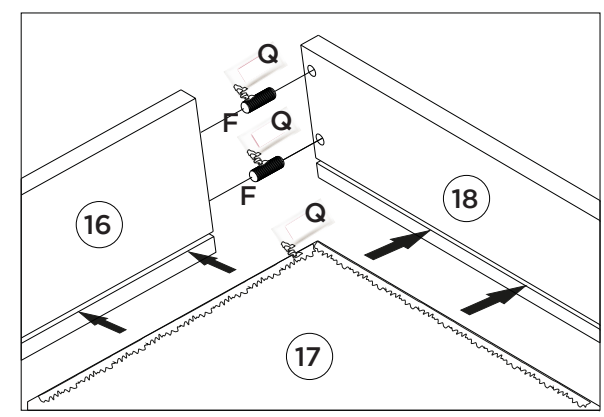
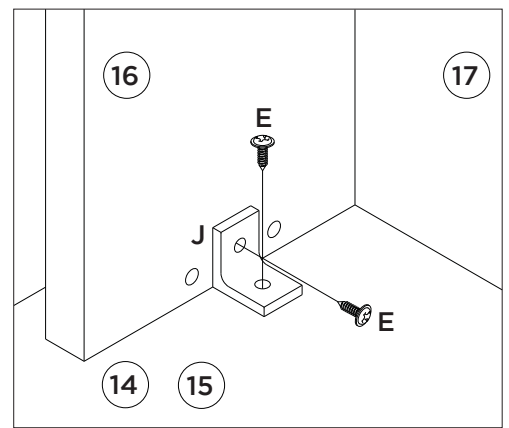
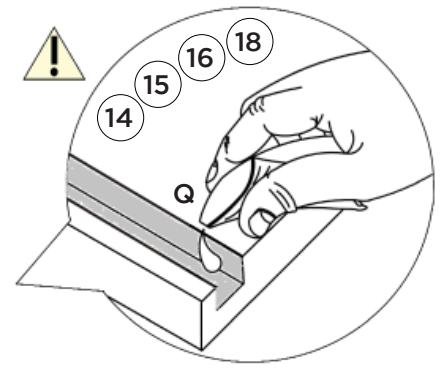
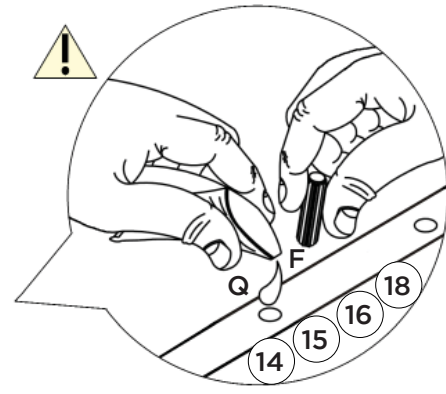
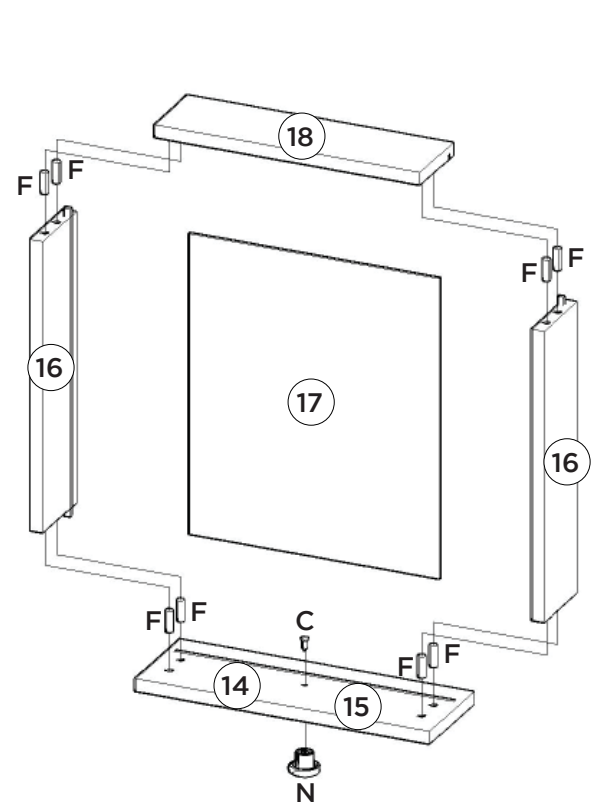

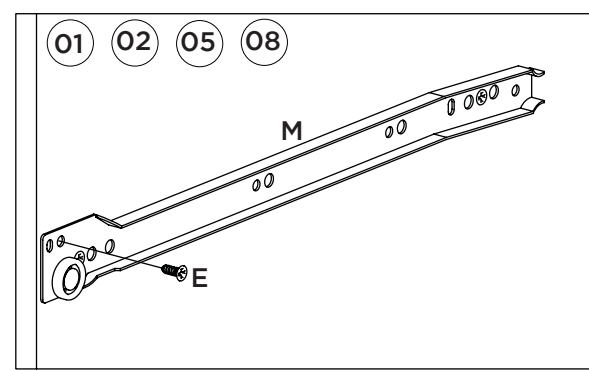
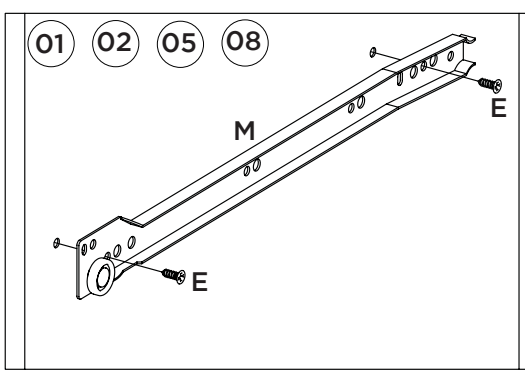
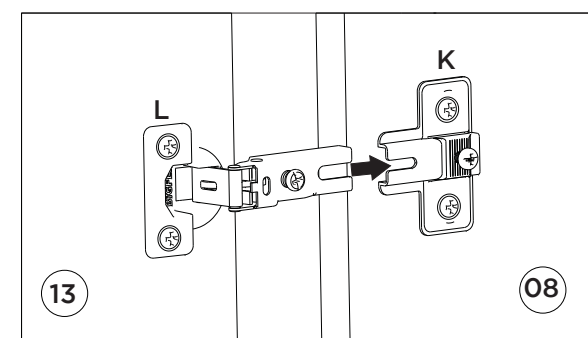
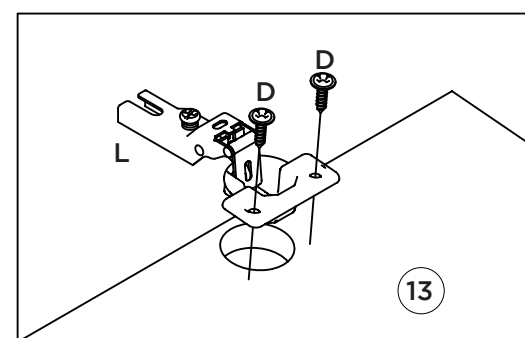
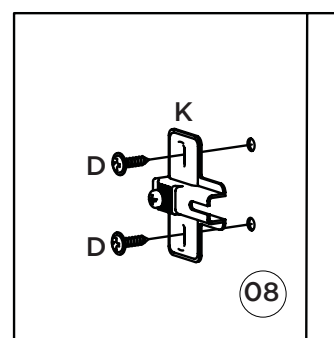
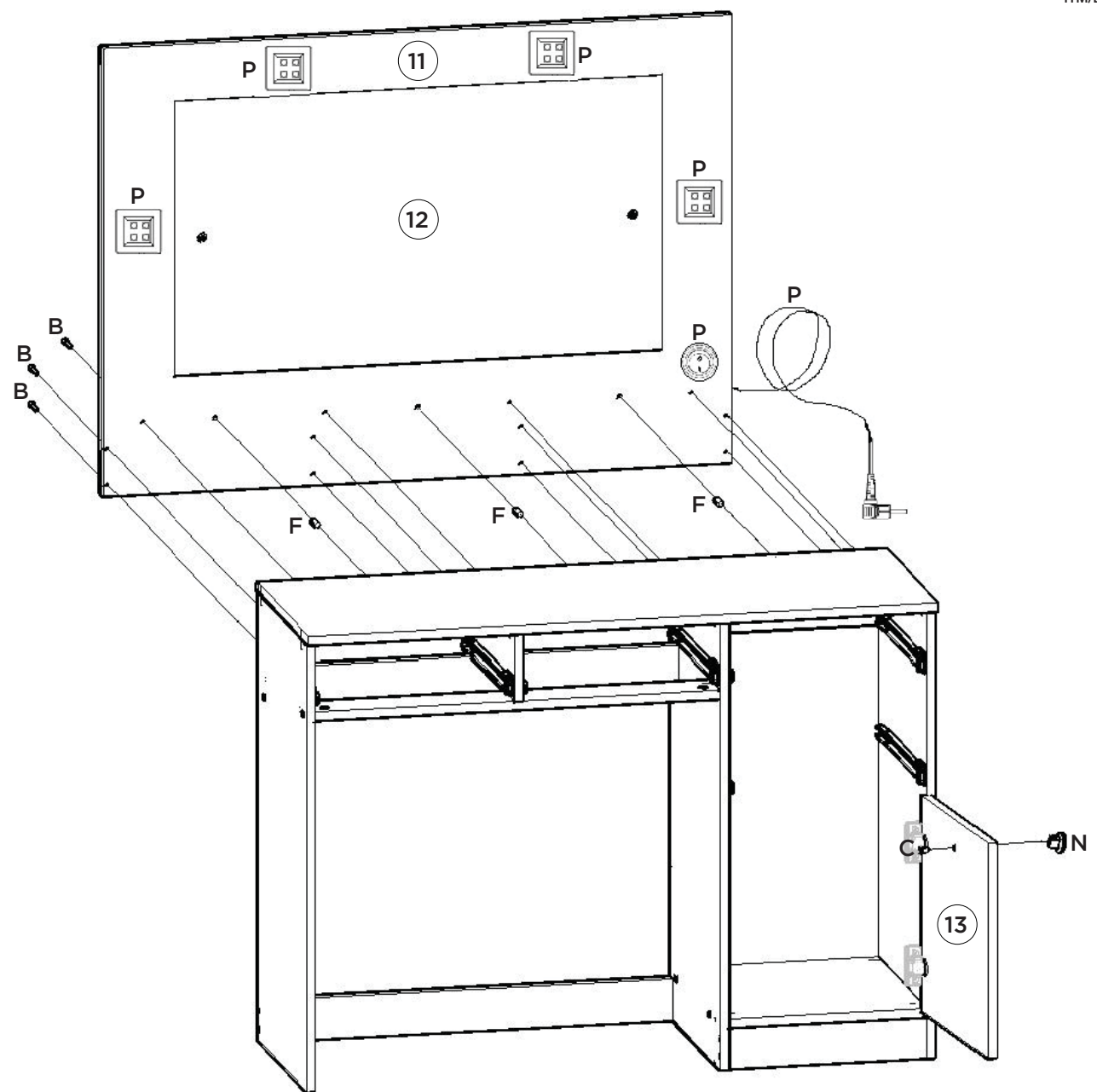

Vista Traseira

Vista Trasera

Back view

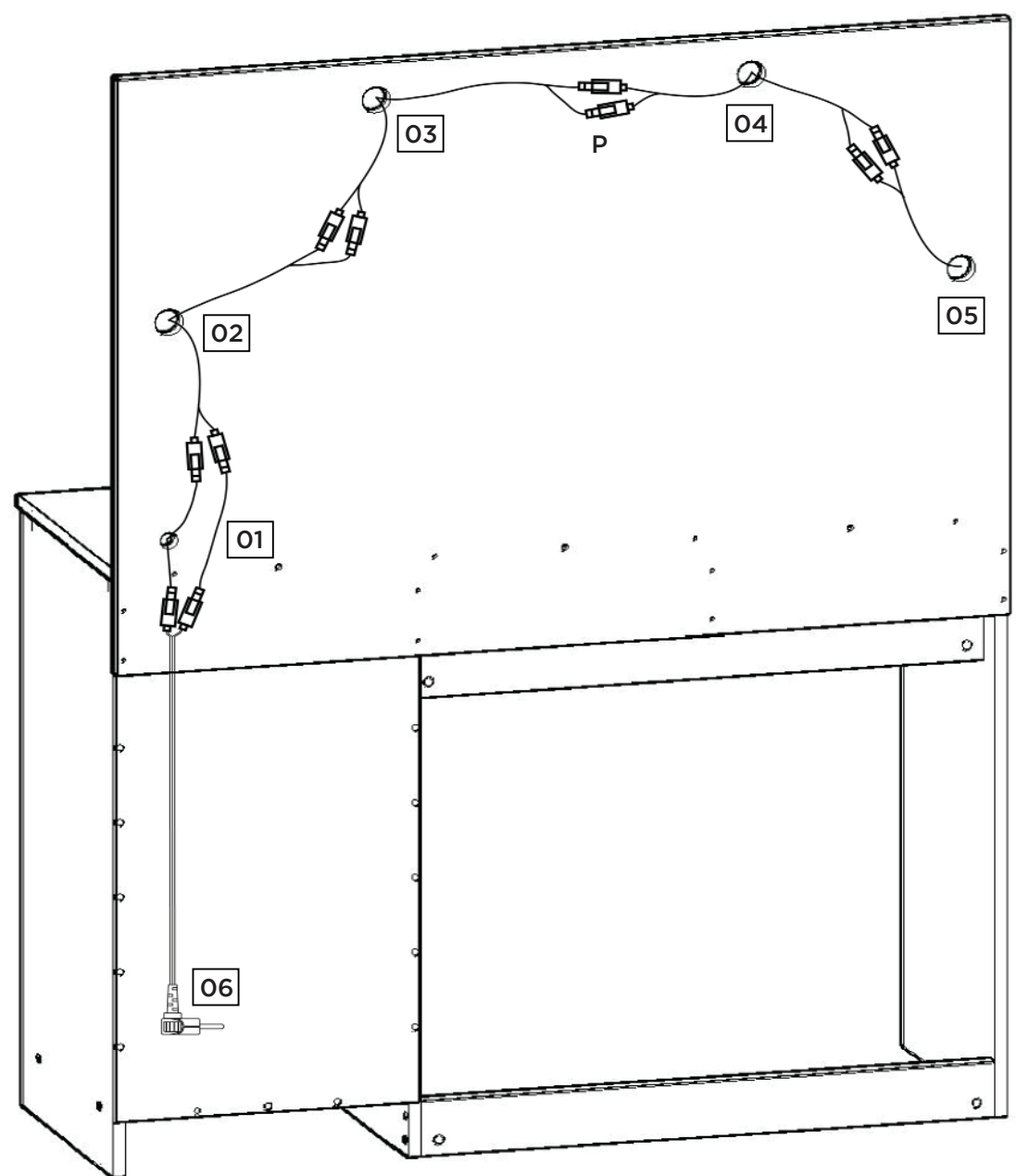

Detalhe da fiação do Kit Luminária Led.

Detalle del cableado del Kit Luminaria Led.

Detail of wiring Kit Led lamp.



**Atenção:** A colocação do LED deve seguir conforme demonstrado a cima respeitando a sequência da numeração. Esta sequência de numeração acompanha a instrução do Kit LED.

**Atención:** La colocación del LED debe seguir como se muestra arriba respetando la secuencia de la numeración. Esta secuencia de La numeración acompaña la instrucción del Kit LED.

**Caution:** The LED placement must follow as shown in the respect the sequence of numbering. This sequence of number accompanies the LED Kit instruction.