

INSTRUÇÃO DE MONTAGEM

INSTRUCCIONES DE MONTAJE

Roupeiro 02 Portas 03 Gavetas EspelhoDiamante

Armario 02 Puertas 03 Cajones Espejo Diamante

Referência/Cor

- M313-42 - Fendi
 M313-83 - Moka

Requisitos para montagem

Requisitor para la montaje

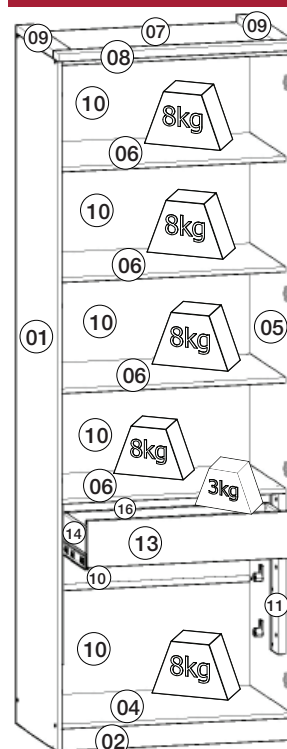
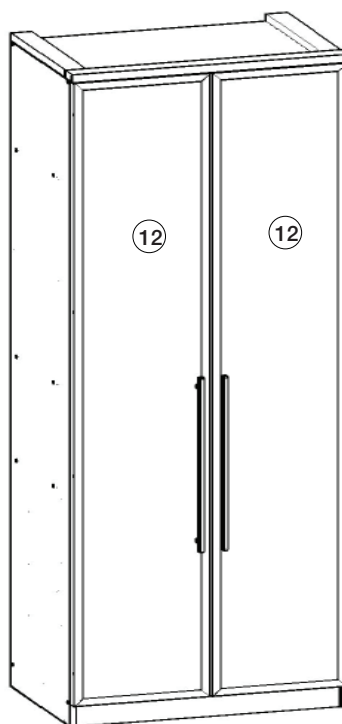
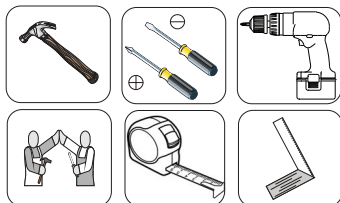

Pesos máximos recomendados com carga uniformemente distribuídas.

Peso máximo recomendado con la carga distribuida uniformemente.

Lista de Peças / Lista de piezas

Item	Caixa	Qtd	Descrição/ Descripción	Medidas (mm)	M313-42 Fendi	M313-83 Moka
01	1/2	01	Lateral esquerda/ Lateral izquierda	2275x520x15	03152838	03152468
02	2/2	01	Rodapé frontal / Rodapié frontal	770x73x15	03271168	03271011
03	2/2	01	Rodapé traseiro / Rodapié trasero	770x73x15	03271010	03271010
04	2/2	01	Base/ Base	770x520x15	03292721	03292366
05	1/2	01	Lateral direita/ Lateral derecha	2275x520x15	03152837	03152467
06	2/2	04	Prateleira / Estante	770x450x15	03221041	03221041
07	2/2	01	Tampo superior/ Tapa superior	770x520x15	03292722	03292367
08	1/2	01	Moldura frontal/ Cornija frontal	800x60x25	03161270	03160417
09	1/2	02	Moldura lateral/ Cornija lateral	475x60x25	03161271	03160418
10	1/2	06	Fundo/ Fondo	790x365x3	03111248	03111248
11	1/2	02	Ripa lateral/ Lado ripa	530x80x25	03250556	03250556
12	1/2	02	Porta espelho/ Puerta espejo	2195x391x20	03032233	03032233
13	2/2	03	Frente de gaveta/ Frente del cajón	712x152x15	03130940	03130940
14	2/2	06	Lado de gaveta/ Lado del cajón	350x110x15	03140494	03140494
15	2/2	03	Fundo de gaveta/ Fondo del cajón	676x361x3	03120433	03120433
16	2/2	03	Ripa de trás/ Listón trasero	695x110x15	03240600	03240600

SISTEMA DE MONTAGEM

O sistema de montagem dos produtos, funciona de acordo com a ordem crescente dos números indicados no desenho. Ex: 01, 02, 03, 04... até a conclusão da montagem.

AVISO

Para limpeza de seu móvel, use uma flanela seca ou umedecida, e não utilize produtos químicos que possam danificar seu produto.

SISTEMA DE MONTAJE

El sistema de montaje de productos funciona de acuerdo con el orden de los números indicados en el dibujo. Ejemplo: 01, 02, 03, 04 ... hasta la realización de la asamblea.

ADVERTENCIA

Para la limpieza de sus muebles, utilice un trapo seco o humedecido, y no utilice productos químicos que puedan dañar el producto.

Lista de Ferragens



A união (V) deve ser usada somente quando este módulo for acoplado a outro módulo componível Henn, para unir duas peças de 15mm. Caso ele seja usado separadamente, a utilização do união não se faz necessário.

La unión (V) se debe utilizar sólo cuando el módulo está acoplado a otro módulo composable Henn, para unirse a dos 15mm piezas. Si se utiliza por separado, el uso de unión no es necesario.

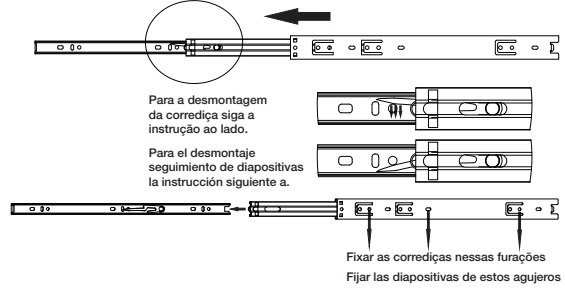
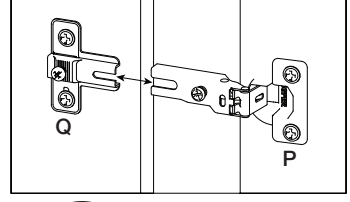
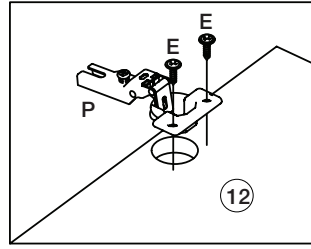
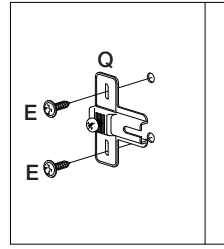
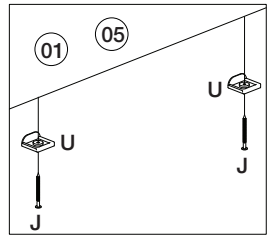
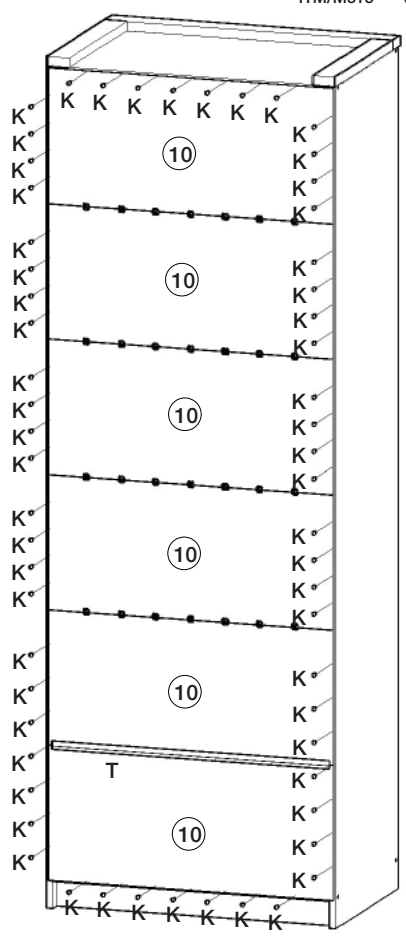
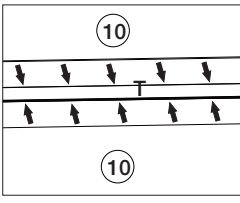
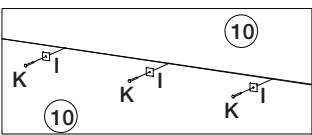
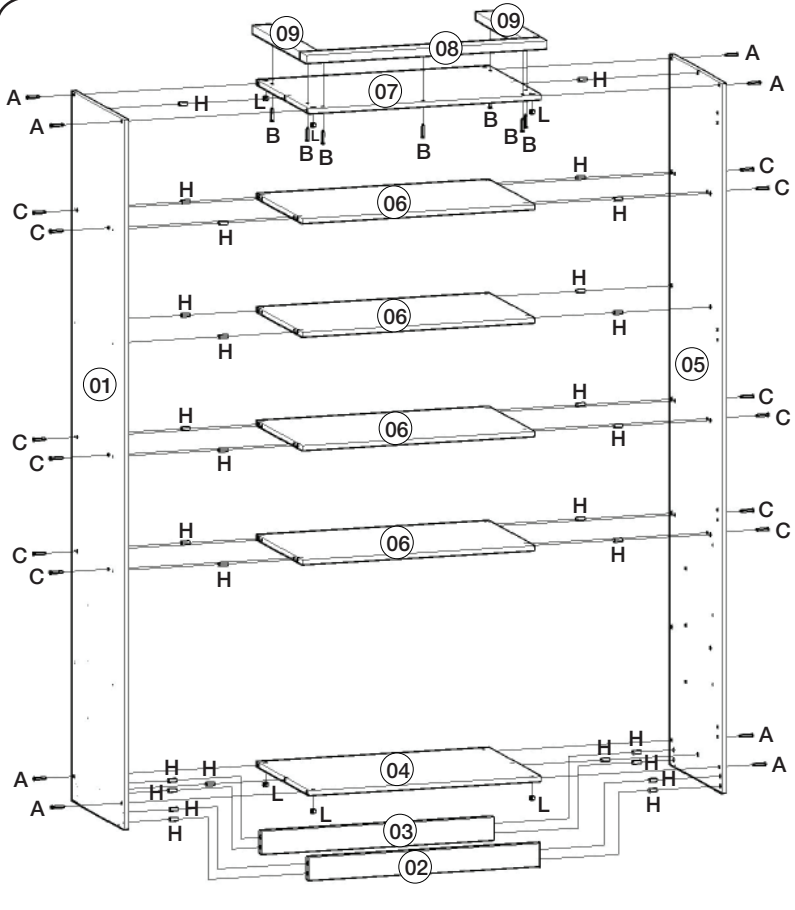

Montagem gaveta 3x. Monte cajón 3x.

