

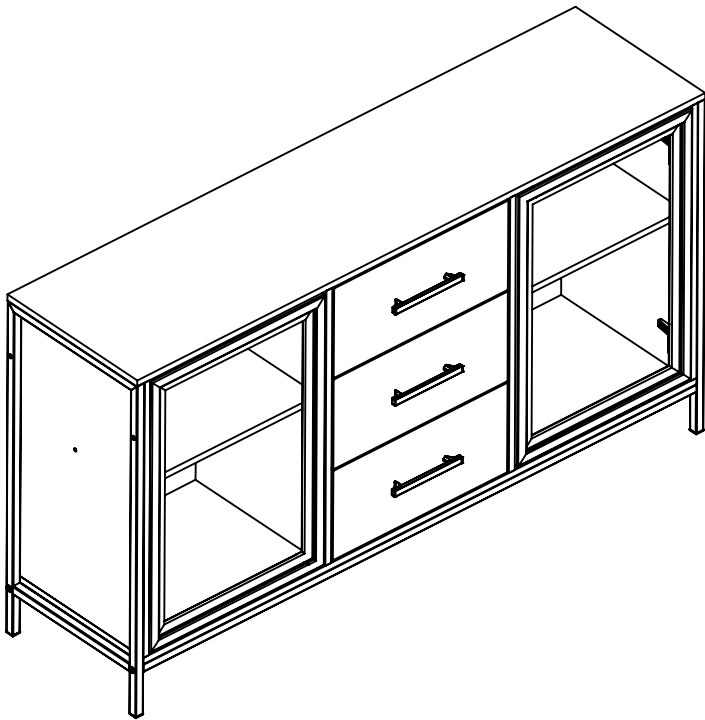











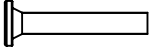





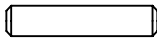

PLACA&PONTO

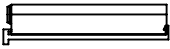

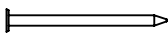

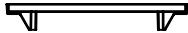

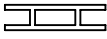
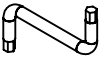

**P1068 - OAK/PRE**  
**BALCÃO BUFFET DUO**

**01**

LISTA DE FERRAGENS

REF.	DESCRIÇÃO	VINHETA	QTD.
<b>A</b>	Paraf. Sext. Int. 1/4"x40 ZP	 	04
<b>B</b>	Paraf. C. Flange. 4x30mm ZP	 	21
<b>C</b>	Paraf. Mad. CC Chipboard 3,5x40 ZA	 	25
<b>D</b>	Paraf. Mad. CC Chipboard 3,5x14 ZA	 	78
<b>E</b>	Cavilha 6x30mm	 	38
<b>F</b>	Kit Corrediça Telescópica 350mm		03
<b>G</b>	Fecho Toque Magnético	 	02
<b>H</b>	Prego 10mm	 	60
<b>I</b>	Cola Branca		01
<b>J</b>	Puxador Glass Preto 128mm	 	03
<b>K</b>	Tapa Furo 13mm Papel Oak		06
<b>L</b>	Cantoneira Metal Arredondada		15
<b>M</b>	Perfil H 465mm		01
<b>N</b>	Chave Allen 4mm		01

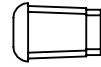
**LISTA DE FERRAGENS**

REF.	DESCRIÇÃO	VINHETA	QTD.
<b>O</b>	Ponteira Interna 20x20 Preta		05
<b>P</b>	Dobradiça Caneco 35mm		04
<b>Q</b>	Calço Dobradiça 35mm		04
<b>K</b>	Junção Fundo		06
<b>L</b>	Ponteira 20x20mm C/ Rosca 1/4" Preta	 	01
<b>M</b>	Pé Nivelador 1/4"x3/4" (N010) Preto		01

VISTA EXPLODIDA

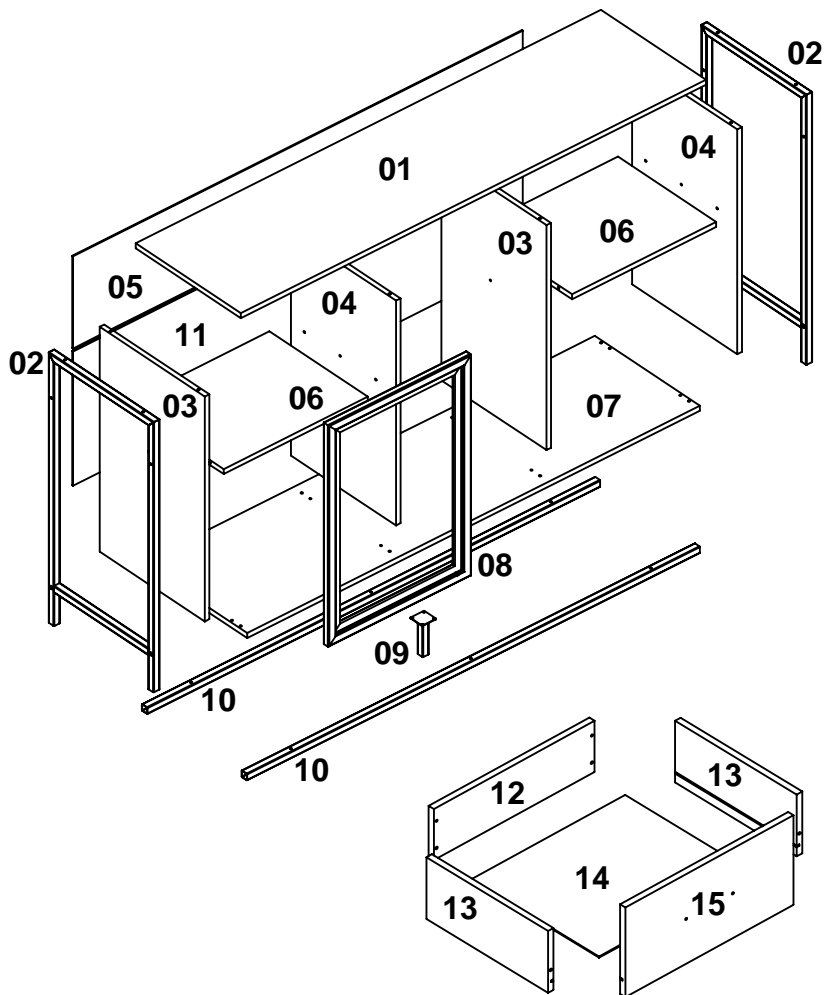

**LISTA DE PEÇAS**

Nº	CÓDIGO	DESCRIÇÃO	QTD.	DIMENSÕES (mm)		
				COMP.	LARG.	ESP.
01	13100191-05	TAMPO/ TOPO/ TOP	01	1500	390	15
02	13100191-53	REQUADRO LATERAL/ RECUADRO LATERAL/ SIDE FOOT	02	805	390	20
03	13100191-03	LATERAL ESQUERDA/DIVISÓRIA 1/ LATERAL IZQUIERDO/DIVISOR 1/ LEFT SIDE/PARTITION 1	02	670	390	15
04	13100191-06	LATERAL DIREITA/DIVISÓRIA 2/ LATERAL DERECHO/DIVISOR 2/ RIGHT SIDE/PARTITION 2	02	670	390	15
05	13100191-04	FUNDO MENOR CAIXARIA/ FONDO MENOR/ SMALLER BACK	01	1450	340	03
06	13100191-07	PRATELEIRA INTERNA/ ESTANTE INTERNO/ INTERNAL SHELF	02	465	365	15
07	13100191-02	BASE/ BASE/ BASE	01	1460	390	15
08	13100191-57	PORTA C/ VIDRO FUMÊ/ PUERTA CON VIDRO FUMÊ/ DOOR WITH SMOKED GLASS	02	660	462	20
09	13100188-66	PÉ CENTRAL/ PIE CENTRAL/ CENTRAL SUPPORT FOOT	01	120	45	45
10	13100191-55	TRAVESSA INFERIOR/ TRAVERZA INFERIOR/ LOWER CROSSBAR	02	1460	20	20
11	13100191-17	FUNDO MAIOR CAIXARIA/ FONDO MÁS GRANDE/ BIGGER BACK	01	1450	400	03
12	13100191-14	COSTAS GAVETA/ ESPALDILLAS DEL CAJÓN/ DRAWER BACK	03	440	124	15
13	13100191-13	LATERAIS GAVETA/ LATERALES DE CAJÓN/ DRAWER SIDES	06	350	150	15
14	13100191-16	FUNDO DE GAVETA/ FONDO DE CAJÓN/ DRAWER BOTTOM	03	445	367	03



# PLACA&PONTO

## 01

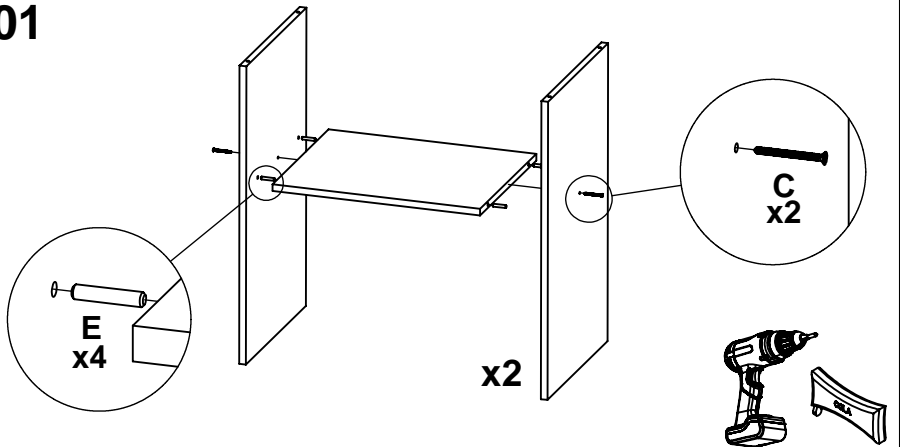

BR.: Passe cola (I) nas marcações das laterais e prateleiras e encaixe as cavilhas (E). Depois parafuse os parafusos (C) nas marcações para fixar melhor.

ES.: Aplique cola (I) en las marcas de los laterales y estantes e inserte los pasadores (E). A continuación, atornille los tornillos (C) en las marcas para fijarlos mejor.

EN.: Apply glue (I) to the markings on the sides and shelves and insert the dowels (E). Then screw the screws (C) into the markings to secure them better.

## 02

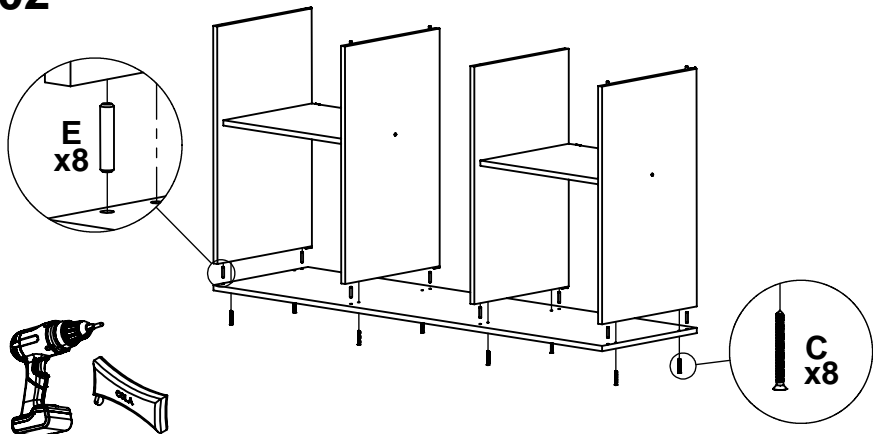

BR.: Passe cola (I) nas marcações das laterais e da base e encaixe as cavilhas (E). Depois, parafuse os parafusos (C) para fixar melhor.

ES.: Aplica pegamento (I) en las marcas de los laterales y la base e inserta los pasadores (E). A continuación, atornilla los tornillos (C) para fijarlos mejor.

EN.: Apply glue (I) to the markings on the sides and base and insert the dowels (E). Then, tighten the screws (C) to secure them better.

# PLACA&PONTO

## 03

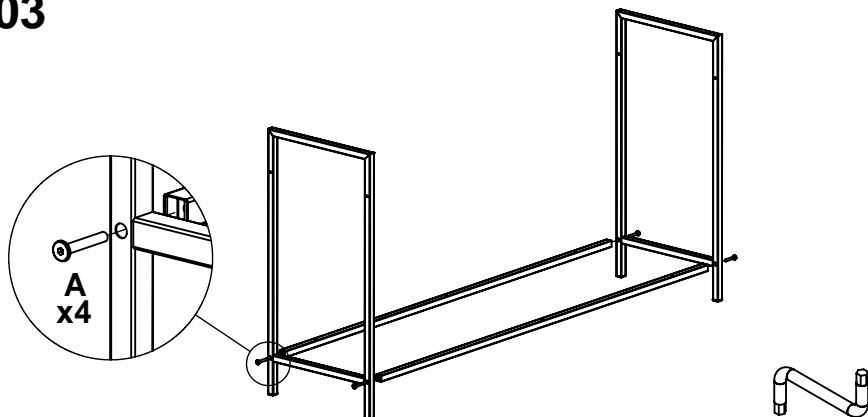

BR.: Posicione os requadros laterais e as travessas inferiores e parafuse-os (A).

ES.: Coloque los marcos laterales y los travesaños inferiores y atorníllelos (A).

EN.: Position the side frames and lower crossbars and screw them in place (A).

## 04

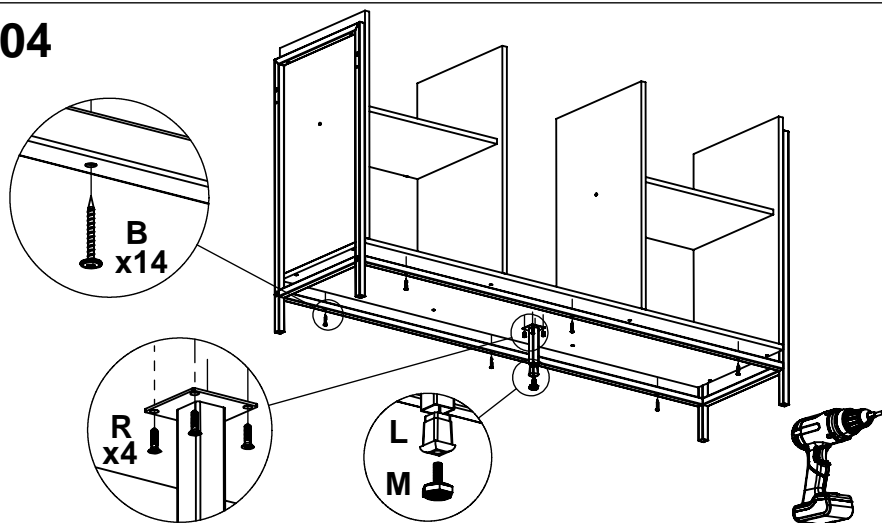

BR.: Posicione o móvel na estrutura metálica e parafuse os parafusos (B) para fixá-los. Depois, parafuse (R) o pé central e coloque a ponteira (L) e a sapata (M).

ES.: Coloque el mueble en la estructura metálica y atornille los tornillos (B) para fijarlos. Después, atornille (R) el pie central y coloque la punta (L) y la zapata (M).

EN.: Position the furniture on the metal frame and tighten the screws (B) to secure them. Then screw (R) the center foot in place and attach the tip (L) and shoe (M).

# PLACA&PONTO

05

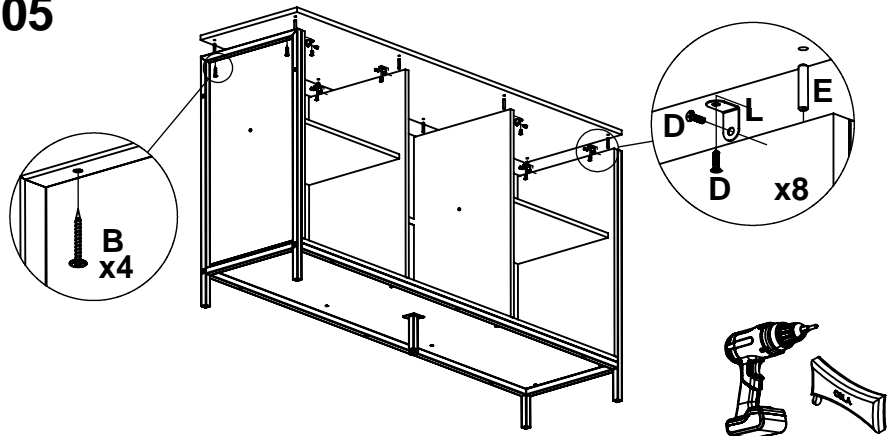

BR.: Passe cola nas marcações do tampo e encaixe as cavilhas (E) e parafuse (D) as cantoneiras (L). Depois, parafuse os parafusos (B) nas laterais para fixar melhor.

ES.: Aplica cola a las marcas de la tapa e inserta los pasadores (E) y atornilla (D) las esquinas (L). Después, atornilla los tornillos (B) en los laterales para fijarlos mejor.

EN.: Apply glue to the markings on the top and fit the dowels (E) and screw (D) the corner brackets (L). Then screw the screws (B) into the sides for better fastening.

06

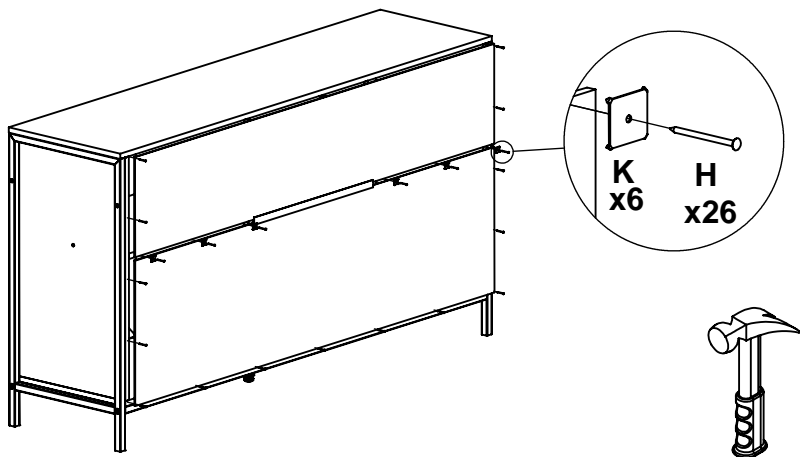

BR.: Posicione os fundos e o perfil H (M) e pregue-os até estarem bem fixados.

ES.: Coloque los fondos y el perfil H (M) y clávelos hasta que queden bien fijados.

EN.: Position the bottoms and the H-profile (M) and nail them until they are securely fastened.

# PLACA&PONTO

## 07

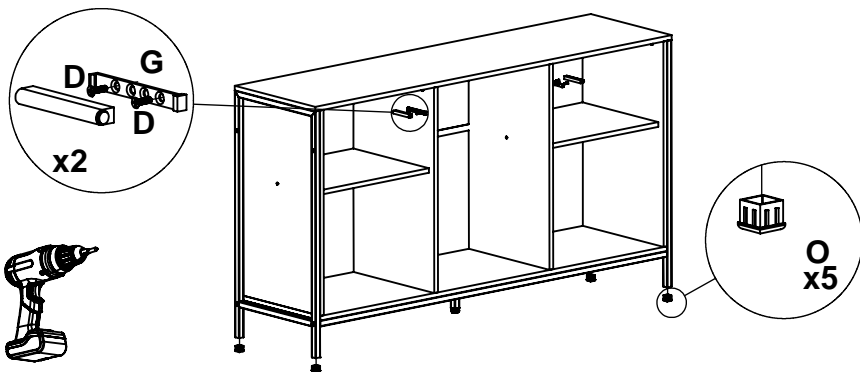

BR.: Posicione os fecho toques (G) e parafuse-os (D) ao móvel. Depois encaixe as ponteiros (O) sob os pés.

ES.: Coloque los cierres (G) y atorníllelos (D) al mueble. A continuación, encaje las puntas (O) debajo de las patas.

EN.: Position the fasteners (G) and screw them (D) to the furniture. Then fit the caps (O) under the feet.

## 08

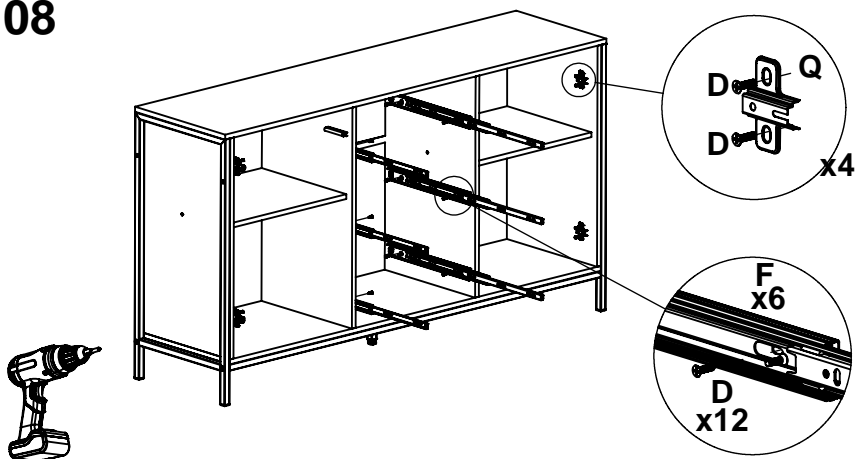

BR.: Posicione as corredeiras (F) e parafuse-as (D) ao móvel conforme as marcações. Depois, parafuse (D) os calços das dobradiças (Q) nas laterais.

ES.: Coloque las guías (F) y atorníllelas (D) al mueble según las marcas. A continuación, atornille (D) las cuñas de las bisagras (Q) en los laterales.

EN.: Position the slides (F) and screw them (D) to the furniture according to the markings. Then screw (D) the hinge brackets (Q) onto the sides.

# PLACA&PONTO

## 09

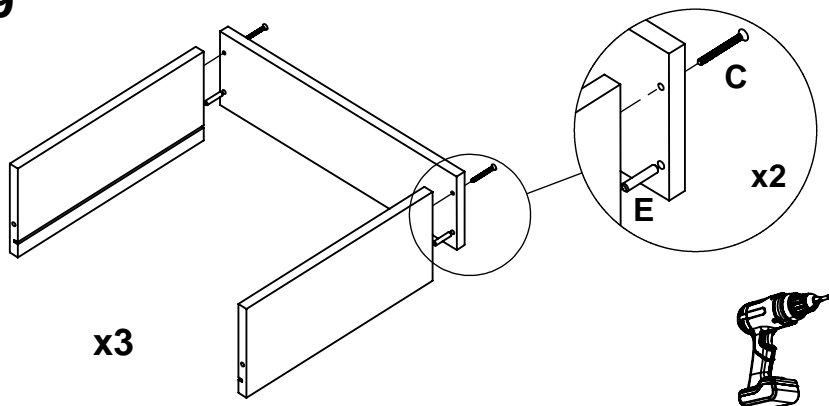

BR.: Passe cola (I) nas marcações das peças das gavetas e encaixe as cavilhas (E). Depois, parafuse os parafusos (D) para fixar melhor.

ES.: Aplica cola (I) en las marcas de las piezas de los cajones e inserta los pasadores (E). A continuación, atornilla los tornillos (D) para fijarlos mejor.

EN.: Apply glue (I) to the markings on the drawer parts and insert the dowels (E). Then screw in the screws (D) to secure them better.

## 10

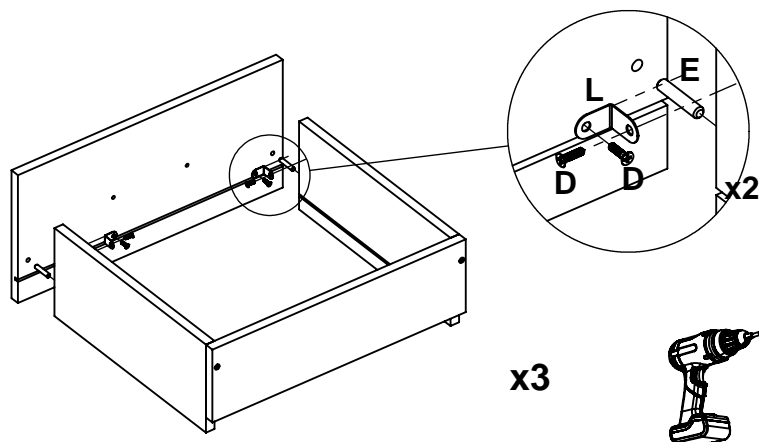

BR.: Passe cola (I) nas marcações das peças da gaveta e encaixe as cavilhas (E). Depois, parafuse (D) as cantoneiras (L) à gaveta.

ES.: Aplique cola (I) en las marcas de las piezas del cajón e inserte los pasadores (E). A continuación, atornille (D) las esquinas (L) al cajón.

EN.: Apply glue (I) to the markings on the drawer parts and insert the dowels (E). Then screw (D) the corner brackets (L) to the drawer.

11

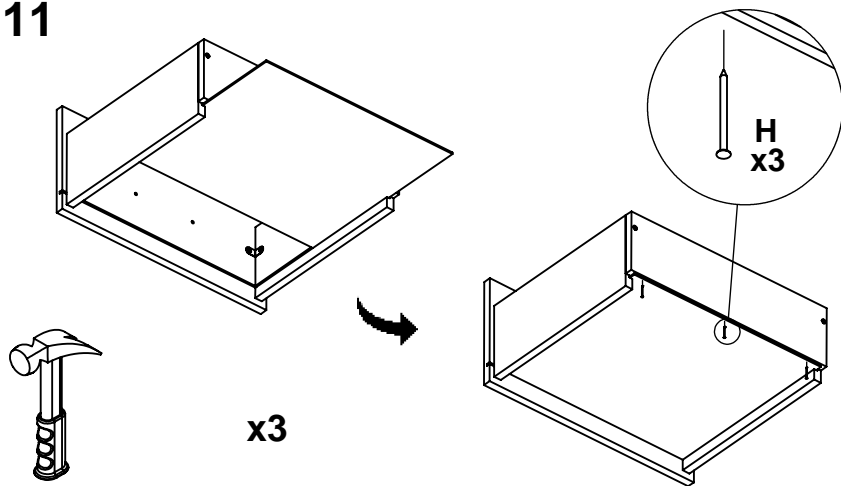

BR.: Encaixe os fundos das gavetas pelos rasgos e pregue-os (H) até estarem bem fixados.

ES.: Encaje los fondos de los cajones en las ranuras y clávelos (H) hasta que queden bien fijados.

EN.: Fit the drawer bottoms into the slots and nail them (H) until they are securely fastened.

12

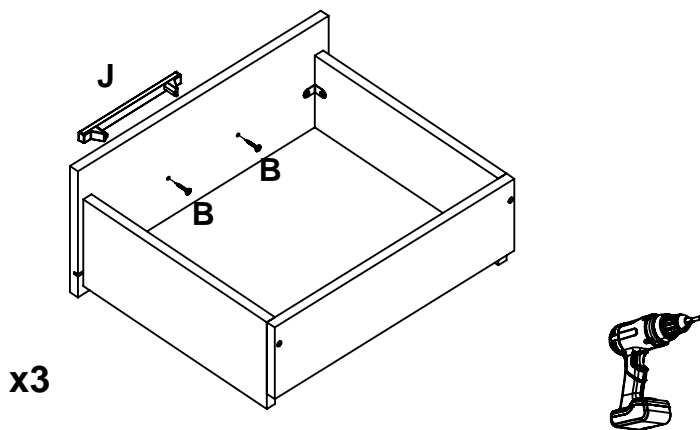

BR.: Posicione os puxadores (J) e parafuse-os (B) às gavetas.

ES.: Coloque los tiradores (J) y atorníllelos (B) a los cajones.

EN.: Position the handles (J) and screw them (B) onto the drawers.

13

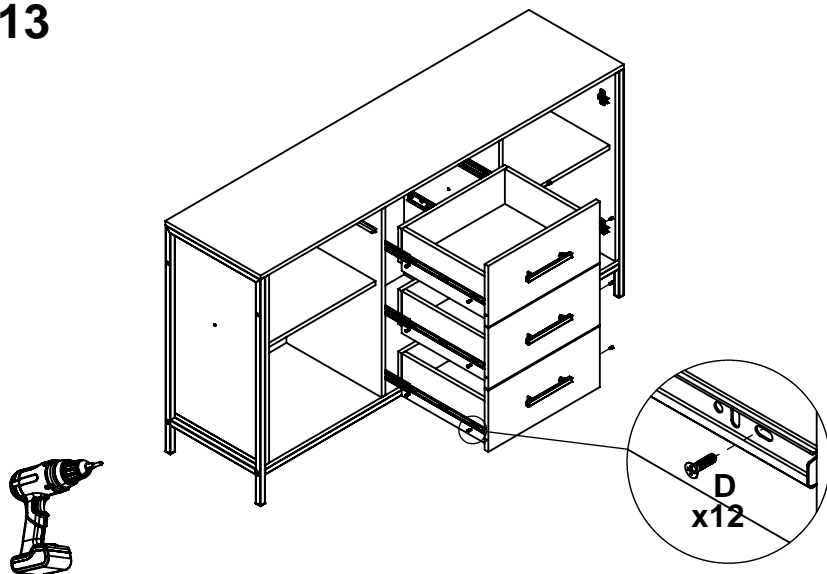

BR.: Posicione as gavetas e parafuse-as (D) às correijas (F) do móvel.

ES.: Coloque los cajones y tornillos (D) a las guías (F) del mueble.

EN.: Position the drawers and screw them (D) to the slides (F) of the cabinet.

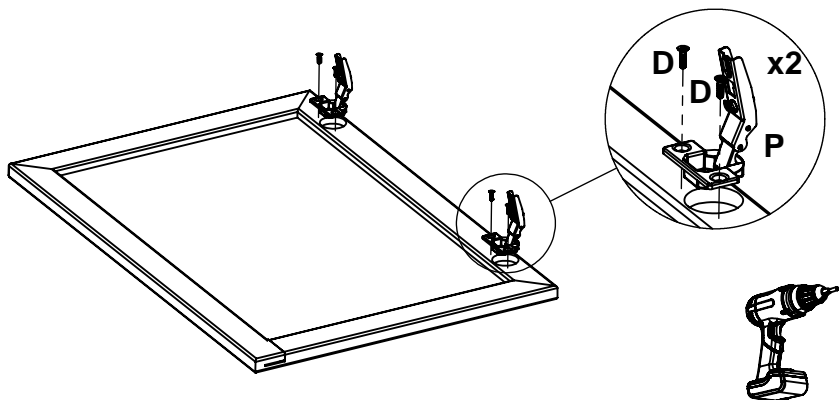

BR.: Encaixe as dobradiças (P) nas portas e parafuse-as (D).

ES.: Encaje las bisagras (P) en las puertas y torníllelas (D).

EN.: Fit the hinges (P) to the doors and screw them in place (D).

13

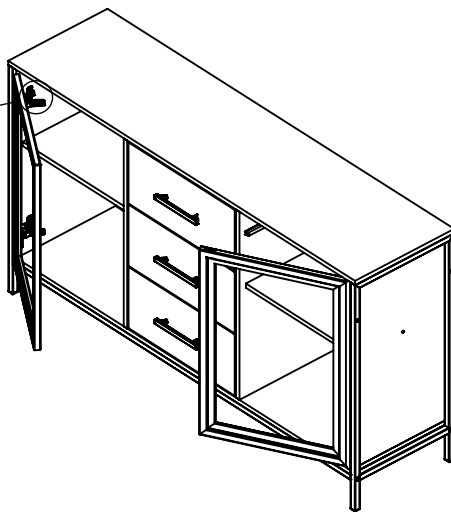
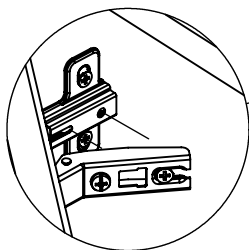

BR.: Posicione as portas e parafuse-as ao móvel.

ES.: Coloque las puertas y atorníllelas al mueble.

EN.: Position the doors and screw them to the cabinet.

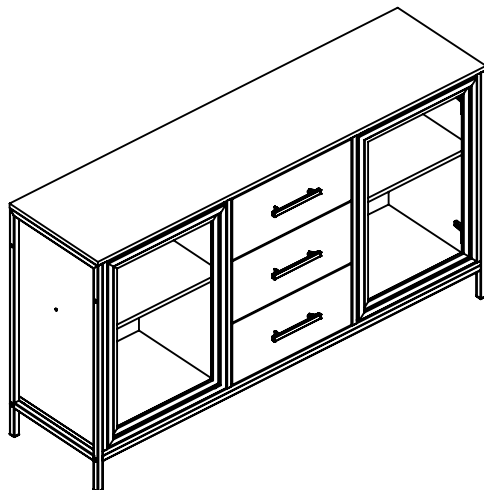



### **RECOMENDAÇÕES:**

- 01** - Examine completamente todas as peças do móvel antes de iniciar o trabalho.
- 02** - Recomenda-se montar o móvel conforme este Manual de Montagem.
- 03** - É de responsabilidade do montador seguir as instruções do Manual de Montagem, que são fundamentais para garantir a estrutura do móvel.
- 04** - Certifique-se de que todos os acessórios utilizados na montagem (parafusos, porcas, ponteiras) estejam fixados o suficiente, totalmente atarraxados, evitando que venham a provocar ferimentos.

### **LIMPEZA:**

- 01** - Pano levemente umedecido com água, seguido de pano seco.
- 02** - Não utilizar produtos químicos ou abrasivos.

### **GARANTIA:**

- 01** - 3 meses para defeitos ou vícios de origem.

### **ADVERTÊNCIAS:**

- 01** - Esteja ciente do risco de chama aberta e outras fontes de calor, tais como aquecedores elétricos, aquecedores a gás etc. nas proximidades do produto.
- 02** - Não utilize o produto se alguma parte estiver quebrada, rasgada ou faltando. Utilizar somente peças de reposição aprovadas pelo fabricante.

### **RECOMENDACIONES:**

- 01** - Examine completamente todas las piezas del mueble antes de empezar el montaje.
- 02** - Recomienda-se montar el mueble de acuerdo con este Manual de Montaje.
- 03** - Es de responsabilidad del montador seguir las instrucciones del Manual de Montaje, que son fundamentales para asegurar la estructura del mueble.
- 04** - Asegure-se de que todos los accesorios utilizados en el montaje (tornillos, tuercas, ponteras) estén fijados el suficiente, totalmente roscados, evitando que vengan a provocar lesiones.

### **LIMPIEZA:**

- 01** - Paño levemente humedecido con agua, siguiendo de paño seco.
- 02** - No utilizar productos químicos o abrasivos.

### **GARANTÍA:**

- 01** - 3 meses para defectos o vicios de origen.

### **ADVERTENCIAS:**

- 01** - Tenga en cuenta el riesgo de llama abierta y otras fuentes de calor, tales como calentadores eléctricos, calentadores de gas, etc. en las proximidades del producto.
- 02** - No utilice el producto si alguna parte está rota, o perdida. Utilizar sólo piezas de repuesto aprobadas por el fabricante.

### **RECOMENDATIONS:**

- 01** - Check completely all the furniture's pieces before start to assemble it.
- 02** - It is recommended to assemble this furniture according to this Assembly's Manual.
- 03** - It is the assembler's responsibility to follow the instructions of this Assembly's Manual, which are essential to ensure the furniture's structure.
- 04** - Ensure that all the accessories used in the assembly (bolts, nuts, tips) are well and enoughly fixed, completely threaded, avoiding injuries from happening.

### **CLEANSING:**

- 01** - Cloth slightly moistened with water.
- 02** - Do not use chemicals or abrasives products.

### **WARRANTY:**

- 01** - 3 months due to manufacture defects.

### **WARNINGS:**

- 01** - Be aware of the risk of open flame and other sources of heat, such as electric heaters, gas heaters etc. around the product.
- 02** - Do not use the product if any part is broken, torn or missing. Only use replacement parts approved by the manufacturer.