

MANUAL DE MONTAGEM
Assembly instructions / Instrucciones de armado

MESA MALTA - 2 GAVETAS

Office table Malta - 2 drawers
Escritorio Malta - 2 cajones

Código 1171 | Revisão 11

NOTA: Este produto pode ser montado com as gavetas para a sua direita ou esquerda.
NOTE: This product can be assembled with drawers to right or left.
NOTA: Este producto se puede armar con los cajones a la derecha o izquierda.

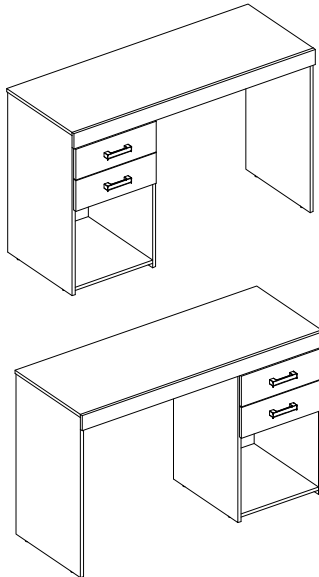

PESO MÁXIMO SUPORTADO PELAS PEÇAS, SENDO ESTE DISTRIBUÍDO UNIFORMEMENTE.

Maximum weight supported by parts, being this evenly distributed.
Peso máximo soportado por las partes, siendo esta distribuido uniformemente.

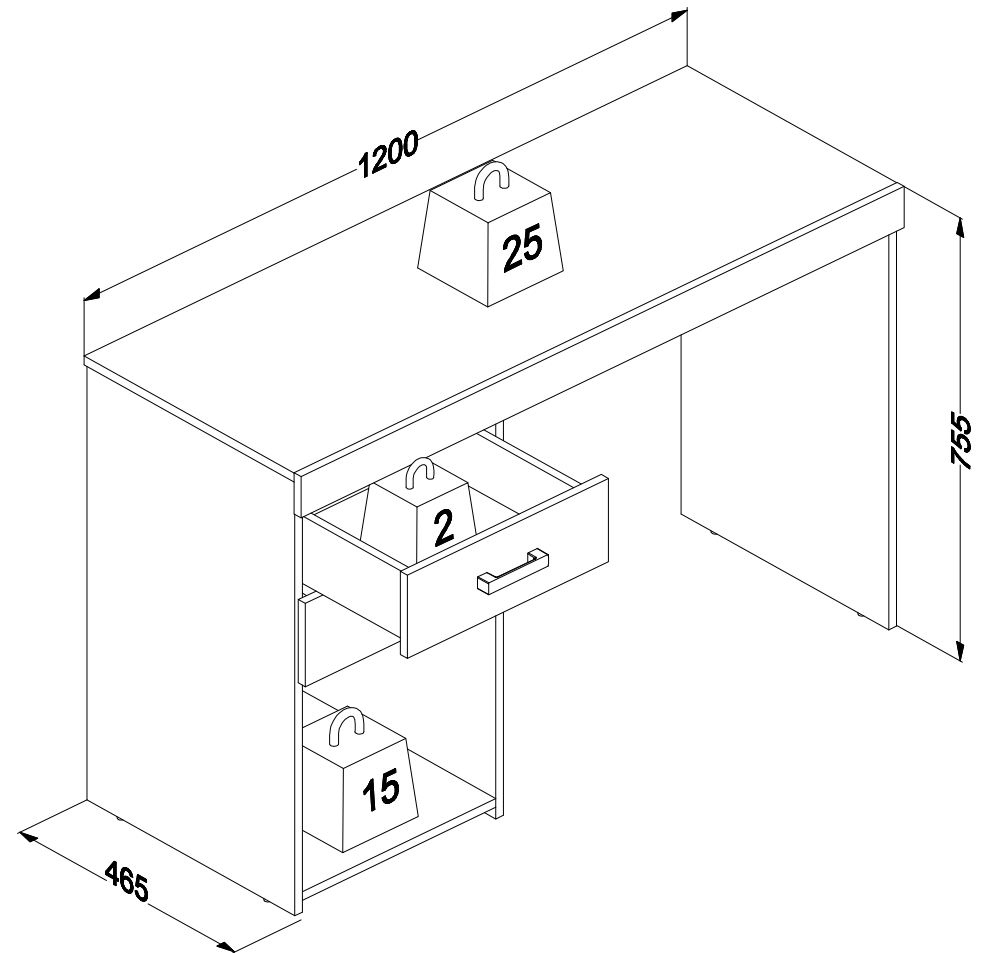

Você vai precisar de/ You will need / Usted necesitará

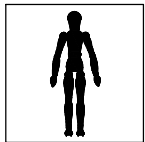

1 Pessoa
1 person
1 persona

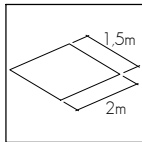

Espaço recomendado para montagem
Recommended space for assemble
Espacio recomendado para el armado

Ferramentas não inclusas
Tools not included / Herramientas no incluidas

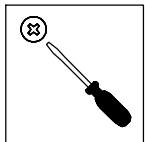

Chave Philips
Screwdriver
Destornillador cruz



Martelo
Hammer
Martillo











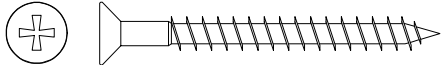

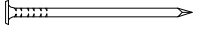
* PESO EM KG/ Weight in Kg/ Peso en Kg
DIMENSÕES EM MM/ Dimensions in mm/ Dimensiones en mm

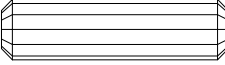
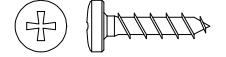
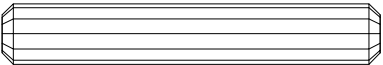
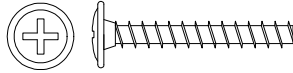
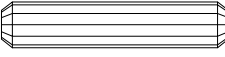
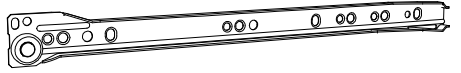
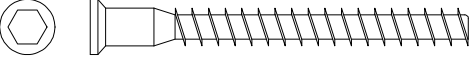
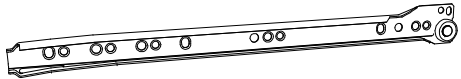
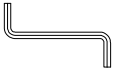
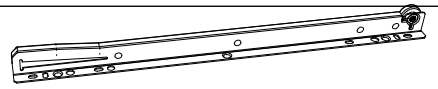
IDENTIFICAÇÃO DOS ACESSÓRIOS/ IDENTIFICATION OF ACCESSORIES/ IDENTIFICACIÓN DE ACCESORIOS

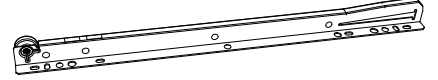
NOTAS: A separação dos acessórios antes de iniciar a montagem facilitará a mesma. Os parafusos e cavilhas estão na escala real. Em caso de dúvida na identificação, coloque o acessório sobre a imagem.

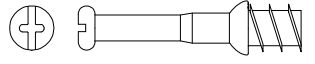
NOTES: The separation of the accessories before you start the assembly will facilitate the same. The screws and dowels are in real scale. In case of doubts about the identification, place the accessory on the image.

NOTAS: La separación de los accesorios antes de comenzar el armado facilitará el mismo. Los tornillos y taquetes son en escala real. En caso de dudas sobre la identificación, coloque el accesorio en la imagen.

A1		Cola Glue Pegamento	13g	01	O		Parafuso chato Flat head screw Tornillo de cabeza plana	4,5x45 mm	04
A2		Sapata redonda Small plastic foot Pie plástico	14 mm	06	N		Prego Nail Clavo	10 x10	06
B5		Cantoneira de metal Metalic angle plates Soporte de metal	46 mm	01	Q		Parafuso chato Flat head screw Tornillo de cabeza plana	3,0x14 mm	16
E		Cavilha Wooden Dowel Pin	8x30 mm	14	S		Parafuso panela Pan head screw Tornillo de pan	3,5x14 mm	10
F		Cavilha Wooden Dowel Pin	8x50 mm	02	T		Parafuso flangeado Flanged head screw Tornillo de cabeza flangeada	3,5x25 mm	04
F1		Cavilha Wooden Dowel Pin	6x30 mm	16	V		Corrediça lateral esquerda Metallic slide the left field Corredera lateral izquierda	350 mm	02
G		Parafuso estrutural Structural screw Tornillo estructural	5,0x50 mm	08	W		Corrediça lateral direita Metallic slide the right field Corredera lateral derecha	350 mm	02
H		Chave allen Allen key Llave Allen	5,0x50 mm	01	X		Corrediça gaveta esquerda Drawer slide left Corredera izquierda cajón	350 mm	02
H9		Tapa furo plástico Junction of tops União de capas	5 mm	06	Y		Corrediça gaveta direita Drawer slide right Corredera derecha cajón	350 mm	02
I		Tampa parafuso estrutural Structural screw cover Tapa tornillo estructural	-	06	Z		Tapa furo plástico Tapones plásticos Plastic hole plugs	8 mm	04
J		Haste minifix simples Simple minifix screw Tornillo minifix simple	-	13					
K3		Puxador Handle Tirador	96 mm	02					
K4		Suporte fixação vistas Fixing bracket of frames Soporte de fijación molduras	-	03					
L		Tambor minifix Drum lock Tambor minifix	12 mm	13					
M		Tapa furo adesivo Bore patch adhesive Tapones ashesivo	-	05					

IDENTIFICAÇÃO DAS PEÇAS/ PARTS IDENTIFICATION/ IDENTIFICACIÓN DE LAS PIEZAS

NOTA: Vista para montagem das gavetas para sua ESQUERDA

NOTE: View of assembly of drawers to your LEFT

NOTA: Vista de conjunto de cajones a tu IZQUIERDA

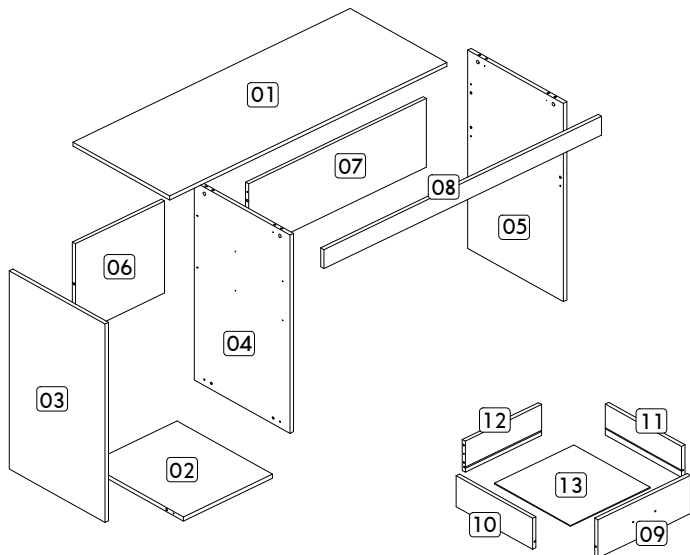

NOTA: Vista para montagem das gavetas para sua DIREITA

NOTE: View of assembly of drawers to your RIGHT

NOTA: Vista de conjunto de cajones a tu DERECHA

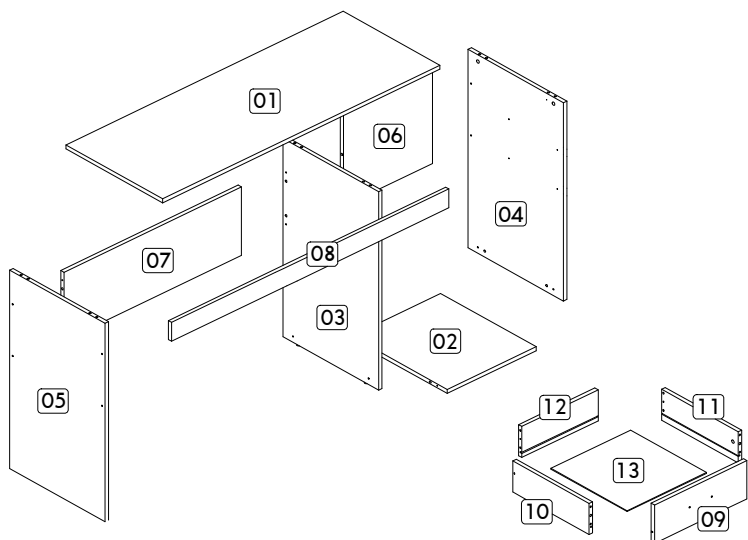

Nº	DESCRIÇÃO - DESCRIPTION - DESCRIPCIÓN	MEDIDAS-MEASURES - MEDIDAS (mm)	QTD.
01	Base superior - Top base - Base superior	1200 x 450 x 15	01
02	Base inferior - Bottom base - Base inferior	385 x 445 x 15	01
03	Lateral esquerda - Left side - Lateral izquierda	740 x 445 x 15	01
04	Divisão - Division - División	740 x 445 x 15	01
05	Lateral direita - Right side - Lateral derecha	740 x 445 x 15	01
06	Costa esquerda - Left back - Fondo izquierdo	341 x 385 x 15	01
07	Costa direita - Right back - Fondo derecho	254 x 767 x 15	01
08	Vista frontal - Front frame - Moldura el frente	1200 x 70 x 15	01
09	Frente de gaveta - Drawer front - Frente del cajón	400 x 142 x 15	02
10	Lateral de gaveta esquerda - Left side of drawer - Lateral izquierda del cajón	355 x 115 x 15	02
11	Lateral de gaveta direita - Right side of drawer - Lateral derecha del cajón	355 x 115 x 15	02
12	Traseiro de gaveta - Rear of drawer - Trasero del cajón	330 x 115 x 15	02
13	Fundo de gaveta - Bottom of drawer - Fondo del cajón	344 x 354 x 03	02

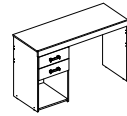

NOTA: Se optou por montar as gavetas para a direita, vá para a página 8
NOTE: If you chose to install the drawers to the right, go to page 8
NOTA: Si elegiste instalar los cajones a la derecha, ir a la página 8

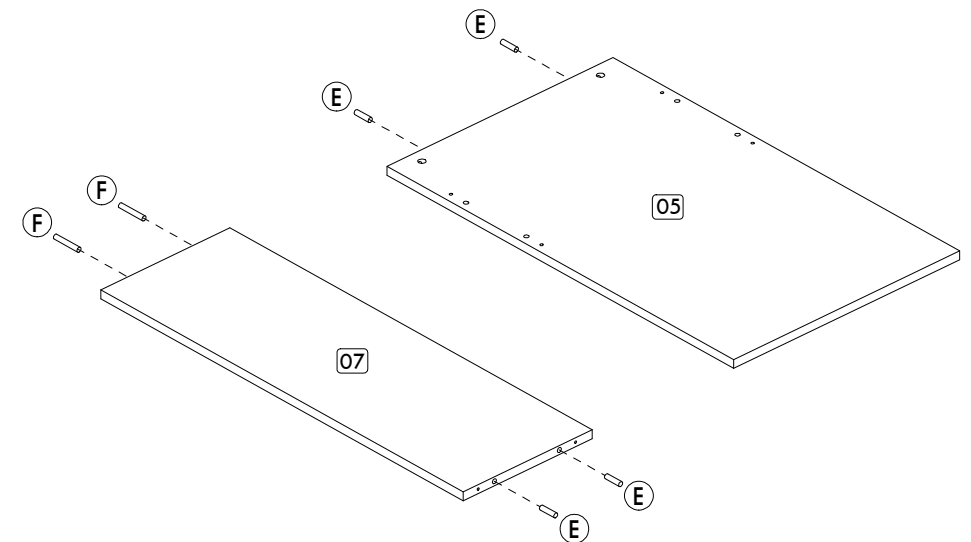
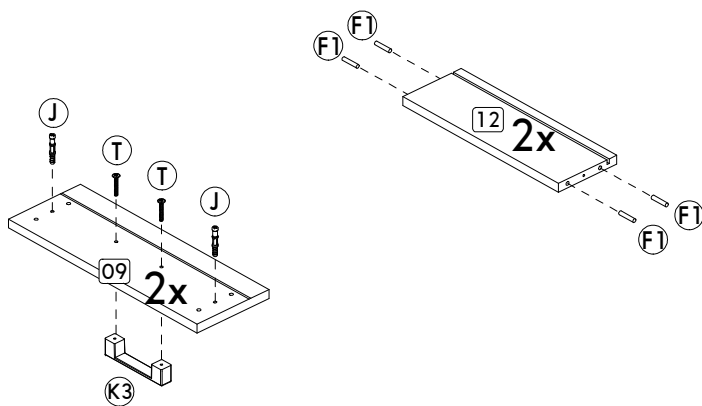
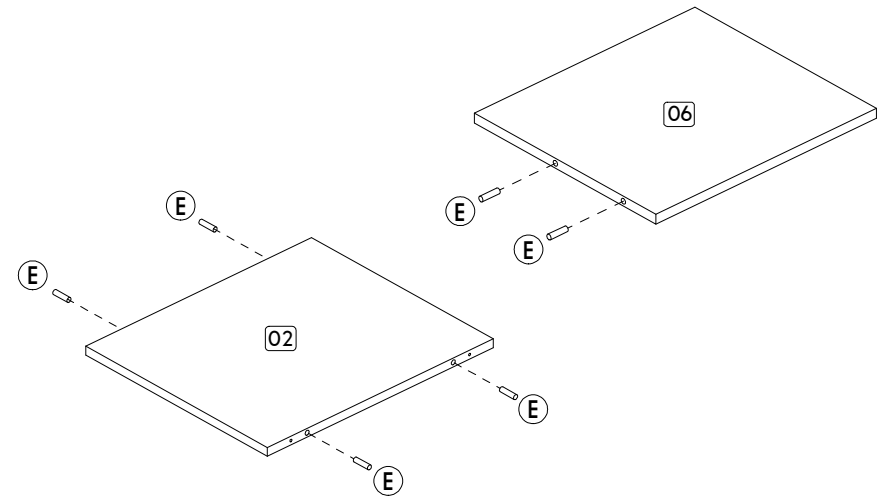
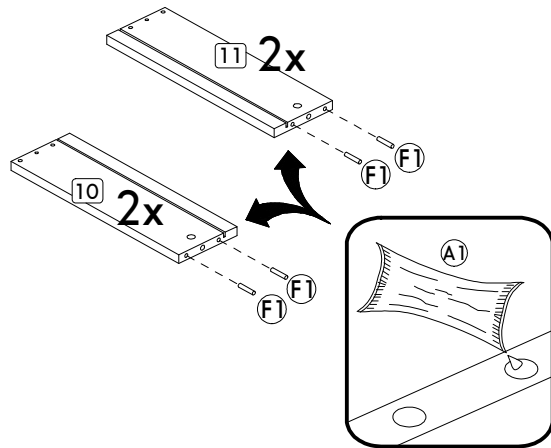

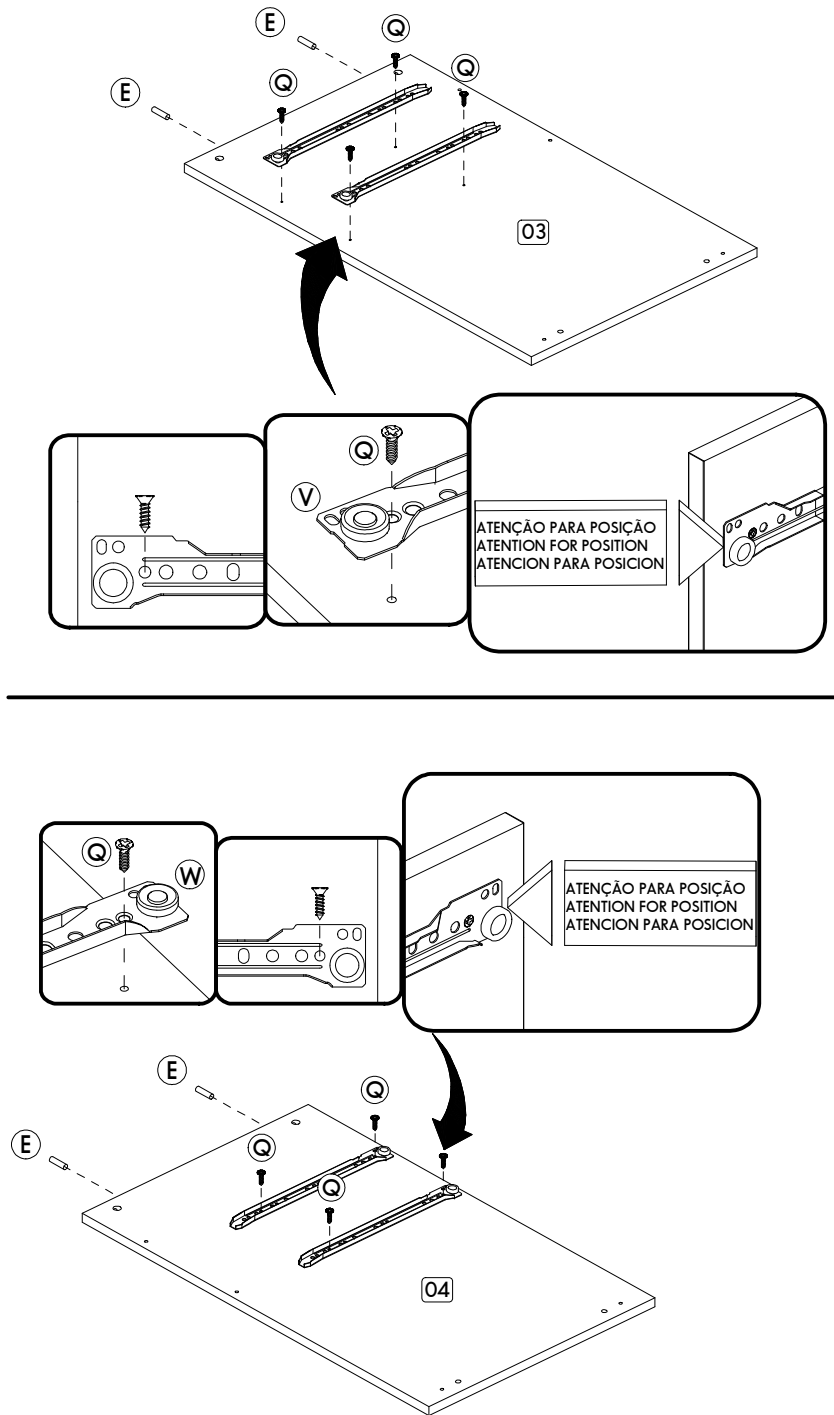
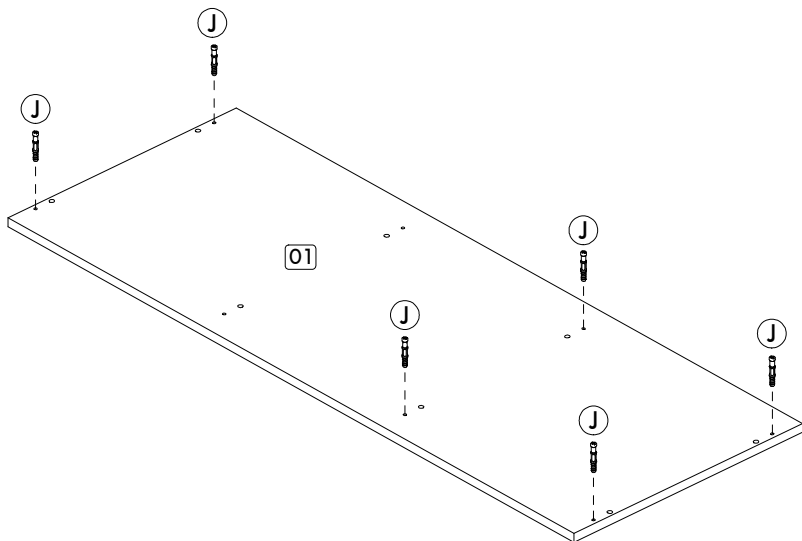
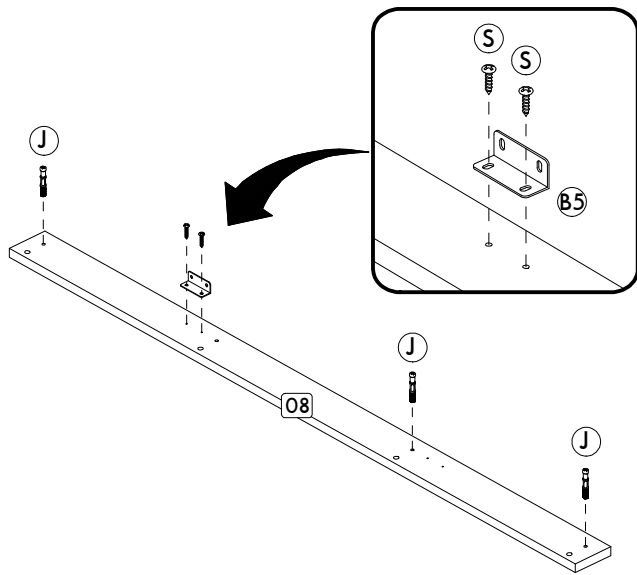

Passo/ Step/ Paso **01**

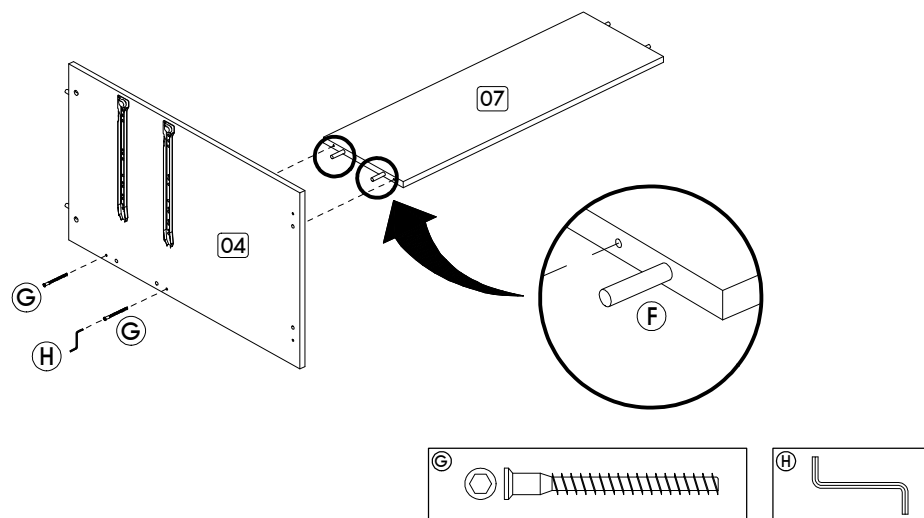

Passo/ Step/ Paso **02**

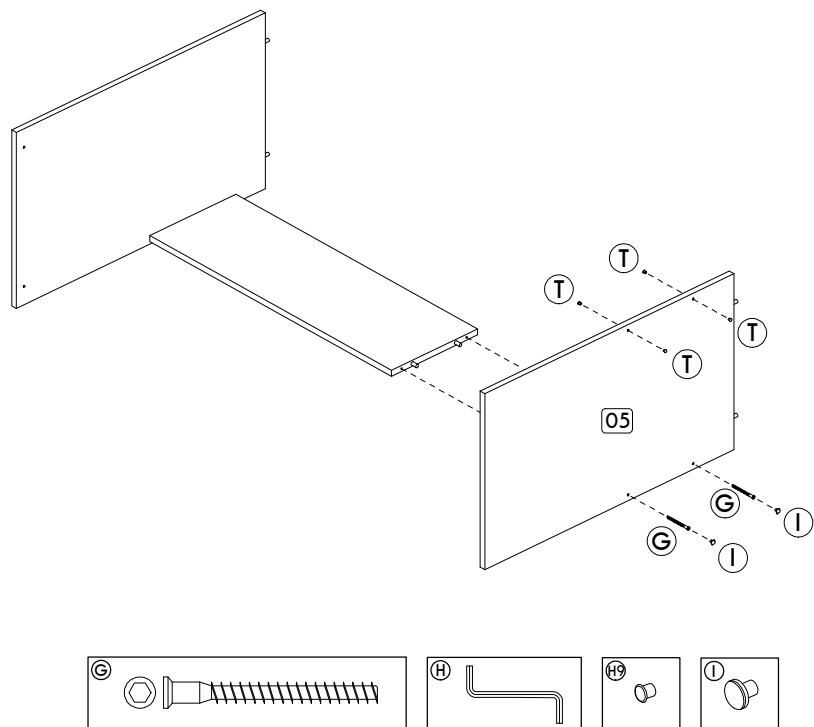

Passo/ Step/ Paso **03**

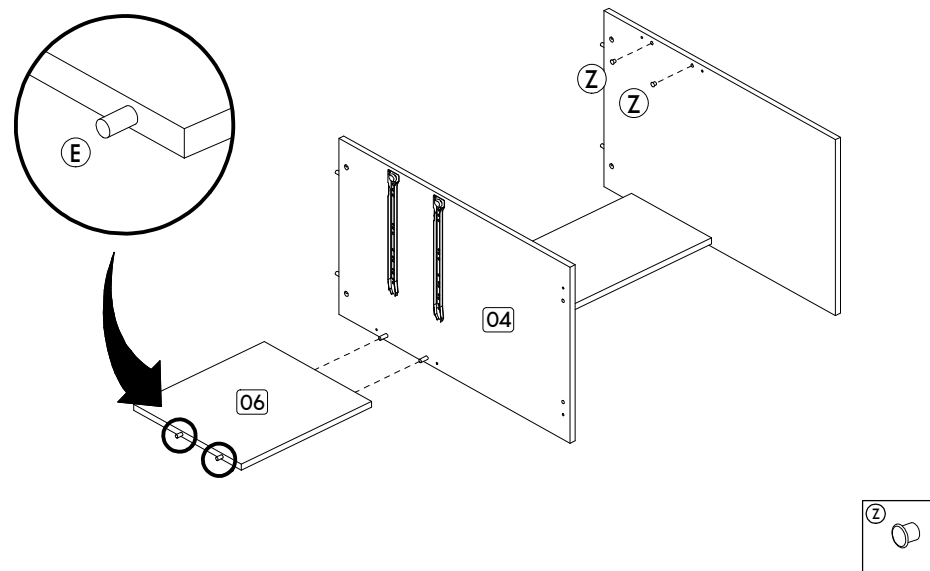

Passo/ Step/ Paso **04**

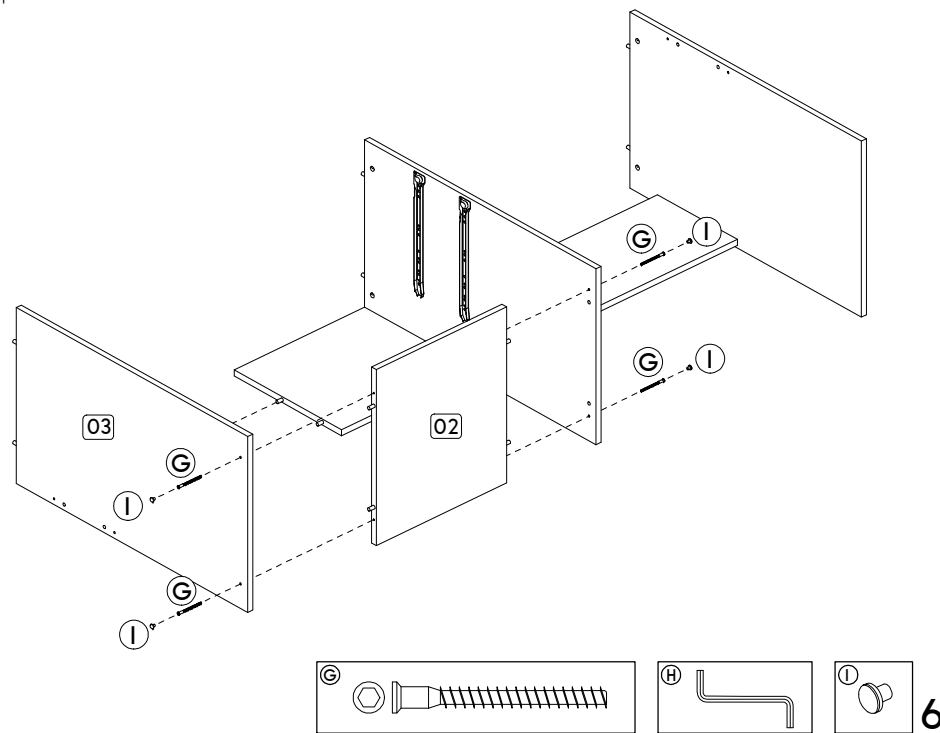

Passo/ Step/ Paso 05

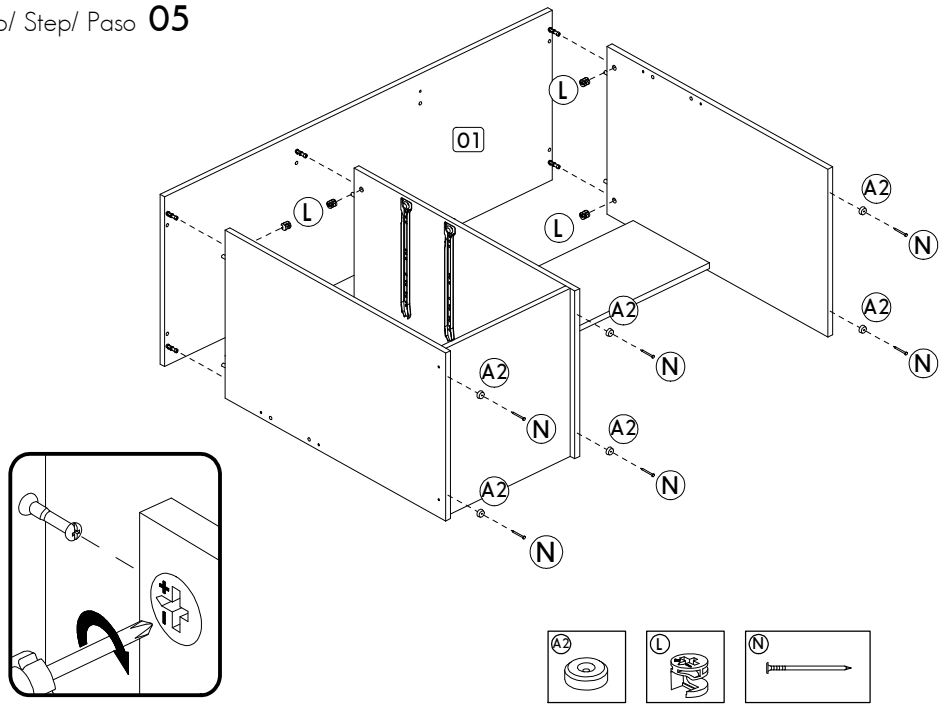

Passo/ Step/ Paso 06

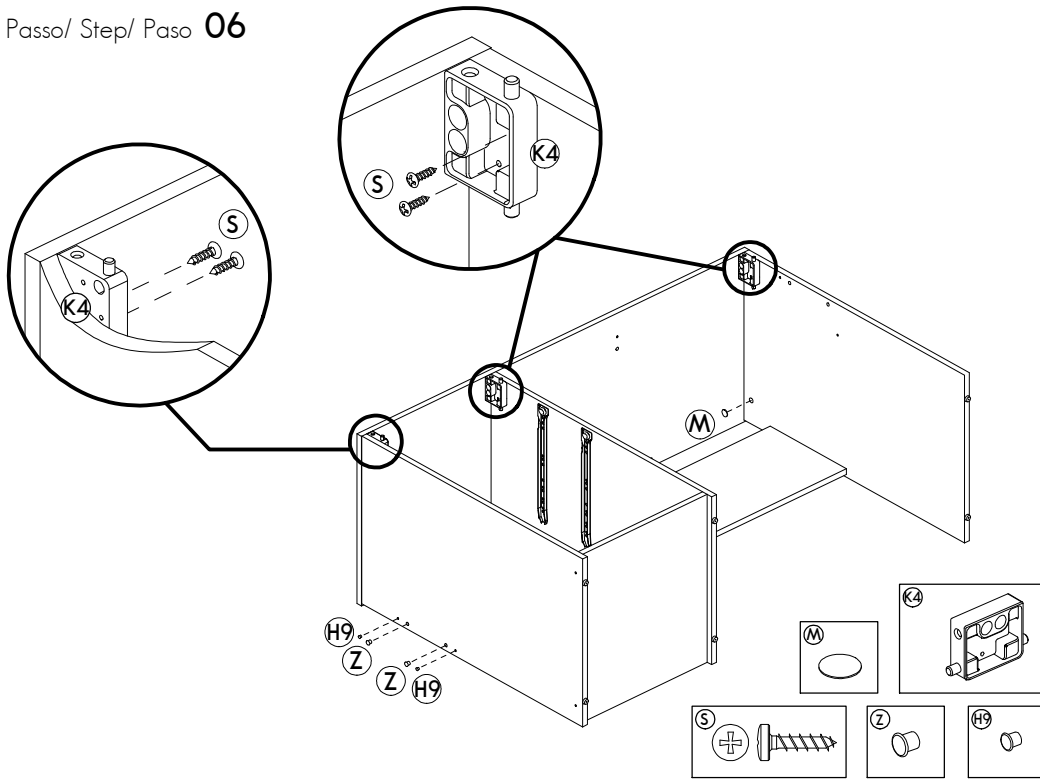

Passo/ Step/ Paso 07

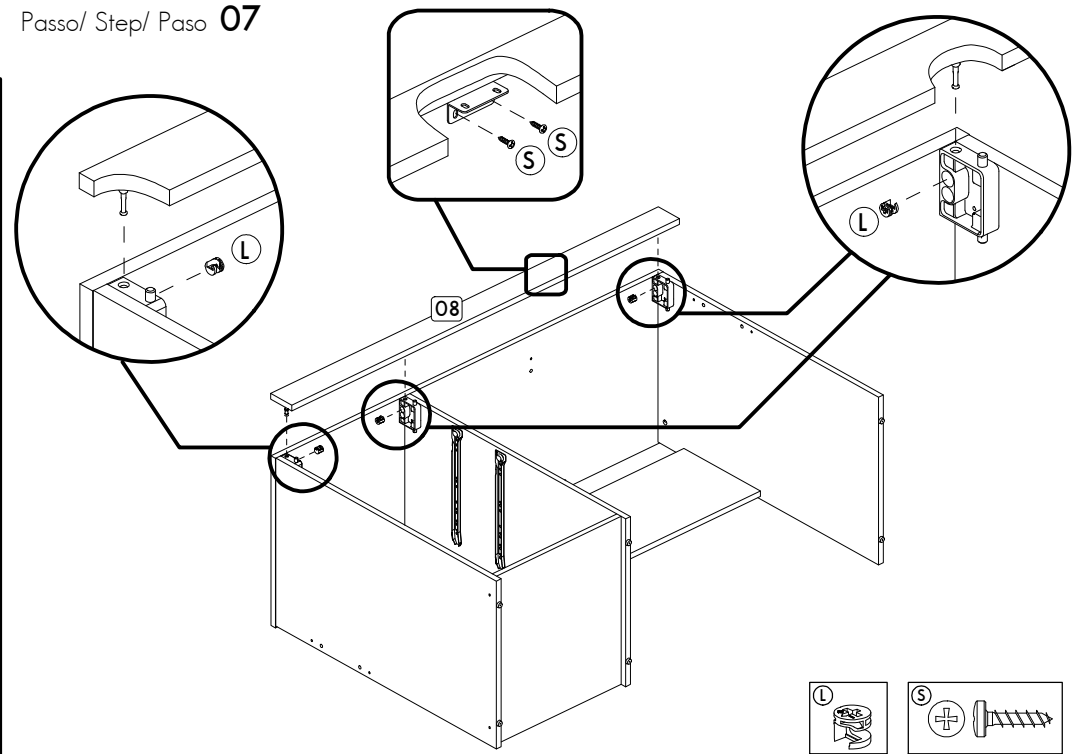

Passo/ Step/ Paso 08

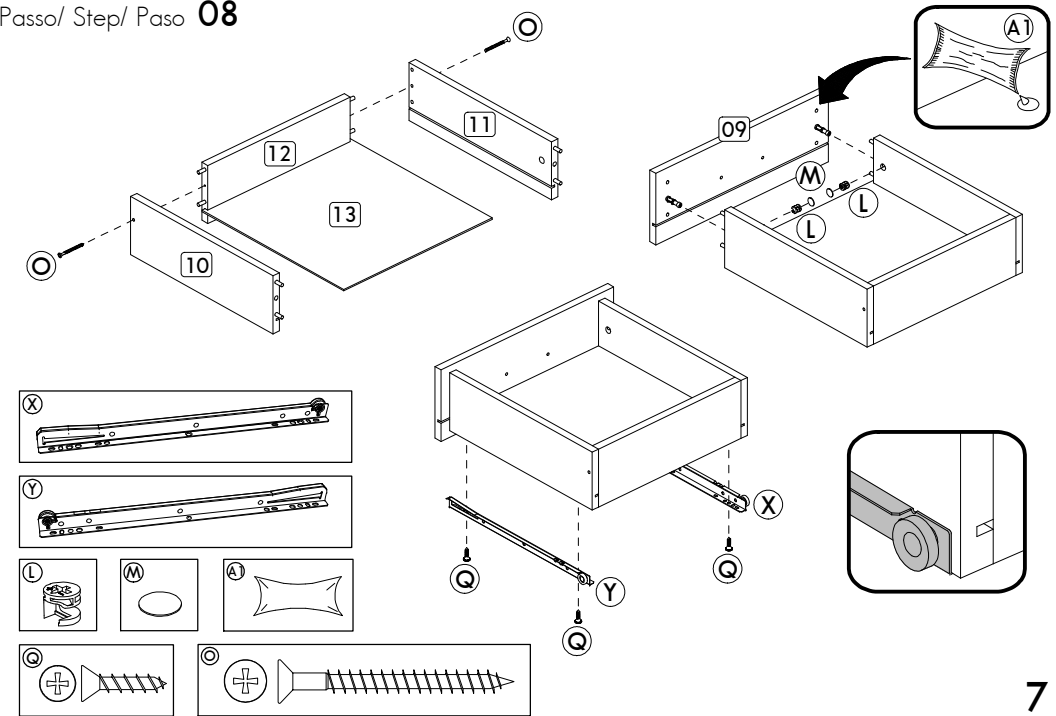

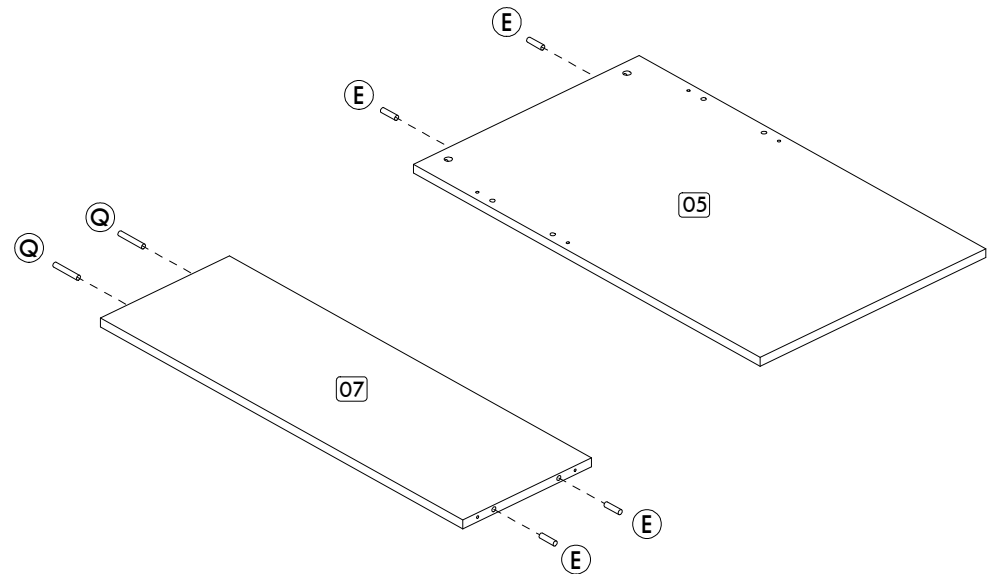
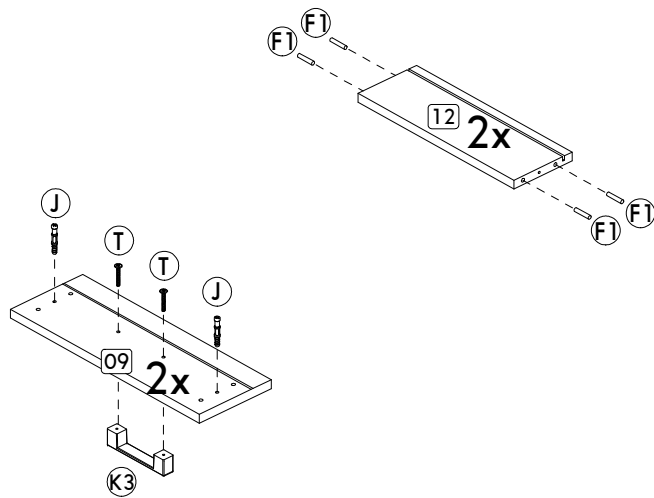
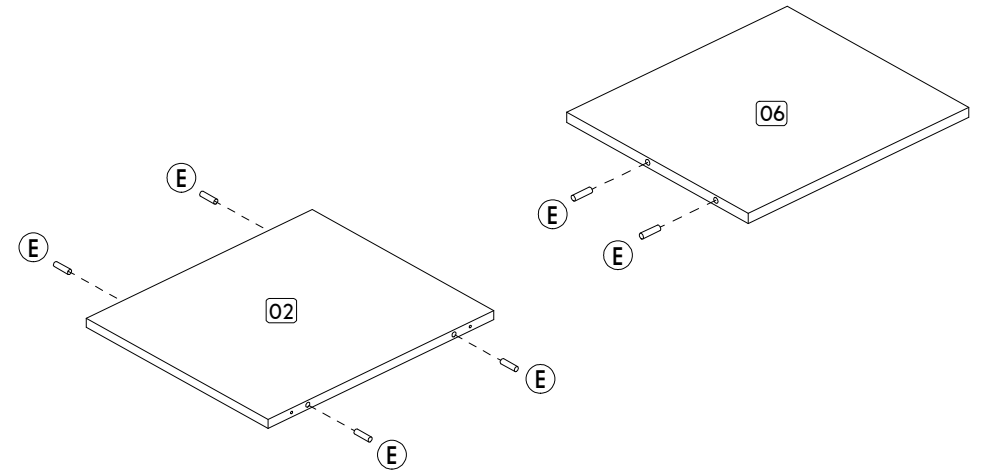
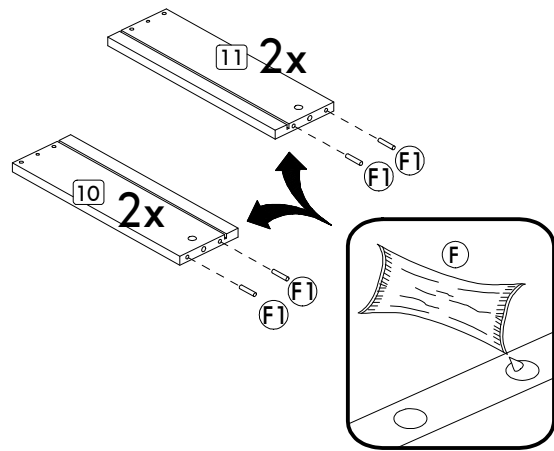
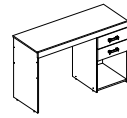

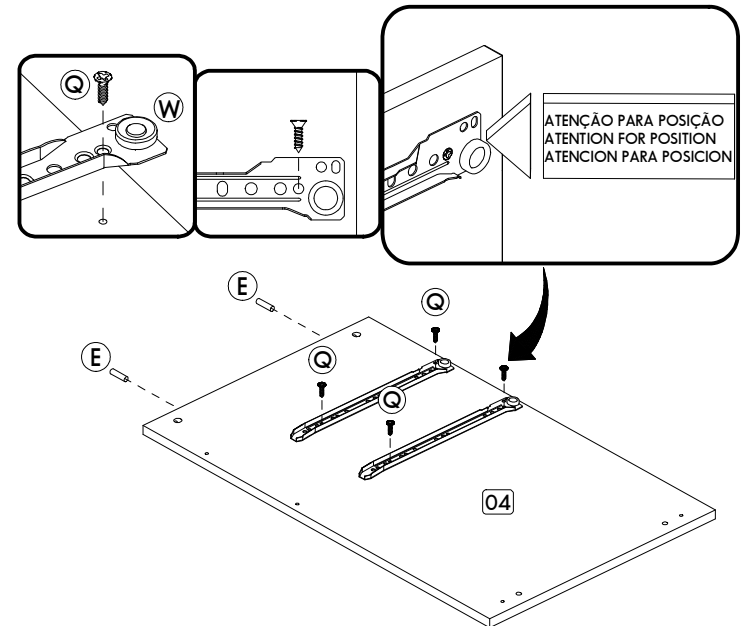
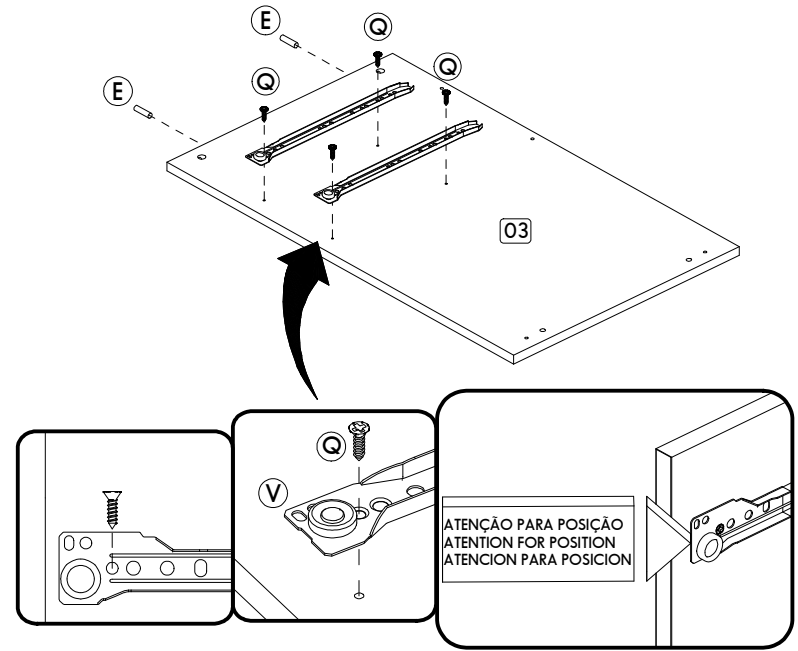
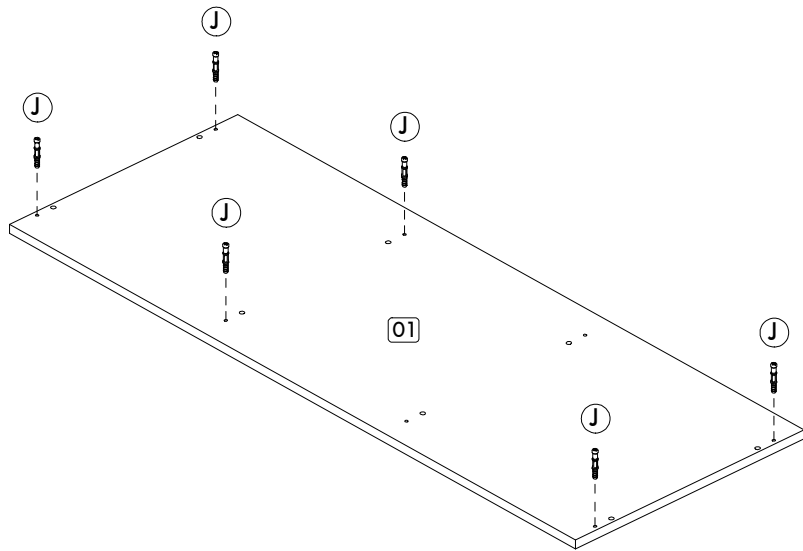
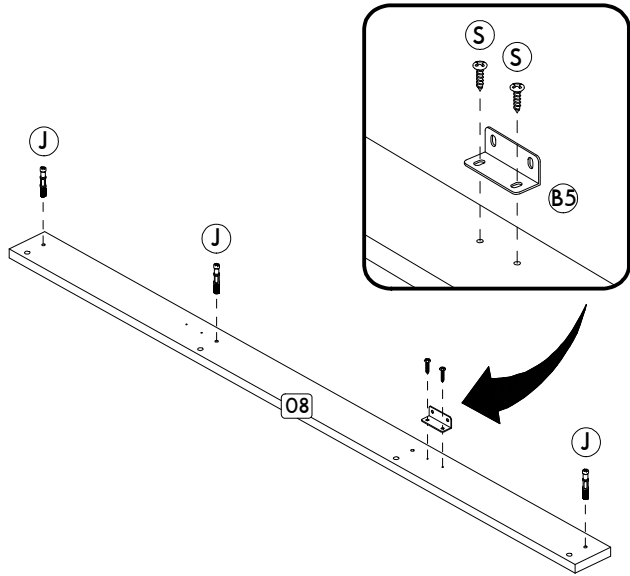

Passo/ Step/ Paso **01**

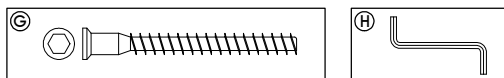
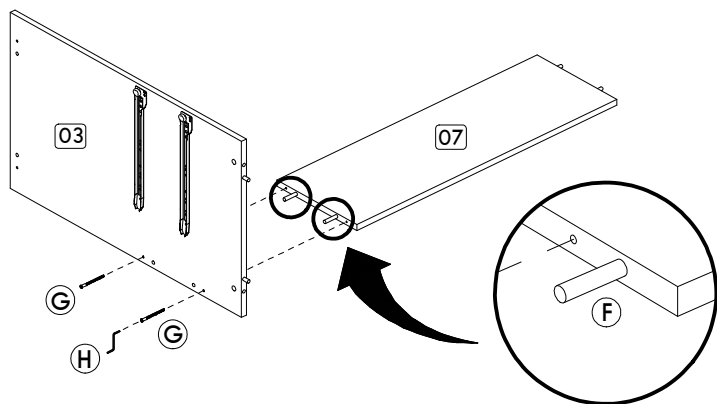

Passo/ Step/ Paso **02**

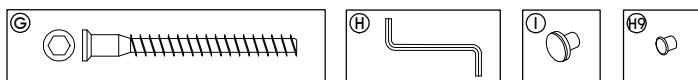
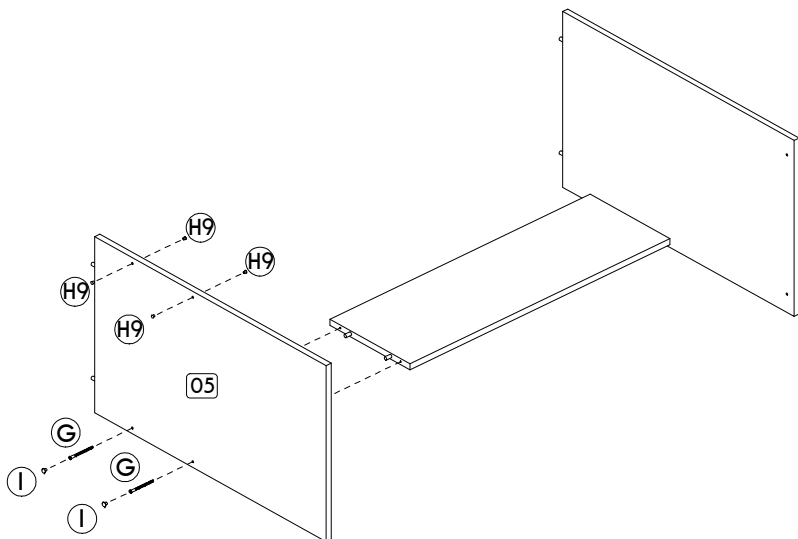

Passo/ Step/ Paso **03**

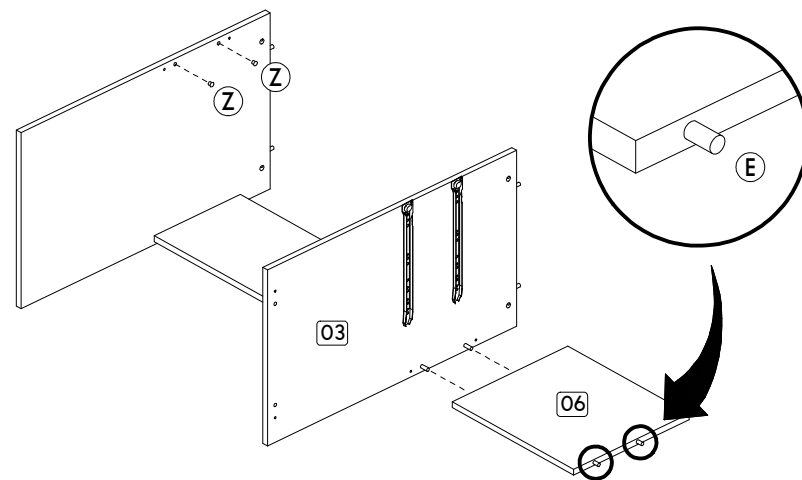

Passo/ Step/ Paso **04**

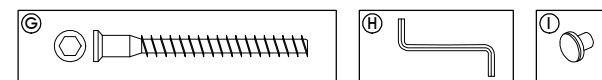
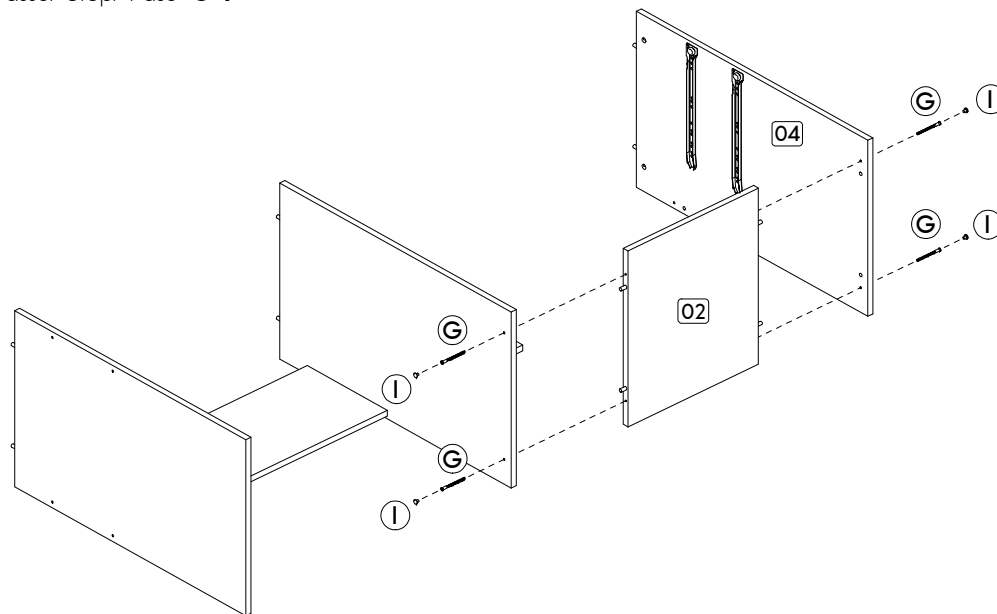

Passo/ Step/ Paso 05

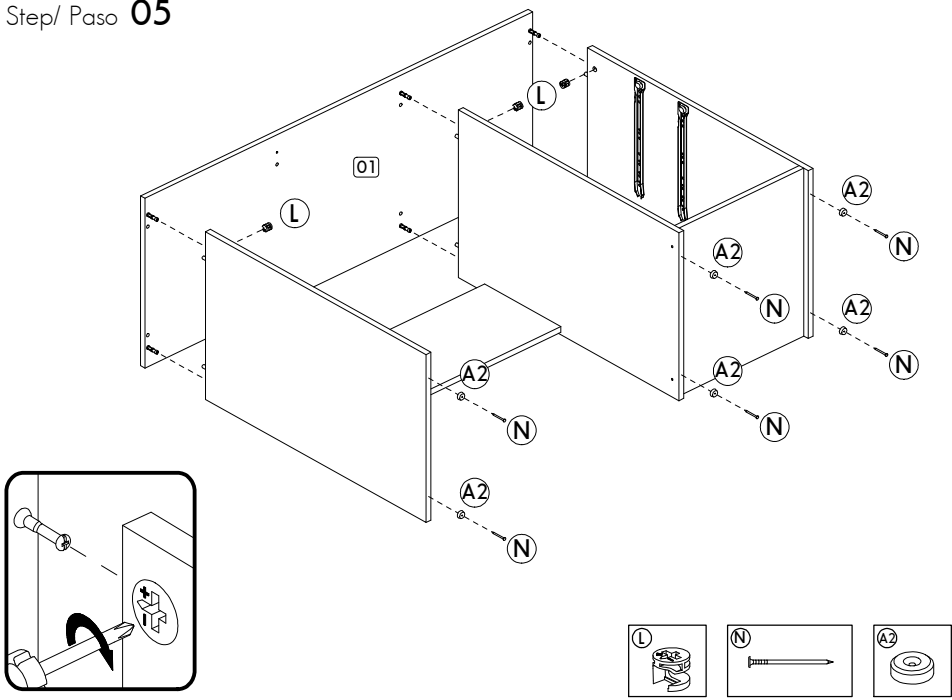

Passo/ Step/ Paso 06

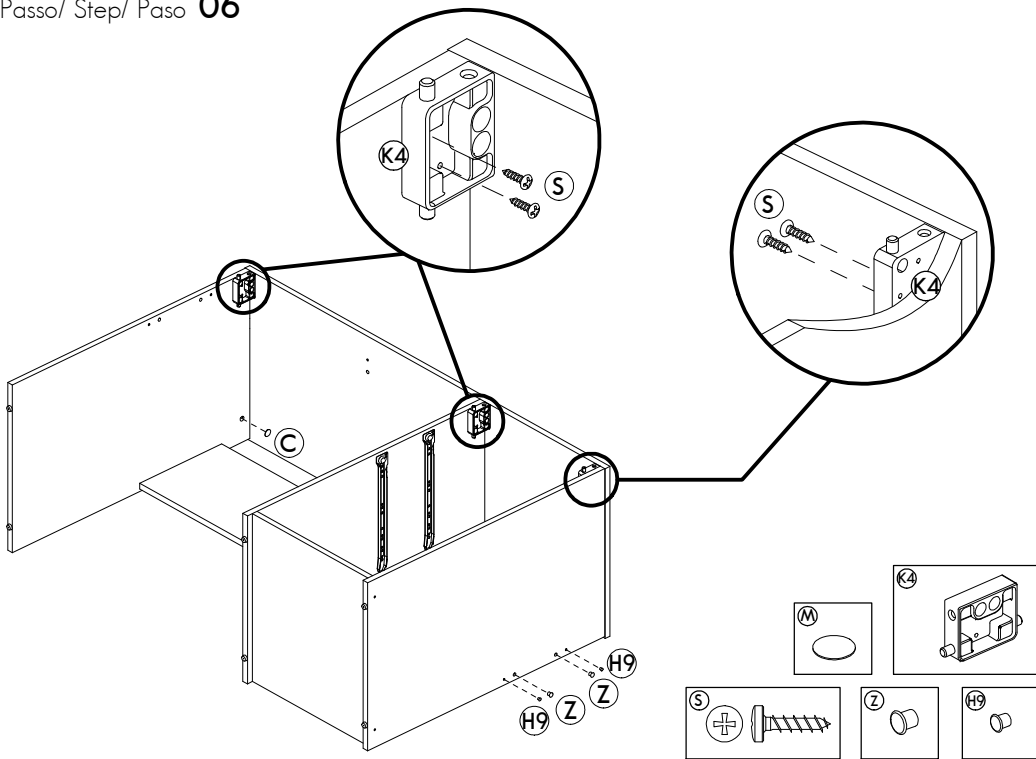

Passo/ Step/ Paso 07

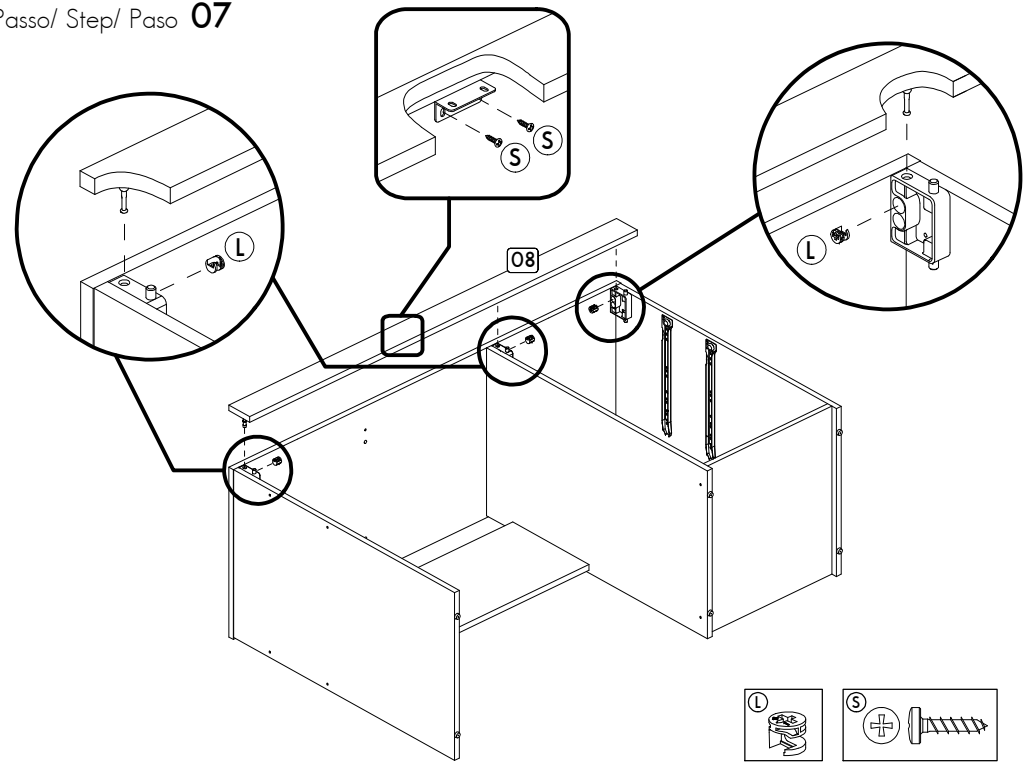

Passo/ Step/ Paso 08

