

Item	Caixa Caja Box	Qtd Ctd Qty	Descrição Descripción Description	Medidas (mm) Dimensions (mm) Size (measurements) (mm)
01	1/1	01	Rodapé Frontal Frente pie de página Front Footer	1200x145x15
02	1/1	02	Rodapé Lateral Pie de página Side Side Footer	450x145x15
03	1/1	01	Rodapé Traseiro Pie de página trasera Rear Footer	1168x145x15
04	1/1	01	Base Base Base	1200x490x15
05	1/1	01	Lateral esquerda Lateral izquierda Left side	660x490x15
06	1/1	01	Divisão División Division	600x490x15
07	1/1	01	Prateleira Estante Shelf	784x400x15
08	1/1	01	Lateral direita Lateral derecha Right side	660x490x15
09	1/1	01	Travessa frontal Travesaño frontal Front crossbar	1169x60x15
10	1/1	01	Travessa traseira Travesaño trasero Rear bumper	1169x60x15
11	1/1	01	Pilastra da Porta Pilastra Puerta Pilaster door	599x60x15
12	1/1	01	Fundo Lateral Fondo Lateral Lateral Background	683x389x3
13	1/1	02	Fundo Fondo Bottom	803x341x3
14	1/1	02	Porta Puerta Door	665x396x15
15	1/1	03	Frente de gaveta Frente de cajón Front of drawer	396x220x15
16	1/1	06	Lado de Gaveta Lado del cajón Drawer Side	400x122x15
17	1/1	03	Fundo de gaveta Fondo de cajón Bottom of drawer	411x326x3
18	1/1	03	Ripa de trás Malla detrás Rear lath	345x122x15



Ind. e Com. de Móveis Henn
Mondai - SC - Brasil

+55 49 3674.3500

@moveishenn
www.henn.com.br

INSTRUÇÕES DE MONTAGEM

INSTRUCCIONES DE MONTAJE
ASSEMBLY INSTRUCTIONS

Balcão Pia 03 Gavetas 02 Portas Americana
Pia Contador 03 Cajones 02 Puertas Americana | Balcony Pia 03 Drawers 02 Doors Americana
C353-05 Branco HP

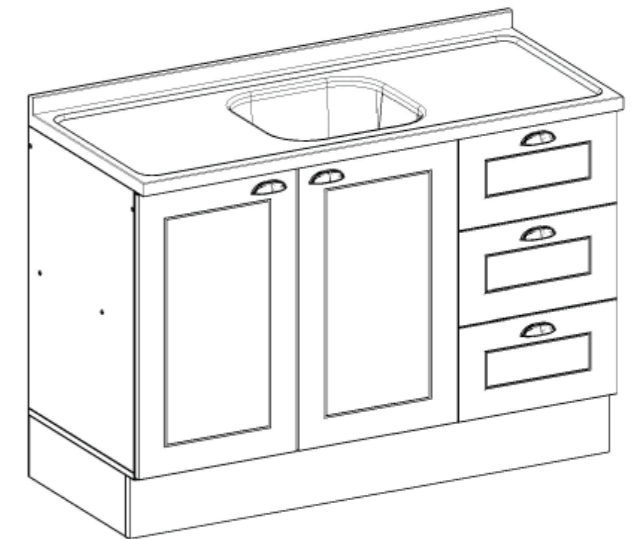
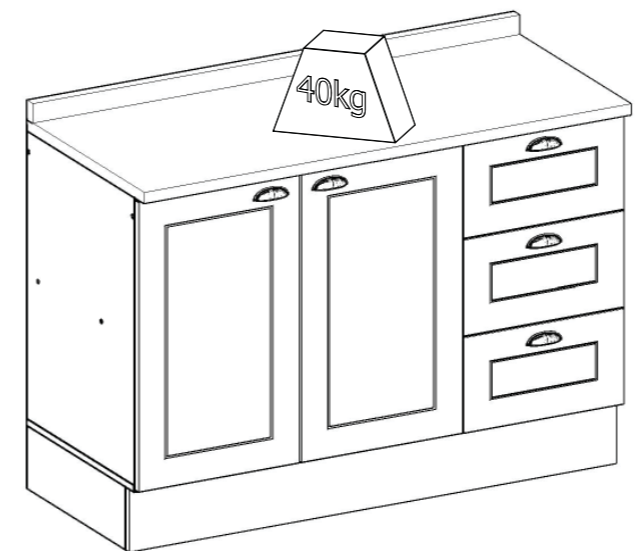
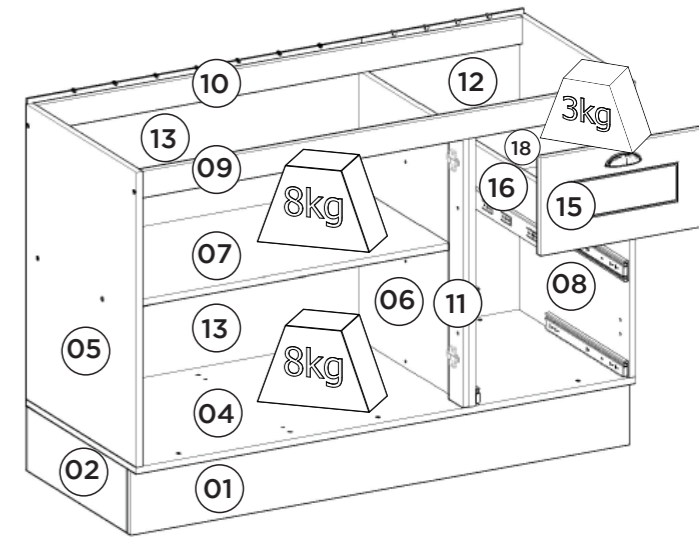
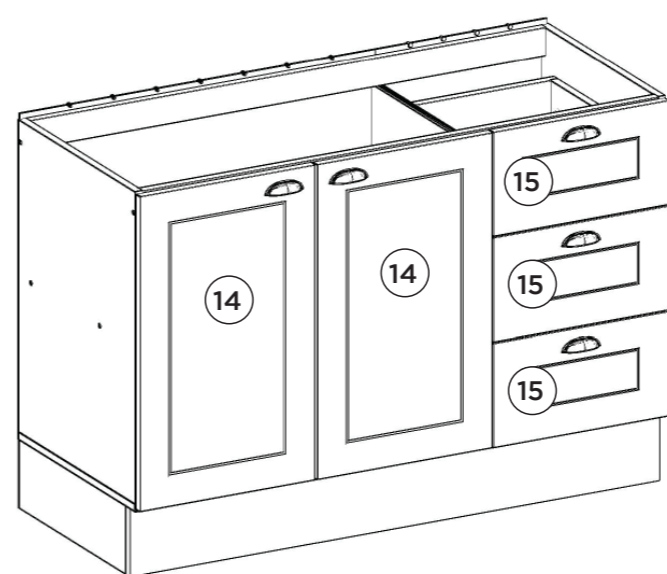

Pesos máximos recomendados com carga distribuída
Peso máximo recomendado con la carga distribuida
Recommended maximum weights with evenly distributed.

Ferragens | Herrajes | Hardware

A 03x Parafuso 5,0x50mm FLA. Tornillo 5,0x50mm FLA. Screw 5,0x50mm FLA.	B 04x Parafuso 4,5x50mm CHT. Tornillo 4,5x50mm CHT. Screw 4,5x50mm CHT.	C 02x Parafuso 4,0x25mm CHT. Tornillo 4,0x25mm CHT. Screw 4,0x25mm CHT.	D 20x Parafuso 3,5x40mm CHT. Tornillo 3,5x40mm CHT. Screw 3,5x40mm CHT.	E 52x Parafuso 3,5x14mm FLA. Tornillo 3,5x14mm FLA. Screw 3,5x14mm FLA.	F 51x Parafuso 3,5x12mm CHT. Tornillo 3,5x12mm CHT. Screw 3,5x12mm CHT.
G 10x Parafuso M4x20mm CHT. ZB Tornillo M4x20mm CHT. ZB Screw M4x20mm CHT. ZB	H 52x Cavilha 8x25mm Cinta 8x25mm Dowel 8x25mm	I 06x Prego 12x12mm Anelado Clavo 12x12mm Anillado Ringed Nails 12x12mm	J 38x Prego 10x10mm Clavo 10x10mm Nail 10x10mm	K 13x Fixador de fundos Fijador de fondos Bottom fixer	L 11x Cantoneira plástica Cantoneira plástica Plastic angle brackets
M 12x Parafuso minifix Tornillo minifix Minifix bolt	N 12x Tambor minifix Tambor minifix Minifix drum	O 05x Puxador Concha Tirador Concha Shell Handle	P 06x Parafuso União 30mm Tornillo Unión 30mm Union Screw 30mm	Q 04x Calço Removível Calzado extraíble Removable Shim	R 04x Dobradilha SlideOn Baja Amortiguación 35mm Bisagra SlideOn Baja Amortiguación 35mm Low Damping hinge SlideOn 35mm
S 03x Corrediça telescópica Diapositivas telescópicas Telescopic slides	T 01x Porta detergente 256x91mm Puerta detergente 256x91mm Detergent door 256x91mm	U 01x Divisor talheres 398x313mm Divisor cubiertos 398x313mm Cutlery divider 398x313mm	V 03x Bucha plástica 8mm Bucha de plástico 8mm 8mm plastic bushing	W 03x Suporte de fixação Soporte de fijación Mounting bracket	X 03x Proteção para cantoneira Ángulo de protección Protection angle
Y 06x Sapata "L" 16x20mm Zapata "L" 16x20mm "L" shoe 16x20mm	Z 02x Sachê de cola Bolsa de pegamento Glue bag	AA 02x Giz de correção Tiza de corrección Chalk of correction	AB 06x Adesivo tapa parafuso 17mm Adhesivo tapón de tornillo 17mm Bolt cover adhesive 17mm	AC 26x Adesivo tapa parafuso 10mm Adhesivo tapón de tornillo 10mm Bolt cover adhesive 10mm	AD 01x Etiqueta resinada Henn Etiqueta resinada Henn Henn resin label

Requisitos para montagem
Requisitor para la montaje
Assembly Requirements

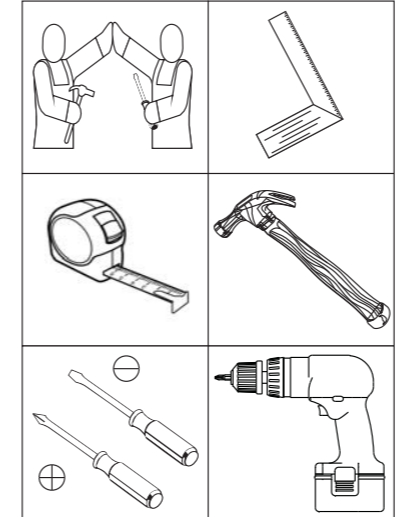

Imagens meramente ilustrativas
Imágenes meramente ilustrativas
Images for illustration only

O parafuso (P) deve ser usada somente quando este módulo for acoplado a outro módulo componível Henn.

El tornillo (P) se debe utilizar sólo cuando el módulo está conectado a otro módulo componible Henn.

The screw (P) should be used only when this module is attached to another Henn modular module.

RECOMENDAÇÃO
Para fixar o móvel na parede usar o suporte de fixação (W), o parafuso 3,5x14mm FLA (E), a Bucha 8mm (V) e o parafuso 5,0x50mm FLA (A).

RECOMENDACIÓN
Para conectar el móvil a la pared con el soporte (W), tornillo 3,5 x14mm FLA (E), el casquillo de 8 mm (V) y el 5,0 x50mm tornillo FLA (A).

RECOMMENDATION
To fix the furniture to the wall use the mounting bracket (W), the 3.5x14mm FLA (E) screw, the 8mm bushing (V) and the 5.0x50mm FLA screw (A).

AVISO
Para limpeza de seu móvel, use uma flanela seca ou umedecida, e não utilize produtos químicos que possam danificar seu produto.

SISTEMA DE MONTAGEM
O sistema de montagem dos produtos, funciona de acordo com a ordem crescente dos números indicados no desenho. Ex: 01, 02, 03, 04... até a conclusão da montagem.

ADVERTENCIA
Para limpieza de su móvil, use una flanela seca o húmeda, y no utilice productos químicos que puedan dañar su producto.

SISTEMA DE MONTAJE
El sistema de montaje de los productos funciona de acuerdo con el orden creciente de los números indicados en el dibujo. Ej.: 01, 02, 03, 04... hasta la conclusión del montaje.

NOTICE
To clean your furniture, use a dry or wet cloth, and do not use chemicals that may damage your product.

ASSEMBLY SYSTEM
The products' assembly system works according to the increasing order of the indicated numbers. For example: 01, 02, 03, 04 ... to the end of the assembly.

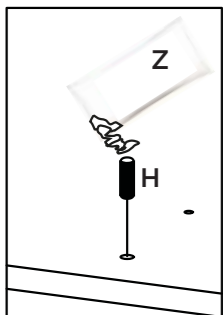
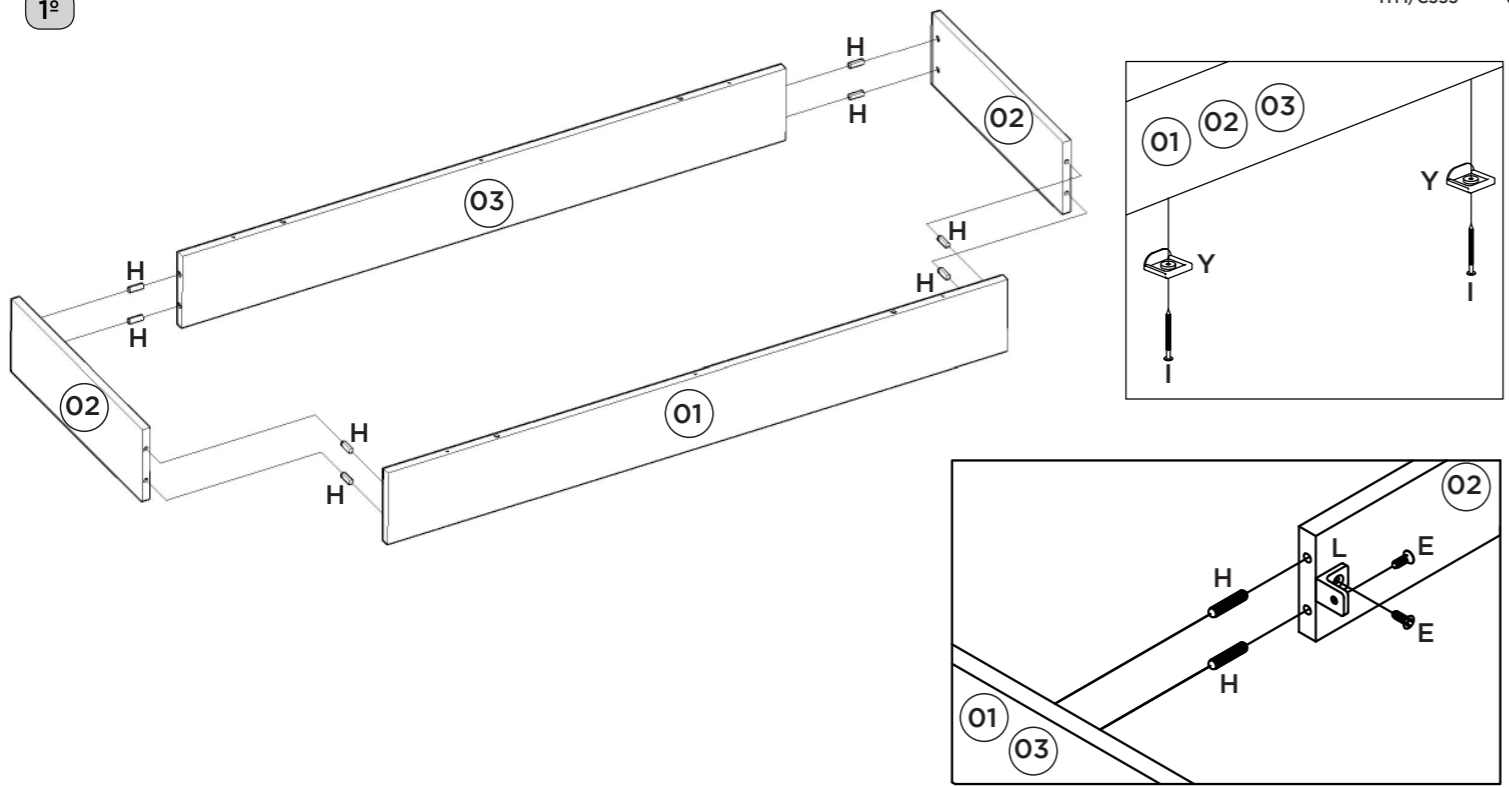

Utilizar o sachê de cola (Z) em todas as cavilhas (H) do produto.

Con el pegamento sobre (Z) en todos los pernos (H) producto.

Use the glue sachet (Z) on all the pegs (H) of the product.

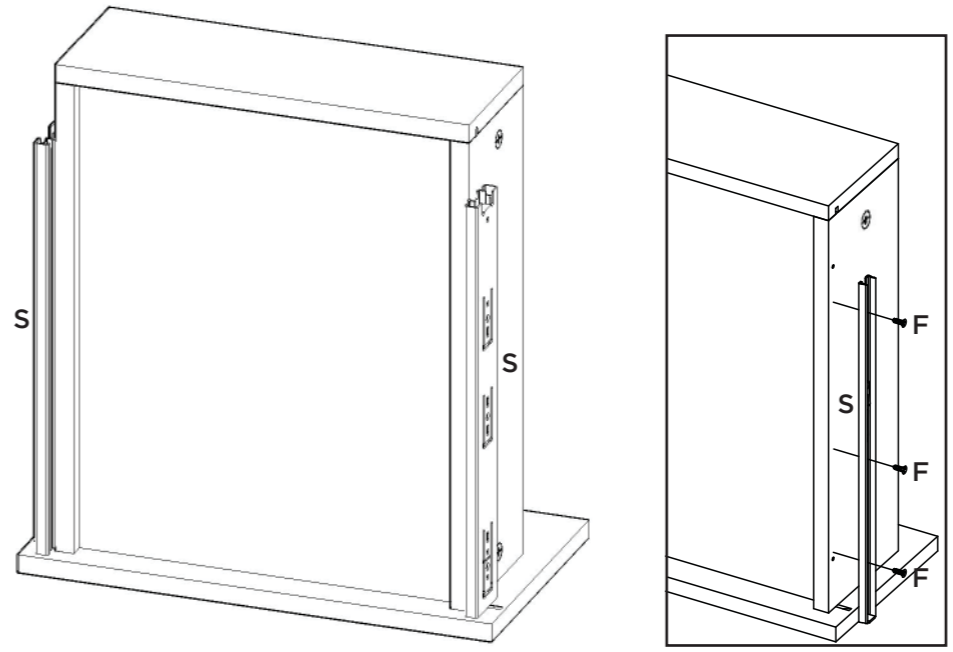
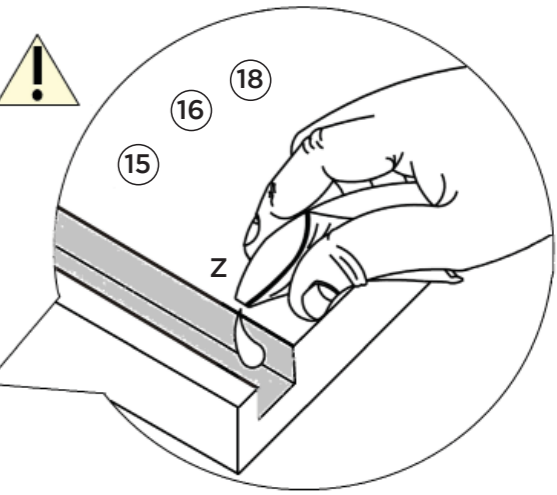
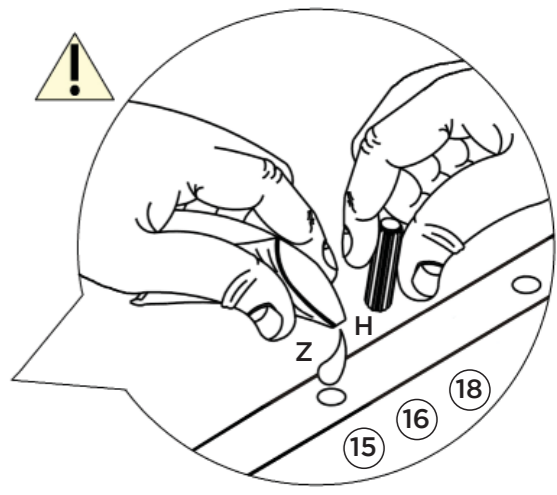
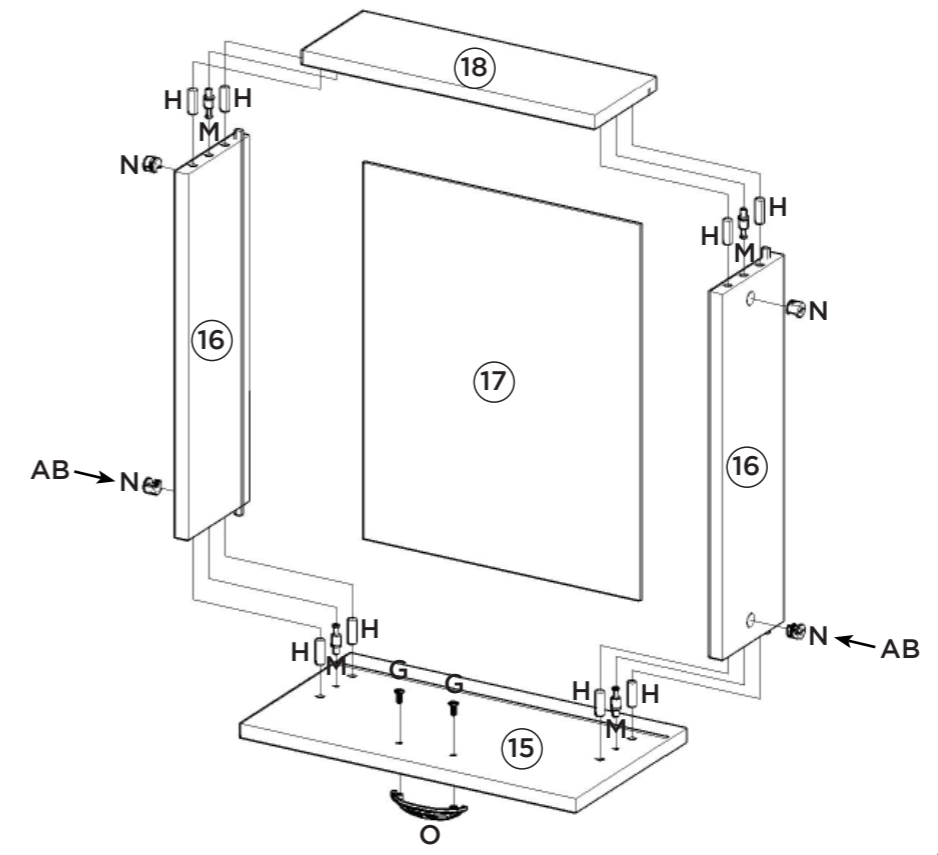
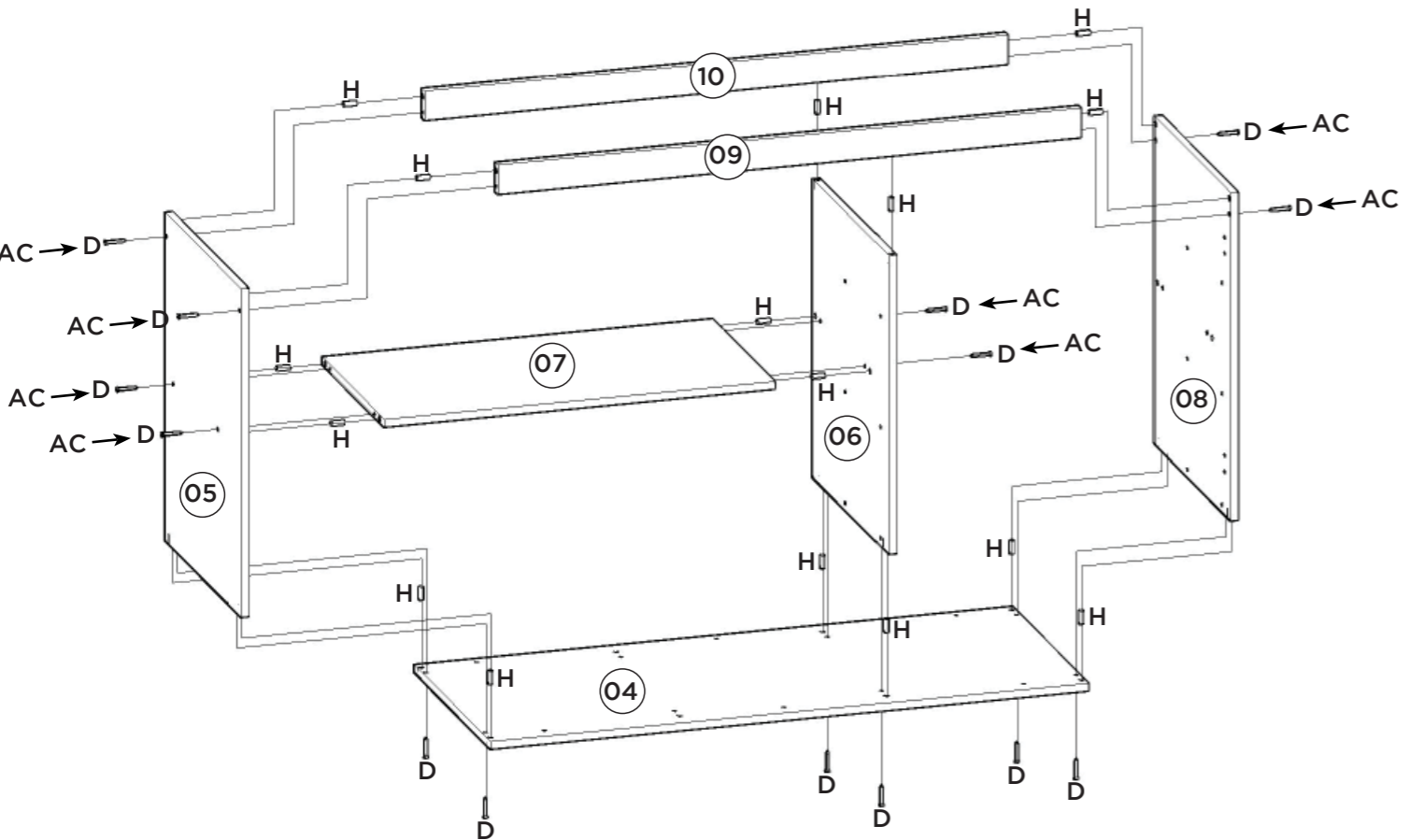

A corredeira (S) deverá ser alinhada com a parte de baixo do lado de gaveta (16).

La carcasa (S) será alineada con la parte de por el lado del cajón (16).

The slide (S) should be aligned with the underside of the drawer side (16).

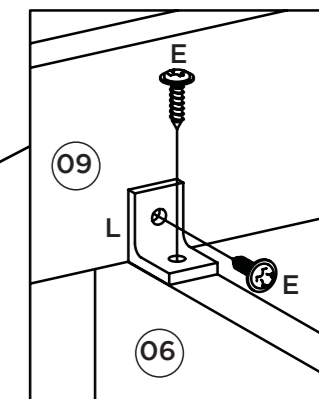
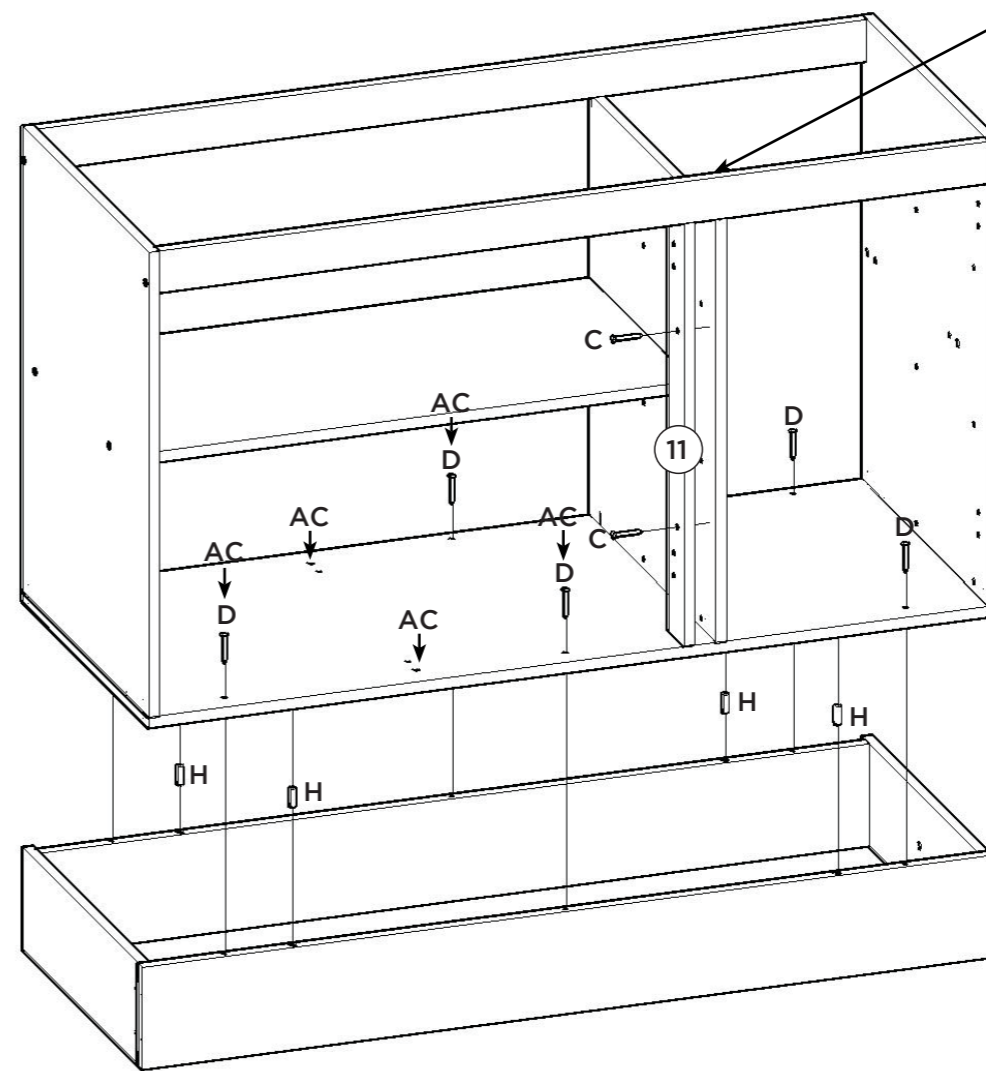
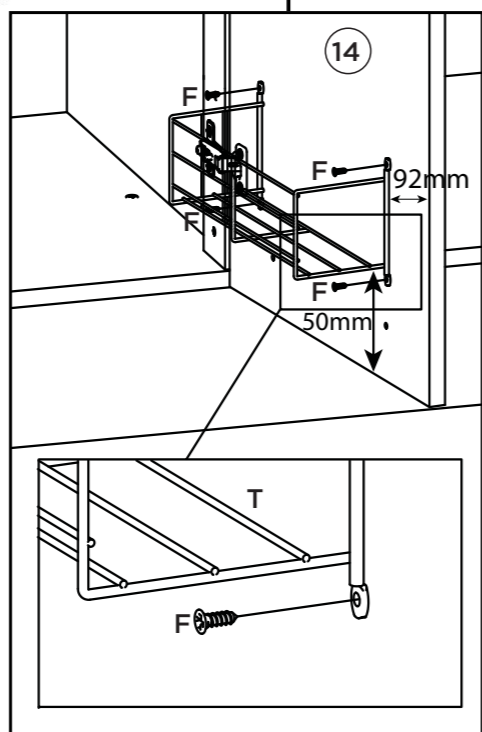
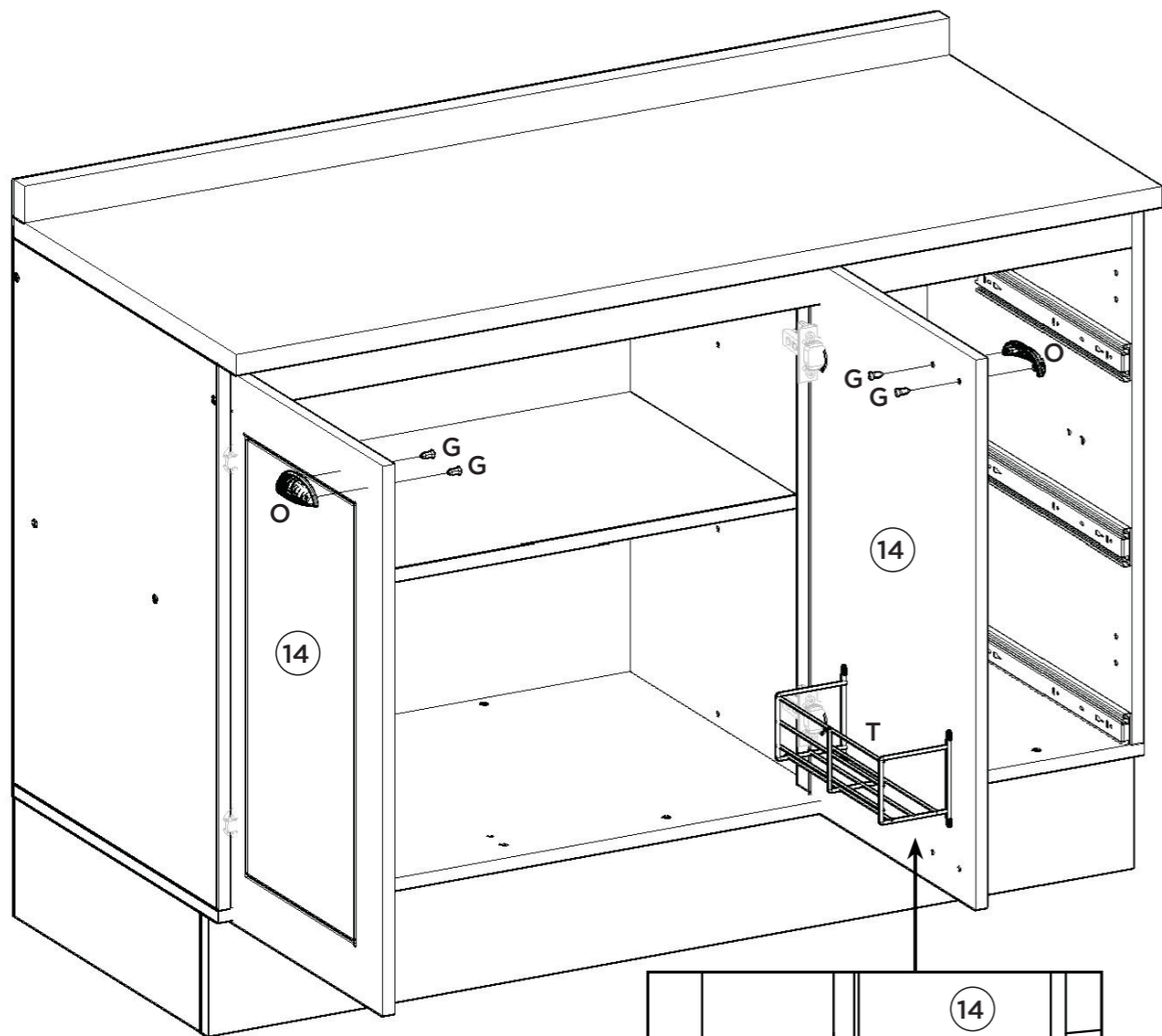
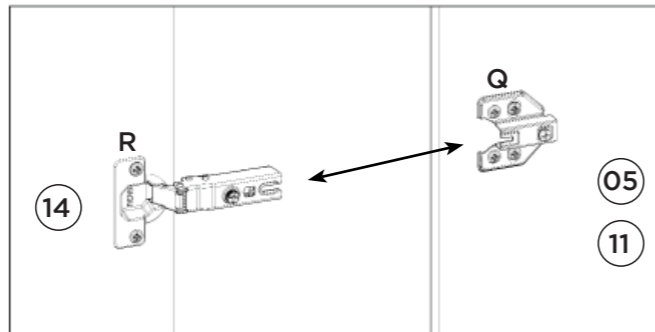
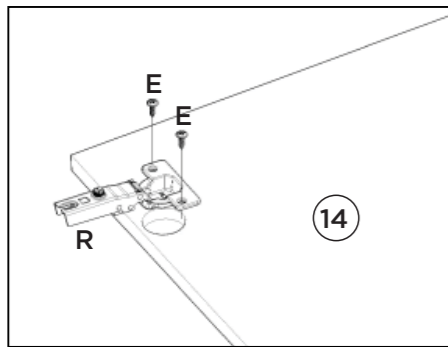

A pilastra da porta (11) deve estar alinhada com a divisão (06).

El pilar de la puerta (11) debe estar alineada con la división (06).

The door pillar (11) must be aligned with the partition (06).

Esse tampo é opcional e é vendido separadamente (C905-114).

Esta vez es opcional y se vende por separado (C905-114).

This top is optional and is sold separately (C905-114).

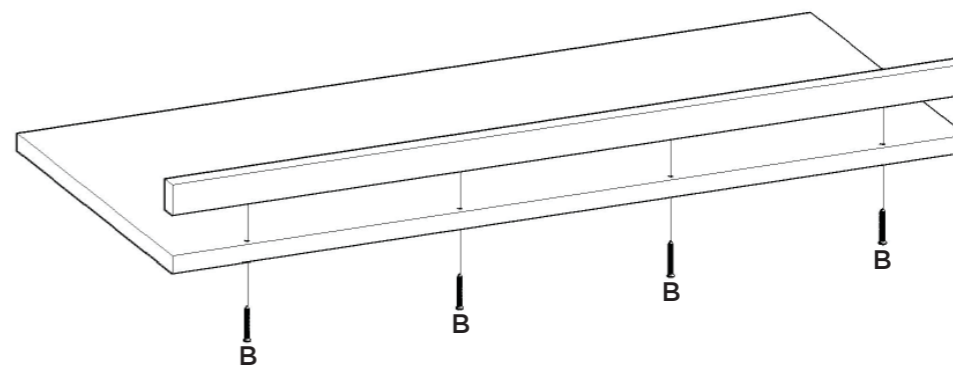

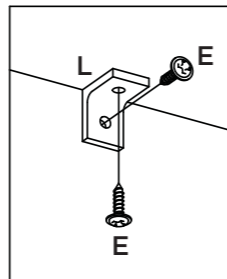
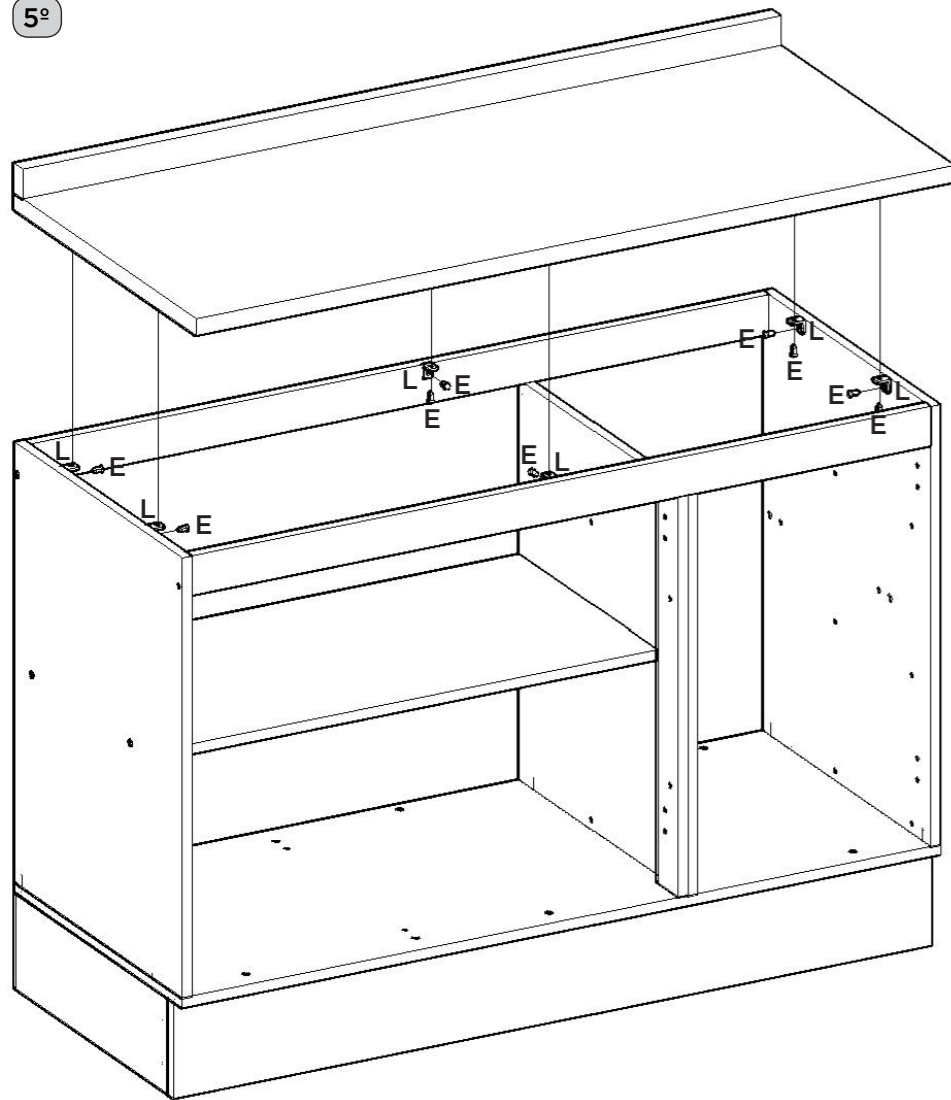

Caso o móvel seja montado com a opção do tampo, fixar o mesmo com 06 cantoneiras (L) e os parafusos 3,5x14mm (E).

Si se monta el auricular con la opción de la cubierta, fijarlo con Los ángulos 06 (L) y 3,5 x14mm tornillos (E).

If the furniture is to be installed with the top cover option, fix it with 06 (L) and 3.5x14mm screws (E).

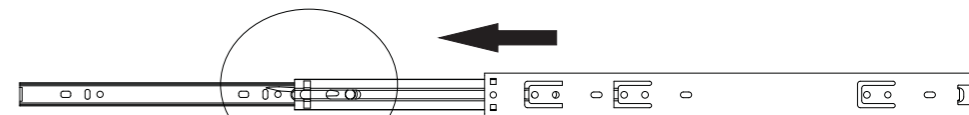
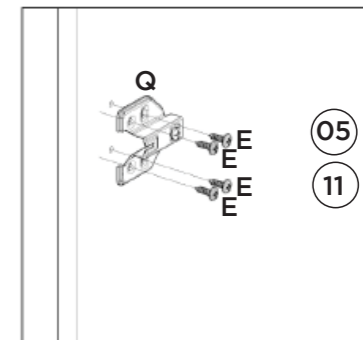
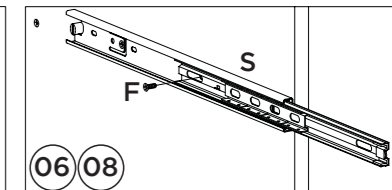
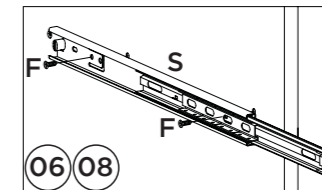
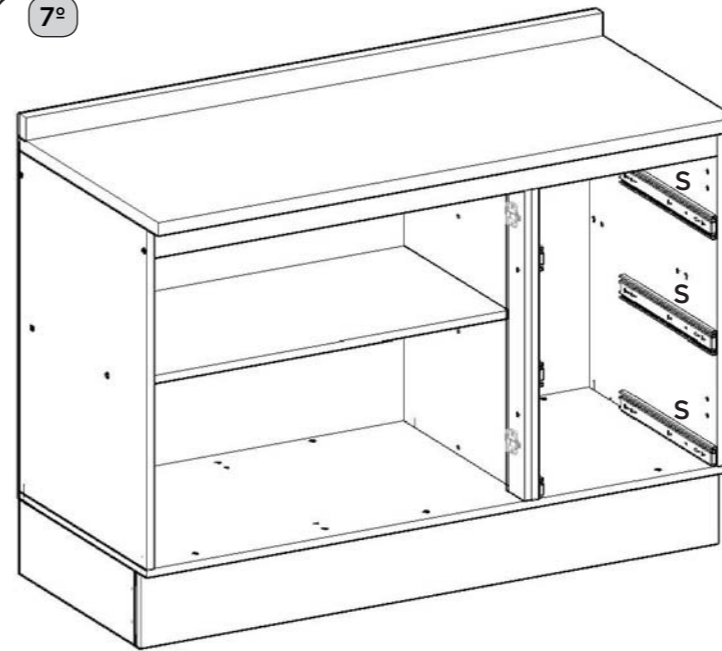

Para a desmontagem da corredeira siga a instrução ao lado.

Para el desmontaje seguimiento de diapositivas la instrucción siguiente a.

For the dismount of the sliding onem follows the instruction aside.

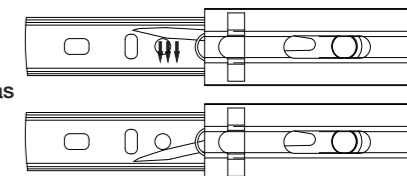

Fixar as corredeiras nessas furações
Fijar las diapositivas de estos agujeros
Fix slides in these drillings

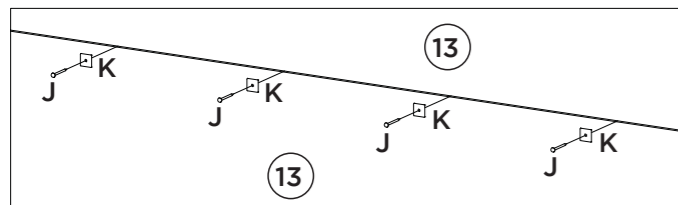
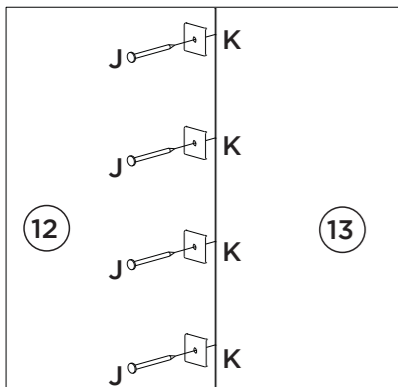
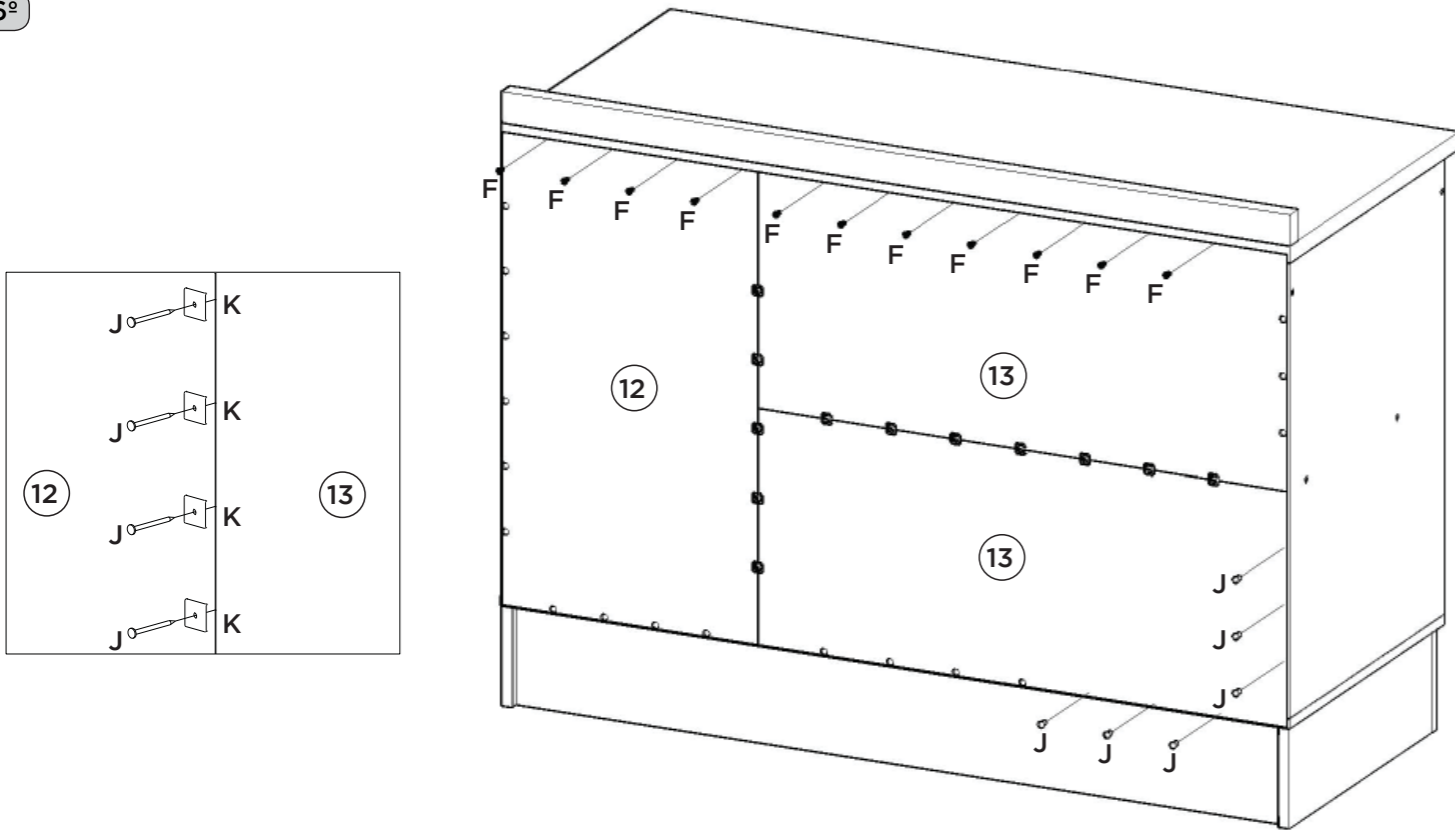

Opção Suspensa

Opción suspendida

Suspended Option

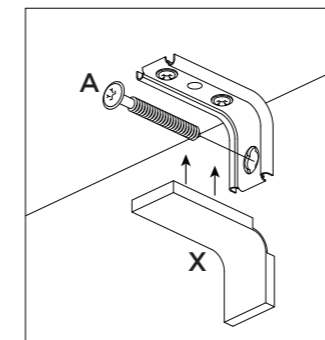
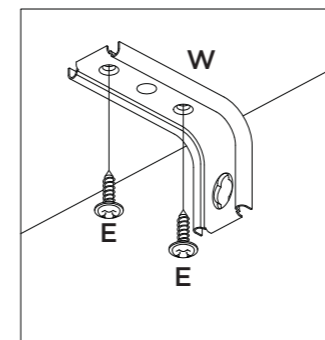

Parede
pared
Wall

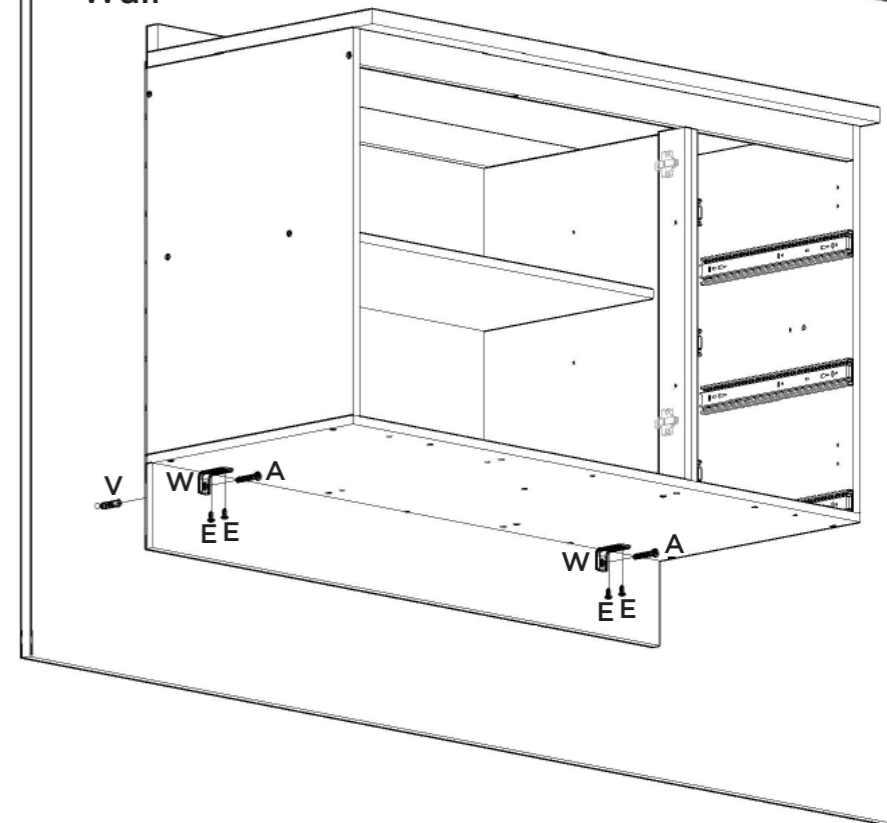

Agora que você já comprou o seu móvel, ele merece ser montado do jeito certo.

Erros de montagem causam mais de **60%** dos danos em móveis.

Por que contratar?

Tranquilidade do **início ao fim** da montagem



PROFISSIONAIS QUALIFICADOS

Especialistas certificados na **MadeiraMadeira Serviços**.



FERRAMENTAS PROFISSIONAIS

que **protegem** seus móveis.



AGENDAMENTO EM 24 HORAS

escolha a data e o turno **ideais para** você.



GARANTIA DE 3 MESES

de cobertura **completa**.

Mais de 1 MILHÃO DE MONTAGENS
★ com avaliação **4.7** ★

Mariana S., São Paulo

"Chegaram no horário e montaram tudo rapidamente. Serviço incrível!"



Carlos R., Belo Horizonte

"Tentei montar sozinho e foi um desastre. Com a **MadeiraMadeira Serviços** ficou perfeito."



Ana P., Rio de Janeiro

"Agendamento ágil e **montagem pontual e perfeita**. Recomendo demais!"



Agende agora pelo QR Code

Madeira**Madeira** Serviços · Atendimento em todo o Brasil



Escaneie o QRCode