

**HENN**Ind. e Com. de Móveis Henn  
Mondai - SC - Brasil

☎+55 49 3674.3500

📧@moveishenn  
www.henn.com.br**INSTRUÇÕES DE MONTAGEM**INSTRUCCIONES DE MONTAJE  
ASSEMBLY INSTRUCTIONS**Cômoda 06 Gavetas Pão de Mel |**

Dresser 06 Cajones Pão de Mel |

Chest of drawers 06 Drawers Honeycomb

I709-10 Branco

I709-18 Rústico/Branco

**Requisitos para montagem**

Requisitor para la montaje

Assembly Requirements

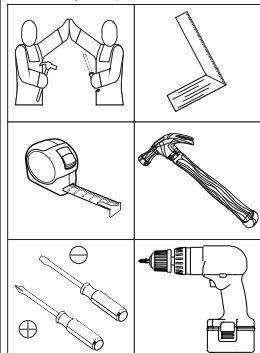
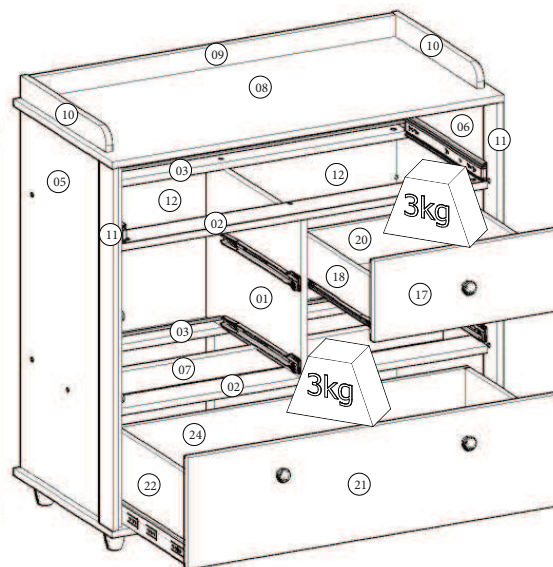
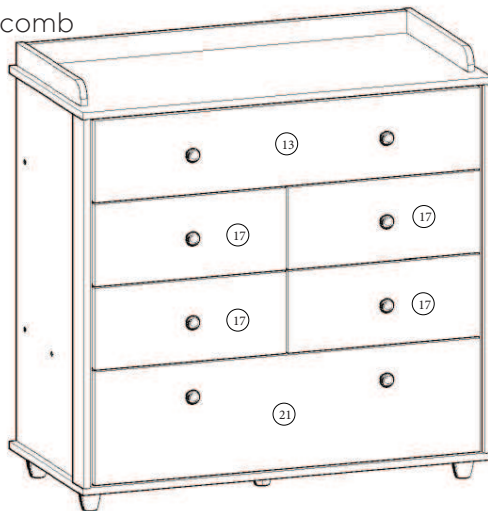
Imagens meramente ilustrativas  
Imágenes meramente ilustrativas  
Images for illustration only**Pesos máximos recomendados com carga distribuída**

Peso máximo recomendado con la carga distribuida

Recommended maximum weights with evenly distributed.

**Lista de Peças | Lista de piezas | List of parts**

Item	Caixa Box	Qty	Descrição   Descripción	Medidas (mm)   Dimensions (mm)   Size (measure- ments) (mm)	Código das Peças   Código de las piezas   Parts Code
01	1/1	01	Divisão   División   Division	352x410x15	03061499
02	1/1	02	Travessa frontal   Travesaño delantero   Front crossbar	867x73x15	03301414
03	1/1	02	Travessa traseira   Travesaño trasero   Rear bumper	867x73x15	03301415
04	1/1	01	Base   Base   Base	930x425x15	03293296
05	1/1	01	Lateral Esquerda   Lateral izquierda   Left Side	810x410x15	03153378
06	1/1	01	Lateral Direita   Lateral derecha   Right side	810x410x15	03153377
07	1/1	01	Travessa Estrutural MDF   Travesaño estructural MDF   MDF Structural Truss	867x50x25	03301413
08	1/1	01	Tampo   Tapa   Top	930x425x15	03293297
09	1/1	01	Moldura Superior   Cornija superior   Upper Frame	867x48x15	03161395
10	1/1	02	Moldura Lateral Superior MDF   Cornija lateral superior MDF   MDF Top Side Frame	390x50x15	03161393
11	1/1	02	Moldura Lateral   Cornija lateral   Lateral Frame	810x60x15	03161394
12	1/1	02	Fundo Cru   Fondo prima   Raw Fund	837x445x3	03111660
13	1/1	01	Frente de Gaveta Superior   Frente del Cajón Superior   Upper Drawer Front	877x180x15	03131282
14=18	1/1	02	Lado de gaveta   Lado del cajón   Side of drawer	350x110x12	03140619
15=23	1/1	01	Fundo de Gaveta Maior   Fondo mayor del cajón	829x361x3	03240728
16	1/1	01	Ripa de trás   Malla detrás   Rear lath	842x110x12	03240727
17	1/1	04	Frente de gaveta   Frente de cajón   Front of drawer	436x180x15	03131280
18=14	1/1	08	Lado de gaveta   Lado del cajón   Side of drawer	350x110x12	03140619
19	1/1	04	Fundo de gaveta   Fondo del cajón   Drawer bottom	388x361x3	03120550
20	1/1	04	Ripa de Trás Menor   Malla detrás menor   Rear lath Minor	401x110x12	03240729
21	1/1	01	Frente de Gaveta Larga   Frente larga del cajón   Front of Large Drawer	877x250x15	03131281
22	1/1	02	Lado de Gaveta Maior   Lado mayor del cajón   Larger Drawer Side	350x180x12	03140620
23=15	1/1	01	Fundo de Gaveta Maior   Fondo mayor del cajón   Large Drawer Background	829x361x3	03120551
24	1/1	01	Ripa de Trás Maior   Listón trasero mayor   Rear lath Bigger	842x180x12	03240728

**AVISO**

Para limpeza de seu móvel, use uma flanela seca ou umedecida, e não utilize produtos químicos que possam danificar seu produto.

**SISTEMA DE MONTAGEM**

O sistema de montagem dos produtos, funciona de acordo com a ordem crescente dos números indicados no desenho. Ex: 01, 02, 03, 04... até a conclusão da montagem.

**ADVERTENCIA**

Para limpieza de su móvil, use una flanela seca o húmeda, y no utilice productos químicos que puedan dañar su producto.

**SISTEMA DE MONTAJE**

El sistema de montaje de los productos funciona de acuerdo con el orden creciente de los números indicados en el dibujo. Ej: 01, 02, 03, 04... hasta la conclusión del montaje.

**NOTICE**

To clean your furniture, use a dry or wet cloth, and do not use chemicals that may damage your product.

**ASSEMBLY SYSTEM**

The products' assembly system works according to the increasing order of the indicated numbers. For example: 01, 02, 03, 04 ... to the end of the assembly.

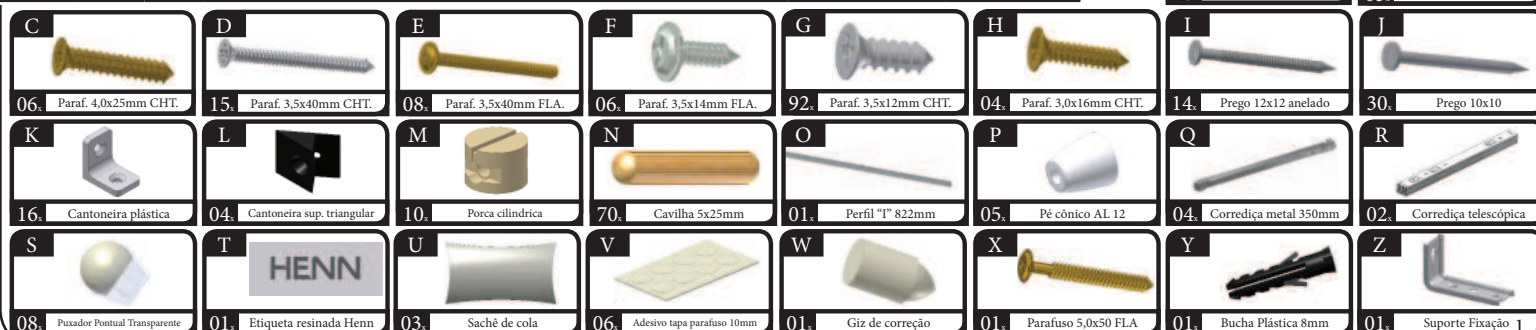
**Lista de Ferragens / Lista de Herrajes**

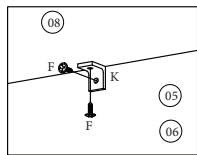
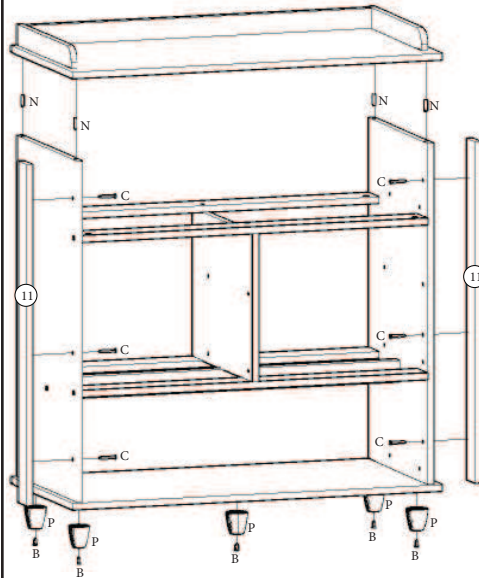
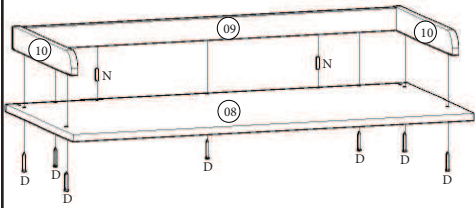
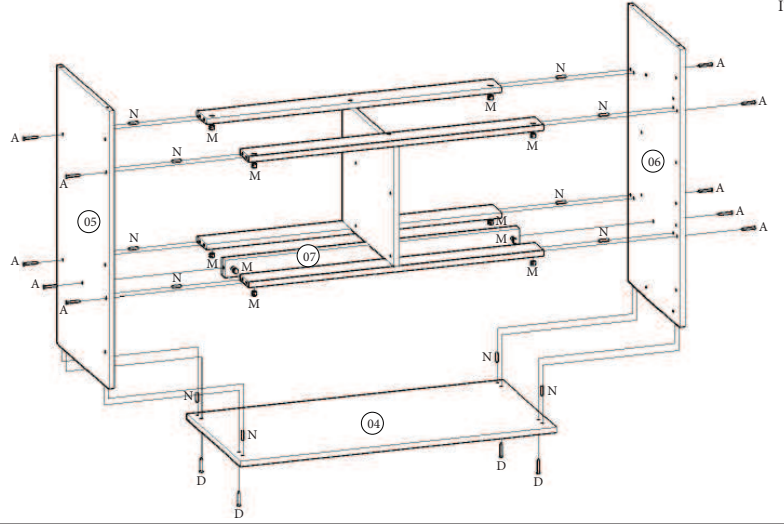
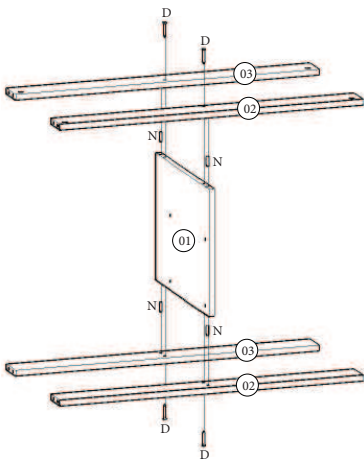

2 Cantoneiras próximo das bordas da frente das Laterais (05 e 06)

2 cenefas cerca de los bordes frontales de los lados (05 y 06)

2 Corners near the front edges of the Sides (05 and 06)

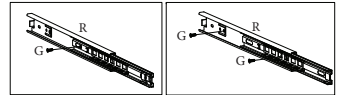
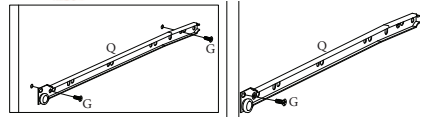
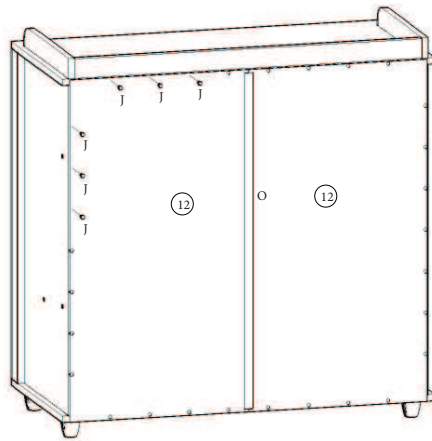

Imprescindível a fixação do produto na parede, a não colocação destas ferragens para fixação (F, X, Y e Z), poderá permitir que o produto vire, causando acidente.

Es imprescindible la fijación del producto en la pared, la no colocación de estos herrajes para fijación (F, X, Y e Z), podrá permitir que el producto se vuelva, causando accidente.

Indispensable to fix the product on the wall, not the placement of these attachment fittings (F, X, Y and Z) may allow the product to turn, causing an accident.

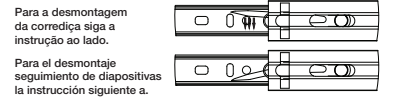
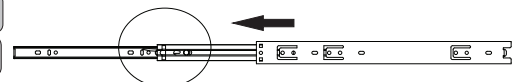
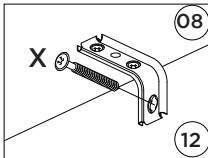
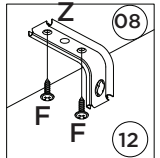

Para a desmontagem da correção siga a instrução ao lado.

Para el desmontaje seguimiento de dispositivos la instrucción siguiente a.

Fixar as correções nessas furações  
Fijar las dispositivos de estos agujeros

Gaveta superior    Cajón superior    Upper drawer

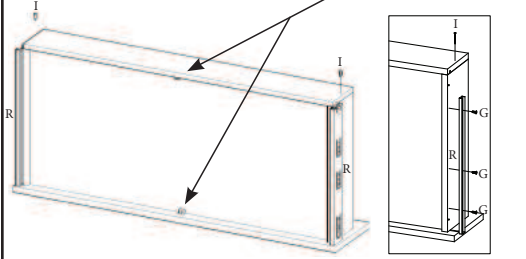
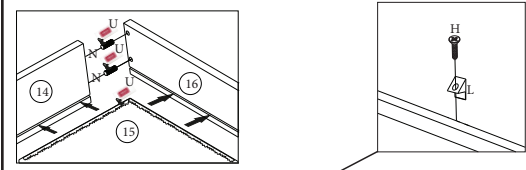
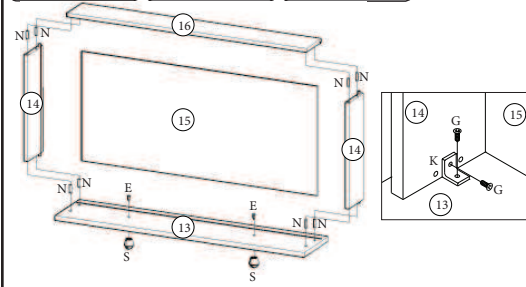

Gaveta 4x    Cajón 4x    4x Drawer

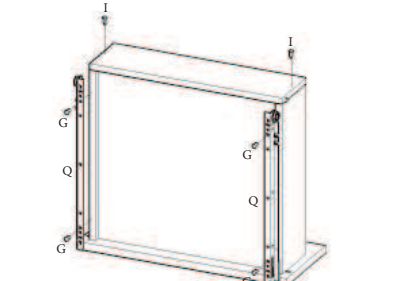
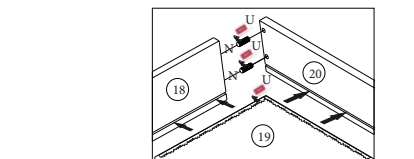
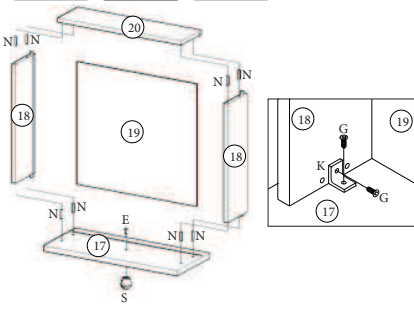

Gaveta larga    Cajón larga    Large drawer

