

INSTRUÇÃO DE MONTAGEM INSTRUCCIONES DE MONTAJE ASSEMBLY INSTRUCTIONS

HENN

Cômoda Flor de Lis 05 Gavetas / Dresser 5 cajones Flor de Lis / Flor de Lis Dresser with 05 Drawers

Referência/Cor

- D703-05 - Branco HP
- D703-10 - Branco
- D703-25 - Nogueira
- D703-39 - Turin
- D703-42 - Fendi
- D703-70 - Amêndoa
- D703-83 - Moka
- D703-94 - Rústico
- D703-101 - Café

Requisitos para montagem

Requisitor para la montaje
Assembly Requirements

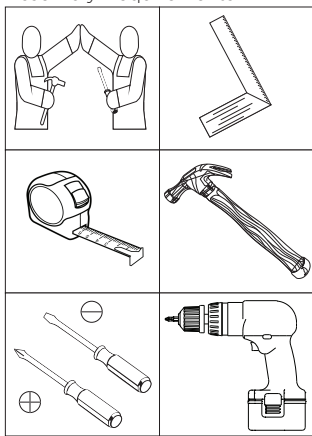

Imagens meramente ilustrativas
Imágenes meramente ilustrativas
Images for illustration only

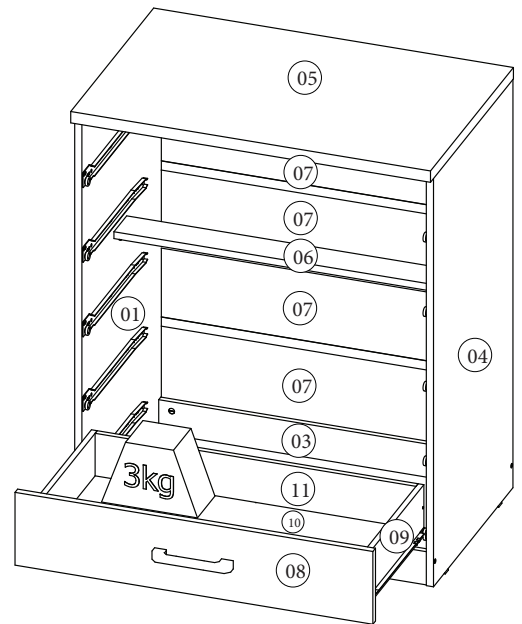
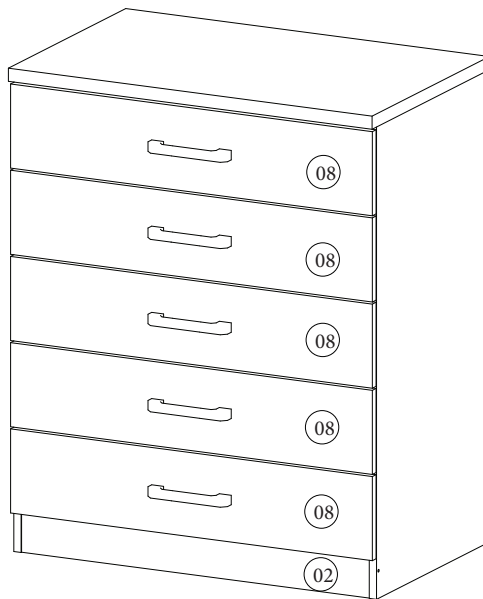

Pesos máximos recomendados com carga distribuída
Peso máximo recomendado con la carga distribuida
Recommended maximum weights with evenly distributed.

AVISO

Para limpeza de seu móvel, use uma flanela seca ou umedecida, e não utilize produtos químicos que possam danificar seu produto.

SISTEMA DE MONTAGEM

O sistema de montagem dos produtos, funciona de acordo com a ordem crescente dos números indicados no desenho. Ex: 01, 02, 03, 04... até a conclusão da montagem.

ADVERTENCIA

Para limpieza de su móvil, use una flanela seca o húmeda, y no utilice productos químicos que puedan dañar su producto.

SISTEMA DE MONTAJE

El sistema de montaje de los productos funciona de acuerdo con el orden creciente de los números indicados en el dibujo. Ej.: 01, 02, 03, 04... hasta la conclusión del montaje.

NOTICE

To clean your furniture, use a dry or wet cloth, and do not use chemicals that may damage your product.

ASSEMBLY SYSTEM

The products' assembly system works according to the increasing order of the indicated numbers. For example: 01, 02, 03, 04 ... to the end of the assembly.

Lista de Peças | Lista de piezas | List of parts

Item	Caixa Box	Qty Qty	Descrição / Descripción	Medidas (mm) Dimensions (mm) Size (measurements) (mm)
01	1/1	01	Lateral esquerda/ Lado Izquierdo / Left side	899x455x15
02	1/1	01	Rodapé frontal/ Pie frontal / Front baseboard	718x73x12
03	1/1	01	Rodapé traseiro/ Pie trasero / Rear baseboard	718x73x12
04	1/1	01	Lateral direita/ Lateral derecho / Right side	899x455x15
05	1/1	01	Tampo superior/ Cubierta mayor / Top cover	750x475x25
06	1/1	01	Travessa estrutural/ Travesaño estructural / Structural crosspiece	718x73x15
07	1/1	05	Fundo cru/ Fondo crudo / Raw bottom	737x165x3
08	1/1	05	Frete de gaveta/ Frete de cajón / Front of drawer	746x160x15
09	1/1	10	Lado de gaveta/ Lado del cajón / Side of drawer	350x110x12
10	1/1	05	Fundo de gaveta/ Fondo del cajón / Bottom of drawer	680x349x3
11	1/1	05	Ripa de trás/ Malla detrás / Rear lath	669x110x12

Ferragens | Herrajes | Hardware

A Parafuso 4,5x50mm CHT. Tornillo 4,5x50mm CHT. Screw 4,5x50mm CHT.	B Parafuso 3,5x25mm FLA. Tornillo 3,5x25mm FLA. Screw 3,5x25mm FLA.	C Parafuso 3,5x14mm FLA. Tornillo 3,5x14mm FLA. Screw 3,5x14mm FLA.	D Parafuso 3,5x12mm CHT. Tornillo 3,5x12mm CHT. Screw 3,5x12mm CHT.	E Parafuso 3,0x16mm FLA. Tornillo 3,0x16mm FLA. Screw 3,0x16mm FLA.	F Cantoneira plástica Cantoneira plástica Plastic angle brackets	G Cavilha 5x25mm Cinta 5x25mm Dowel 5x25mm	H Sapata "L" 15x15mm Zapata "L" 15x15mm "L" shoe 15x15mm
I Prego 12x12mm Anilado Clavo 12x12mm Anilado Ringed Nails 12x12mm	J Prego 10x10mm Clavo 10x10mm Nail 10x10mm	K Porca cilíndrica Tuerca cilíndrica Cylindrical nut	L Puxador Iris 128mm Tirador Iris 128mm Iris Handle 128mm	M Cantoneira suporte triangular Cantoneira soporte triangular Triangle support angle	N Corrediza metal 350mm Corredera de metal 350mm Sliding metal 350mm	O Perfil "H" 728mm Perfil "H" 728mm Profile "H" 728mm	P Sachê de cola Bolsa de pegamento Glue bag
Q Adesivo tapa parafuso 10mm Adhesivo tapón de tornillo 10mm Bolt cover adhesive 10mm							

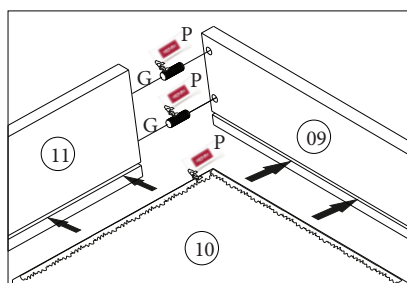
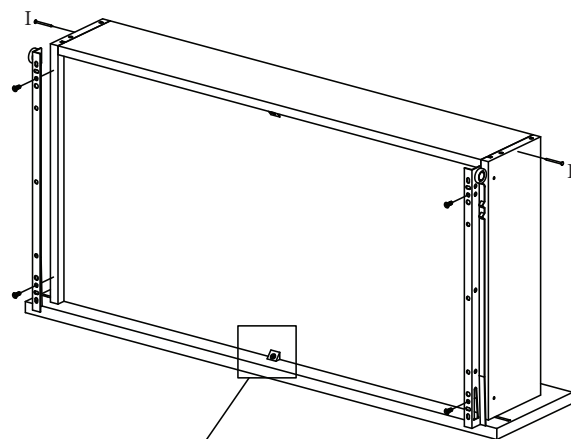
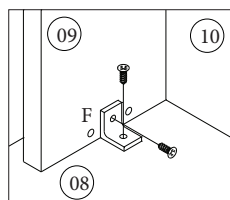
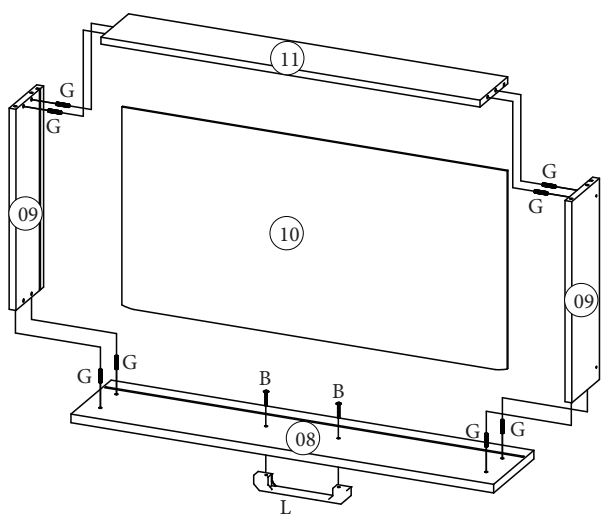
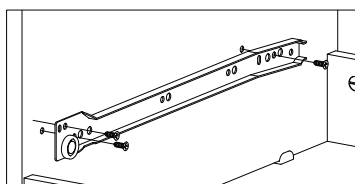
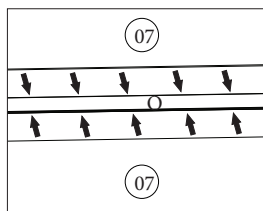
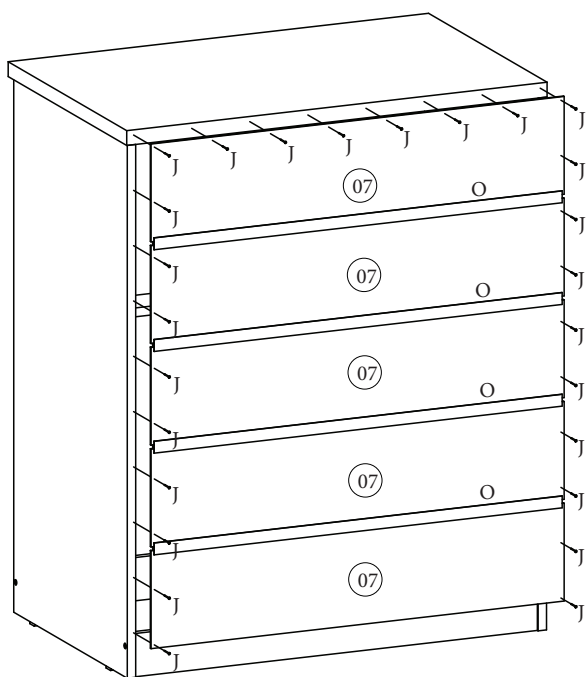
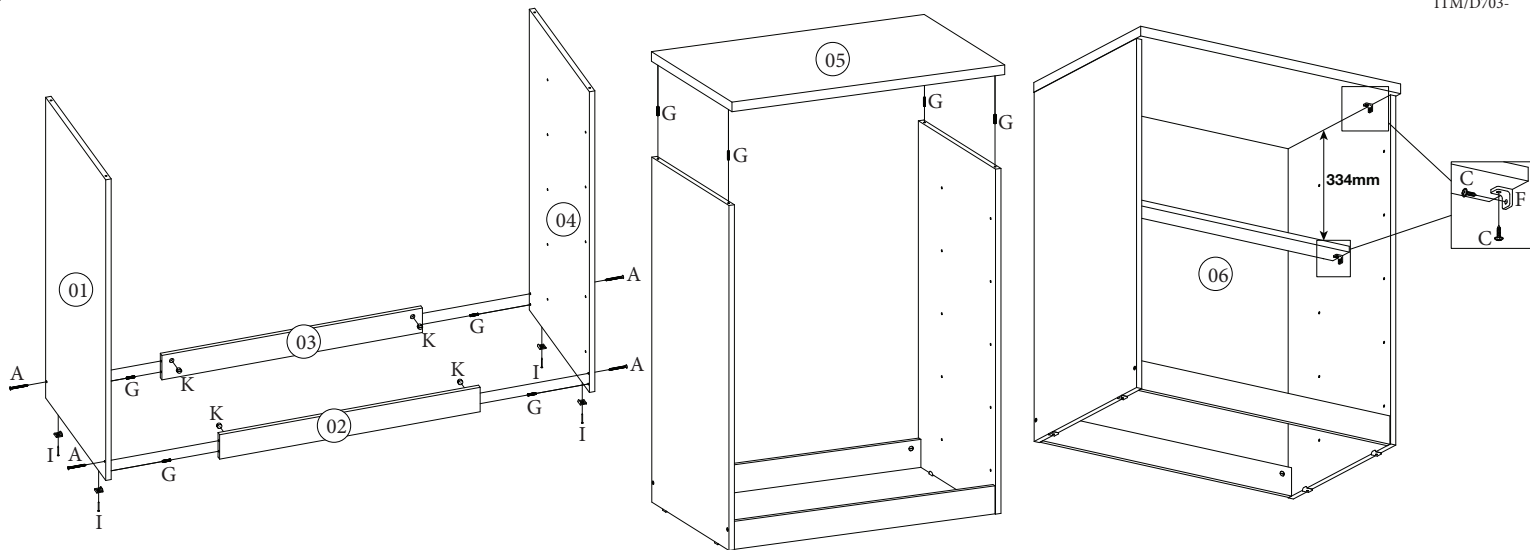

Utilize o sachê de cola (P) nas cavilhas (G) e nos frisos das gavetas.

Utilice pegamento sobre (P) en los pernos (G) y los cajones de los granos.

Use the glue sachet (P) in the pins (G) and in the ledges of the drawers.

