

ASSEMBLY INSTRUCTIONS

MANUAL DE MONTAGEM / INSTRUCCIONES DE ARMADO

Delta Trestle table
Mesa cavalete Delta
Mesa caballete Delta

Reference
Referência
Referencia

160747

Revise
Revisão
Revisión

03

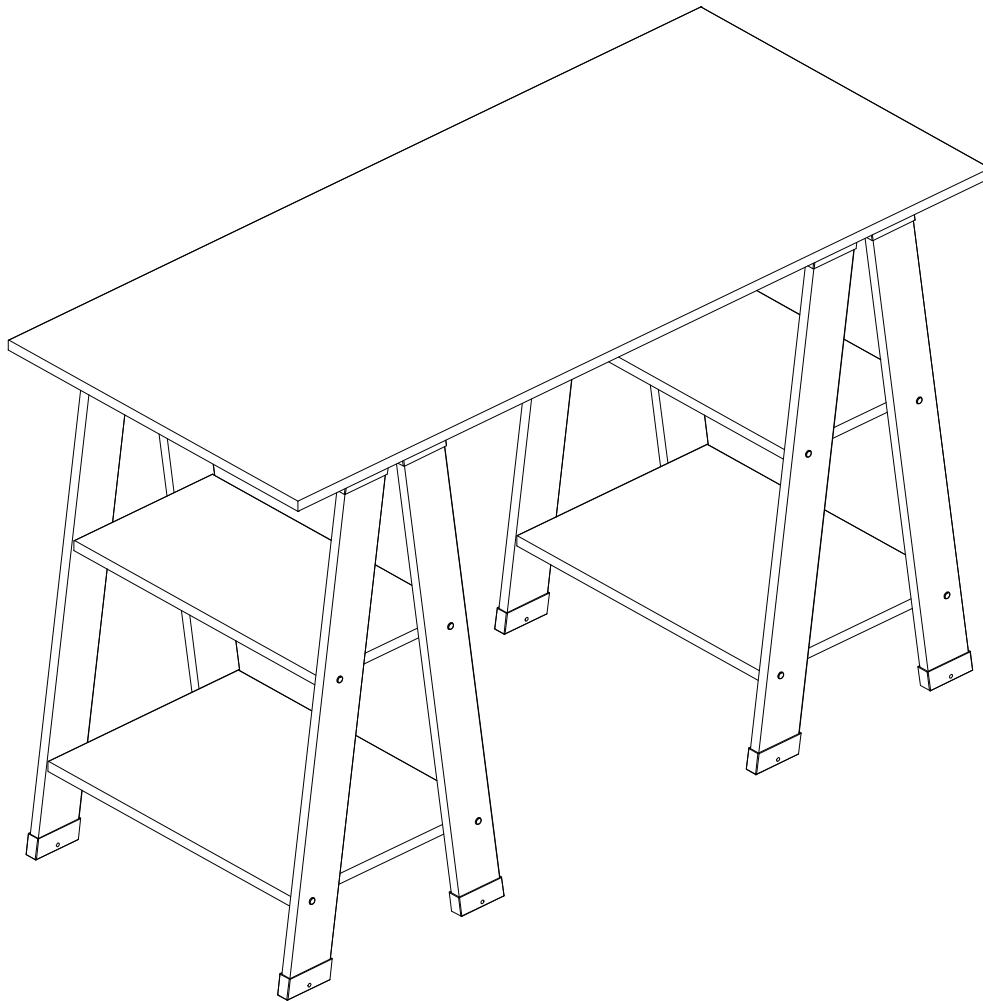

YOU WILL NEED / VOCÊ VAI PRECISAR DE / USTED NECESITARÁ

Tools not supplied / Ferramentas não fornecidas / Herramientas no incluidas

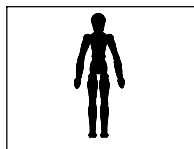

1 Person
1 Pessoa
1 Persona

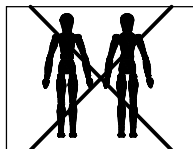

2 People
2 Pessoas
2 Personas

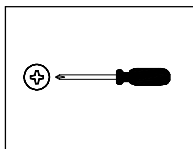

Screwdriver Phillips
Chave Phillips
Destornillador cruz

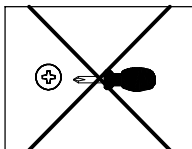

Small screwdriver Phillips
Chave Phillips Menor
Destornillador cruz menor

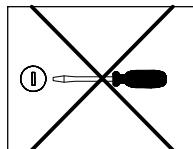

Screwdriver slotted
Chave fenda
Destornillador plano

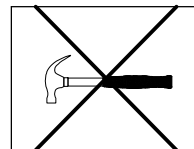

Hammer
Martelo
Martillo

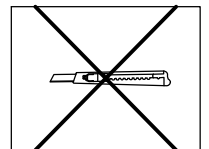

Stylet
Estilete
Estilete

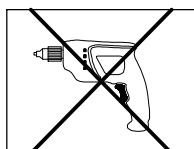

Drill machine
Furadeira
Taladro

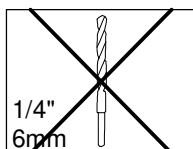

Drill bit
Broca
Taladro

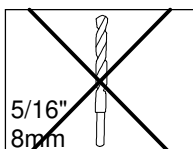

Drill bit
Broca
Taladro



Measuring tape
Trena
Cinta de medición

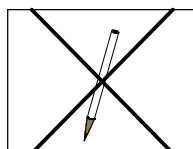

Pencil
Lápis
Lápis

NOTES: The separation of the accessories before you start the assembly will facilitate the same. In case of doubt on the size of the screws and bolts, use the ruler to bottom of page 3.

NOTAS: A separação dos acessórios antes de iniciar a montagem facilitará a mesma. Em caso de dúvida no tamanho dos parafusos e cavilhas, utilize a régua ao final da página 3.

NOTAS: La separación de los accesorios antes de comenzar el armado facilitará el mismo. En caso de duda sobre el tamaño de los tornillos y taquetes, utilice la regla al pie de página 3.

MAXIMUM RECOMMENDED WEIGHT
BEING THIS EVENLY DISTRIBUTED

PESO MÁXIMO RECOMENDADO SENDO
ESTE DISTRIBUÍDO UNIFORMEMENTE

PESO MÁXIMO RECOMENDADO SIENDO
ESTE UNIFORMEMENTE DISTRIBUIDO

	LB	KG
A	44	20
B	11	5

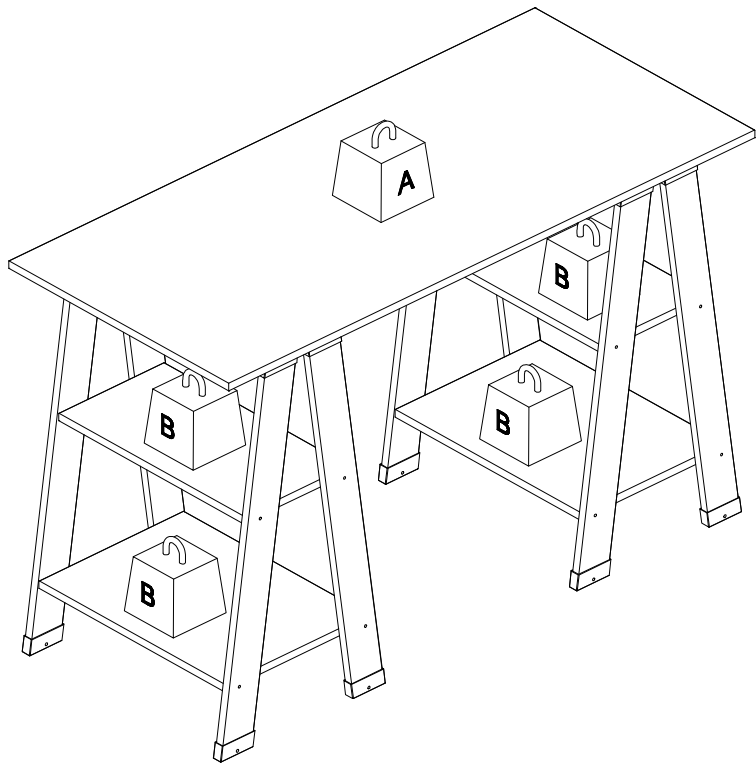

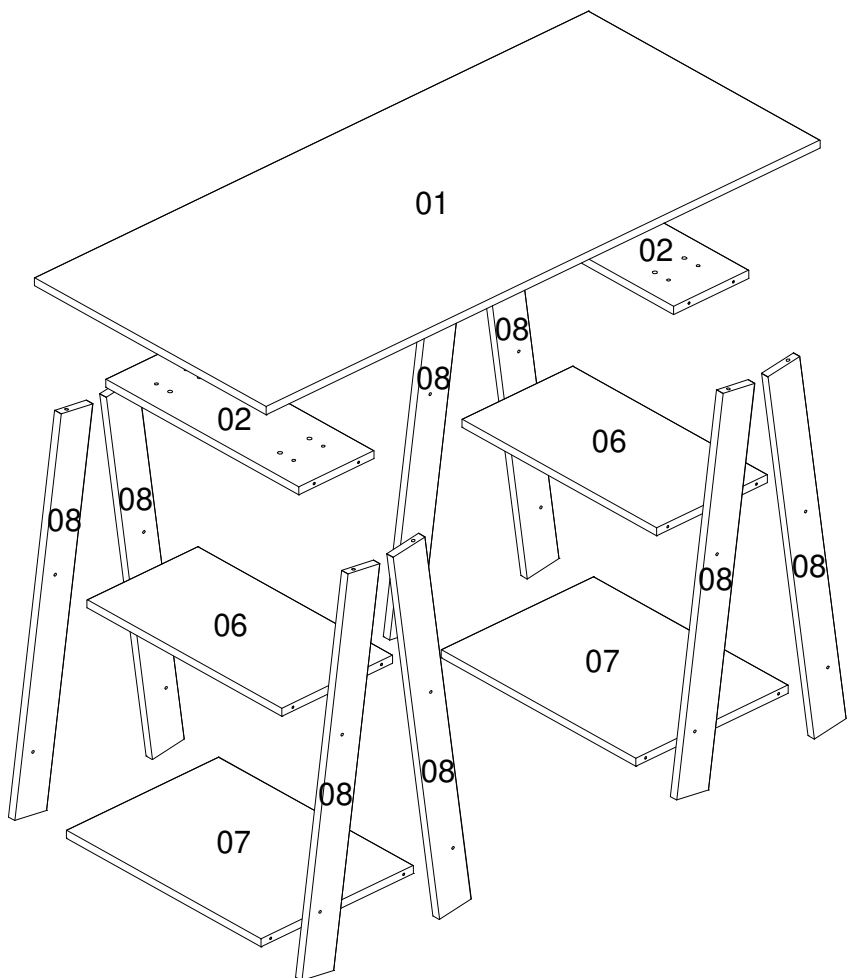

Nº	Measures Inches	Medidas cm	Qty./Qtd.
01	47 1/4 x 21 1/4 x 5/8	120 x 54 x 1,5	1
02	17 3/4 x 6 1/4 x 5/8	45 x 16 x 1,5	2
06	17 7/8 x 9 1/2 x 5/8	45,4 x 24 x 1,5	2
07	17 7/8 x 13 x 5/8	45,4 x 33 x 1,5	2
08	28 3/8 x 2 3/4 x 5/8	72 x 7 x 1,5	8

PARTS IDENTIFICATION
IDENTIFICAÇÃO DAS PEÇAS / IDENTIFICACIÓN DE LAS PIEZAS

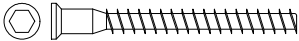

IDENTIFICATION OF ACCESSORIES IDENTIFICAÇÃO DOS ACESSÓRIOS/ IDENTIFICACIÓN DE ACCESORIOS

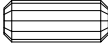
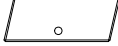
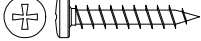
G		Structural screw / Parafuso estrutural / Tornillo estructural	5,0x50 mm	24
H		Allen key / Chave allen / Liave allen	3 mm	2
I		Structural screw cover/Tampa parafuso estrutural/Tapa tornillo estructural	-	24
N7		Wooden dowel / Cavilha / Taquete	8x20 mm	8
Q17		Inclined foot / Ponteira inclinada / Pie inclinado	-	16
R19		Pan head screw / Parafuso panela / Tornillo de pan	4,0x25 mm	40



PRE-ASSEMBLE
PRÉ-MONTAGEM / PRE ARMADO

01



ATTENTION for pin position
ATENÇÃO para posição do pino
ATENCIÓN para la posición del pasador

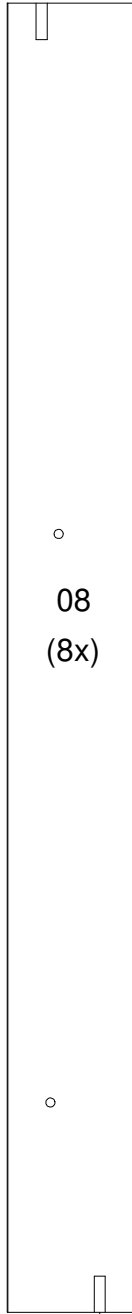
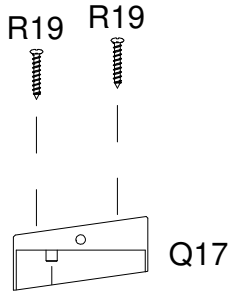
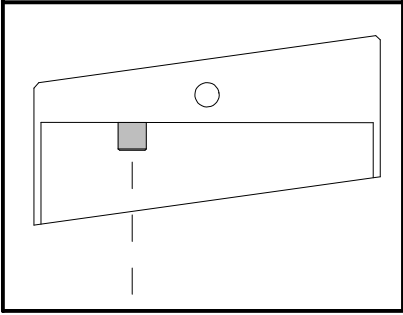

ATTENTION for pin position
ATENÇÃO para posição do pino
ATENCIÓN para la posición del pasador

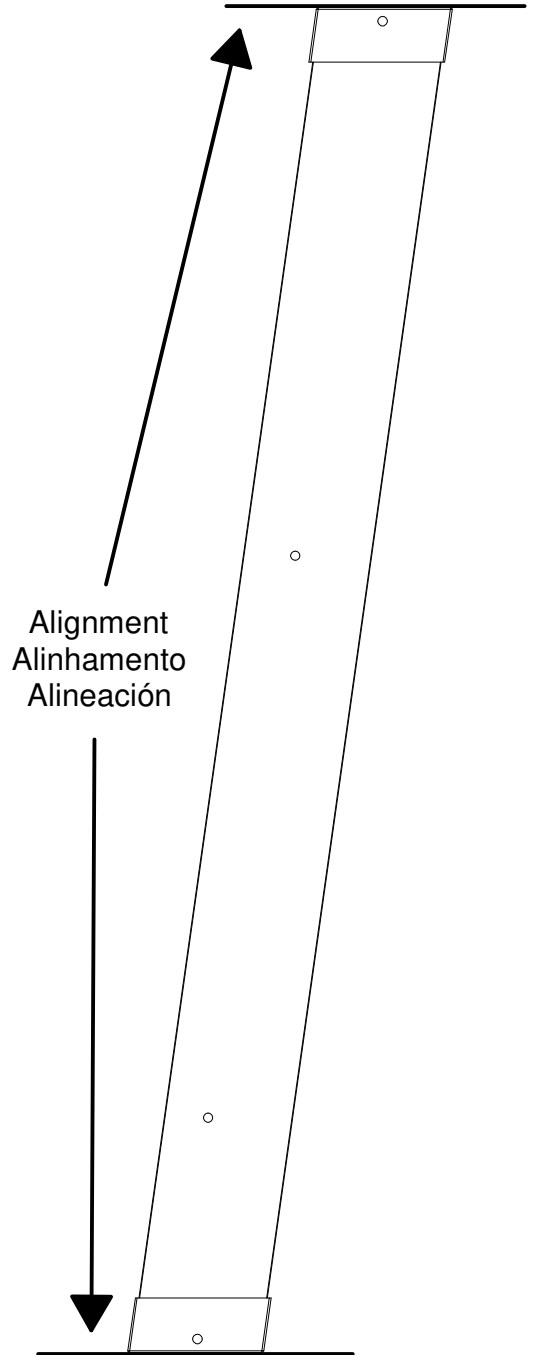
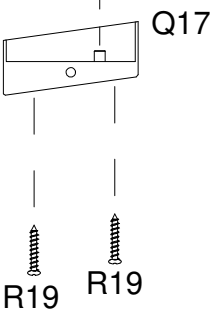
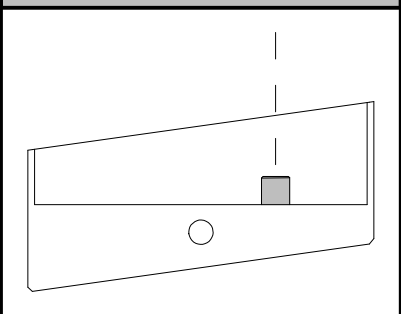

ASSEMBLY
MONTAGEM / ARMADO

02

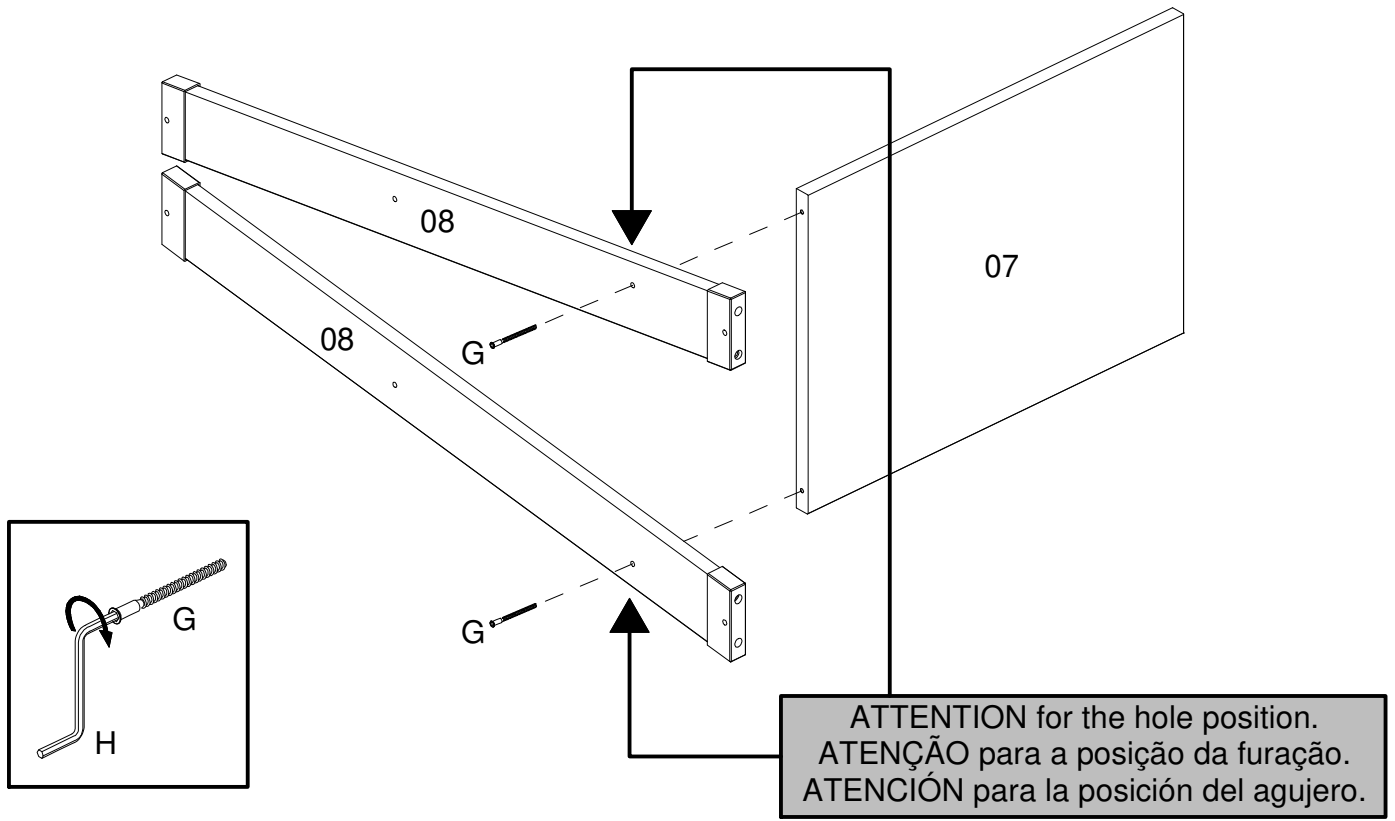

03

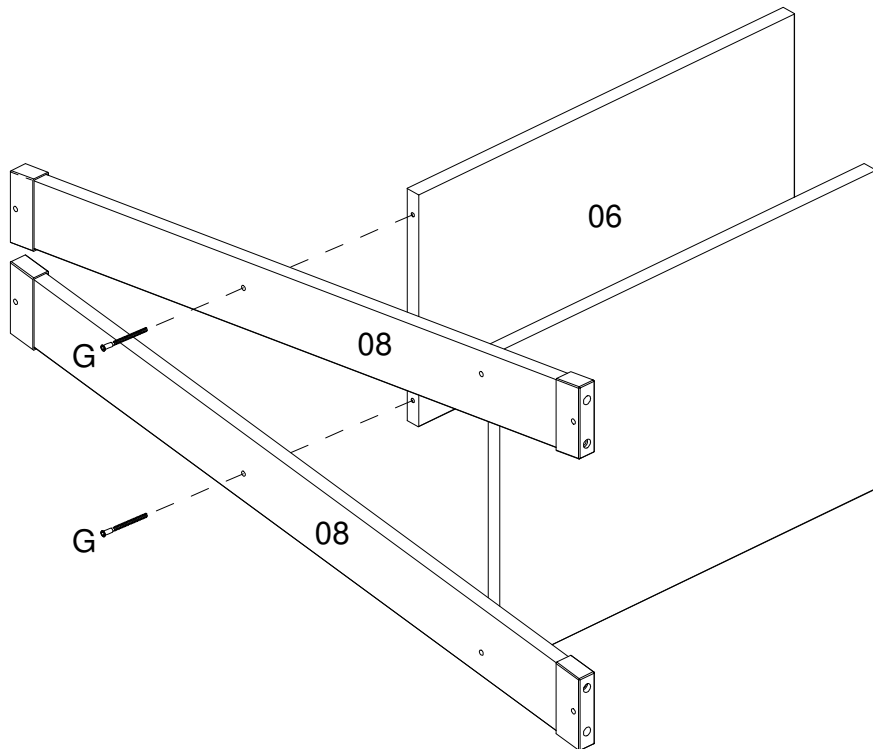

04

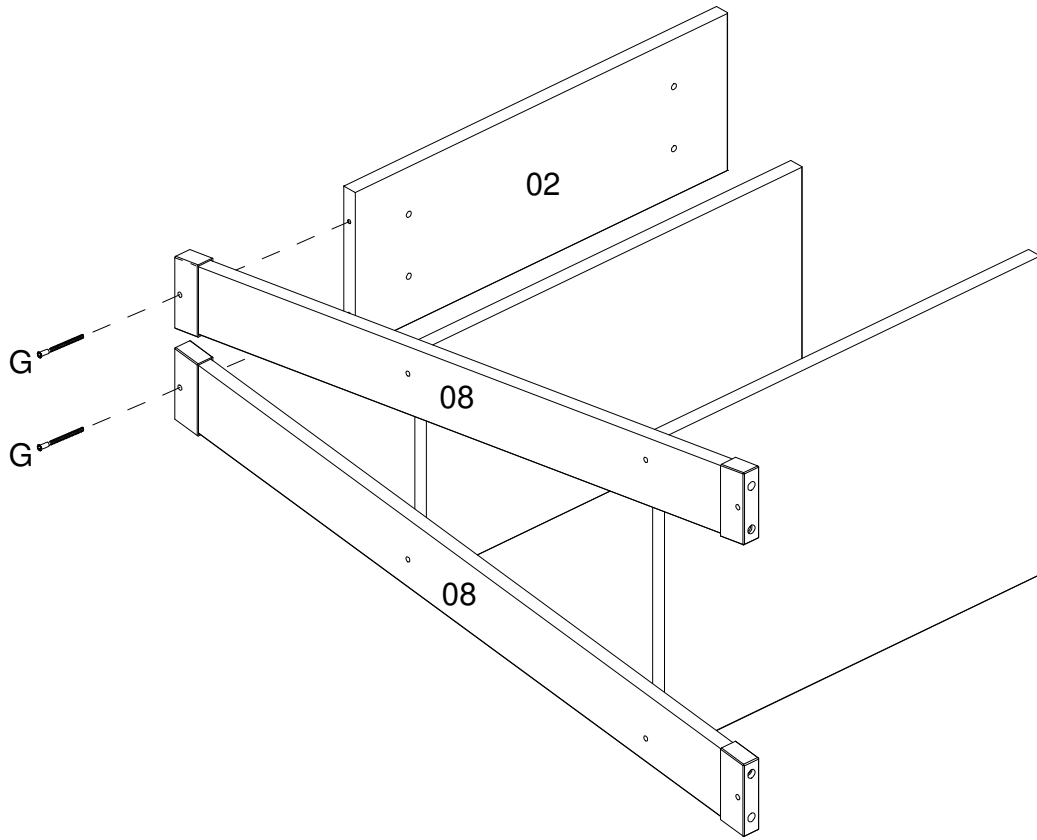

05

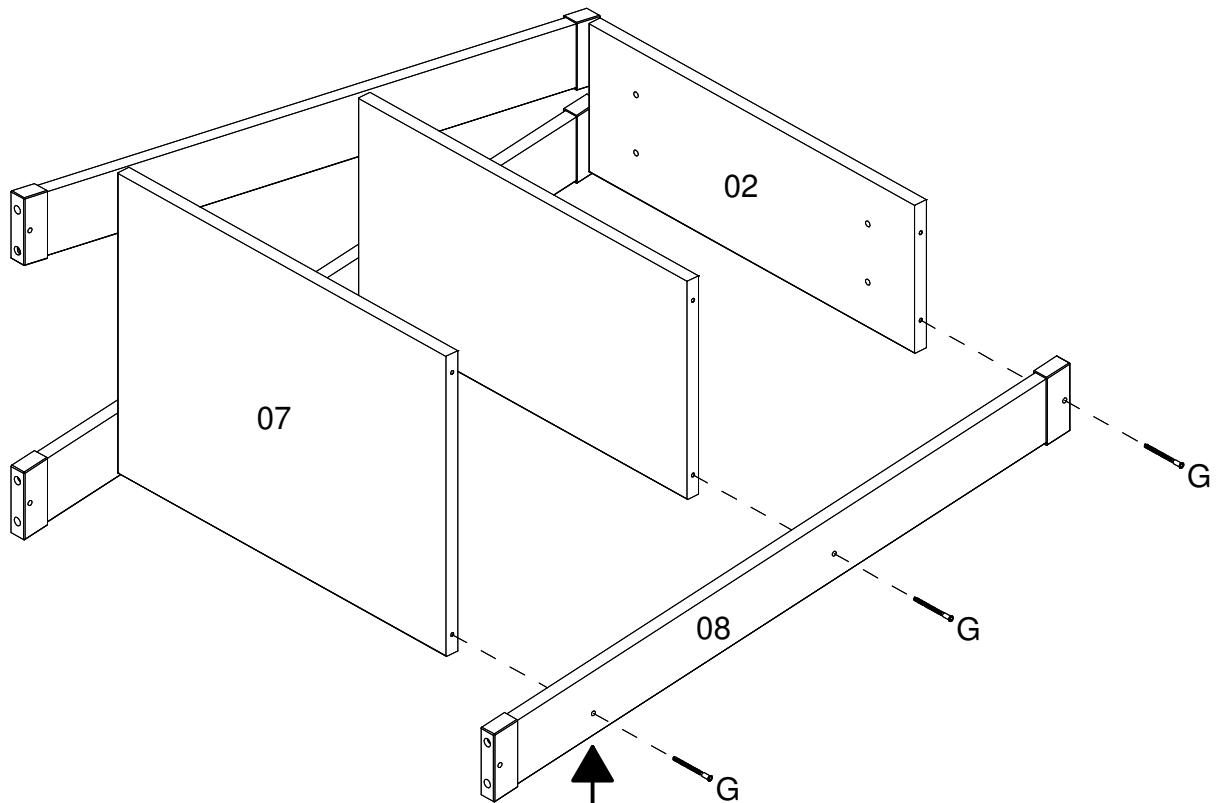

ATTENTION for the hole position.
ATENÇÃO para a posição da furação.
ATENCIÓN para la posición del agujero.

06

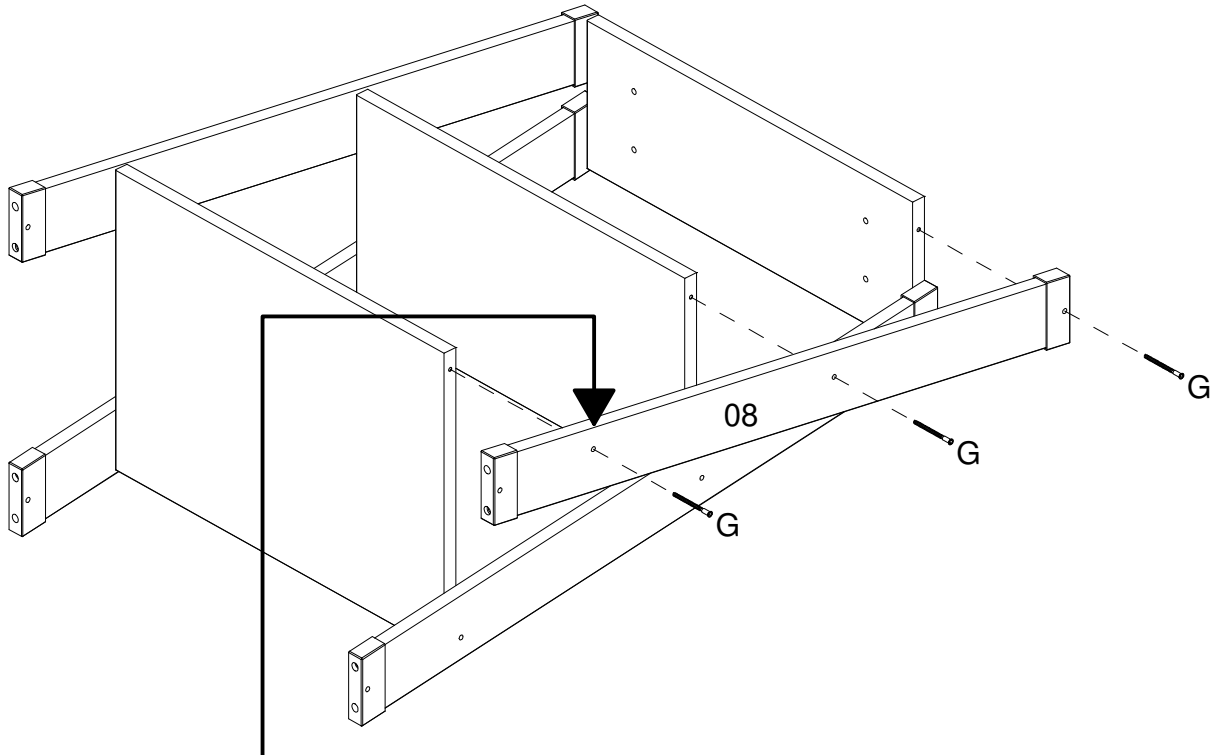

ATTENTION for the hole position.
ATENÇÃO para a posição da furação.
ATENCIÓN para la posición del agujero.

07

Feet assembly finished
Montagem dos pés finalizada
Armado de los pies finalizado

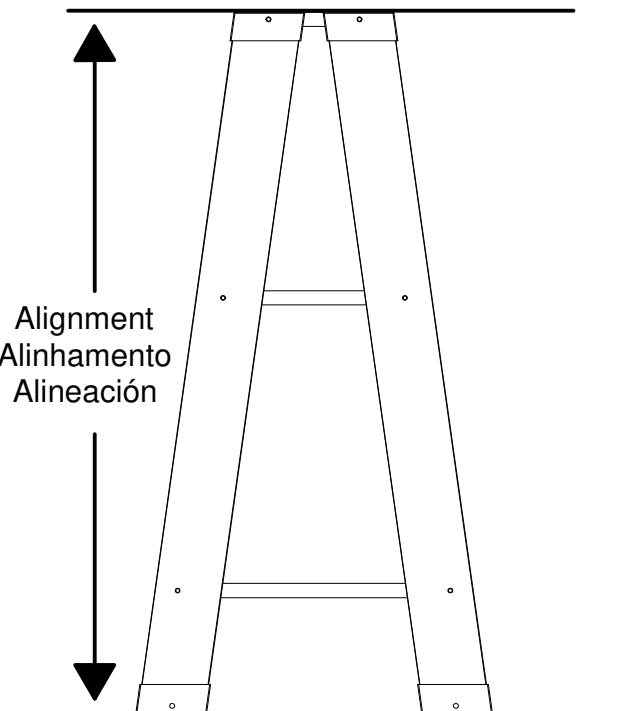
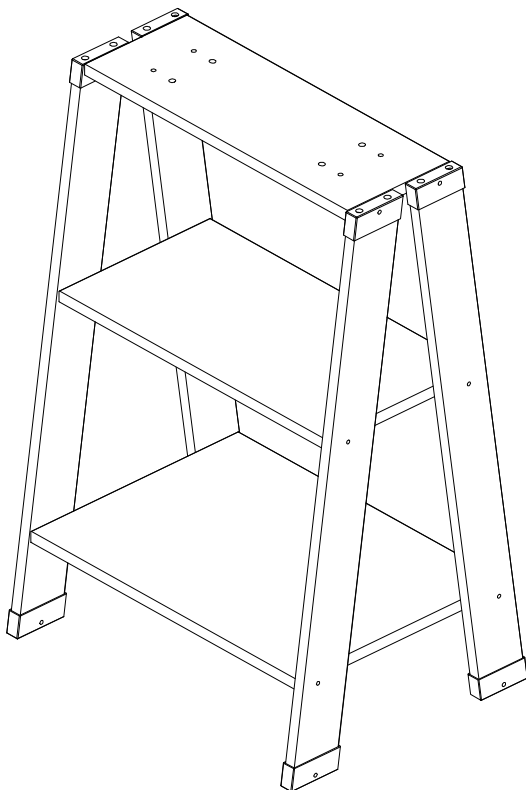

08

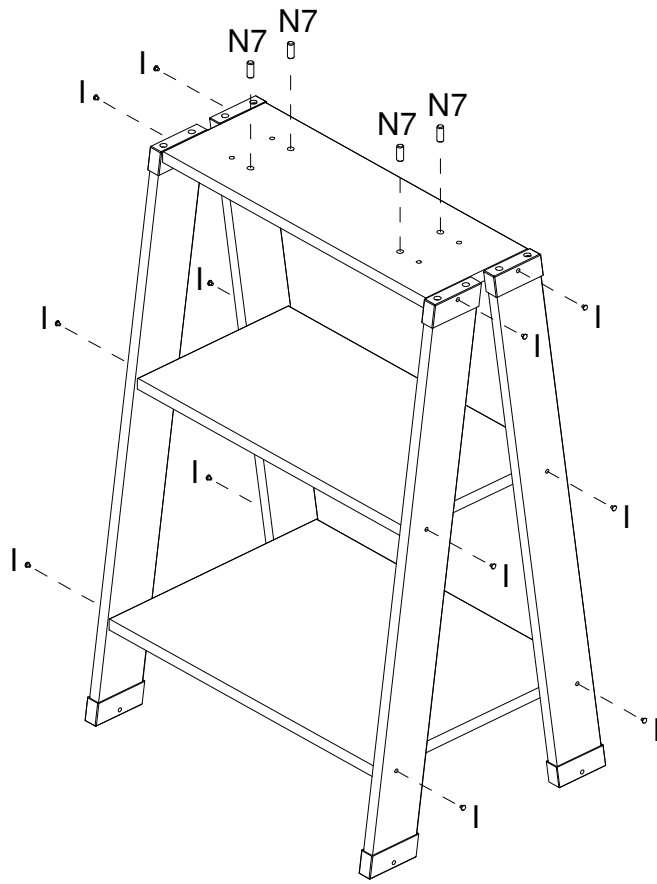

09

