

Passo / Step / Paso 5:

Prepare os fundos **utilizando** colocando os perfis H 649 entre eles.

Fixe os fundos **utilizando** pregos 8x8.

Fixe as Sapatas Laterais **utilizando** as laterais **utilizando** utilizando pregos 8x8.

Prepare Nº 12 and 13 with 'P'.

Fix 12 and 13 with 'D'.

Fix 'M' in Nº 01 and 02, with 'D'.

Prepare Nº 12 y 13 con 'P'.

Fix 12 y 13 con 'D'.

Fix 'M' en Nº 01 y 02,

con 'D'.

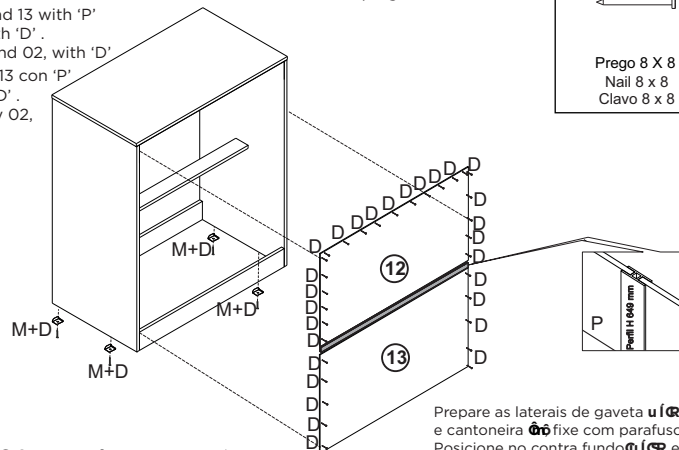

D	34 und.	M	04 und.
<p>Prego 8 X 8 Nail 8 x 8 Clavo 8 x 8</p>		<p>Sapata Lateral Side shoes Zapata lateral</p>	
P	01 und.		
<p>Perfil H 649 mm H Perfil 649 mm Perfil H 649 mm</p>			

Prepare as laterais de gaveta **utilizando** cavilha '10' e cantoneira **utilizando** e fixe com parafusos 3,0 x 10'.

Posicione no contra fundo **utilizando** e uma com os parafusos.

Una as laterais **utilizando** com a Frente de Gaveta utilizando parafusos 3,0 x 10 CC Phillips.

Fixe os puxadores **utilizando** uma peça **utilizando** com parafusos 4,0 x 25 CC Phillips.

Fixe os puxadores **utilizando** uma peça **utilizando** com parafusos 4,0 x 25 CC Phillips.

Passo / Step / Paso 6:

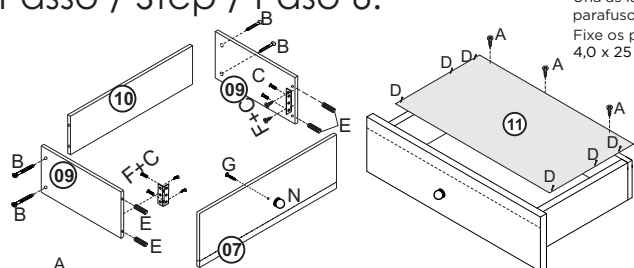

Prepare Nº 09 with 'E' y fije con 'F' y 'C'.

Fije 09 en Nº 10 con 'B'.

Fije Nº 09 en la pieza 07 con 'C'.

encajar Nº 11 en el canal Nº 07.

Fije 'N' en Nº 07 con 'G'.

Prepare Nº 09 with 'E' and fix with 'F' and 'C'.

Fix 09 in Nº 10 with 'B'.

Fix Nº 09 in the 07 with 'C'.

Fix 'N' in Nº 07 with 'G'.

Vire a gaveta com o fundo para cima e fixe utilizando Pregos 8x8 e parafusos 3,0 x 20 CC Phillips, em seguida fixe as corrediças **utilizando** do lado esquerdo e do lado direito nas peças **utilizando** utilizando parafusos 3,0 x 10 CC Phillips e parafusos 3,0 x 20 CC Phillips. **utilizando** fixe a cantoneira triangular 14 x 14 mm **utilizando** com parafuso 4,0 x 16 cc Phillips.

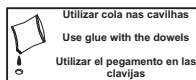

Fix 11 with 'D' and 'A',
Fix 'K' and 'L' in Nº 09 with 'C' and 'A'.
Fix H' with 'R'.

Fije 11 con 'D' y 'A',
Fije 'K' y 'L' en Nº 09 con 'C' y 'A'.
Fije H' con 'R'.

N	04 und.	G	04 und.	H	04 und.
<p>Puxador Bola Handle Tirador</p>		<p>Parafuso 4,0 x 25 CC Phillips Screw 4,0 X 25CC Phillips Tornillo 4,0 X 25CC Phillips</p>		<p>Cantoneira Triang. 14x14 mm Corner Brace 14 x 14 mm Abrazadera Metalica 14 x 14 mm</p>	
F	08 und.	L	04 und.	R	04 und.
<p>Cantoneira Bicromatizada Bicromatizada Corner Brace Abrazadera Bicromatizada</p>		<p>Corrediça 350 mm Sliding rails 350 mm Rieles 350 mm</p>		<p>Parafuso 4,0 x 16 CC Phillips Screw 4,0 x 16 CC Phillips Tornillo 4,0 x 16 CC Phillips</p>	
E	16 und.	A	36 und.	B	16 und.
<p>Cavilha 6 x 30 Dowel 6 x 30 Clavija 6 x 30</p>		<p>Parafuso 3,0 x 20 CC Phillips Screw 3,0 X 20CC Phillips Tornillo 3,0 X 20CC Phillips</p>		<p>Parafuso 4,0 x 40 CC Phillips Screw 4,0 X 40CC Phillips Tornillo 4,0 X 40CC Phillips</p>	
K	04 und.	C	32 und.	D	24 und.
<p>Corrediça 350 mm Sliding rails 350 mm Rieles 350 mm</p>		<p>Parafuso 3,0 x 10 CC Phillips Screw 3,0 X 10CC Phillips Tornillo 3,0 X 10CC Phillips</p>		<p>Prego 8 X 8 Nail 8 x 8 Clavo 8 x 8</p>	

Passo / Step / Paso 7:

Fixe a etiqueta Móveis Estrela

utilizando a Sanefa **utilizando**.

Fix **utilizando**.

Fixe **utilizando**.

01 und.

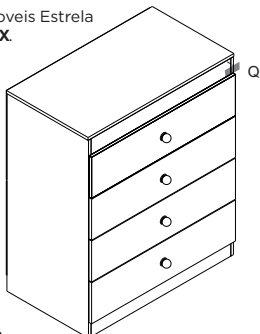

M.E. GONÇALVES
INDÚSTRIA DE MÓVEIS LTDA.
Avenida Maracaná, 4800 - Parque Industrial
Arapongas - PR - Brasil
Fone: +55 (43) 3274-8800
www.moveisestrela.com.br

MANUAL DE INSTRUÇÕES

MANUAL DE INSTRUCCIONES

INSTRUCTION MANUAL

CERTIFICADO

90
dias

GARANTIA

CÔMODA FANTASY BABY TRELIÇA - 8A
CÔMODA FANTASY BABY RIPADO - 8A
CÔMODA FANTASY BABY CAPITONÊ - 8A
CÔMODA FANTASY BABY TELINHA - 8A

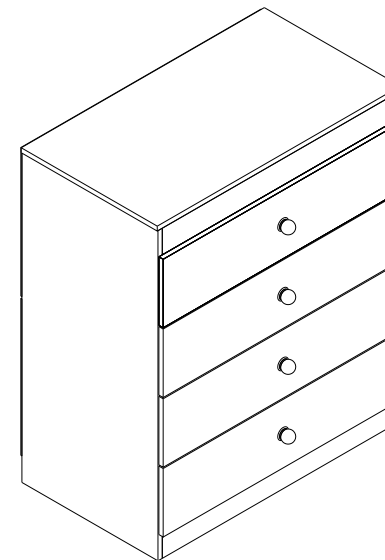

Móveis Estrela

SUA CASA, SEU ESTILO

"Imagens meramente ilustrativas, sujeitas a alterações sem aviso prévio"

"Image merely illustrative, subject to change without prior notice"

"Imágenes ilustrativas, pueden ser cambiadas sin aviso previo"



1 Adulto
1 Adult

Pessoas Necessárias para montagem

Necessary people for assembly

Gente necesaria para la asamblea

Ferramentas Necessárias (Não Inclusas)

Tools needed (not included)

Herramientas necesarias (no incluido)



Martelo
hammer
martillo



Parafusadeira
Screwdriver
destornillador



Chave Fenda
Slot Key
Clave de runura



Chave Phillips
Phillips Key
Clave Phillips

INFORMAÇÕES SOBRE SEGURANÇA

1. Esta embalagem contém peças pequenas, mantenha afastada de crianças até que o produto esteja montado.
2. As instruções são genéricas, as figuras podem variar.
3. Leia atentamente todas as instruções antes de iniciar a montagem.
4. Separe e guarde a etiqueta de identificação.
5. Confira se os volumes e quantidades de peças descritos no manual estão corretos.
6. Identifique as peças e separe os acessórios.
7. A montagem do produto deverá ser feita em uma superfície limpa e plana. Aconselhamos utilizar a própria embalagem para forrar o chão a fim de não danificar o produto.
8. Reservar área livre para montagem do produto.
9. Evitar batidas e o contato com objetos cortantes.
10. Não expor o móvel a um calor excessivo (luz solar direta), ou umidade elevada.
11. Para limpeza use um pano macio seco ou ligeiramente umedecido com água. Não use agentes de limpeza ou abrasivos.

SAFETY INFORMATION

1. This package contains small parts, keep away from children until the product is assembled.
2. The instructions are generic, the figures may vary.
3. Read all instructions carefully before starting assembly.
4. Separate and store the ID tag.
5. Check if the volumes and quantities of pieces described in the manual are correct.
6. Identify the pieces and separate accessories.
7. The assembly of the product shall be made on a clean and flat surface. We recommend using the package itself to cover the floor in order not to damage the product.
8. Reserve a specific area to assemble the product.
9. Avoid shocks and contact with sharp objects.
10. Do not expose the furniture to excessive heat (direct sunlight), or high humidity.
11. For cleaning use a dry soft cloth or slightly moistened with water. Do not use cleaning agents or abrasives

INFORMACIÓN DE SEGURIDAD

1. Este paquete contiene piezas pequeñas, mantenga alejado de los niños hasta que el producto esté montado.
2. Las instrucciones son genéricas, los dibujos pueden variar.
3. Lea todas las instrucciones cuidadosamente antes de empezar el montaje.
4. Separar y almacenar la etiqueta de identificación.
5. Verifique si los volúmenes y cantidades de las piezas descritas en el manual están correctas.
6. Identificar las piezas y separar los accesorios.
7. El montaje del producto se efectuará sobre una superficie limpia y plana. Se recomienda usar el propio envase para cubrir el suelo con el fin de no dañar el producto.
8. Reserve una área específica para el montaje del producto.
9. Evitar los golpes y el contacto con objetos afilados.
10. No exponga el mueble a un calor excesivo (luz solar directa), o alta humedad.
11. Para la limpieza utilice un paño suave y seco o ligeramente humedecido con agua. No utilice productos de limpieza o abrasivos

Passo / Step / Paso 3:

Prepare o Rodapé Frontal e Traseiro u **IRV** e **IRW** utilizando cavilhas **06**
Fixe o rodapé u **IRV** e u **IRW** na lateral u **IRSE** u **IRTE** utilizando cantoneira bicromatizada **05** com parafusos 3,0 x 10 CC Phillips **06**
Prepare a Sanefa u **IRX** utilizando cavilhas **06**
Fixe a peça u **IRX** nas peças u **IRSRTO**
Fixe a trava u **IRZ** na peça u **IRSRTO** utilizando cantoneira bicromatizada **05** e parafusos 3,0 x 10 CC Phillips **06**

Prepare N°04 and N°05 with 'E'.
Fix N°04 and N°05 in N°01 and N°02 with 'F' and 'C'.
Prepare N°06 with 'E'.
Fix N°06 in N°01 and 02,
Fix N°08 in N°01 and 02 with 'F' and 'C'.

Prepare N°04 and N°05 with 'E'.
Fix N°04 and N°05 in N°01 and N°02 with 'F' and 'C'.
Prepare N°06 with 'E'.
Fix N°06 in N°01 and 02,
Fix N°08 in N°01 and 02 with 'F' and 'C'.

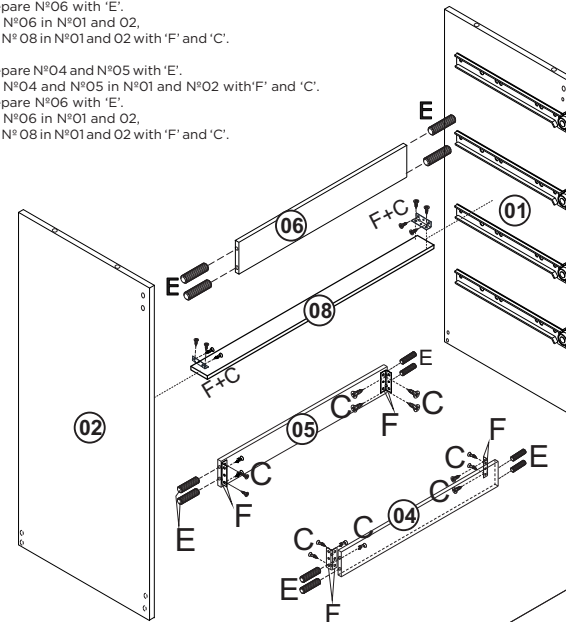

C	24 und.	E	12 und.	F	06 und.
Parafuso 3,0 x 10 CC Phillips Screw 3,0 X 10CC Phillips Tornillo 3,0 X 10CC Phillips		Cavilha 6 x 30 Dowel 6 x 30 Clavija 6 x 30		Cantoneira Bicromatizada Bicromatizada Corner Brace Abrazadera Bicromatizada	

Dependendo da cor escolhida, o montador deve inverter o lado da peça n° 06 ou colocar a peça n° 05 no lugar da sanefa (peça 06).

Depending on the chosen color, the assembler must reverse side of the part n° 06 or place the piece No. 05 in place of the part 06.

Dependiendo del color elegido, el ensamblador debe invertir lado de la pieza n° 06, o poner la pieza 05 en Lugar de la pieza 06

OBS: Não fixar acessório no lado pintado da peça n° 05, pois o mesmo oferece opção de montagem futura.

NOTE: Don't fix accessory in the painted side of the piece No. 05, because it offers future assemble option

NOTA: No fijar el accesorio en el lado pintado de la pieza N° 05, ya que ofrece la opción de montar futuro

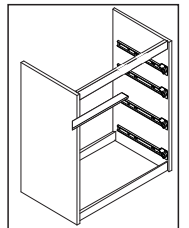

Passo / Step / Paso 4:

Fixe o Tampo u **IRU** na lateral u **IRSE** u **IRTE** utilizando cantoneira bicromatizada **05** com parafusos **06**

Fix N°03 in N°01 and N°02 with 'F' and 'C'.

Fije N°03 en N°01 y N°02 con 'F' y 'C'.

C	16 und.	F	04 und.
Parafuso 3,0 x 10 CC Phillips Screw 3,0 X 10CC Phillips Tornillo 3,0 X 10CC Phillips		Cantoneira Bicromatizada Bicromatizada Corner Brace Abrazadera Bicromatizada	

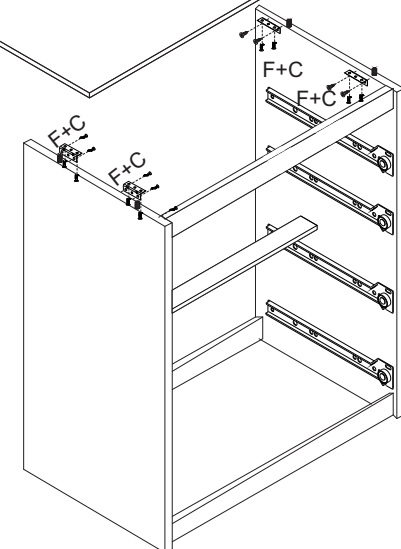
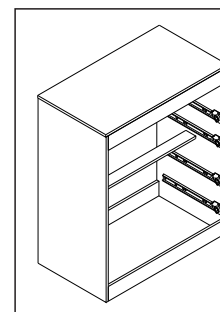



Passo / Step / Paso 1:

Fixe as corredeiras **uIRS** na lateral direita utilizando parafusos 3,0 x 10 CC Phillips $\phi 6$
 Fixe as cavilhas **uRSQ** no topo da peça **uIRSQ**

Fix 'J' in N°01 with 'C'.
 Fix 'E' in N°01.

Fije 'J' en N°01 con 'C'.
 Fije 'E' en N°01.

C	16 und.	E	02 und.
			
Parafuso 3,0 x 10 CC Phillips Screw 3,0 X 10CC Phillips Tomillo 3,0 X 10CC Phillips		Cavilha 6 x 30 Dowel 6 x 30 Clavija 6 x 30	
J	04 und.		
			
Correção 350 mm Sliding rails 350 mm Rieles 350 mm			

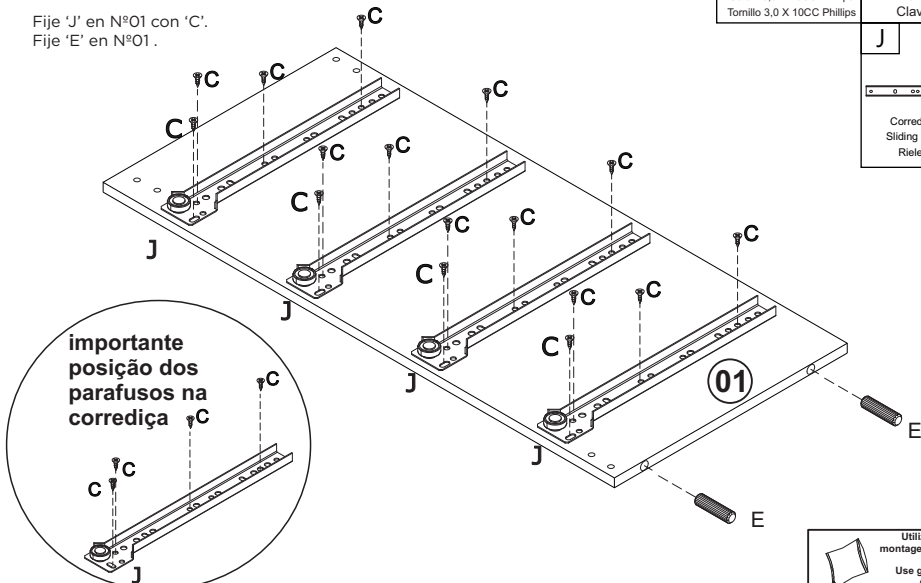



Utilizar cola na montagem das cavilhas
 Use glue with the dowels
 Utilizar el pegamento en las clavijas

Passo / Step / Paso 2:

Fixe as corredeiras **uIRT** na lateral esquerda utilizando parafusos 3,0 x 10 CC Phillips $\phi 6$
 Fixe as cavilhas **uRSQ** no topo da peça **uIRTQ**

Fix 'I' in N°02 with 'C'.
 Fix 'E' in N°02.

Fije 'J' en N°01 con 'C'.
 Fije 'E' en N°01.

C	16 und.	E	02 und.
			
Parafuso 3,0 x 10 CC Phillips Screw 3,0 X 10CC Phillips Tomillo 3,0 X 10CC Phillips		Cavilha 6 x 30 Dowel 6 x 30 Clavija 6 x 30	
I	04 und.		
			
Correção 350 mm Sliding rails 350 mm Rieles 350 mm			

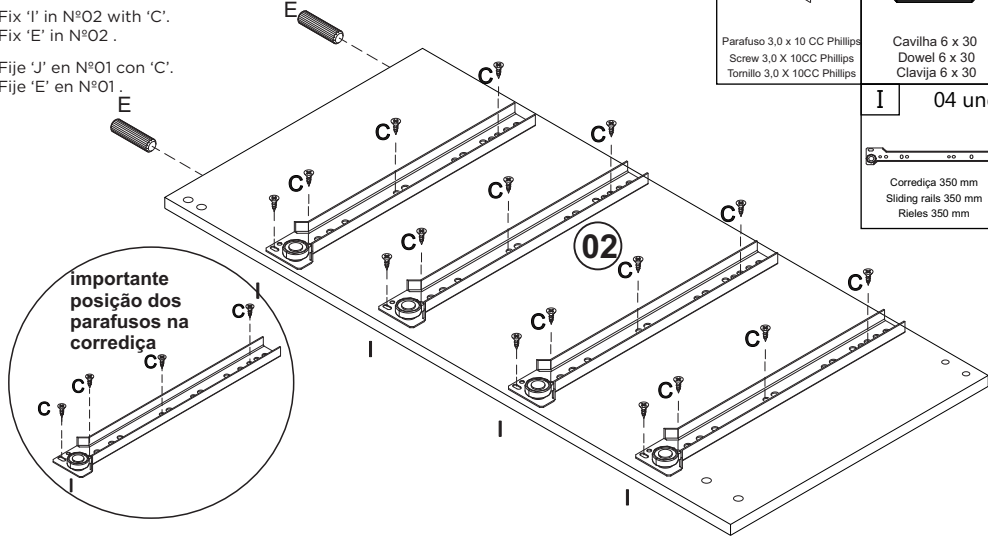

PESO SUPORTADO / DIMENSÕES DO PRODUTO MONTADO
 SUPPORTED WEIGHT / DIMENSIONS ASSEMBLED PRODUCT
 PESO SOPORTADO/ DIMENSIONES PRODUCTO ARMADO

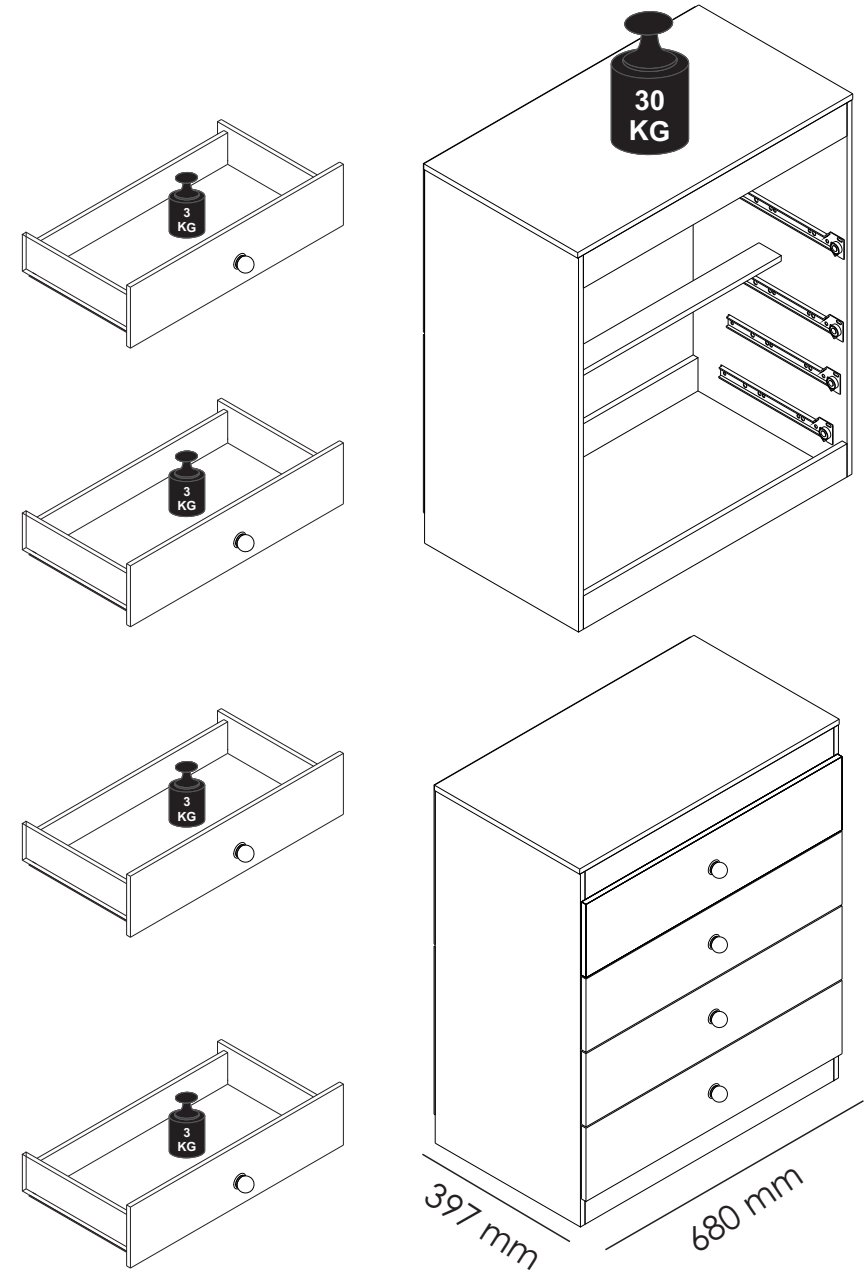

IDENTIFICAÇÃO DAS PEÇAS / IDENTIFICATION OF PARTS / IDENTIFICACIÓN DE LAS PIEZAS

CÓD.	IDENTIFICAÇÃO DAS PEÇAS	IDENTIFICATION OF PARTS	IDENTIFICACIÓN DE LAS PIEZAS	CÓDIGO		
				PROD	COR	QTD
01	Lateral Direita	Right Side	Lado Derecho	---	---	01
02	Lateral Esquerda	Left Side	Lado Izquierdo	---	---	01
03	Tampo	Surface	Tapa	---	---	01
04	Rodapé Frontal	Front Footer	Rodapie frontal	---	---	01
05	Rodapé Traseiro	Back Footer	Rodapie trasero	---	---	01
06	Sanefa (Rosa/Azul)	Top Panel (Pink/Blue)	Panel superior	---	---	01
07	Frente da Gaveta	Drawer Front	Frente del cajón	---	---	04
08	Trava	Lock bar	Bloqueo	---	---	01
09	Lateral da Gaveta	Drawer side	Lado del cajón	---	---	08
10	Contra Fundo	Drawer back	Trasera de cajón	---	---	04
11	Fundo da Gaveta	Drawer bottom	Fondo del cajón	---	---	04
12	Fundo Traseiro A	Back bottom A	Fondo trasero A	---	---	01
13	Fundo Traseiro B	Back bottom B	Fondo trasero B	---	---	01

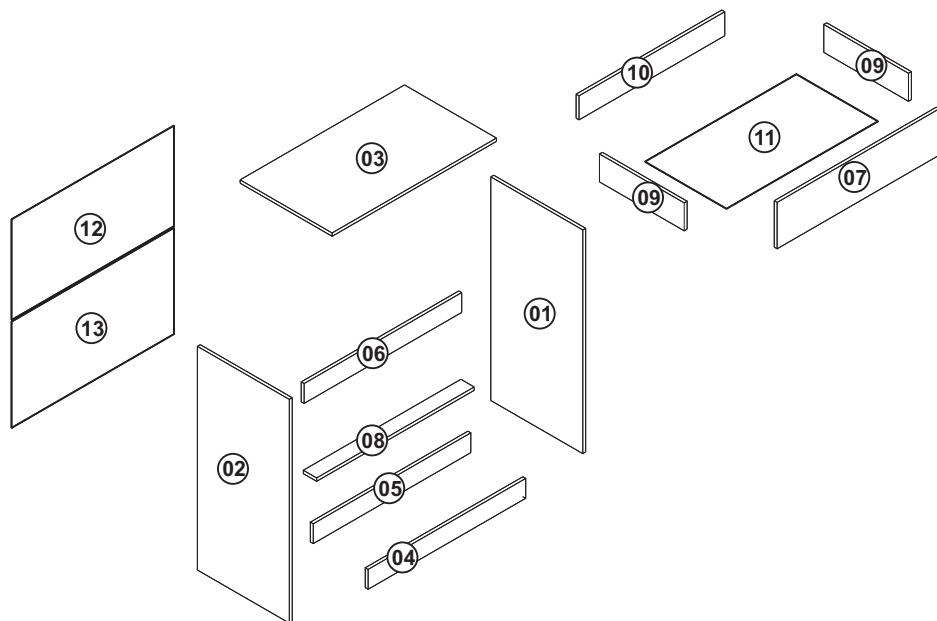

ASSISTÊNCIA TÉCNICA

Ao solicitar assistência técnica, informe o número da peça, nome e cor do produto e a data de fabricação do lote que se encontra carimbado na peça n° 07.











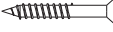





TECHNICAL ASSISTANCE

When request the technical assistance, please inform the number of the piece name and color of the product and also the batch manufacturing date, that is stamped on the piece n° 07.

ASISTENCIA TÉCNICA

Al solicitar la asistencia técnica, informe el número de la pieza, el nombre y el color del producto y también la fecha de fabricación del lote, que se estampa en la pieza n° 07

FERRAGENS / IRONMONGERY / HERRAJES

A 36 und.	B 16 und.	C 104 und.	D 58 und.	E 32 und.	F 18 und.	G 04 und.
 Parafuso 3.0 x 20 CC Phillips Screw 3.0 X 20CC Phillips Tornillo 3.0 X 20CC Phillips	 Parafuso 4.0 x 40 CC Phillips Screw 4.0 X 40CC Phillips Tornillo 4.0 X 40CC Phillips	 Parafuso 3.0 x 10 CC Phillips Screw 3.0 X 10CC Phillips Tornillo 3.0 X 10CC Phillips	 Prego 8 X 8 Nail 8 x 8 Clavija 6 x 8	 Cavilha 6 x 30 Dowel 6 x 30 Clavija 6 x 30	 Cantoneira Bicromatizada Bicromatizada Corner Brace Abrazadera Bicromatizada	 Parafuso 4.0 x 25 CC Phillips Screw 4.0 X 25CC Phillips Tornillo 4.0 X 25CC Phillips
H 04 und.	I 04 und.	J 04 und.	K 04 und.	L 04 und.	M 04 und.	N 04 und.
 Cantoneira Triang. 14x14 mm Corner Brace 14 x 14 mm Abrazadera Metalica 14 x 14 mm	 Corrediça 350 mm Sliding rails 350 mm Rieles 350 mm	 Corrediça 350 mm Sliding rails 350 mm Rieles 350 mm	 Corrediça 350 mm Sliding rails 350 mm Rieles 350 mm	 Corrediça 350 mm Sliding rails 350 mm Rieles 350 mm	 Sapata Lateral Side shoes Zapata lateral	 Puxador Bola Handle Tirador
O 02 und.	P 01 und.	Q 01 und.	R 04 und.			
 Cola Glue Pegamento	 Perfil H 649 mm H Perfil 649 mm Perfil H 649 mm	 Etiqueta Label Etiqueta	 Parafuso 4.0 x 16 CC Phillips Screw 4.0 x 16 CC Phillips Tornillo 4.0 x 16 CC Phillips			

FERRAGENS ESCALA REAL / REAL SCALE IRONMONGERY / HERRAJES EN TAMAÑO COMPLETO

