

PRODUTO CONCLUÍDO
PRODUCTO TERMINADO
FINISHED PRODUCT

ITM/D337-
REV. 003



HENN

Ind. e Com. de Móveis Henn
Mondai - SC - Brasil

+55 49 3674.3500

@moveishenn
www.henn.com.br

ITM/D337-
**INSTRUÇÕES DE
MONTAGEM**

INSTRUCCIONES DE MONTAJE
ASSEMBLY INSTRUCTIONS

ROUPEIRO CAYMAN 02 PORTAS |
ARMARIO CAYMAN 02 PUERTAS | WARDROBE CAYMAN 02 DOORS

D337-127 Nature/Off White

D337-128 Nature

D337-214 Cinamomo

D337-221 Cinamomo/Off White

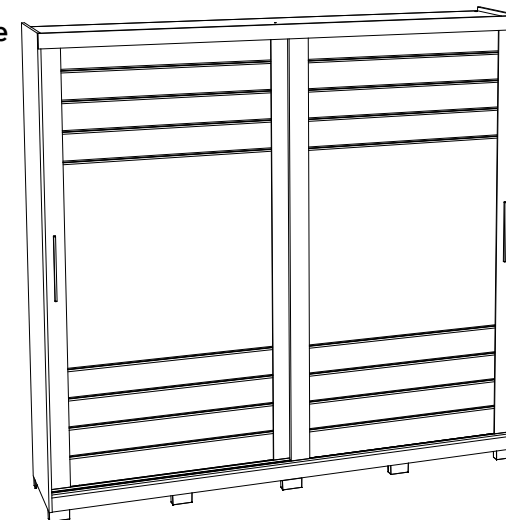

AVISO

Para limpeza de seu móvel, use uma flanela seca ou umedecida, e não utilize produtos químicos que possam danificar seu produto.

SISTEMA DE MONTAGEM

O sistema de montagem dos produtos, funciona de acordo com a ordem crescente dos números indicados no desenho. Ex: 01, 02, 03, 04... até a conclusão da montagem.

ASSISTÊNCIA TÉCNICA

Para solicitação de Assistência Técnica você consumidor deverá entrar em contato com o Lojista o qual você realizou a compra deste produto e solicitar a assistência técnica das peças avariadas. A garantia abrange todas as peças, partes e componentes que eventualmente venham apresentar defeito de fabricação no prazo de 03 (três) meses, contando a partir da entrega do produto ao consumidor, mediante nota fiscal de compra. Se houver qualquer alteração na estrutura do produto ou ocorrer defeito por negligência do montador/consumidor em relação a instrução de montagem e manuseio, não será fornecido assistência técnica gratuita.

ADVERTENCIA

Para limpieza de su móvil, use una flanela seca o húmeda, y no utilice productos químicos que puedan dañar su producto.

SISTEMA DE MONTAJE

El sistema de montaje de los productos funciona de acuerdo con el orden creciente de los números indicados en el dibujo. Ej.: 01, 02, 03, 04... hasta la conclusión del montaje.

ASISTENCIA TÉCNICA

Para solicitar Asistencia Técnica, el consumidor debe comunicarse con el Comercio que usted realizó la compra de este producto y solicita asistencia técnica para las partes dañadas. La garantía cubre todas las partes, piezas y componentes que eventualmente puedan presentar defecto de fabricación en el plazo de 03 (tres) meses, contados a partir de la entrega del producto al consumidor, mediante factura de compra. Si se produce algún cambio en la estructura del producto o se produce un defecto por negligencia del montador/consumidor en relación con las instrucciones de montaje y manipulación, no se prestará asistencia técnica gratuita.

NOTICE

To clean your furniture, use a dry or wet cloth, and do not use chemicals that may damage your product.

ASSEMBLY SYSTEM













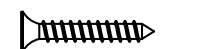

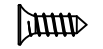

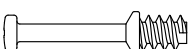
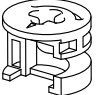
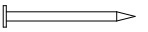
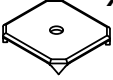

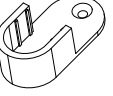
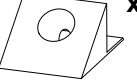
The products' assembly system works according to the increasing order of the indicated numbers. For example: 01, 02, 03, 04 ... to the end of the assembly.

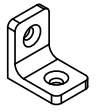
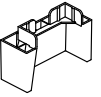
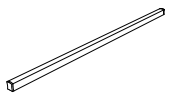
TECHNICAL ASSISTANCE

To request Technical Assistance, the consumer must contact the retailer from whom you purchased this product and request technical assistance for the damaged parts. The warranty covers all parts, parts and components that may eventually present a manufacturing defect within a period of 03 (three) months, counting from the delivery of the product to the consumer, by means of a purchase invoice. If there is any change in the structure of the product or defect occurs due to negligence of the assembler/consumer in relation to the assembly and handling instruction, free technical assistance will not be provided.

ACESSÓRIOS | ACCESORIOS | ACCESSORIES

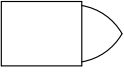
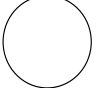
ITM/D337-

A x8  Parafuso 4,5x50mm CHT.	B x47  Parafuso 4,0x45mm CHT.	C x6  Parafuso 3,5x30mm FLA.	D x32  Parafuso 3,5x22mm CHT.
E x12  Parafuso 3,0x16mm CHT.	F x225  Parafuso 3,5x12mm CHT.	G x126  Cavilha 8x25mm.	H x3  Parafuso Minifix.
I x3  Tambor Minifix.	J x216  Prego 10x10.	K x75  Fixador de Fundos.	L x8  Porca Cilíndrica.
M x6  Suporte Cabideiro Oblongo.	N x12  Cantoneira Suporte Triangular.	O x32  Suporte de Metal.	P x25  Cantoneira Plástica.
Q x9  Pé "U" 50x40x100.	R x2  Puxador Goiano 321,5mm.	S PAR x6  Correção Telescópica 300x30mm.	T x1 KIT  Kit Roldana JP240 40R c 4 Guia 4 Freio 2 Estrela (2Pts)
U x3  Cadibreiro Alum. Oblongo 598mm.	V x2  Trilho Superior PVC 2468mm.	W x2  Trilho de Alumínio 2468mm.	X x3  Sache de Cola.
Y x2  Giz de Correção.	Z x4  Adesivo tapa Parafuso 17mm.	AA x38  Adesivo tapa Parafuso 10mm.	AB x1  Etiqueta Resinada Henn.

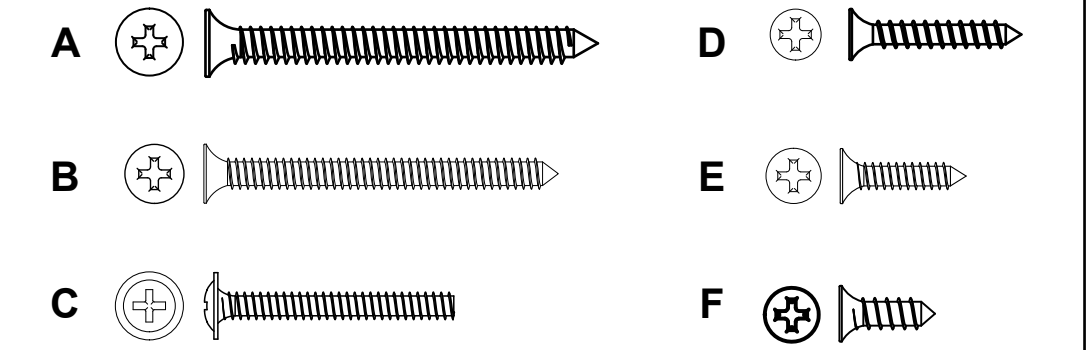





2 PARAFUSOS EM ESCALA 1:1 | TORNILLOS A ESCALA 1:1 | 1:1 SCALE SCREWS

MONTAGEM 11 | MONTAJE 11 | ASSEMBLY 11

ITM/D337-

ACESSÓRIOS REQUERIDOS

Y		02
Z		04
AA		38
AB		01

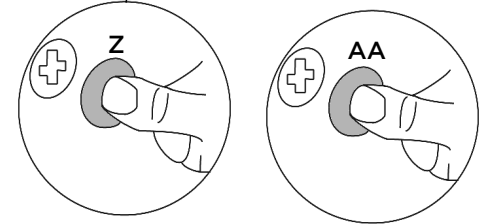
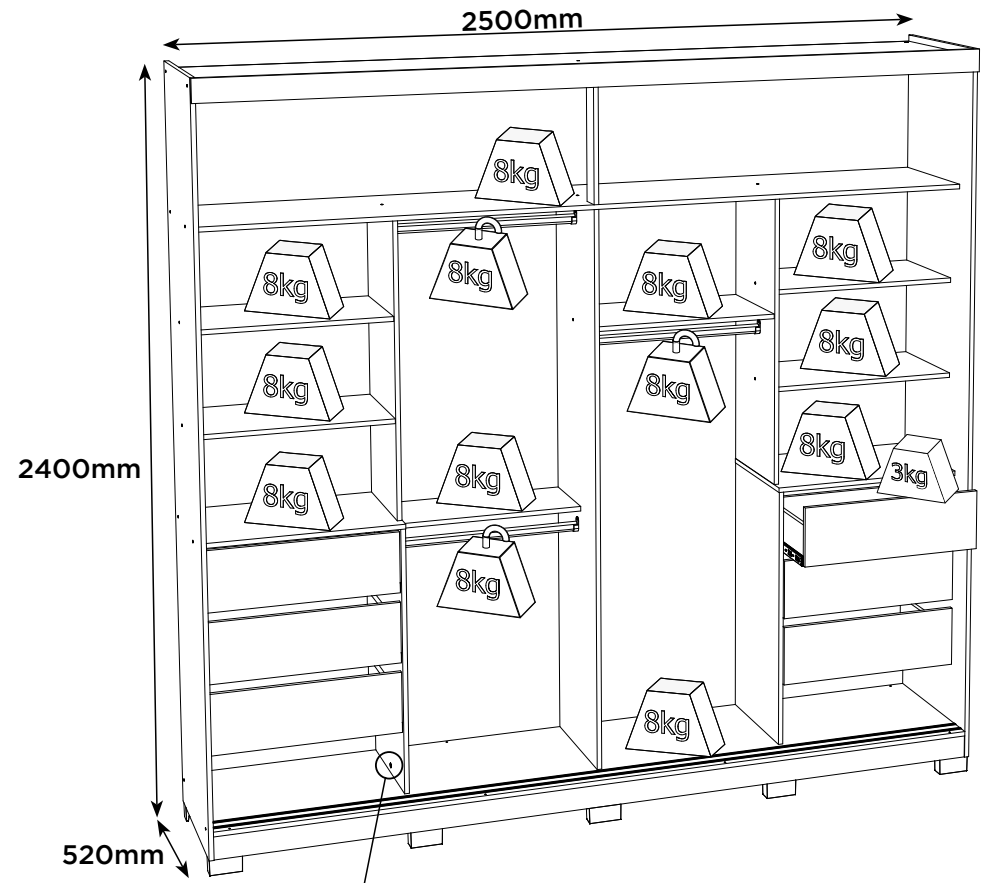

Pesos máximos recomendados com carga distribuída
Peso máximo recomendado con la carga distribuida
Recommended maximum weight with distributed load.

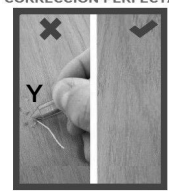

PERFECT CORRECTION
CORRECCIÓN PERFECTA



ACESSÓRIOS REQUERIDOS

U		03
V		02
W		02

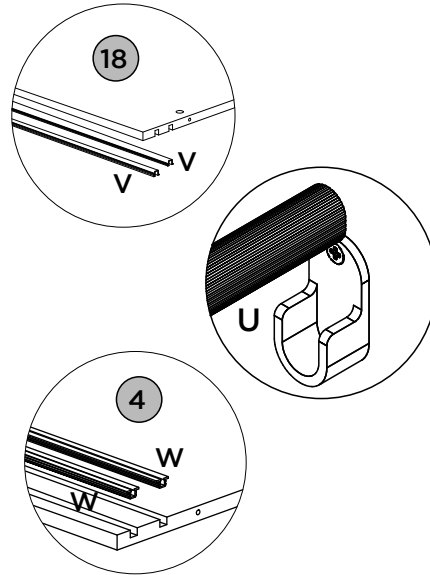
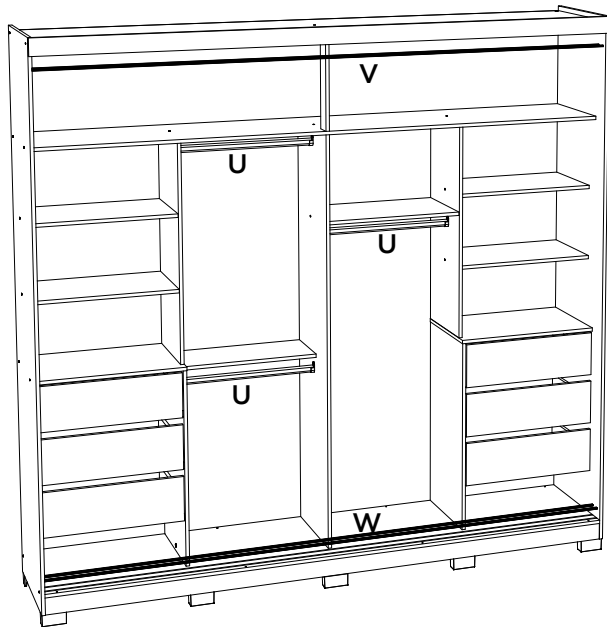

MONTAGEM 10 | MONTAJE 10 | ASSEMBLY 10

PEÇAS REQUERIDAS

27	PAINEL INFERIOR SUPERIOR	x4
28	PAINEL MENOR	x12
29	PAINEL MAIOR	x2
30	MOLDURA PORTA	x4

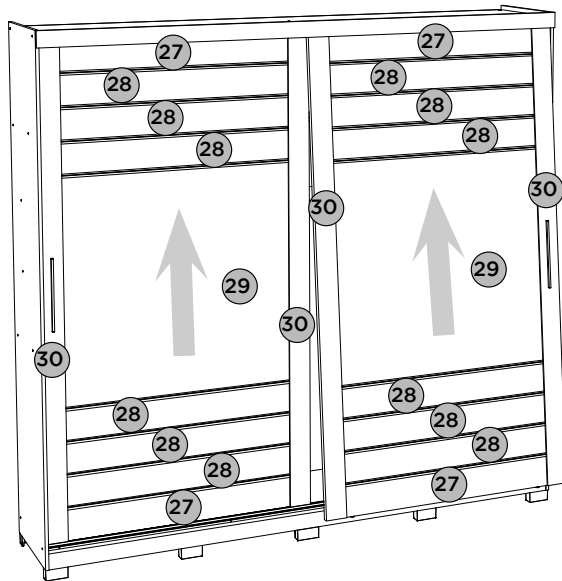

LISTA DE PEÇAS | LISTA DE PIEZAS | LIST OF PIECES

Item	Caixa Caja Box	Qty Ctd Qty	Descrição Descripción Description	100Dimensões (mm) Dimen- siones (mm) Dimensions (mm)		
				Compri- mento Largo Length	Largura Ancho Width	Espessura Grosor Thickness
1	2/5	1	RODAPÉ FRONTAL FALDÓN DELANTERO FRONT SKIRTING	2469	73	15
2	3/5	3	TRAVESSA DO RODAPÉ PLACA DE RODAPIÉ SKIRTING PLATE	464	73	15
3	2/5	1	RODAPÉ TRASEIRO REPOSAPIÉS TRASERO BACK FOOTBOARD	2469	73	15
4	2/5	1	BASE BASE BASE	2469	500	15
5	3/5	1	LATERAL ESQUERDA LATERAL IZQUIERDA LEFT SIDE	2350	500	15
6	1/5	1	DIVISÃO INFERIOR ESQUERDA DIVISIÓN INFERIOR IZQUIERDA BOTTOM LEFT DIVISION	841	400	15
7=13	4/5	1	TAMPO DAS GAVETAS TAPA DE LOS CAJONES TOP OF DRAWERS	622	400	15
8	1/5	1	DIVISÃO SUPERIOR ESQUERDA DIVISIÓN SUPERIOR IZQUIERDA UPPER LEFT DIVISION	941	355	15
9=15	4/5	2	PRATELEIRA ESTANTE SHELF	606	350	15
10	3/5	1	DIVISÃO DIVISIÓN DIVISION	1797	410	15
11	4/5	1	PRATELEIRA DO CALCEIRO ESTANTE DE CALCEIRO CALCEIRO'S SHELF	606	250	15
12	1/5	1	DIVISÃO INFERIOR DIREITA DIVISIÓN INFERIOR DERECHA LOWER RIGHT DIVISION	841	400	15
13=7	4/5	1	TAMPO DAS GAVETAS TAPA DE LOS CAJONES TOP OF DRAWERS	622	400	15
14	1/5	1	DIVISÃO SUPERIOR DIREITA DIVISIÓN SUPERIOR DERECHA UPPER RIGHT DIVISION	941	355	15
15=9	4/5	3	PRATELEIRA ESTANTE SHELF	606	350	15
16	3/5	1	CHÃO DO MALEIRO REPISA SUPERIOR FLOOR OF MALEIRO	2469	410	15
17	3/5	1	RIPA DO MALEIRO TRAVESAÑO SUPERIOR MALEIRO'S LATH	414	73	15
18	2/5	1	TAMPO TAPA TOP	2469	500	15
19	3/5	1	LATERAL DIREITA LADO DERECHO RIGHT SIDE	2350	500	15
20	2/5	1	CHAPÉU SOMBRERO HAT	2497	73	15
21	2/5	1	FUNDO SUPERIOR FONDO TOP TOP FUND	2489	437	3
22	3/5	4	FUNDO FONDO BOTTOM	1818	622	3
23	2/5	6	FRENTE DE GAVETA FRENTE DE CAJÓN FRONT OF DRAWER	598	192	15
24	1/5	12	LADO DE GAVETA LADO DEL CAJÓN SIDE OF DRAWER	350	122	15
25	5/5	6	FUNDO DE GAVETA RECORTADO FONDO DEL CAJÓN RECORTADO CROPPED DRAWER BOTTOM	562	361	3
26	1/5	6	RIPA DE TRÁS MALLA DETRÁS REAR LATH	581	122	15
27	5/5	4	PAINEL INFERIOR SUPERIOR PANEL INFERIOR SUPERIOR TOP BOTTOM PANEL	1075	146	12
28	5/5	12	PAINEL MENOR PANEL MENOR MINOR PANEL	1075	148	12
29	5/5	2	PAINEL MAIOR PANEL MAYOR LARGER PANEL	1075	1026	12
30	2/5	4	MOLDURA PORTA MARCO PUERTA DOOR FRAME	2210	100	25

VISTA EXPLODIDA DAS PEÇAS | VISTA DESPIECE DE LAS PIEZAS | EXPLODED VIEW OF THE PARTS.

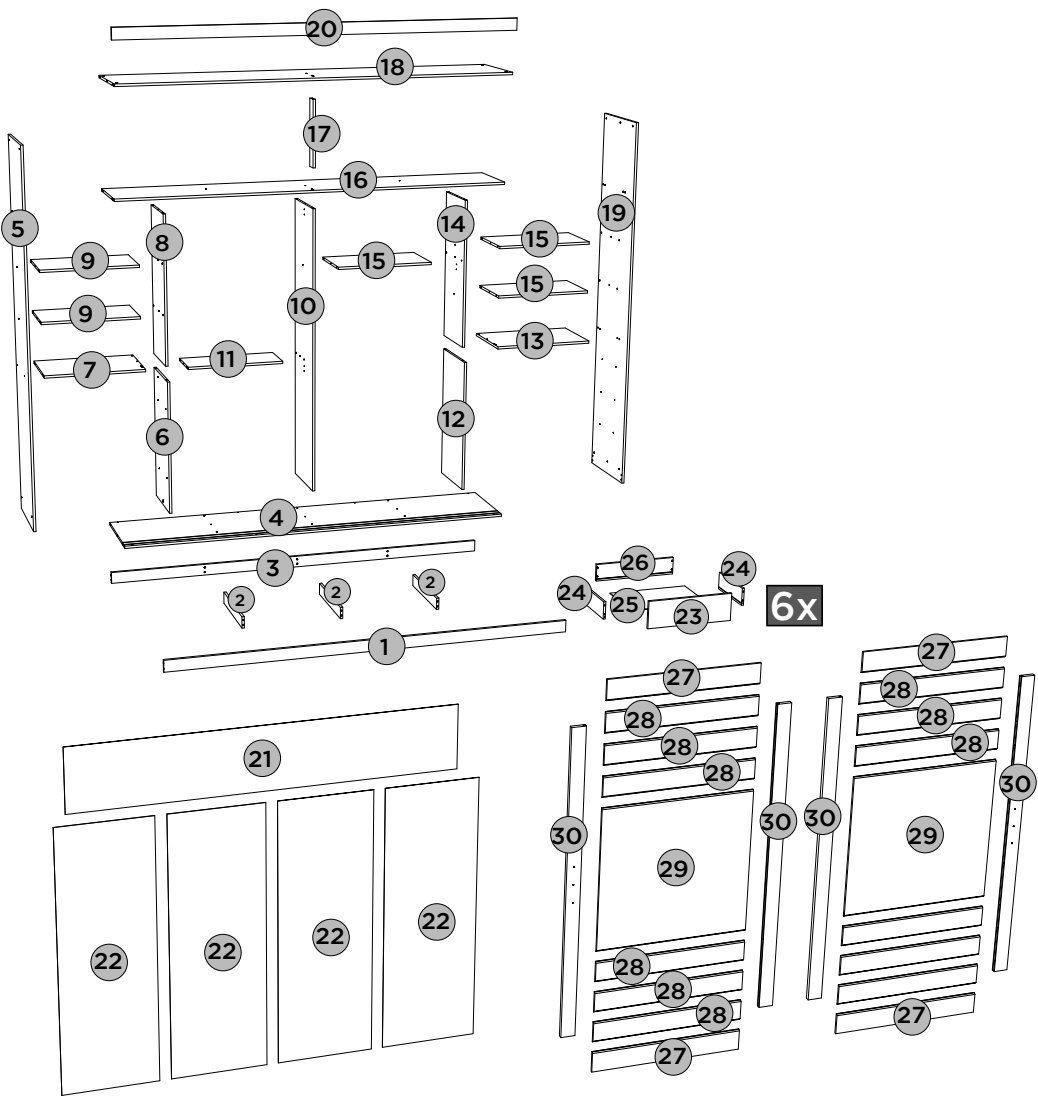

REQUISITOS PARA MONTAGEM
REQUISITOS PARA LA MONTAJE | ASSEMBLY REQUIREMENTS.

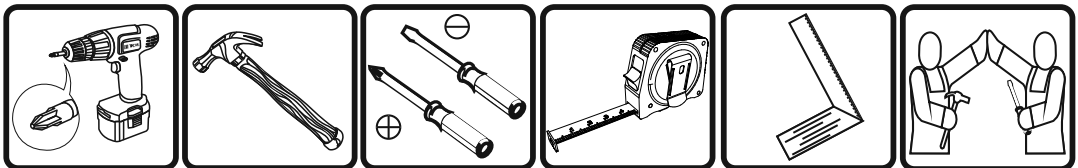

Imagens meramente ilustrativas, não acompanha o produto.
Imágenes ilustrativas, no incluidas con el producto.
Illustrative images, not included with the product.

MONTAGEM 8 | MONTAJE 8 | ASSEMBLY 8

PEÇAS REQUERIDAS

23	FRENTE DE GAVETA	x6
24	LADO DE GAVETA	x12
25	FUNDO DE GAVETA RECORTADO	x6
26	RIPA DE TRÁS	x6

ACESSÓRIOS REQUERIDOS

B		12
E		12
F		60
N		12

FERRAMENTAS NECESSÁRIAS

		X
P		12
S		06
X		

6x

1º

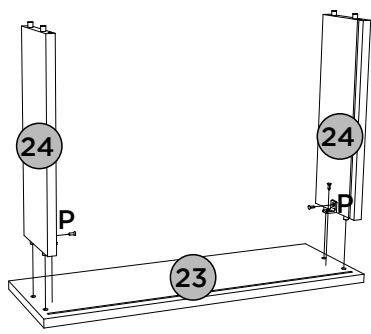

6x

2º

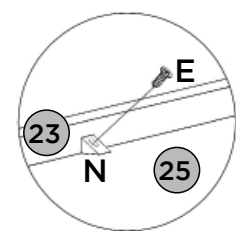
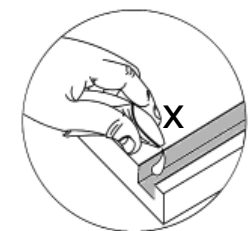
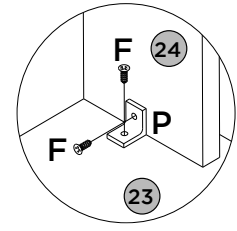
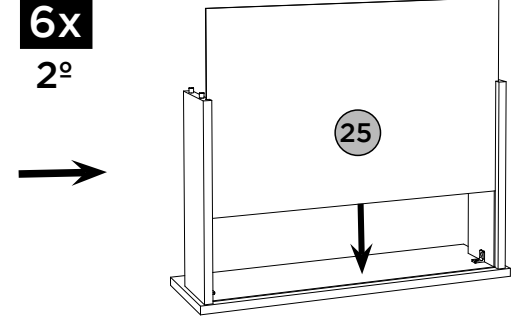

6x

3º

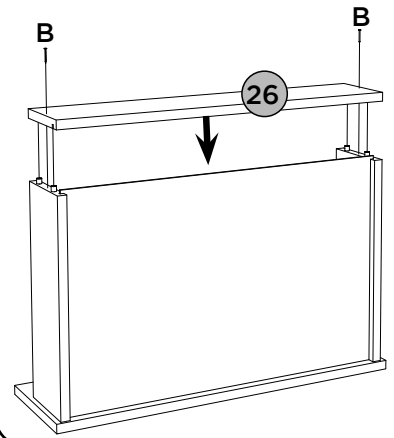

6x

4º

Deixar 3mm de distância da frente de gaveta.
Deje una separación de 3mm del frente del cajón.
Leave 3mm away from the front of the drawer.

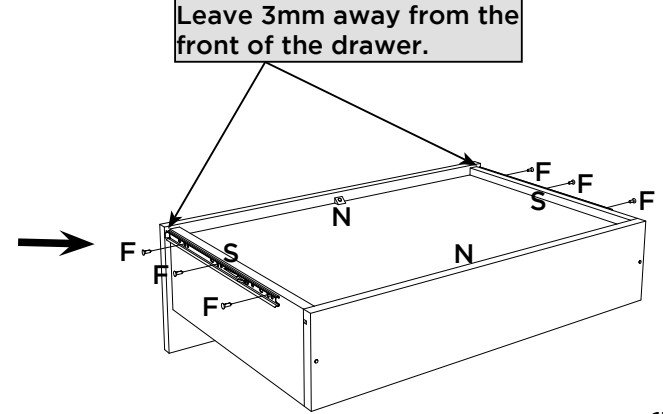

PEÇAS REQUERIDAS

20	CHAPÉU	x1
21	FUNDO SUPERIOR	x1
22	FUNDO	x4

ACESSÓRIOS REQUERIDOS

F		10
J		216
K		75
P		05

FERRAMENTAS NECESSÁRIAS

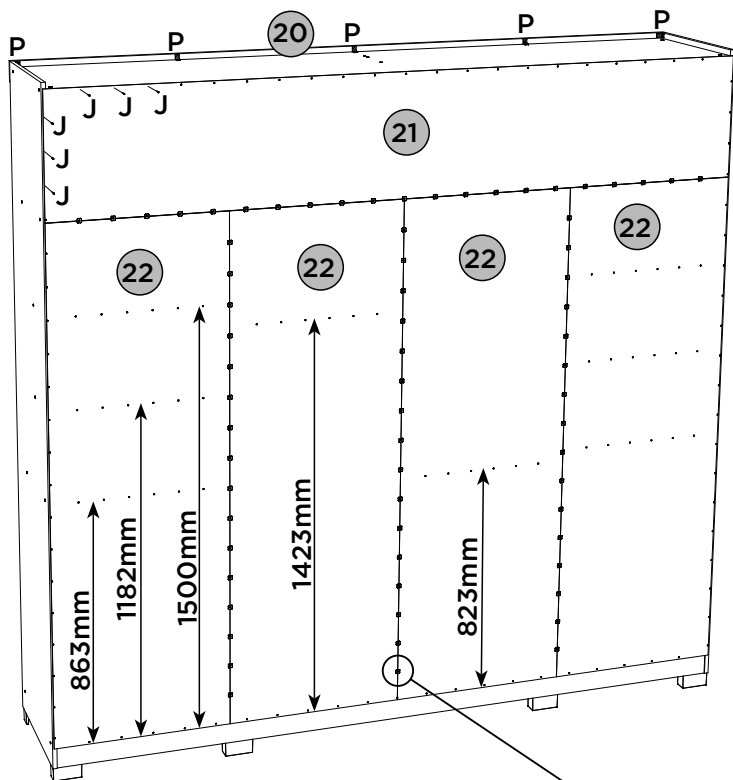
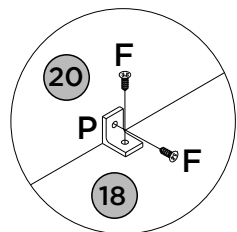
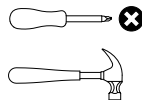

- Fixar os pregos a uma distância de 100mm de um para outro.
- Fijar las uñas a un distancia de 100mm uno a otro.
- Fix the nails at a distance of 100mm from one to the other

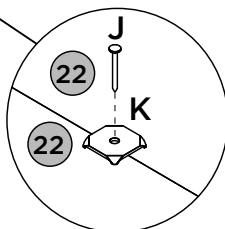

PEÇAS REQUERIDAS

1	RODAPÉ FRONTAL	x1
2	TRAVESSA DO RODAPÉ	x3
3	RODAPÉ TRASEIRO	x1
17	RIPA DO MALEIRO	x1

ACESSÓRIOS REQUERIDOS

F		06
G		22
P		06

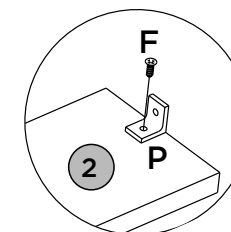
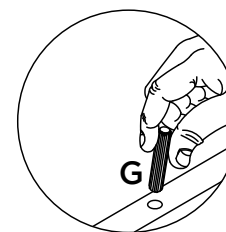
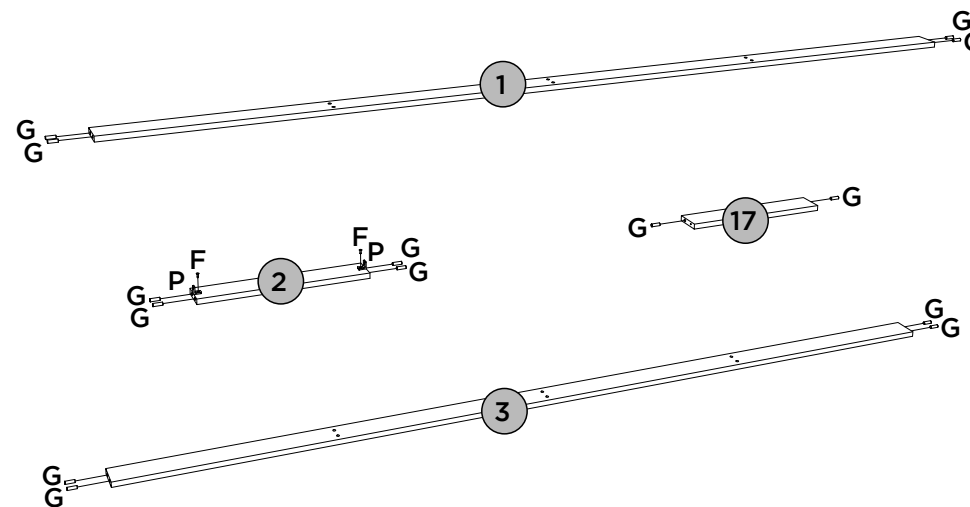
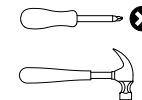

FERRAMENTAS NECESSÁRIAS



PEÇAS REQUERIDAS

4	BASE	x1
16	CHÃO DO MALEIRO	x1
18	TAMPO	x1

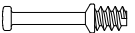
ACESSÓRIOS REQUERIDOS

G		08
H		03
L		08

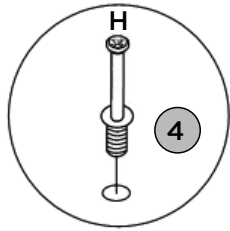
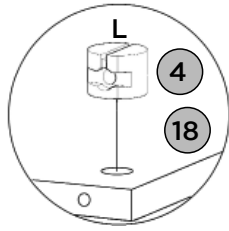
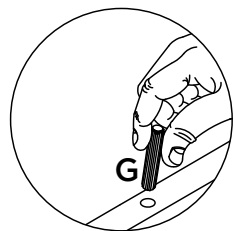
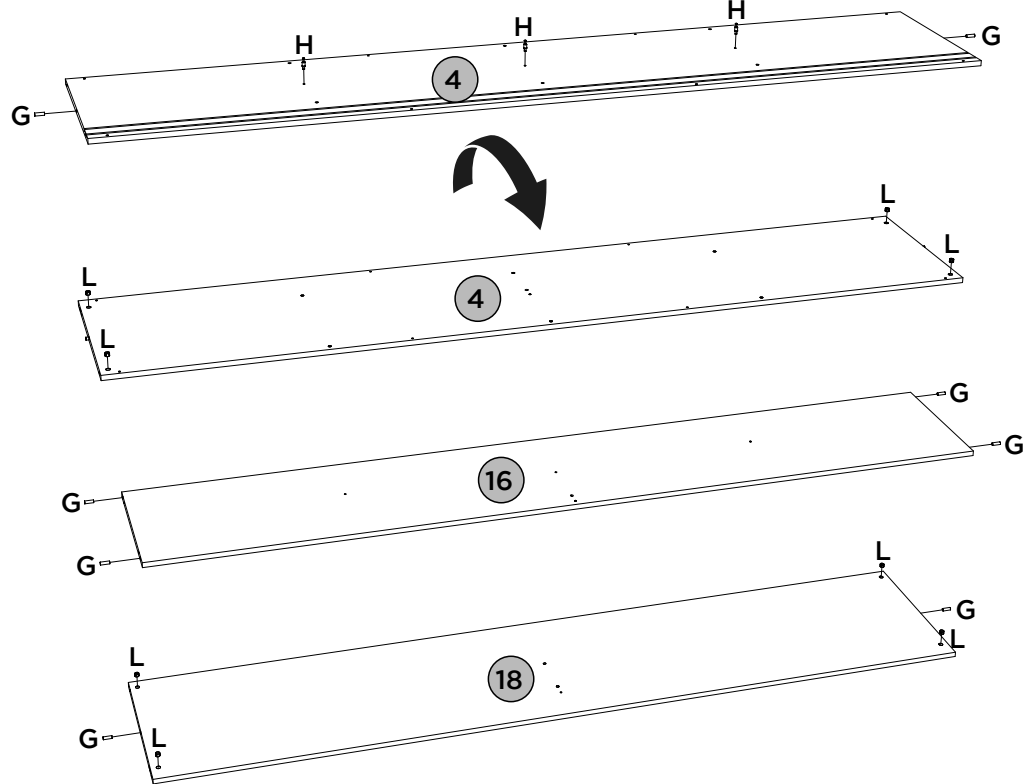
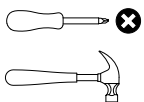

FERRAMENTAS NECESSÁRIAS



PEÇAS REQUERIDAS

15=9	PRATELEIRA	x2
16	CHÃO DO MALEIRO	x1
17	RIPA DO MALEIRO	x1
18	TAMPO	x1
19	LATERAL DIREITA	x1

ACESSÓRIOS REQUERIDOS

A		06
B		15

FERRAMENTAS NECESSÁRIAS

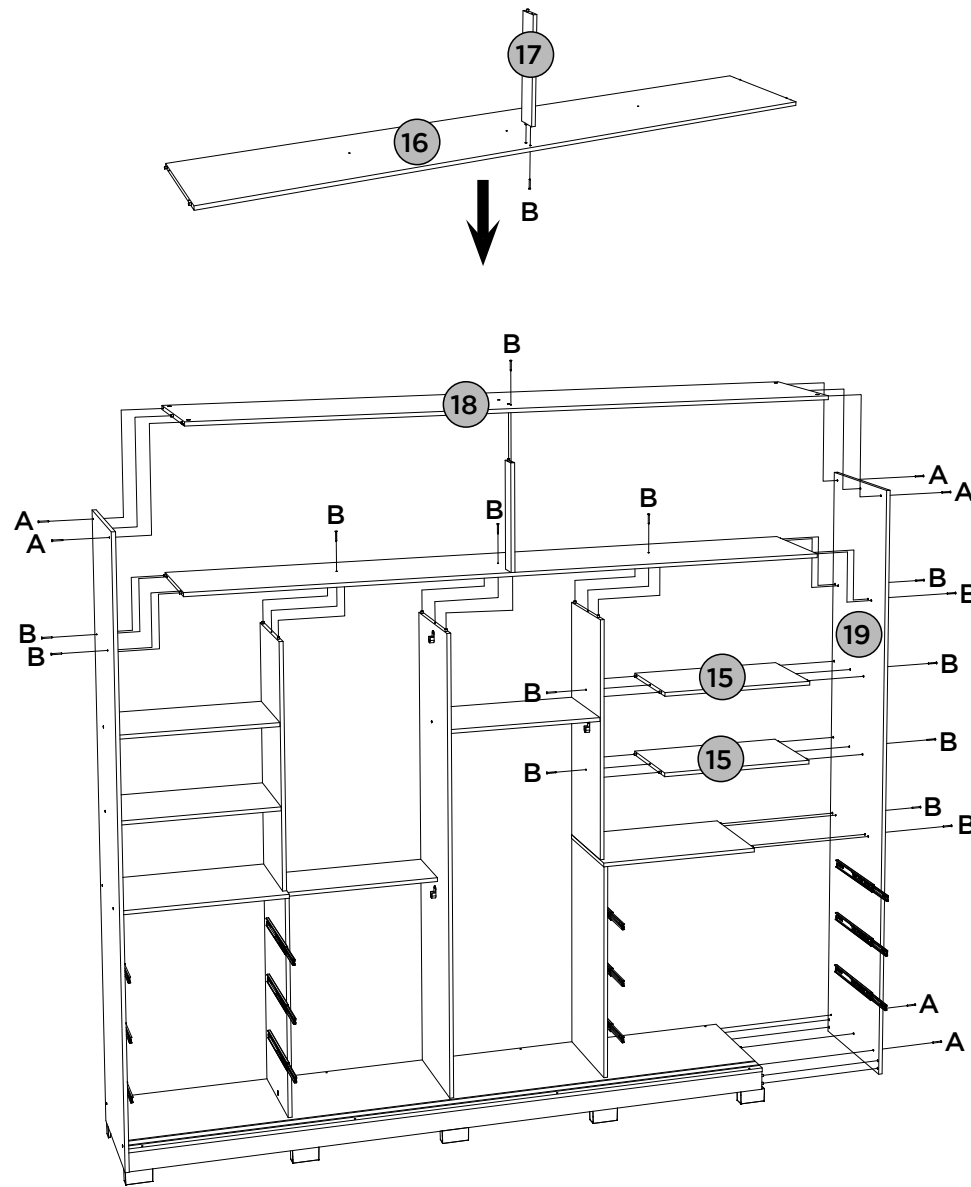
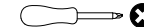

PEÇAS REQUERIDAS

13=7	TAMPO DAS GAVETAS	x1
14	DIVISÃO SUPERIOR DIREITA	x1
15=9	PRATELEIRA	x1

ACESSÓRIOS REQUERIDOS

B		03
F		02
P		01

FERRAMENTAS NECESSÁRIAS

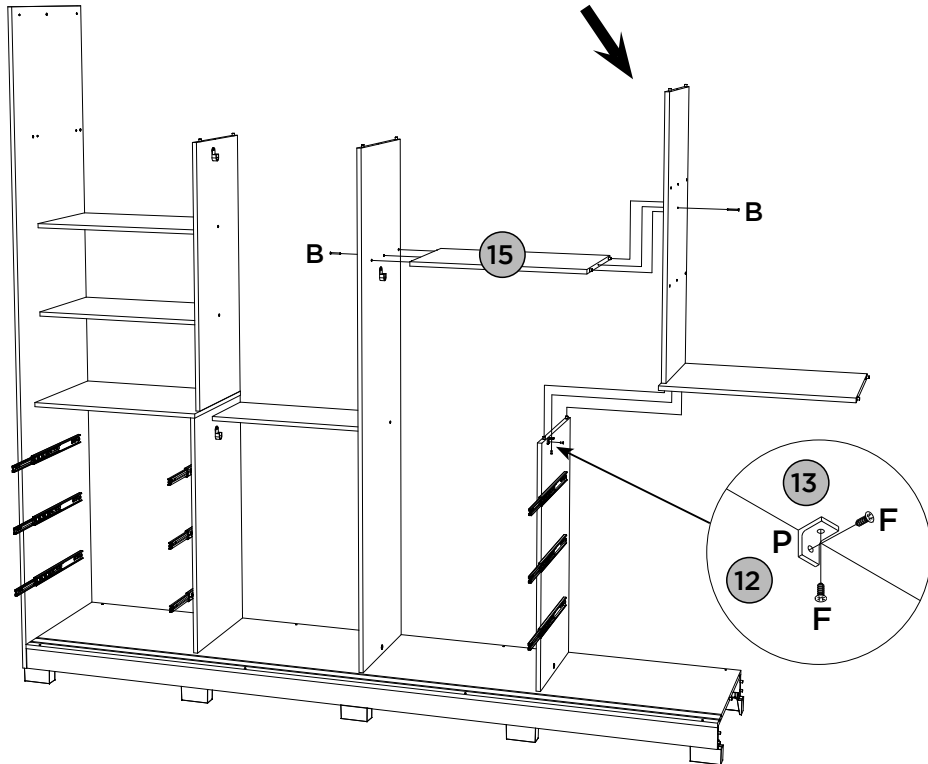
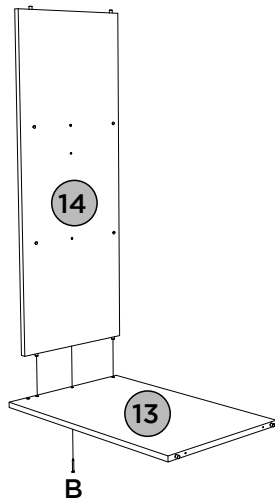
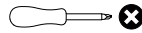

PEÇAS REQUERIDAS

5	LATERAL ESQUERDA	x1
6	DIVISÃO INFERIOR ESQUERDA	x1
12	DIVISÃO INFERIOR DIREITA	x1
19	LATERAL DIREITA	x1

ACESSÓRIOS REQUERIDOS

F		38
G		08
M		01
S		06

FERRAMENTAS NECESSÁRIAS

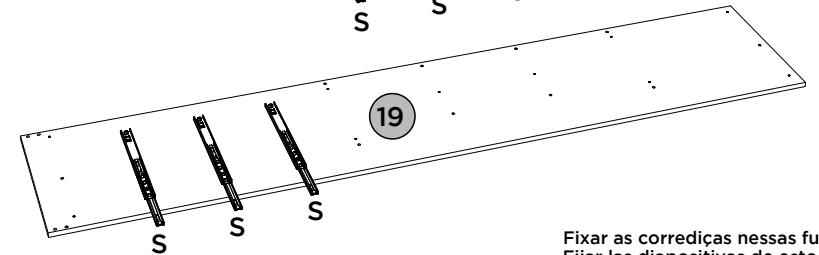
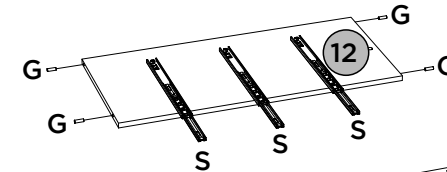
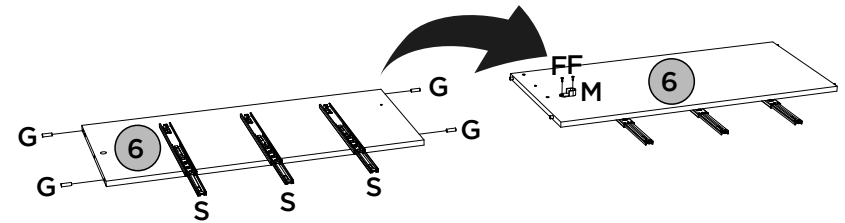
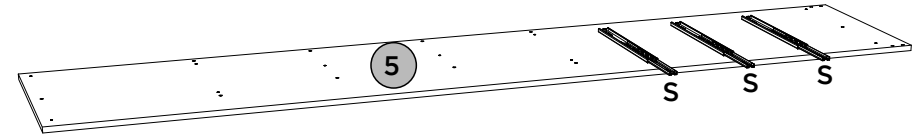
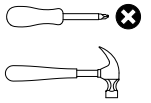

Fixar as corredeiras nessas furações
Fijar las diapositivas de estos agujeros
Fix the slides in these holes

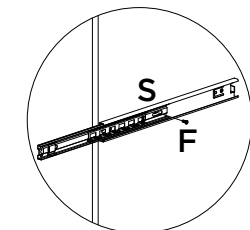
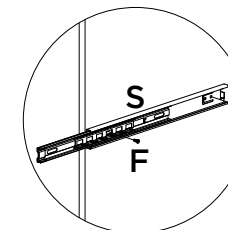
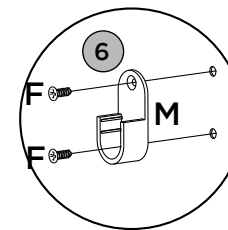
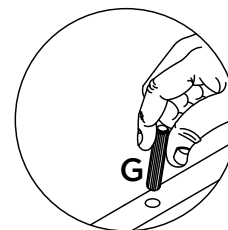
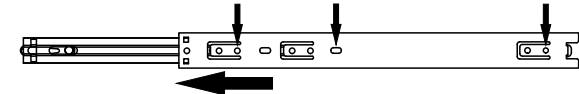

PEÇAS REQUERIDAS

ACESSÓRIOS REQUERIDOS

FERRAMENTAS NECESSÁRIAS

7=13	TAMPO DAS GAVETAS	x2
8	DIVISÃO SUPERIOR ESQUERDA	x1
9=15	PRATELEIRA	x5
10	DIVISÃO	x1
11	PRATELEIRA DO CALCEIRO	x1
14	DIVISÃO SUPERIOR DIREITA	x1

F		10
G		40
M		05

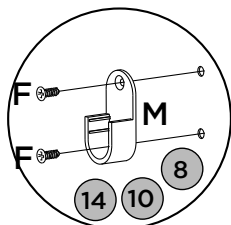
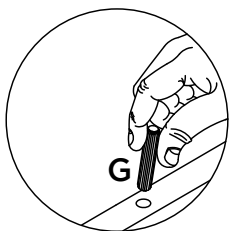
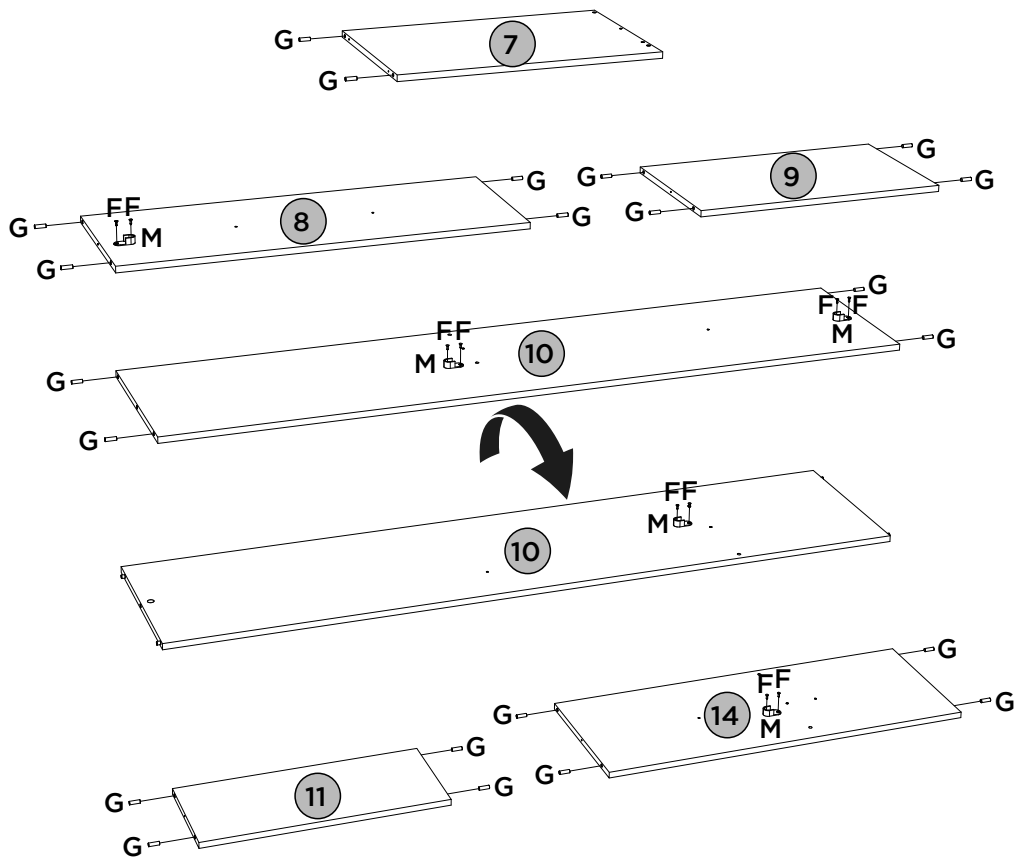
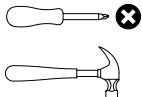

PEÇAS REQUERIDAS

ACESSÓRIOS REQUERIDOS

FERRAMENTAS NECESSÁRIAS

10	DIVISÃO	x1
11	PRATELEIRA DO CALCEIRO	x1
12	DIVISÃO INFERIOR DIREITA	x1

B		02
I		02

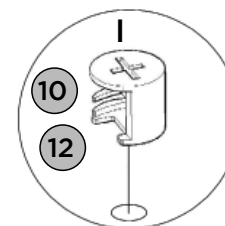
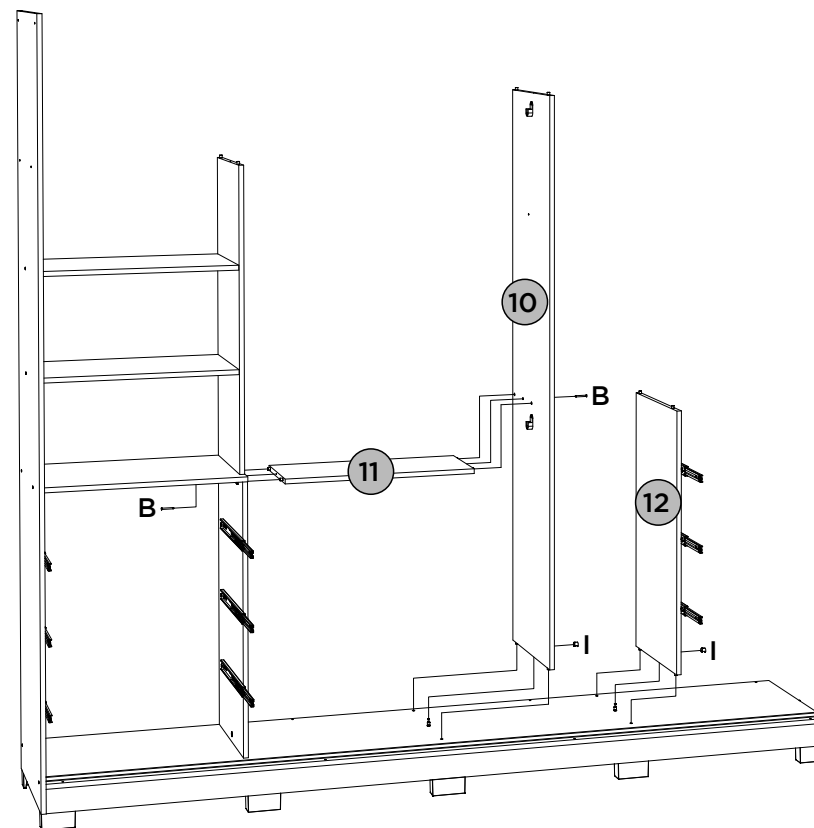
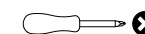

PEÇAS REQUERIDAS

ACESSÓRIOS REQUERIDOS

FERRAMENTAS NECESSÁRIAS

7	TAMPO DAS GAVETAS	x1
8	DIVISÃO SUPERIOR ESQUERDA	x1
9	PRATELEIRA	x2

B		07
F		02
P		01

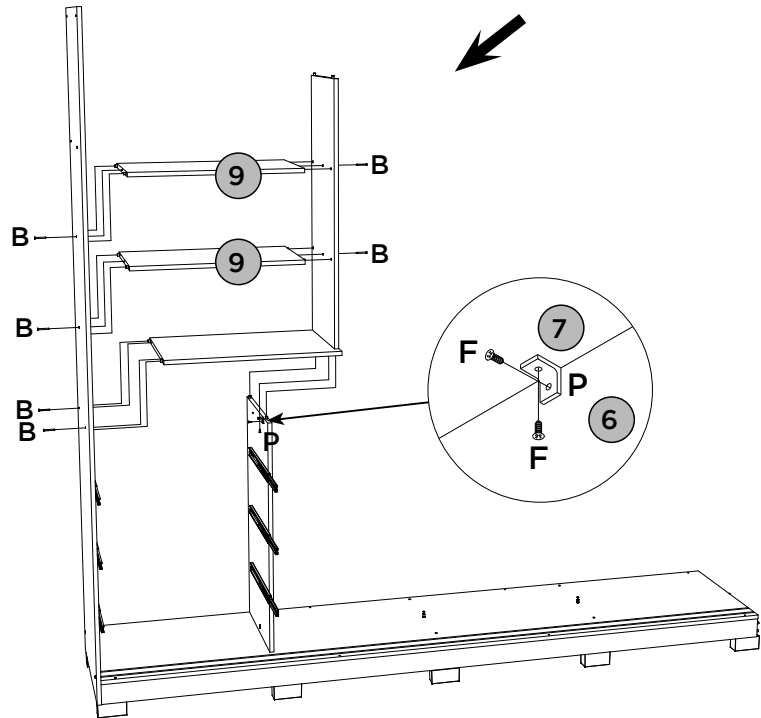
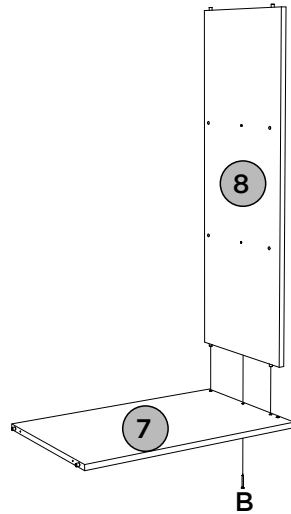
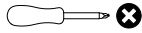

PEÇAS REQUERIDAS

ACESSÓRIOS REQUERIDOS

FERRAMENTAS NECESSÁRIAS

27	PAINEL INFERIOR SUPERIOR	x4
28	PAINEL MENOR	x12
29	PAINEL MAIOR	x2
30	MOLDURA PORTA	x4

C		06
D		32
F		64
O		32

T		01
R		02

Para porta (30): fazer furação passante para puxador (R)

Para la puerta (30): hacer agujeros pasantes para la manija (R)

For door (30): make through holes for handle (R)

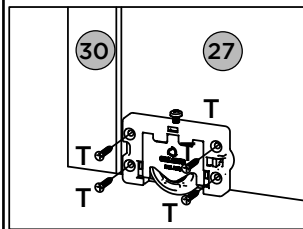
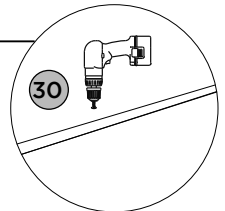

Deixar a Roldana (T) encostada na Moldura (30)

Deje la polea (T) contra el marco (30)

Leave the pulley (T) against the frame (30)

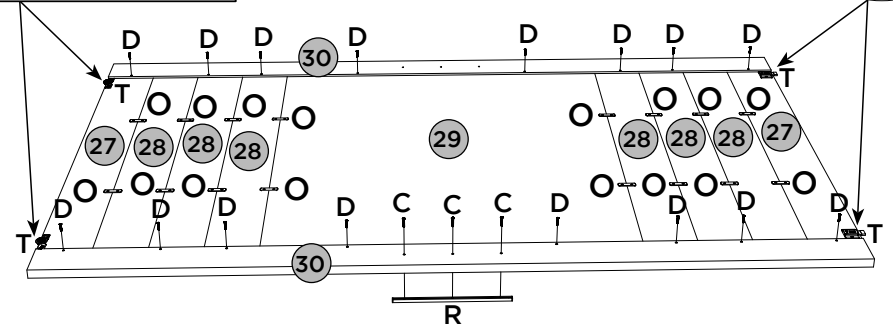
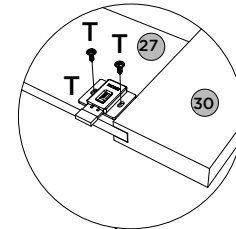
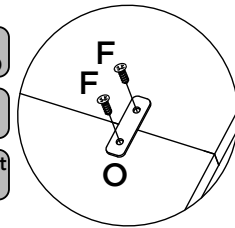

PEÇAS REQUERIDAS

ACESSÓRIOS REQUERIDOS

FERRAMENTAS NECESSÁRIAS

24	LADO DE GAVETA	x12
----	----------------	-----

G		48
X		

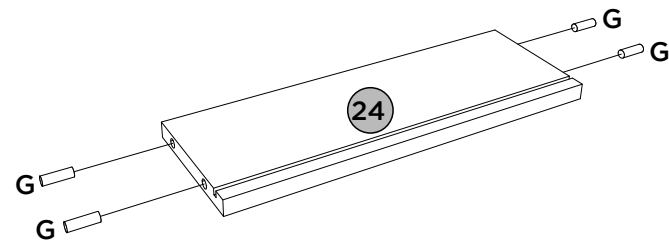

! O974-64 KIT ESPELHO 1028x500x3 COM 2 UNIDADES

Esse Kit Espelho é opcional e é vendido separadamente.

Este juego de espejos es opcional y se vende por separado.

This Mirror Kit is optional and sold separately.

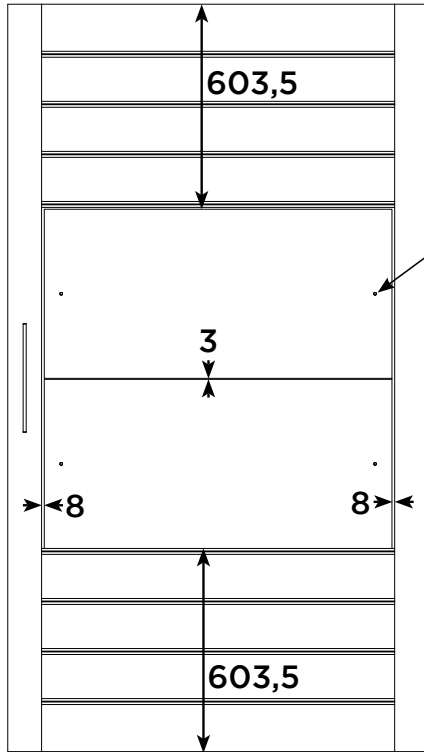

Fixar o Espelho com a Bucha e o Parafuso, que acompanha o kit.

Arreglar el espejo con el Casquillo y Tornillo, que viene con el kit.

Attach the Mirror with the Bushing and Screw, which accompanies the kit.

Utilizar a parafusadeira com o torque 3.

Utilice el destornillador con torque 3.

Use the screwdriver with torque 3.

Medidas em mm

Medidas en mm

Measurements in mm

MONTAGEM 1 | MONTAJE 1 | ASSEMBLY 1

PEÇAS REQUERIDAS

1	RODAPÉ FRONTAL	x1
2	TRAVESSA DO RODAPÉ	x3
3	RODAPÉ TRASEIRO	x1

ACESSÓRIOS REQUERIDOS

F		06
---	--	----

FERRAMENTAS NECESSÁRIAS

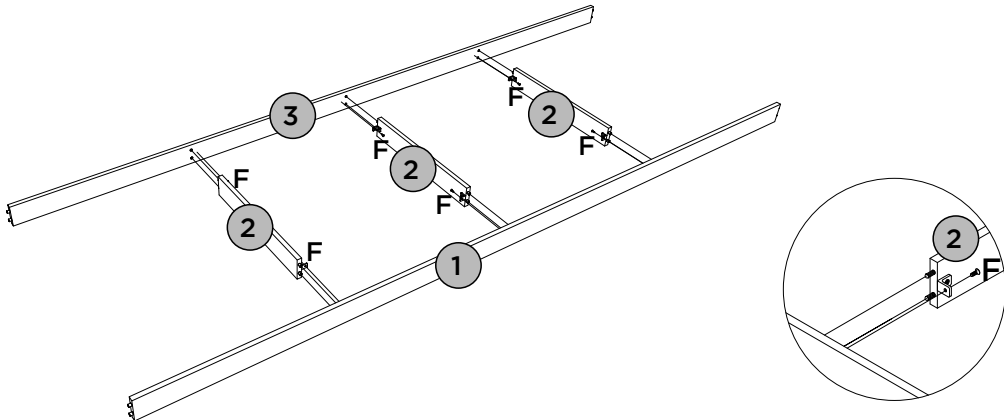
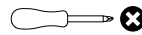

MONTAGEM 2 | MONTAJE 2 | ASSEMBLY 2

PEÇAS REQUERIDAS

4	BASE	x1
5	LATERAL ESQUERDA	x1
6	DIVISÃO INFERIOR ESQUERDA	x1

ACESSÓRIOS REQUERIDOS

A		02
B		08
F		27
I		01
Q		09

FERRAMENTAS NECESSÁRIAS

