

# MANUAL DE MONTAGEM

Assembly instructions / Instrucciones de armado

## KIT PORTUGAL

Kit Portugal  
Kit Portugal

Código 1230 | Revisão 03

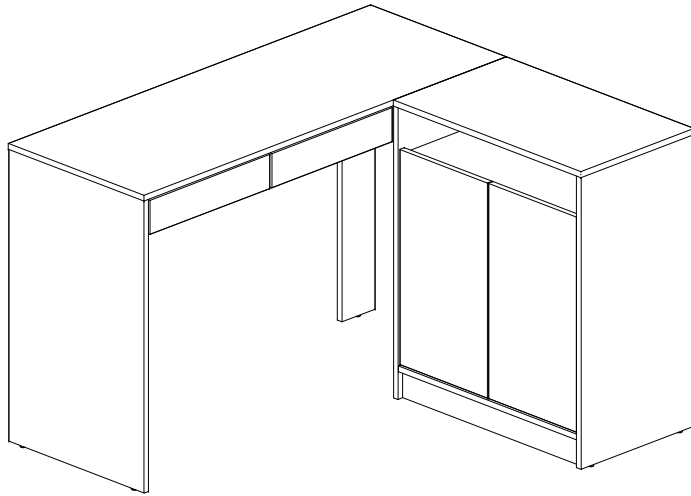

### PESO MÁXIMO SUPORTADO PELAS PEÇAS, SENDO ESTE DISTRIBUÍDO UNIFORMEMENTE.

Maximum weight supported by parts, being this evenly distributed.  
Peso máximo soportado por las partes, siendo esta distribuido uniformemente.

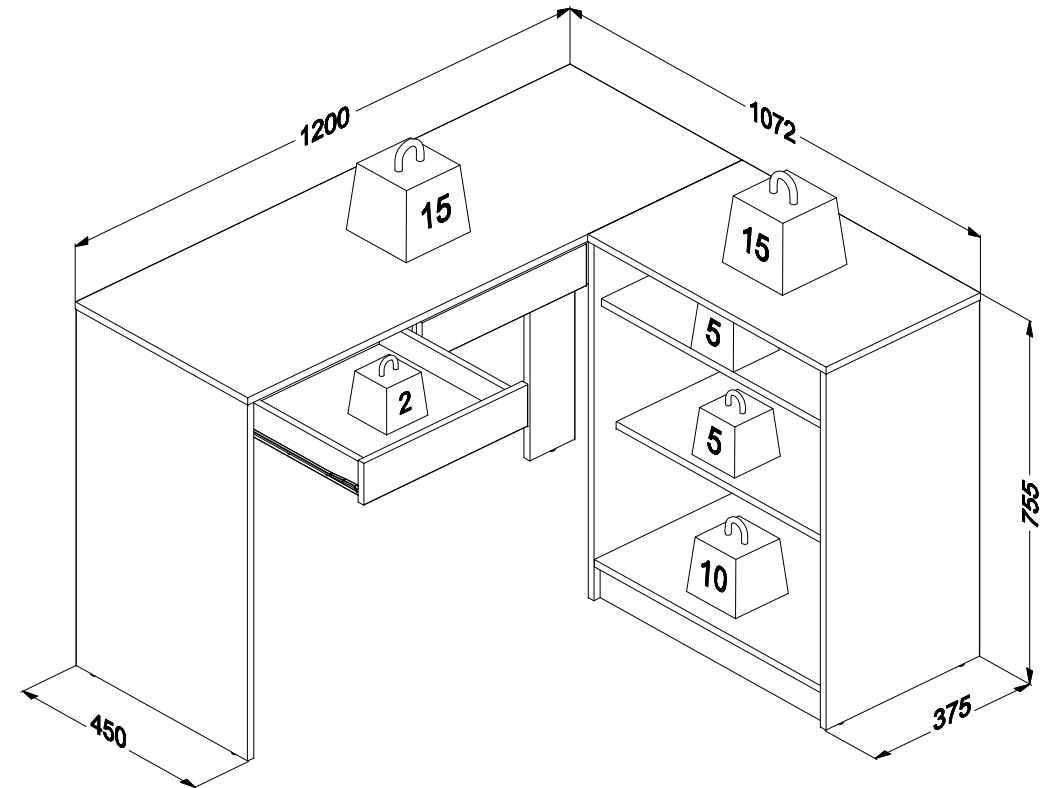

### Você vai precisar de/ You will need / Usted necesitará

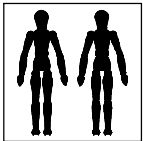

2 Pessoas  
2 People  
2 Personas

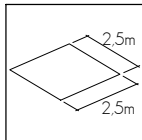

Espaço recomendado para montagem  
Recommended space for assemble  
Espacio recomendado para el armado

Ferramentas não inclusas  
Tools not included / Herramientas no incluidas

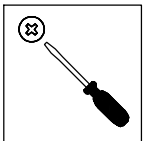

Chave Philips  
Screwdriver  
Destornillador cruz

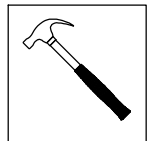

Martelo  
Hammer  
Martillo











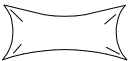

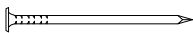
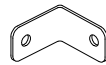
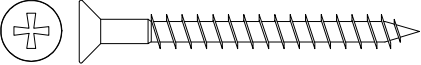

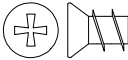
\* PESO EM KG/ Weight in Kg/ Peso en Kg  
DIMENSÕES EM MM/ Dimensions in mm/ Dimensiones en mm

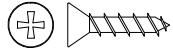
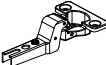
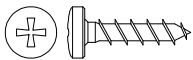
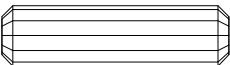
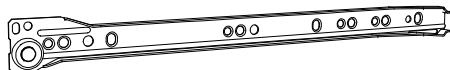
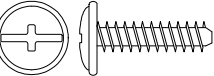
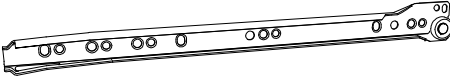
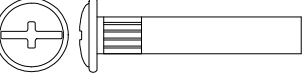
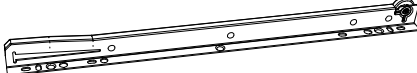
**IDENTIFICAÇÃO DOS ACESSÓRIOS/ IDENTIFICATION OF ACCESSORIES/ IDENTIFICACIÓN DE ACCESORIOS**

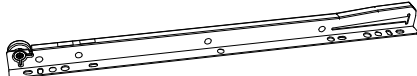
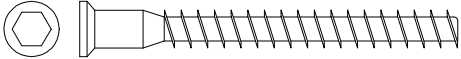
**NOTAS:** A separação dos acessórios antes de iniciar a montagem facilitará a mesma. Os parafusos e cavilhas estão na escala real. Em caso de dúvida na identificação, coloque o acessório sobre a imagem.

**NOTES:** The separation of the accessories before you start the assembly will facilitate the same. The screws and dowels are in real scale. In case of doubts about the identification, place the accessory on the image.

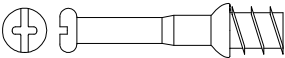
**NOTAS:** La separación de los accesorios antes de comenzar el armado facilitará el mismo. Los tornillos y taquetes son en escala real. En caso de dudas sobre la identificación, coloque el accesorio en la imagen.

A1		<b>Cola</b> Glue Pegamento	13g	<b>01</b>	M		<b>Tapa furo adesivo</b> Bore patch adhesive Tapones adhesivo	-	<b>08</b>
A2		<b>Sapata redonda</b> Small plastic foot Pie plástico	14 mm	<b>07</b>	N		<b>Prego</b> Nail Clavo	10 x10	<b>07</b>
A4		<b>Cantoneira de metal</b> Metal bracket Soporte de metal	22x22 mm	<b>08</b>	O		<b>Parafuso chato</b> Flat head screw Tornillo de cabeza plana	4,5x45 mm	<b>04</b>
B5		<b>Cantoneira de metal</b> Metalic angle plates Soporte de metal	46 mm	<b>01</b>	R		<b>Parafuso chato</b> Flat head screw Tornillo de cabeza plana	6,0x08 mm	<b>04</b>
D5		<b>Calço dobradiça</b> Hinge shim Bisagra de calce	-	<b>04</b>	Q		<b>Parafuso chato</b> Flat head screw Tornillo de cabeza plana	3,0x14 mm	<b>12</b>
D6		<b>Dobradiça super alta</b> Metal hinge super high Bisagra alta	26mm	<b>04</b>	S		<b>Parafuso panela</b> Pan head screw Tornillo de pan	3,5x14 mm	<b>36</b>
E		<b>Cavilha</b> Wooden Dowel Pin	8x30 mm	<b>40</b>	V		<b>Corrediça lateral esquerda</b> Metallic slide the left field Corredera lateral izquierda	350 mm	<b>02</b>
E1		<b>Parafuso união "M"</b> Screw union "M" Tornillo de unión "M"	4,0x15 mm	<b>02</b>	W		<b>Corrediça lateral direita</b> Metallic slide the right field Corredera lateral derecha	350 mm	<b>02</b>
E2		<b>Parafuso união "F"</b> Screw union "F" Tornillo de unión "F"	30 mm	<b>02</b>	X		<b>Corrediça gaveta esquerda</b> Drawer slide left Corredera izquierda cajón	350 mm	<b>02</b>
E3		<b>Suporte de prateleira</b> Shelf bracket Soporte de repisa	8x7 mm	<b>04</b>	Y		<b>Corrediça gaveta direita</b> Drawer slide right Corredera derecha cajón	350 mm	<b>02</b>
G		<b>Parafuso estrutural</b> Structural screw Tornillo estructural	5,0x50 mm	<b>16</b>	Z		<b>Tapa furo plástico</b> Plastic hole plugs Tapones plásticos	8 mm	<b>02</b>
H		<b>Chave allen</b> Allen key Llave Allen	-	<b>01</b>					
I		<b>Tampa parafuso estrutural</b> Structural screw cover Tapa tornillo estructural	-	<b>12</b>					
J		<b>Haste minifix simples</b> Simple minifix screw Tornillo minifix simple	-	<b>12</b>					
L		<b>Tambor minifix</b> Drum lock Tambor minifix	12 mm	<b>12</b>					

IDENTIFICAÇÃO DAS PEÇAS/ PARTS IDENTIFICATION/ IDENTIFICACIÓN DE LAS PIEZAS

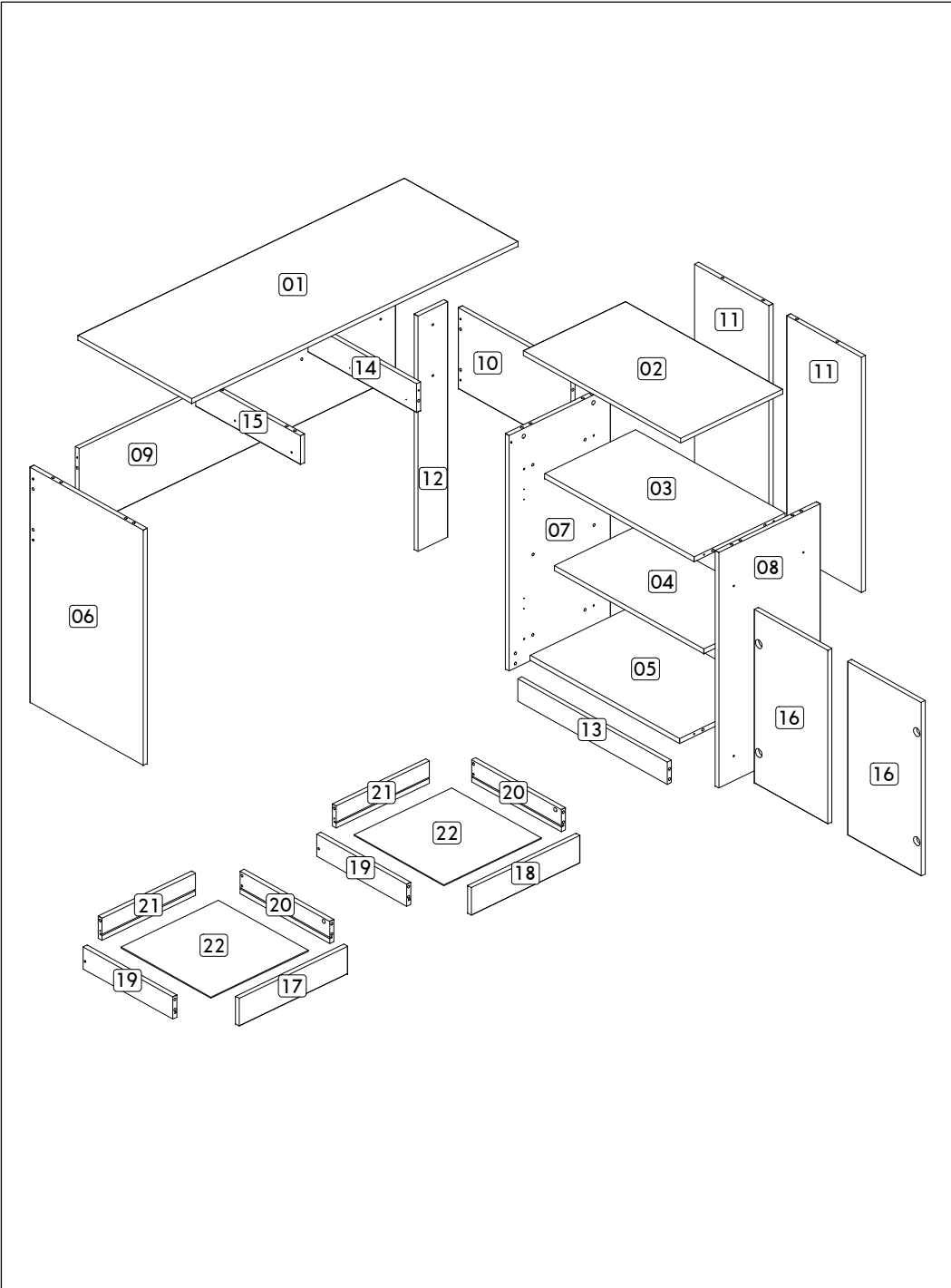

Nº	DESCRIÇÃO - DESCRIPTION - DESCRIPCIÓN	MEDIDAS-MEASURES - MEDIDAS (mm)	QTD.
01	<b>Base superior maior</b> - Bigger top base - Base superior mayor	1200 x 450 x 15	01
02	<b>Base superior menor</b> - Smaller top base - Base superior menor	622 x 375 x 15	01
03	<b>Base intermediária armário</b> - Intermediate base cabinet - Base intermedia armario	590 x 335 x 15	01
04	<b>Prateleira</b> - Shelf - Repisa	590 x 299 x 15	01
05	<b>Base inferior</b> - Bottom base - Base inferior	590 x 352 x 15	01
06	<b>Lateral esquerda</b> - Left side - Lateral izquierda	740 x 448 x 15	01
07	<b>Lateral esquerda armário</b> - Left side cabinet - Lateral izquierda armario	740 x 373 x 15	01
08	<b>Lateral direita armário</b> - Right side cabinet - Lateral derecha armario	740 x 373 x 15	01
09	<b>Costa maior</b> - Bigger back - Fondo mayor	1163 x 255 x 15	01
10	<b>Costa menor</b> - Smaller back - Fondo menor	445 x 255 x 15	01
11	<b>Costa armário</b> - Back cabinet - Fondo armario	740 x 295 x 15	02
12	<b>Pé</b> - Foot - Pie	740 x 110 x 15	01
13	<b>Rodapé</b> - Footer - Rodapie	590 x 70 x 15	01
14	<b>Divisória maior gavetas</b> - Bigger partition drawers - Divisoria mayor cajones	429 x 90 x 15	01
15	<b>Divisória menor gavetas</b> - Smaller partition drawers - Divisoria menor cajones	414 x 90 x 15	01
16	<b>Porta</b> - Door - Puerta	546 x 291 x 15	02
17	<b>Frente de gaveta esquerda</b> - Left drawer front - Frente del cajón izquierda	399 x 87 x 15	01
18	<b>Frente de gaveta direita</b> - Right drawer front - Frente del cajón derecha	399 x 87 x 15	01
19	<b>Lateral esquerda de gaveta</b> - Left side of drawer - Lateral izquierda del cajón	355 x 70 x 15	02
20	<b>Lateral direita de gaveta</b> - Right side of drawer - Lateral derecha del cajón	355 x 70 x 15	02
21	<b>Traseiro de gaveta</b> - Rear of drawer - Trasero del cajón	343 x 70 x 15	02
22	<b>Fundo de gaveta</b> - Bottom of drawer - Fondo del cajón	358 x 355 x 03	02

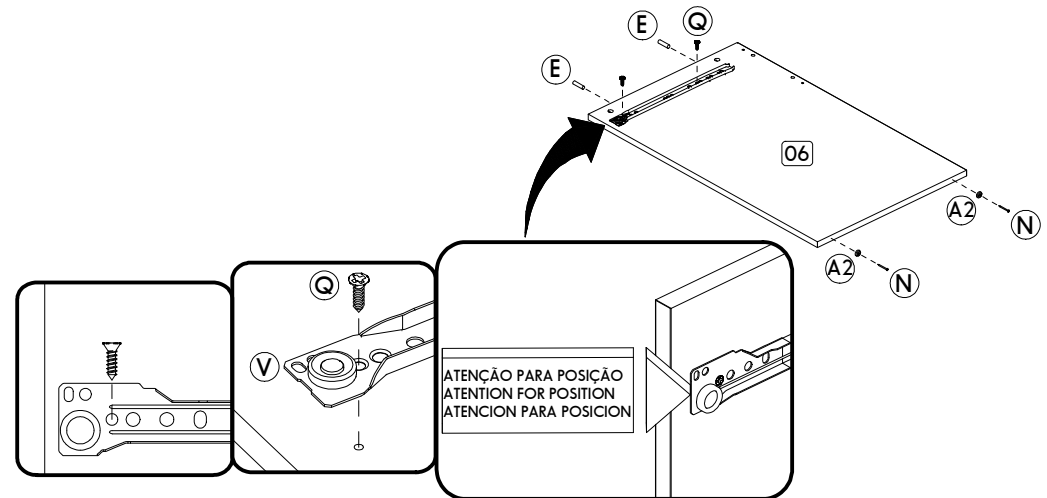
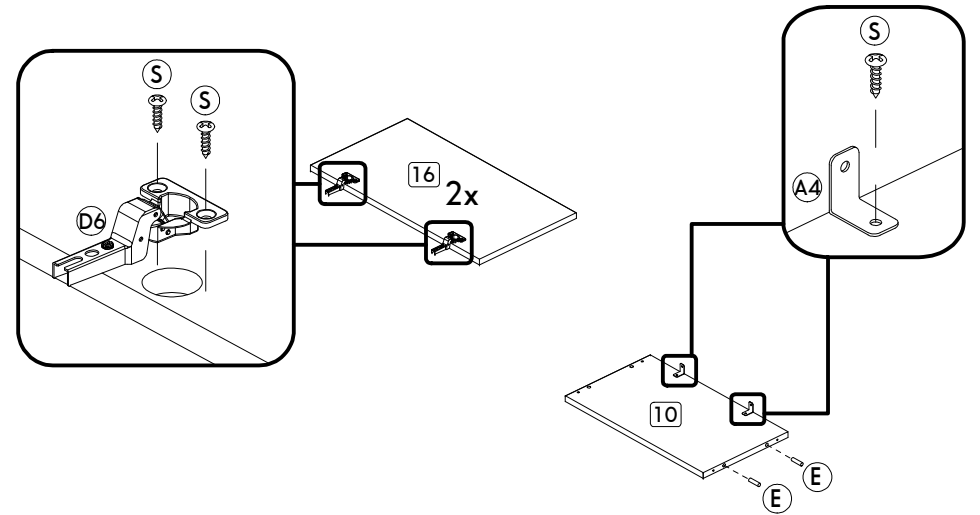
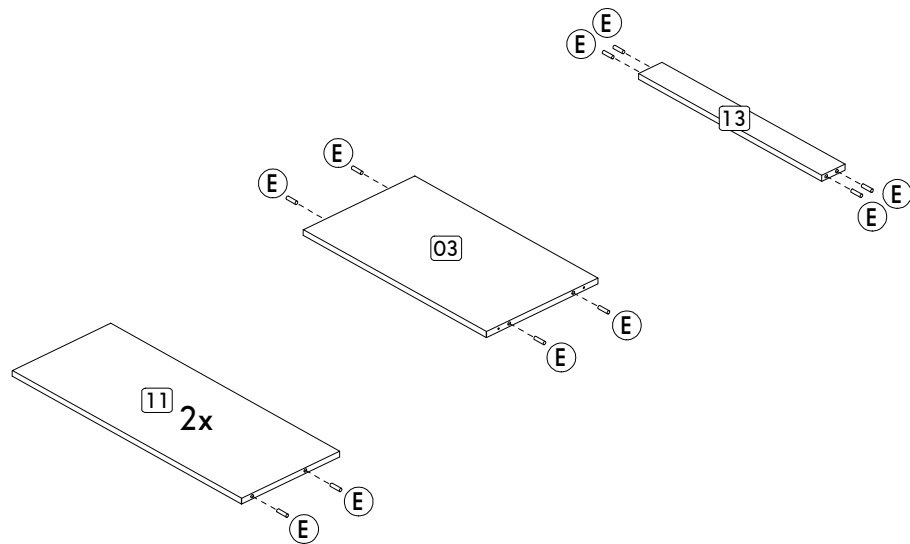
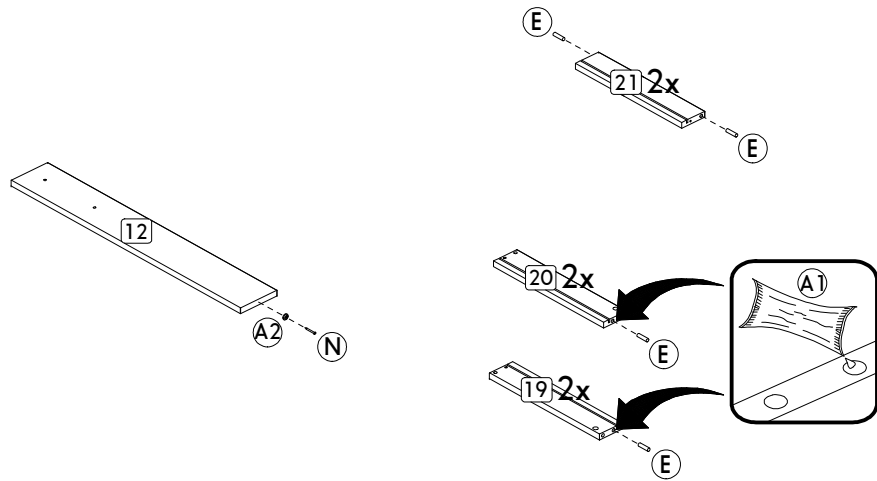

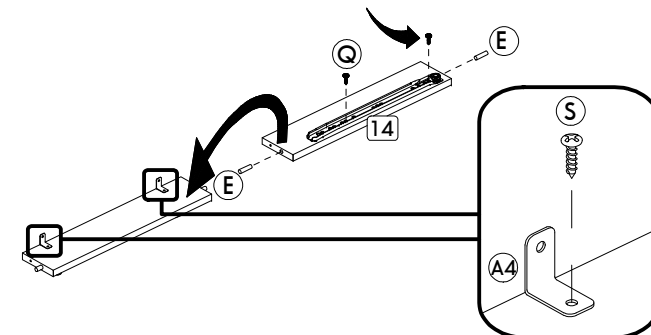
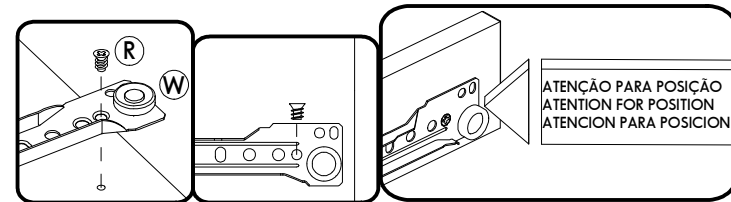
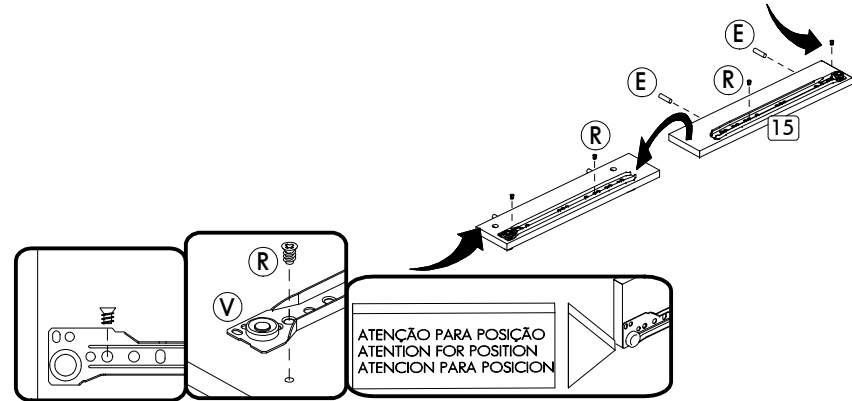
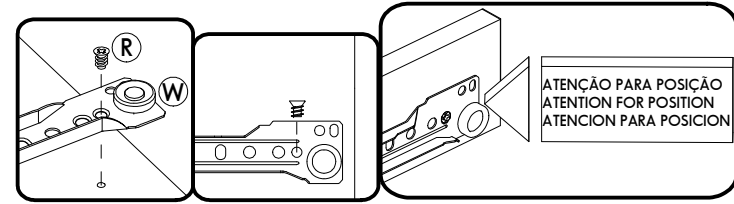
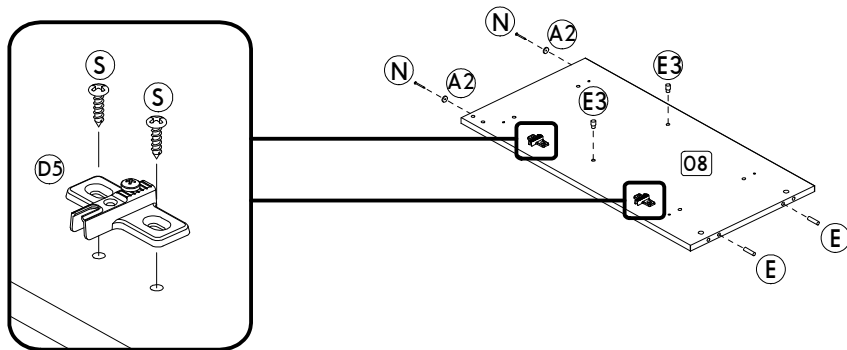
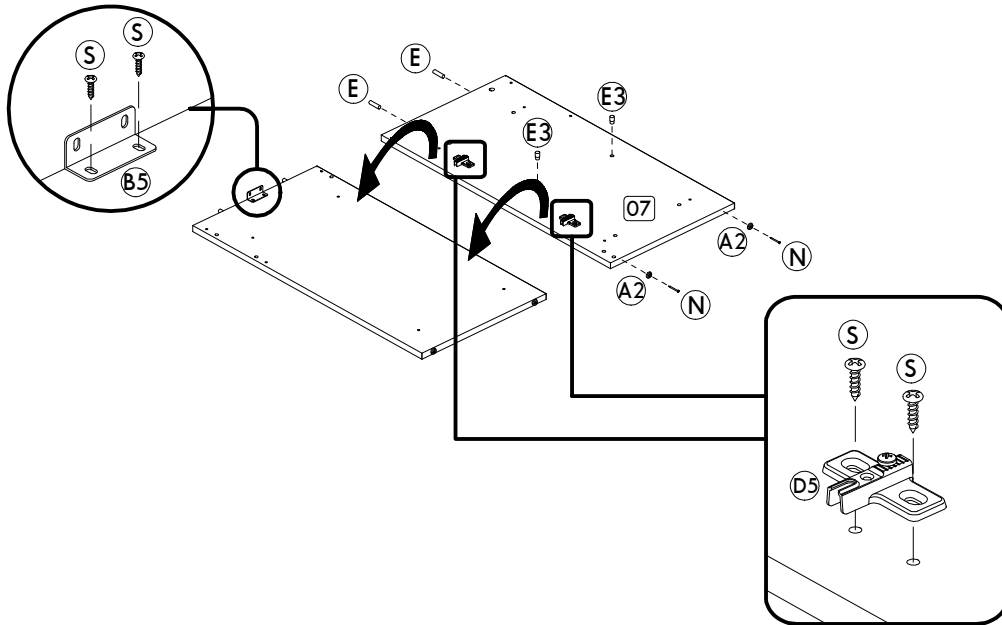

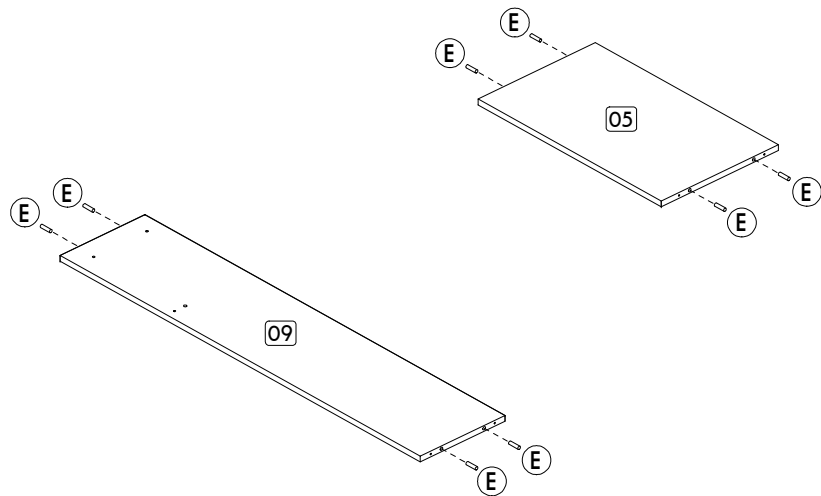
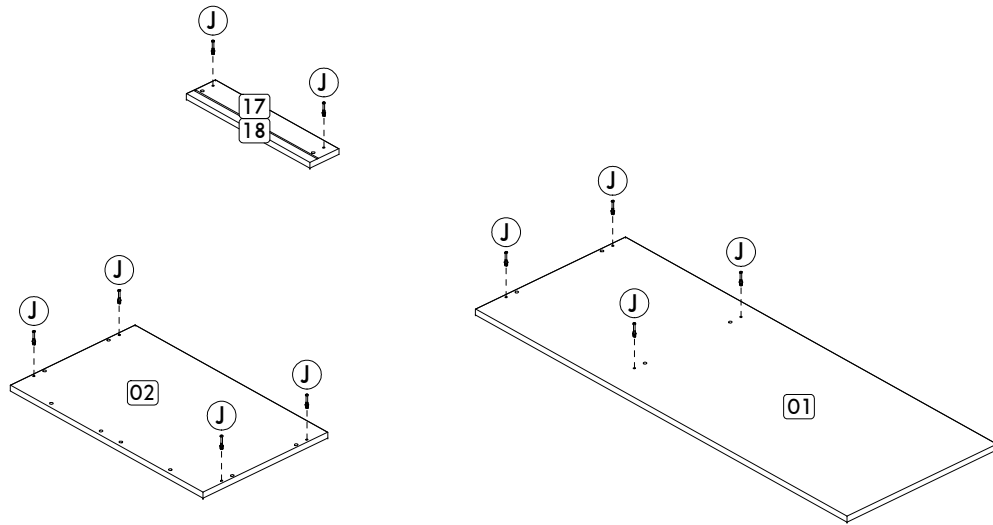

Passo/ Step/ Paso 01

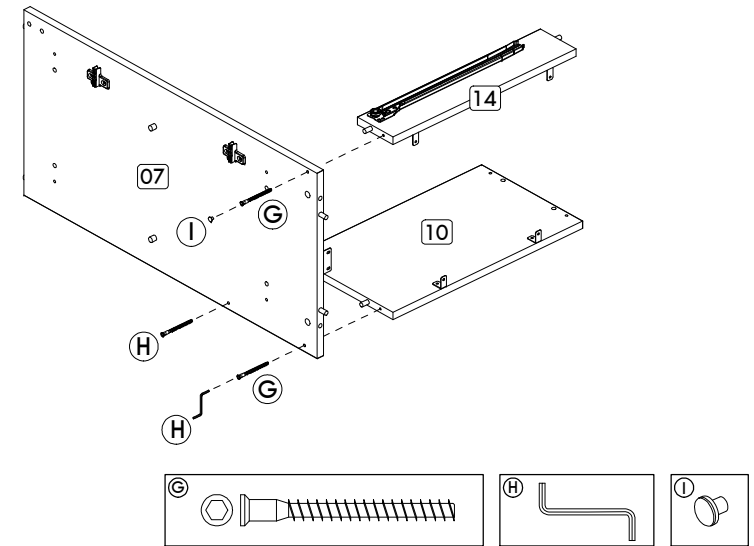

Passo/ Step/ Paso 02

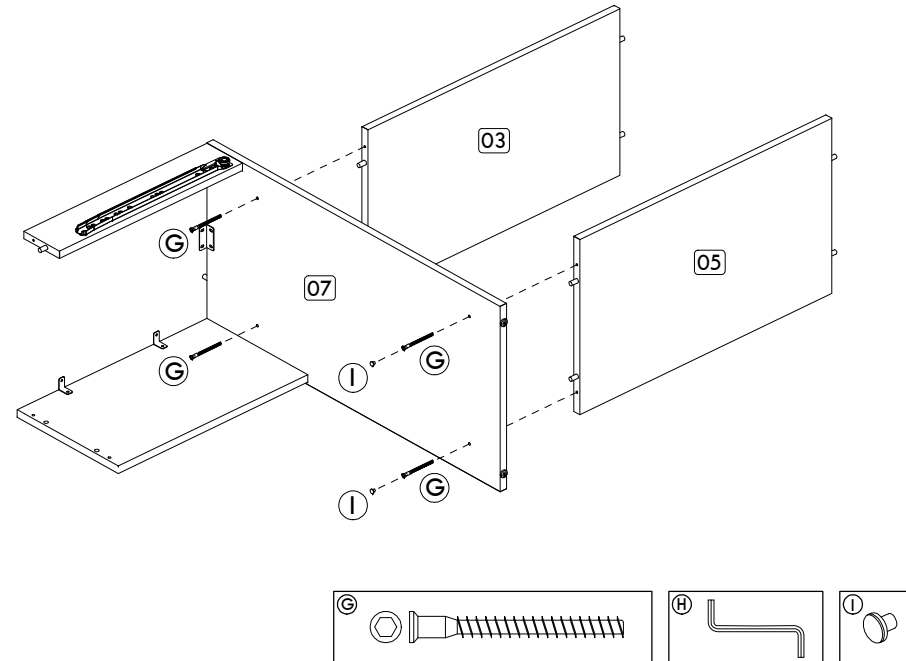

Passo/ Step/ Paso 03

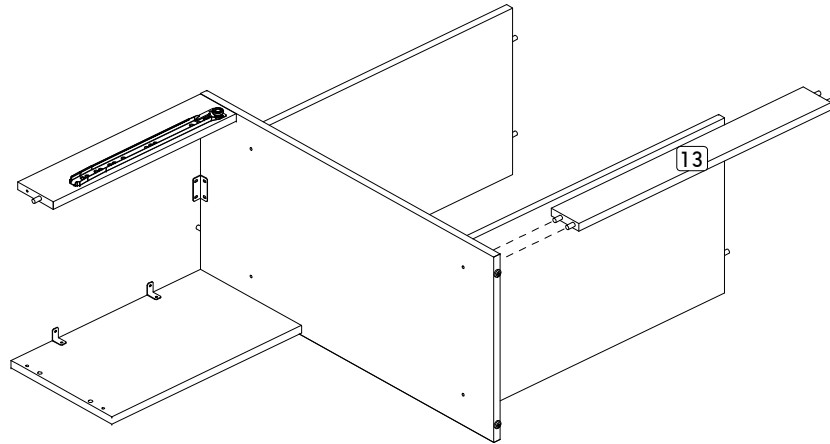

Passo/ Step/ Paso 04

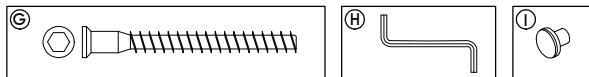
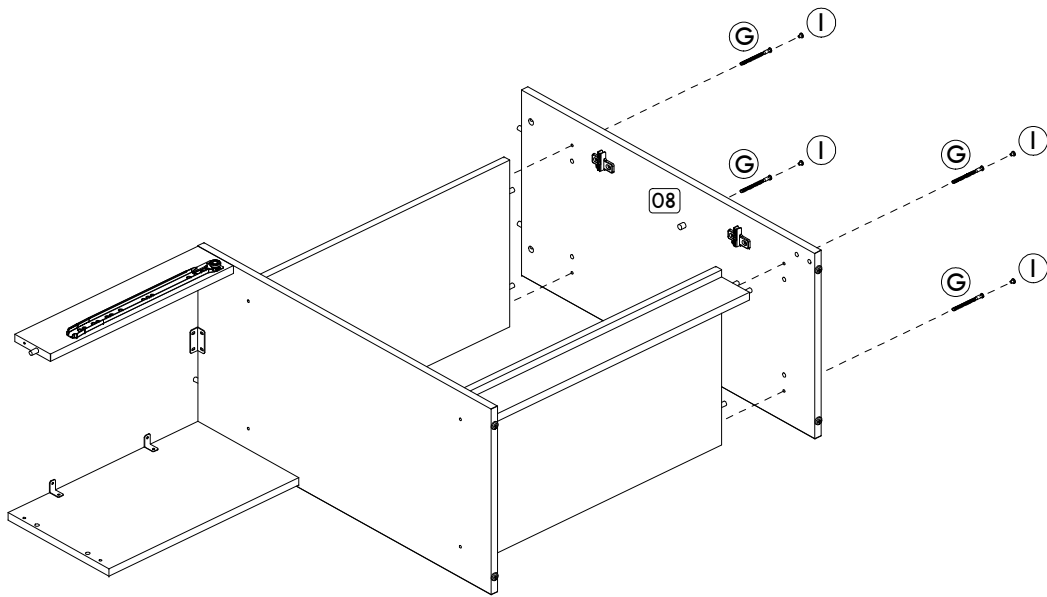

Passo/ Step/ Paso 05

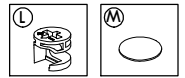
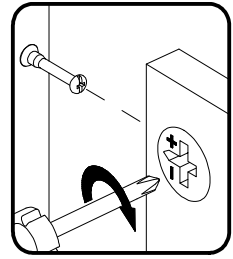
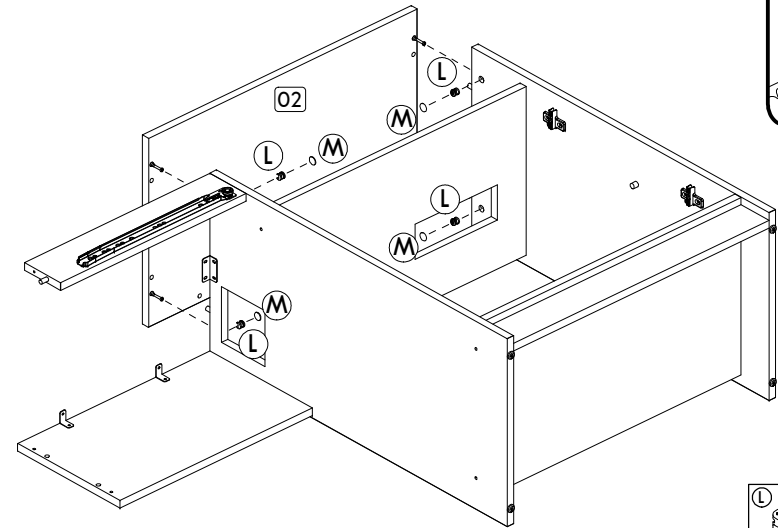

Passo/ Step/ Paso 06

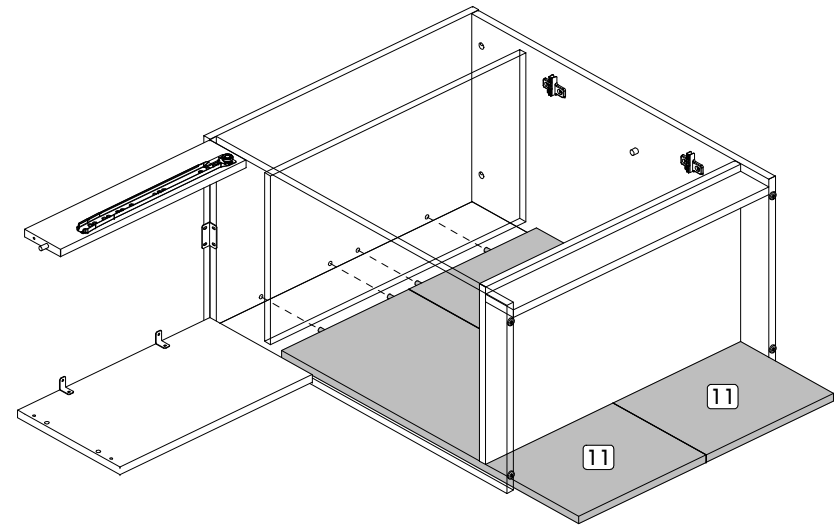

Passo/ Step/ Paso 07

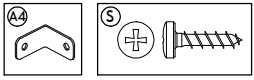
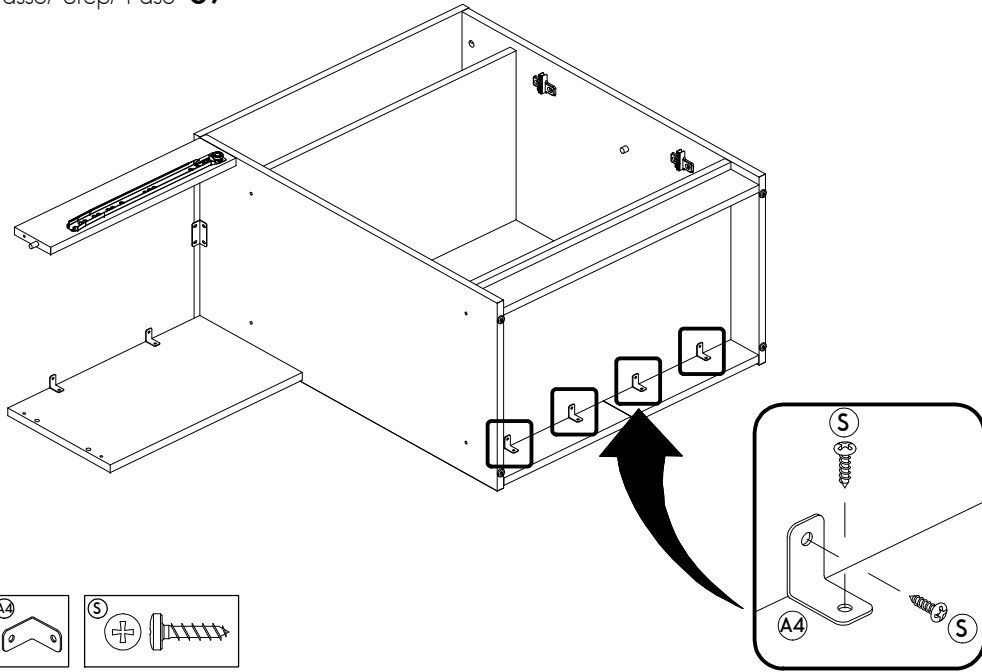

Passo/ Step/ Paso 08

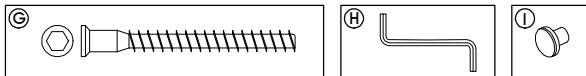
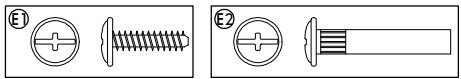
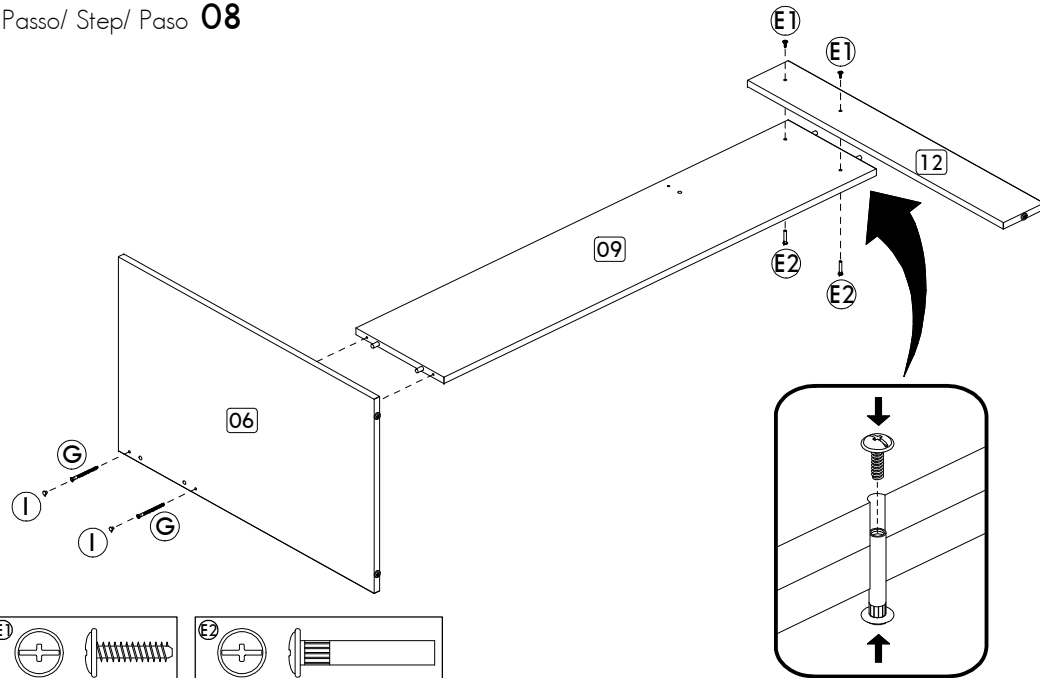

Passo/ Step/ Paso 09

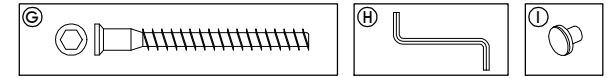
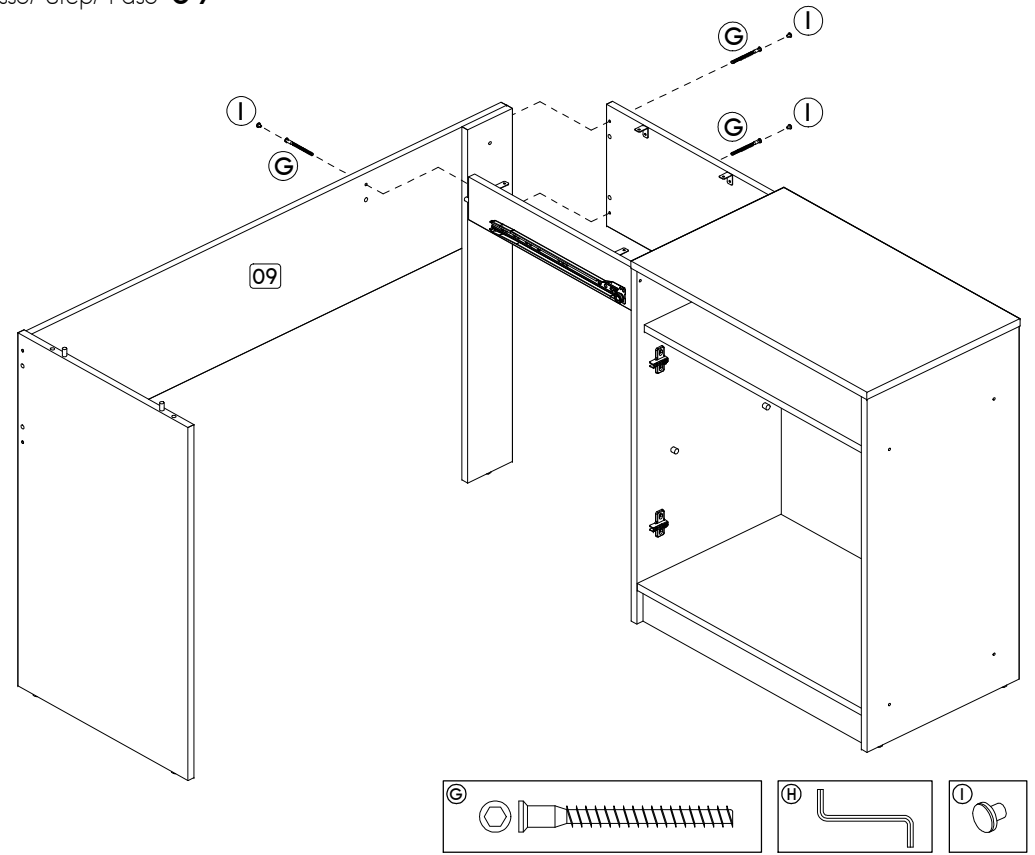

Passo/ Step/ Paso 10

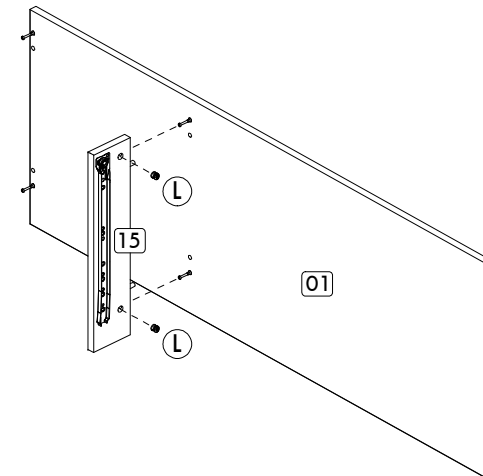



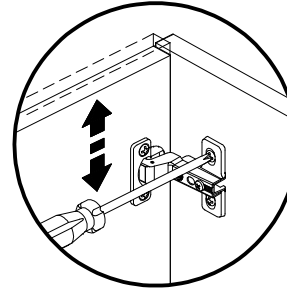
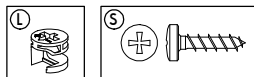
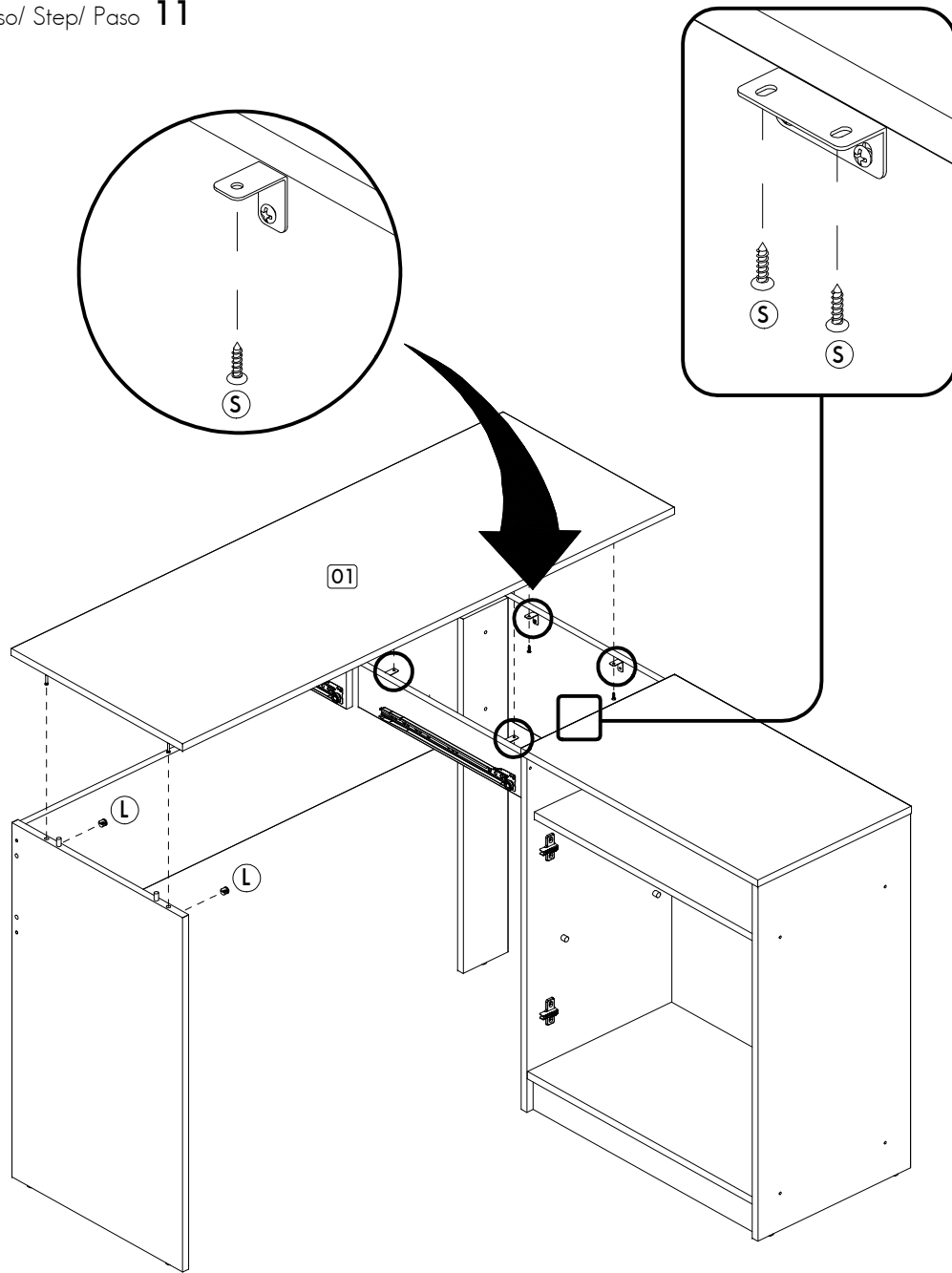

Regulagem Vertical  
Ajuste Vertical  
Vertical Adjustment

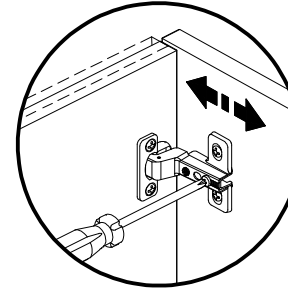

Regulagem Profundidade  
Ajuste Profundidad  
Depth Adjustment

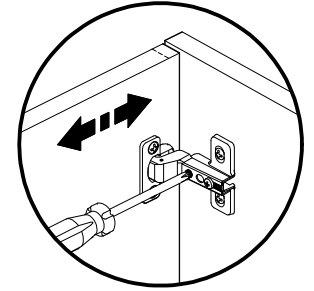

Regulagem Horizontal  
Ajuste Horizontal  
Horizontal Adjustment

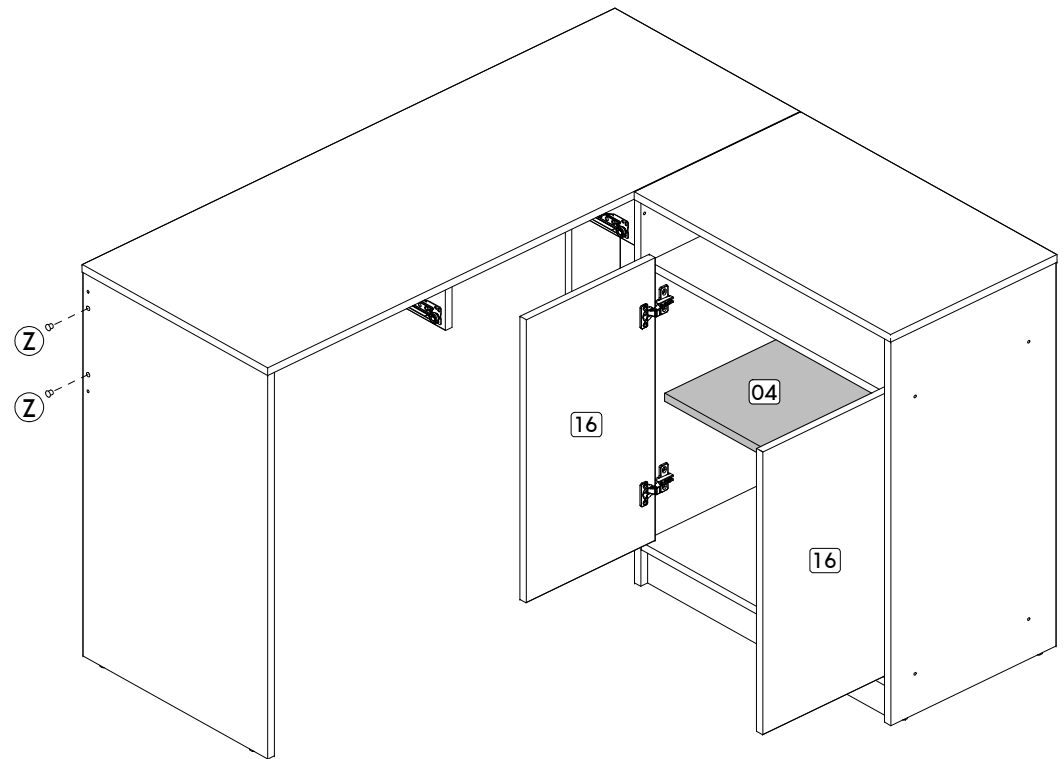

Passo/ Step/ Paso 13

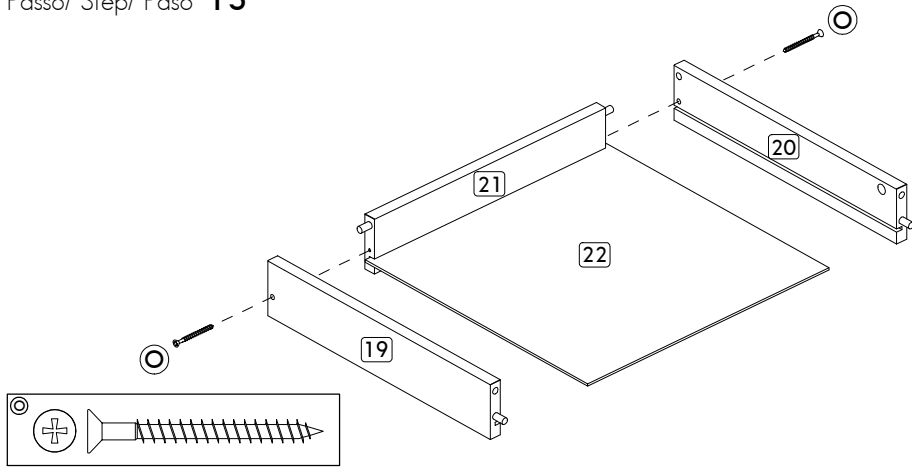

Passo/ Step/ Paso 14

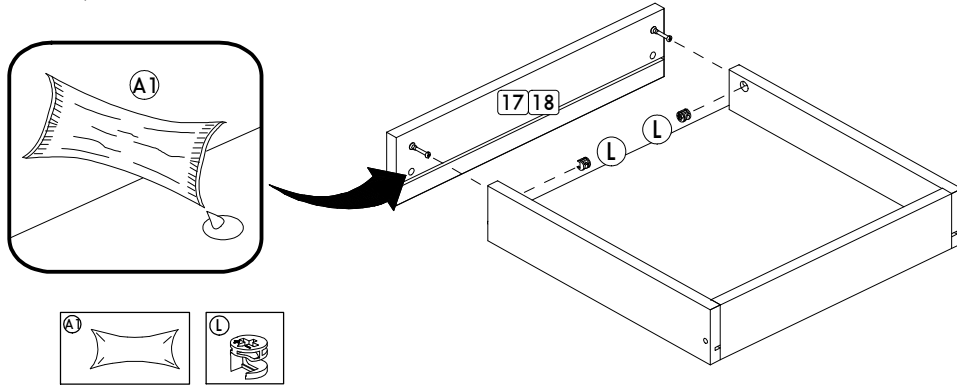

Passo/ Step/ Paso 15

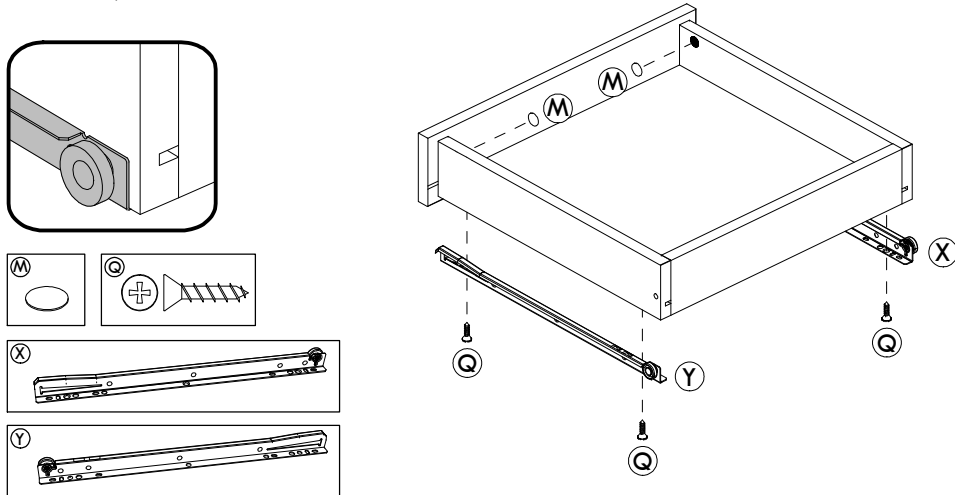

Passo/ Step/ Paso 16

