

YOU WILL NEED

TU AURAS BESOIN DE | NECESITARÁ | VOCÊ VAI PRECISAR

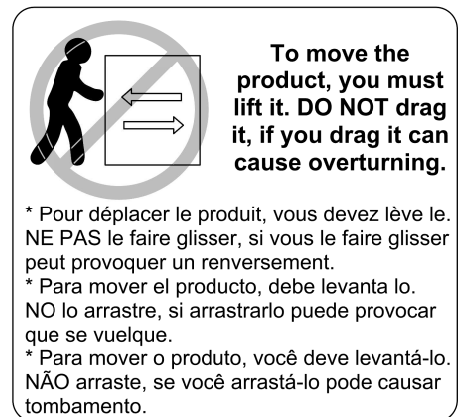
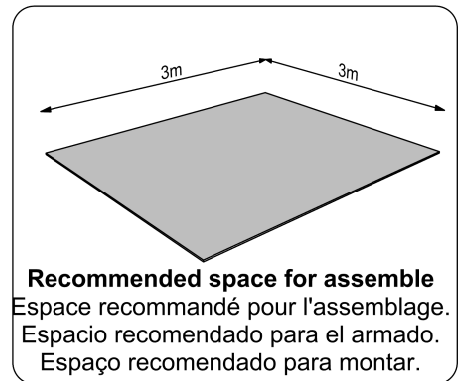
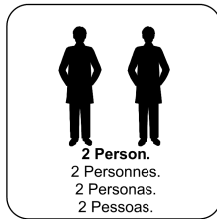
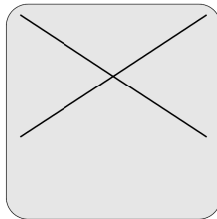
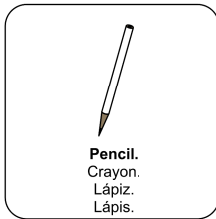
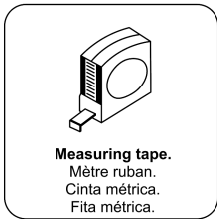
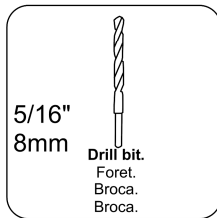
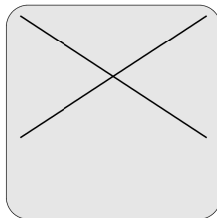
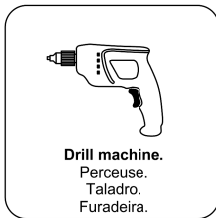
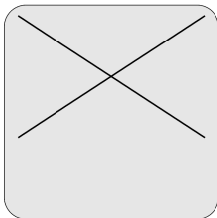
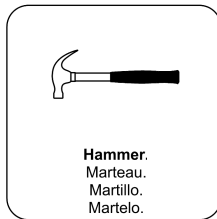
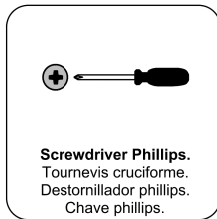
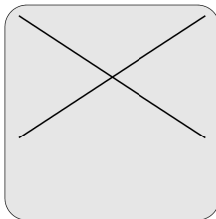
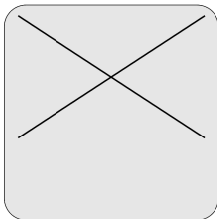

Tools not included

Outils non inclus | Herramientas no incluidas | Ferramentas não inclusas

ACCESSORIES IDENTIFICATION

IDENTIFICATION DES ACCESSOIRES | IDENTIFICACIÓN DE ACCESORIOS
IDENTIFICAÇÃO DOS ACESSÓRIOS

A  Qty./Qtd. **4**
Wooden dowel / Chevilles en bois / Taquete / Cavilha

AL  Qty./Qtd. **4**
Flanged head screw / Vis à tête bride / Tornillo de cabeza flangeada / Parafuso Flangeado

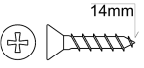
AR  Qty./Qtd. **8**
Flat head screw / Vis plate / Tornillo de cabeza plana / Parafuso cabeça chata

AY  Qty./Qtd. **2**
Wire finishing / Passer le fil / Cubierta de cableado / Passa Fios

CD  Qty./Qtd. **46**
Flat head screw / Parafuso chato / Tornillo de cabeza plana

CI  Qty./Qtd. **2**
Pan head screw / Vis à tête bombée / Tornillo de pan / Parafuso Panela

CT  Qty./Qtd. **4**
Metallic bracket / Support métallique / Suporte de metal

P  Qty./Qtd. **20**
Wooden dowel / Chevilles en bois / Taquete / Cavilha

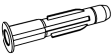
S  Qty./Qtd. **4**
Bushing / Douille expansive / Tapón / Bucha Plástica

T  Qty./Qtd. **4**
Flanged head screw / Vis à tête bride / Tornillo de cabeza flangeada / Parafuso flangeado

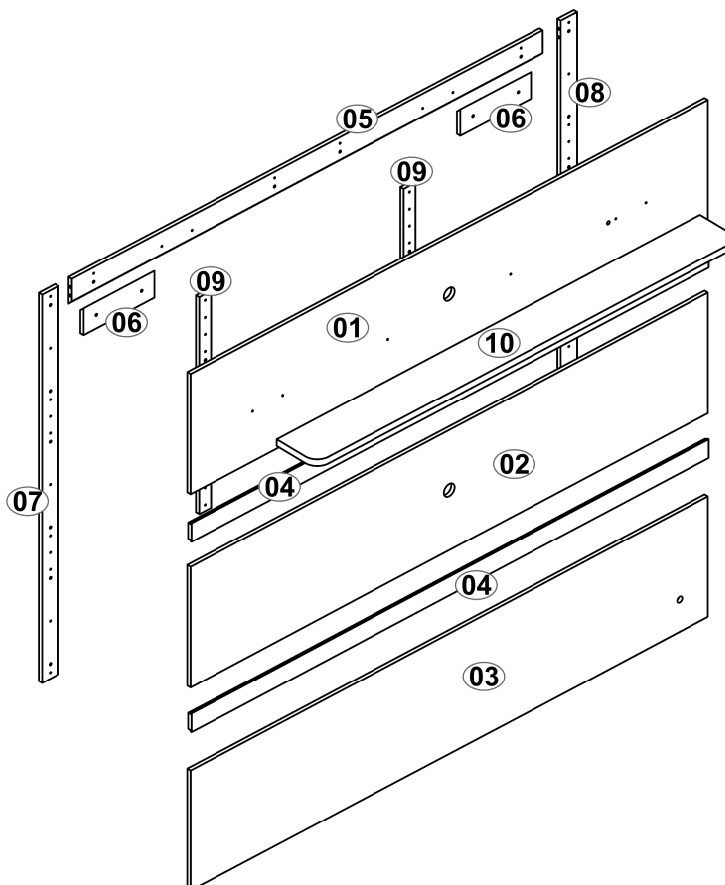

PRE-ASSEMBLY - PRÉ-ASSEMBLAGE - PRE-ARMADO PRÉ-MONTAGEM

01 -

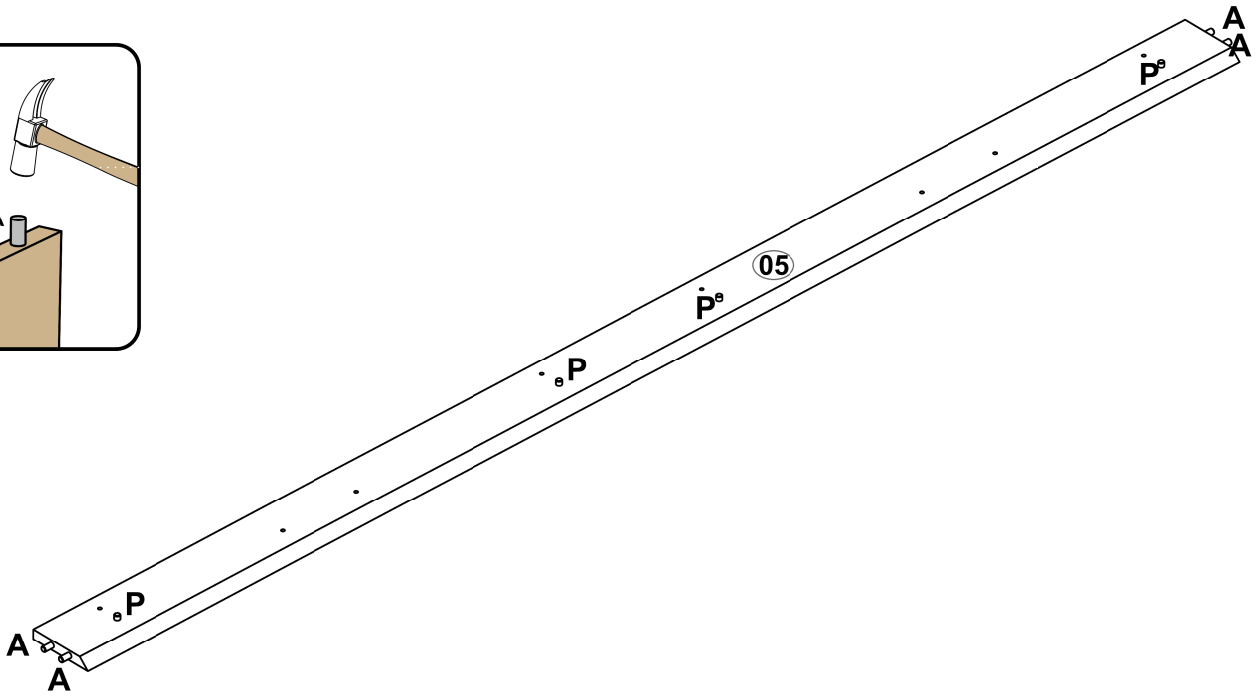
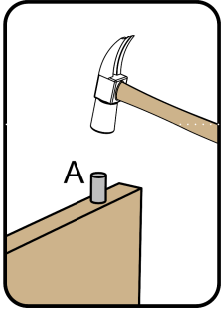

02 -

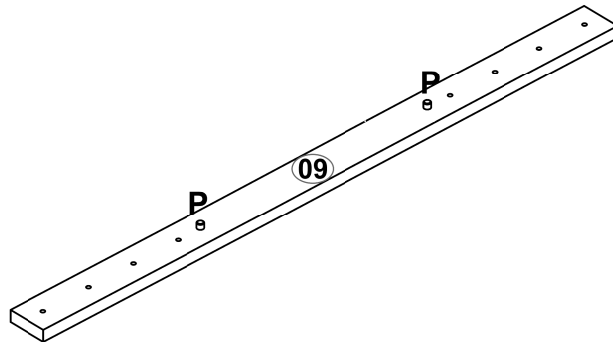

03 -

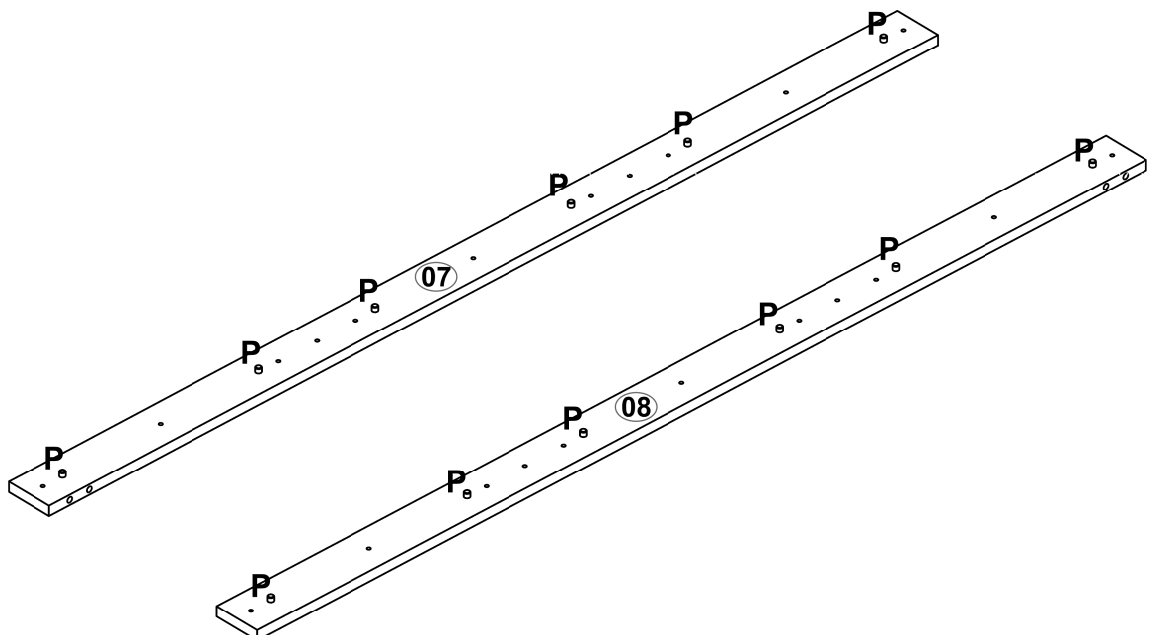

ASSEMBLY - MONTAGE - ARMADO - MONTAGEM

M01 -

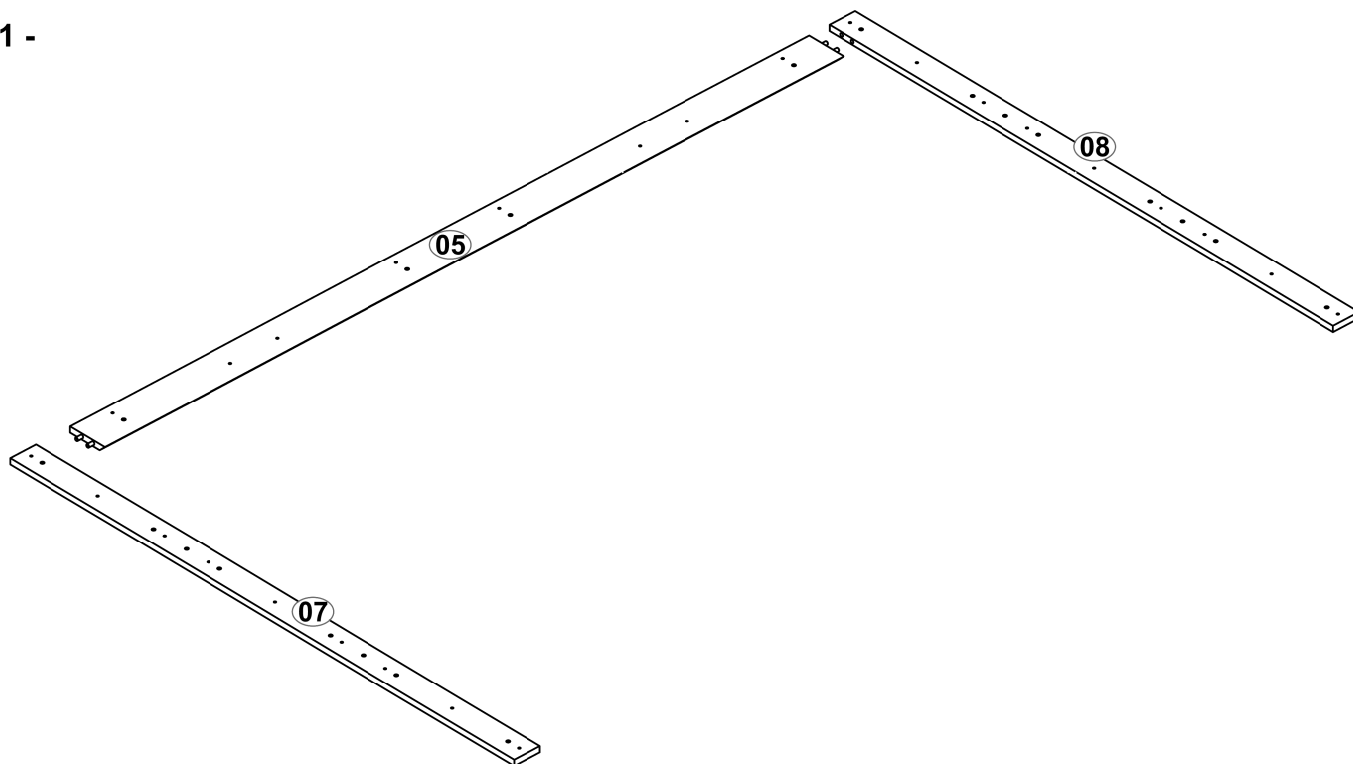

M02 -

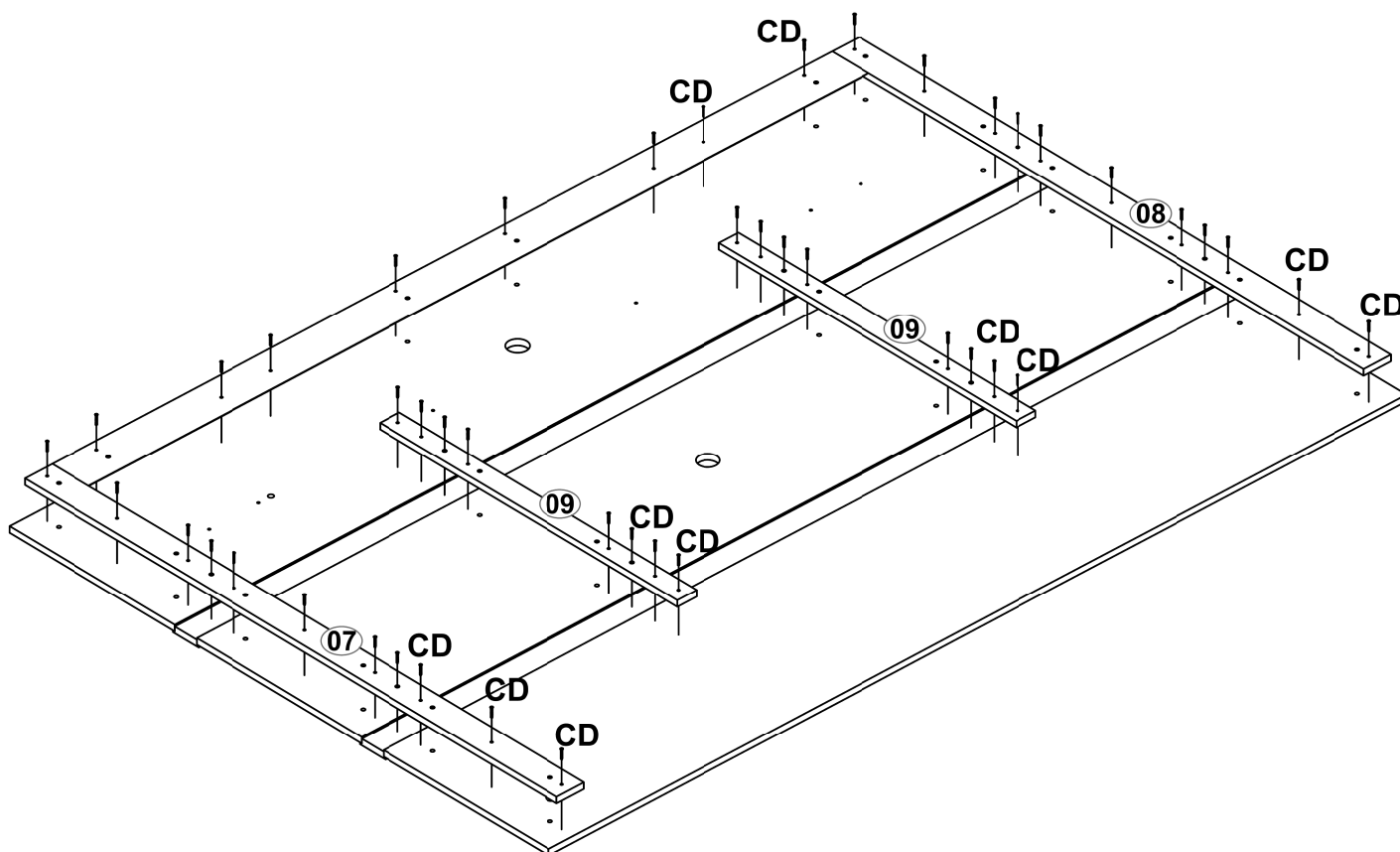

M03 -

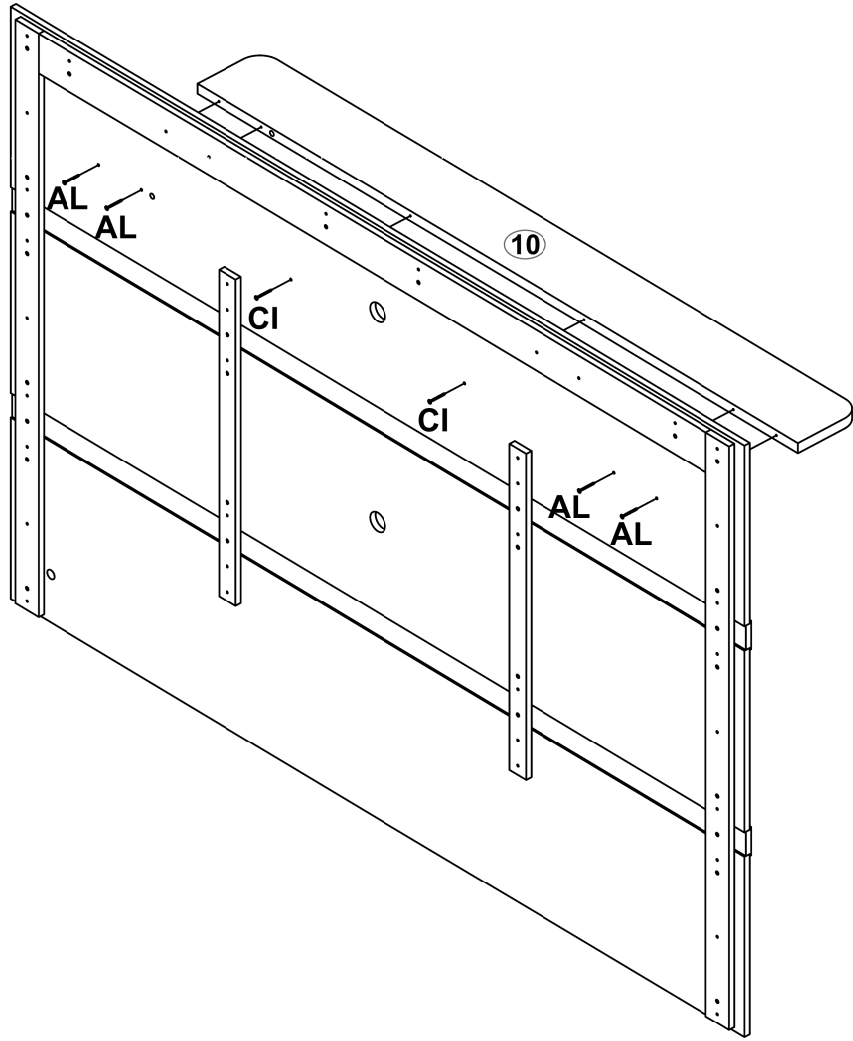

M04 -

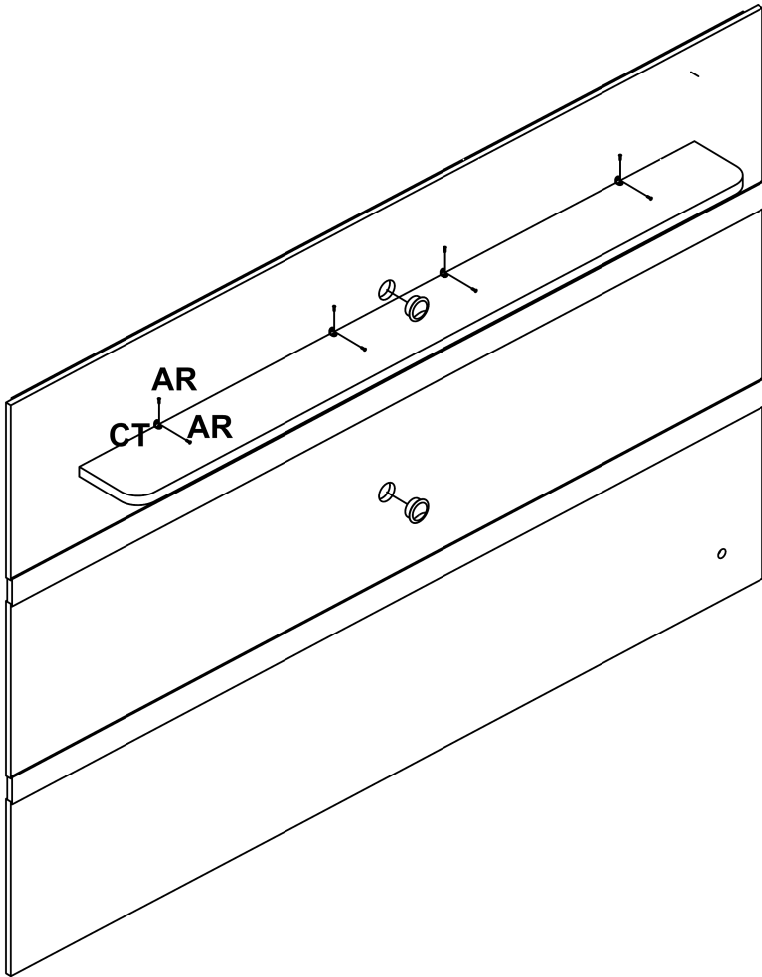

M05 - * Retire a película protetora da fita dupla face e inicie a colagem da fita de led no canal da peça nº 10.

* Após instalar a fita de Led.
Encaixar o perfil de acabamento do Led.

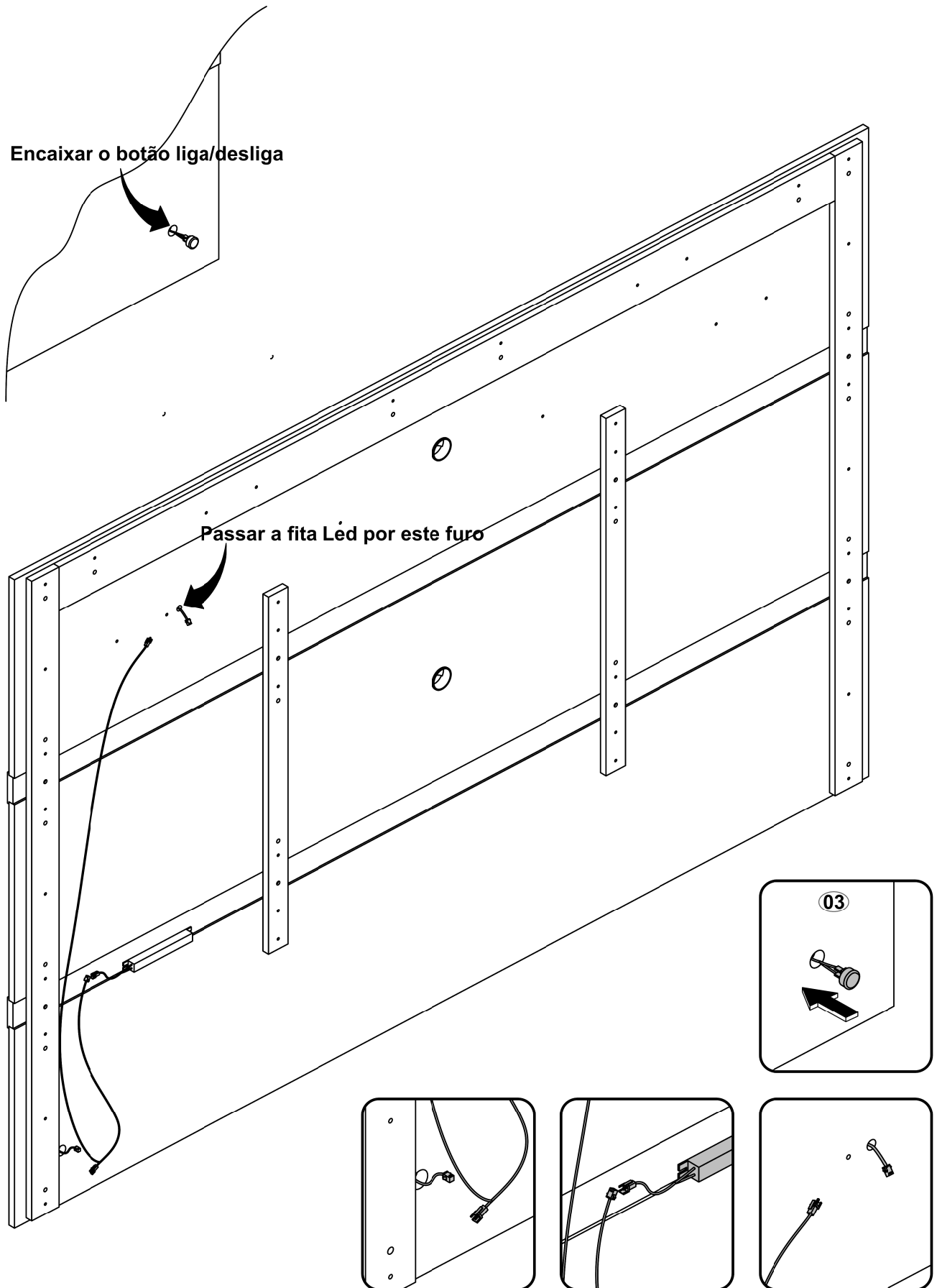

M06 -

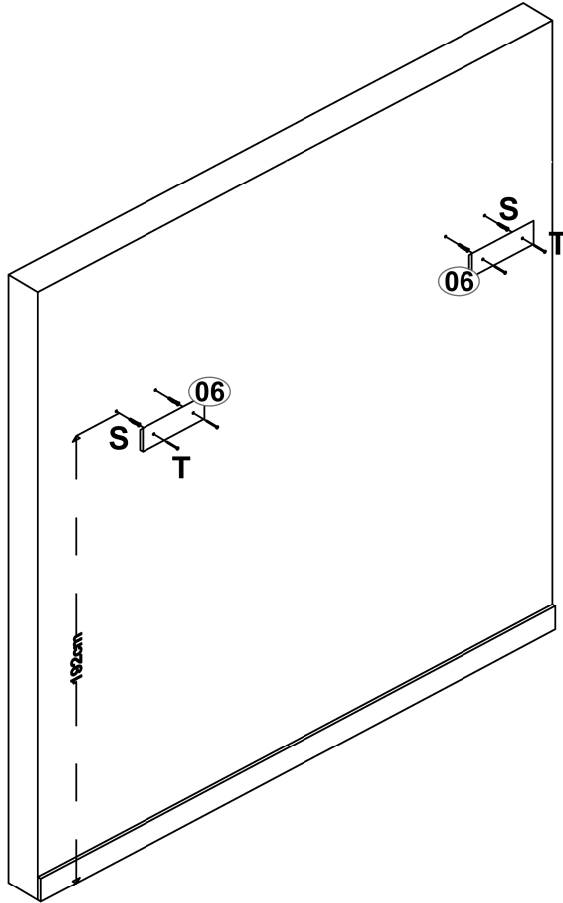
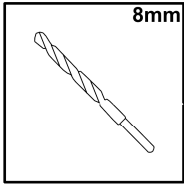
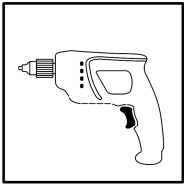

M07 -

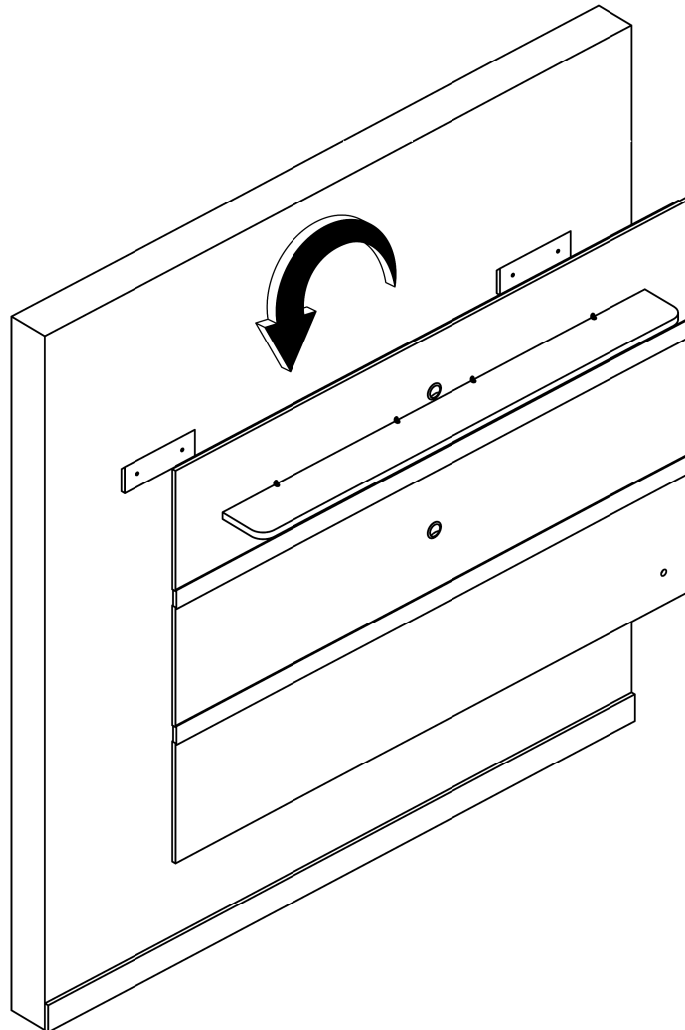

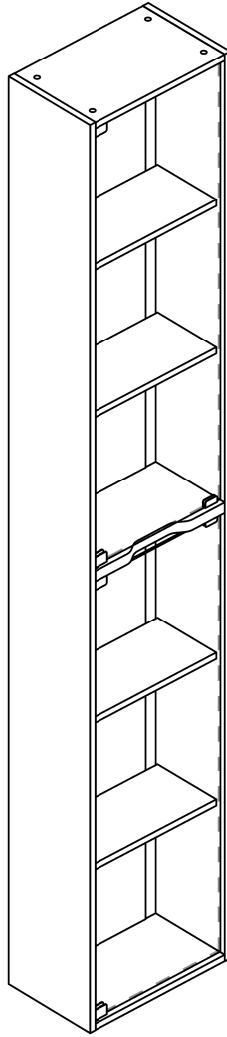

YOU WILL NEED

TU AURAS BESOIN DE | NECESITARÁ | VOCÊ VAI PRECISAR

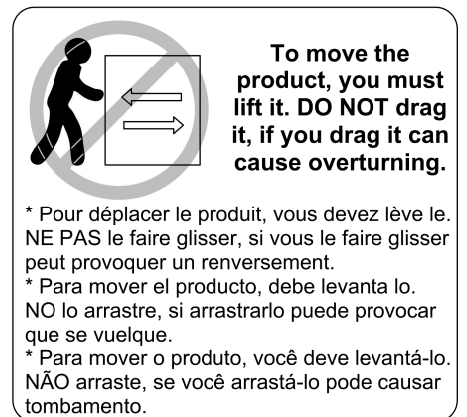
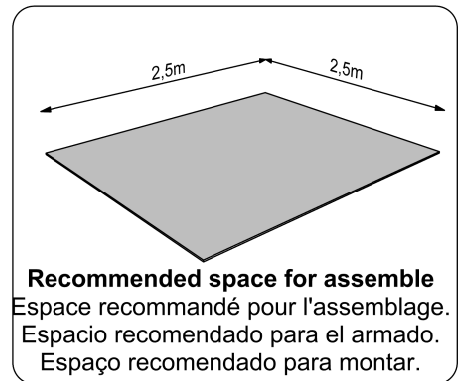
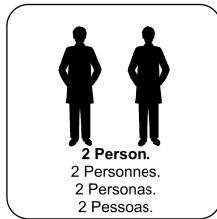
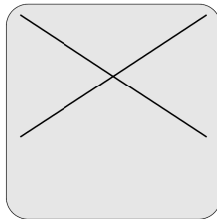
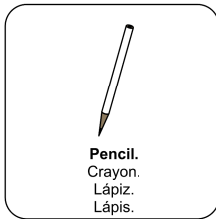
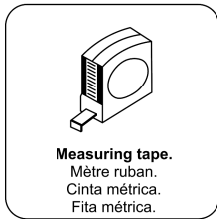
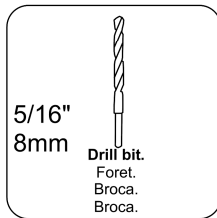
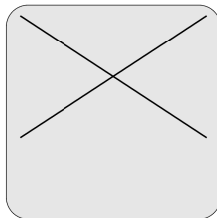
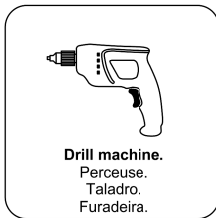
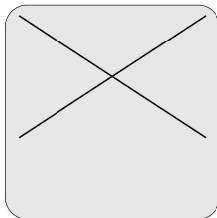
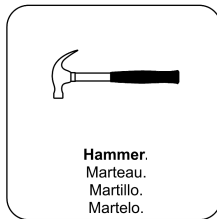
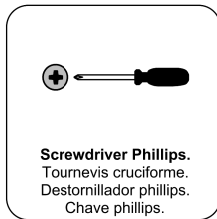
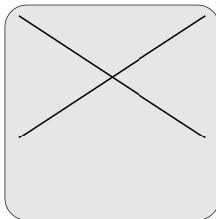
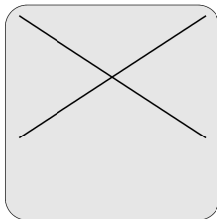

Tools not included

Outils non inclus | Herramientas no incluidas | Ferramentas não inclusas

ACCESSORIES IDENTIFICATION

IDENTIFICATION DES ACCESSOIRES | IDENTIFICACIÓN DE ACCESORIOS
IDENTIFICAÇÃO DOS ACESSÓRIOS

A  30mm Qty./Qtd. **36**
Wooden dowel / Chevilles en bois / Taquete / Cavilha

DS  Qty./Qtd. **2**
Lock / Serrure / Cerrar / Fechadura

DV  Qty./Qtd. **2**
Support / Soutien / Soporte / Suporte

DX  Qty./Qtd. **2**
Metal hinge / Charnière / Bisagra / Dobradiça

G  Qty./Qtd. **12**
Simple minifix screw / Vis minifix simple / Tornillo minifix simple / Haste Minifix Simples

H  Qty./Qtd. **12**
Drum lock / Verrouillage du tambour / Tambor minifix / Tambor de Minifix

M  Qty./Qtd. **6**
Metalic angle plates / Support métallique / Suporte de metal / Cantoneira de Metal

N  14mm Qty./Qtd. **28**
Pan head screw / Vis à tête bombée / Tornillo de pan / Parafuso Panela

S  Qty./Qtd. **4**
Bushing / Douille expansive / Tapón / Bucha Plástica

T  60mm Qty./Qtd. **4**
Flanged head screw / Vis à tête bride / Tornillo de cabeza flangeada / Parafuso flangeado

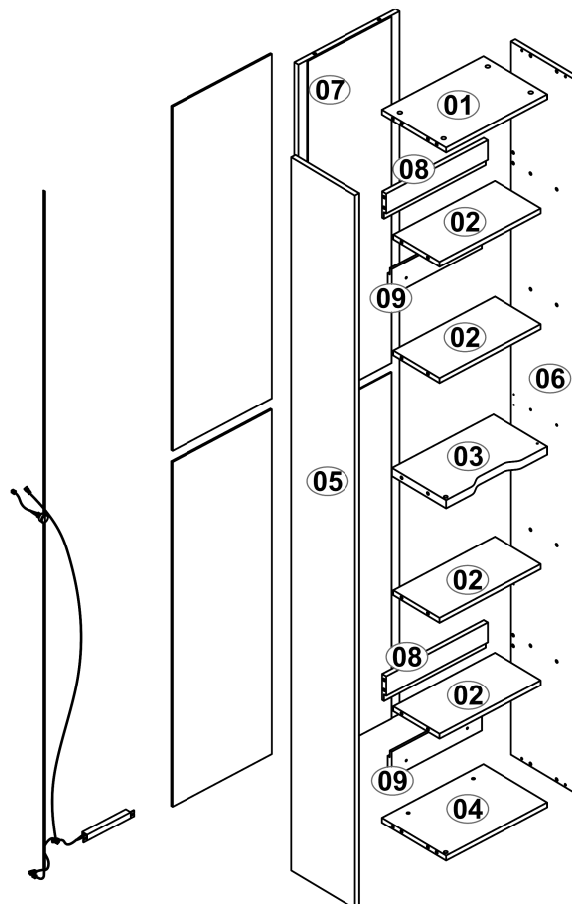

PRE-ASSEMBLY - PRÉ-ASSEMBLAGE - PRE-ARMADO
PRÉ-MONTAGEM

01 -

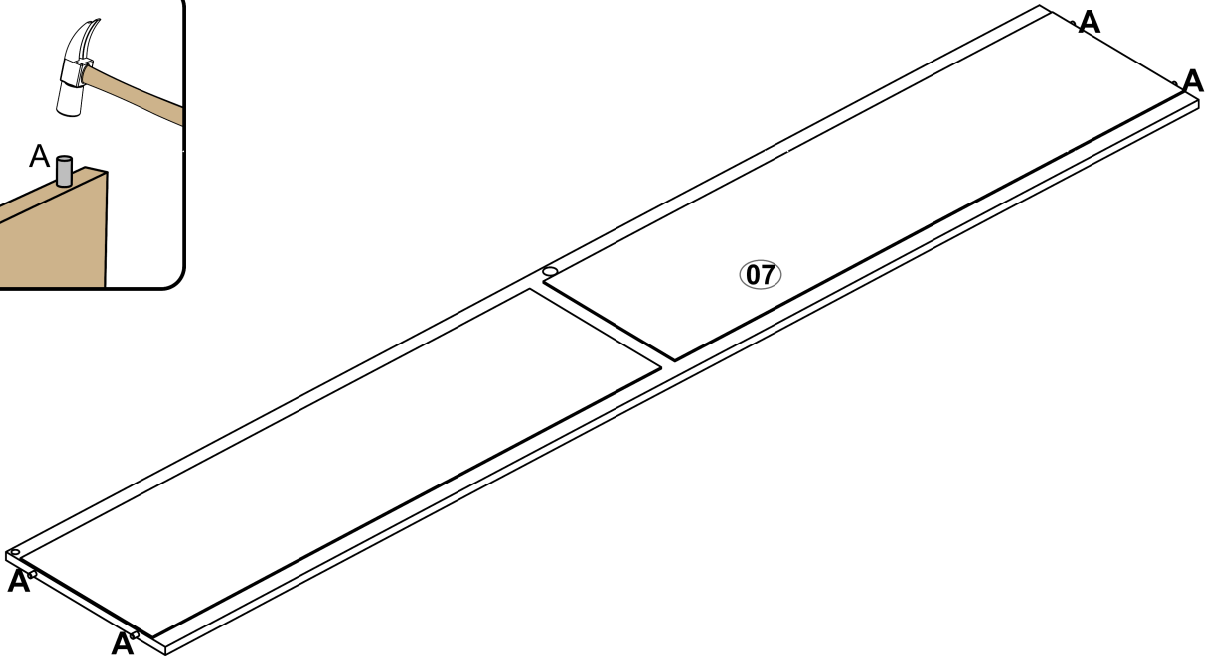
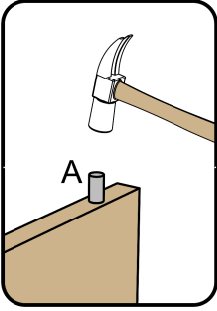

02 -

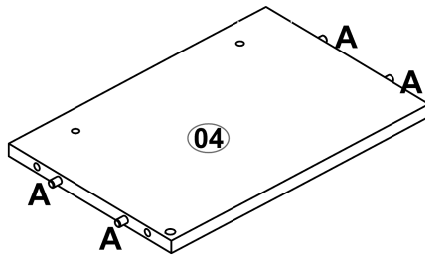
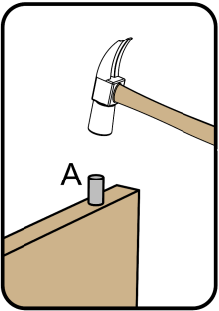

03 -

4x

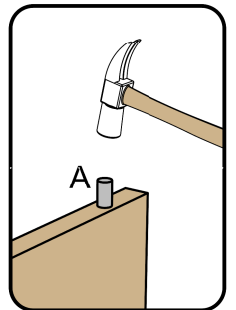
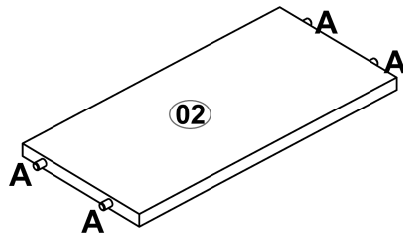

04 -

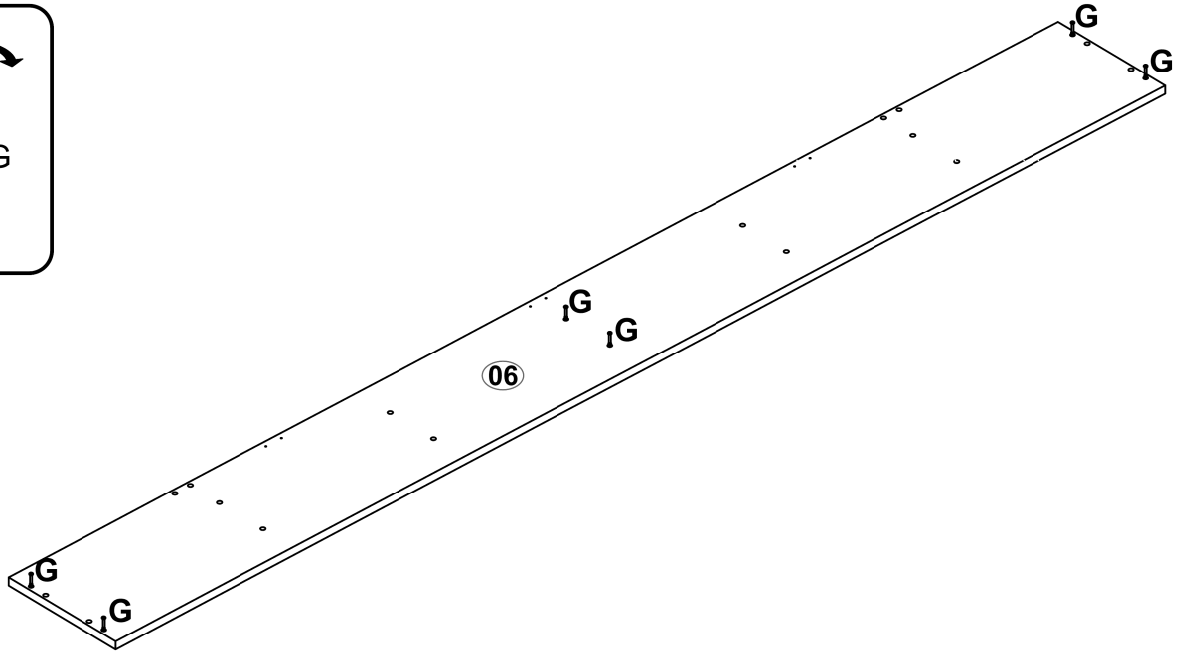
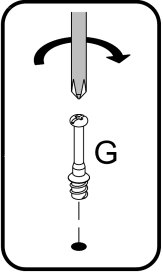

05 -

2x

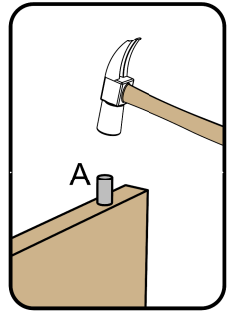
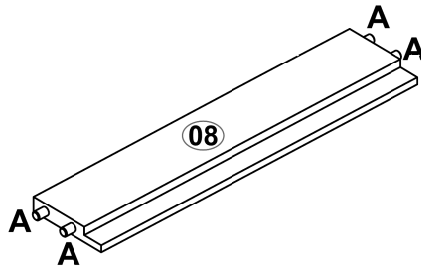

06 -

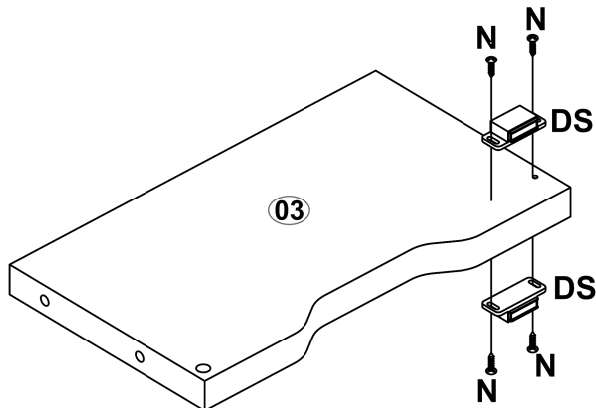

07

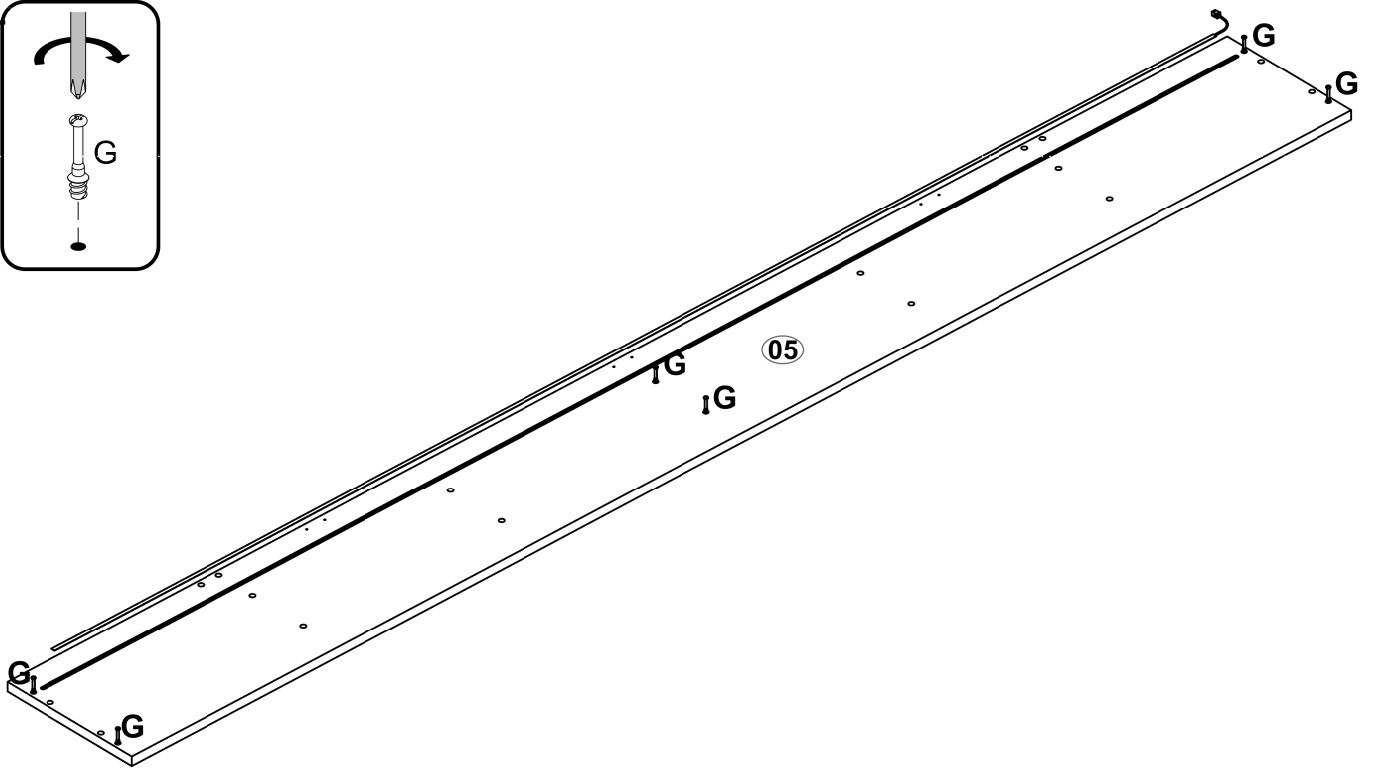
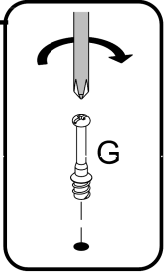

08 -

2x

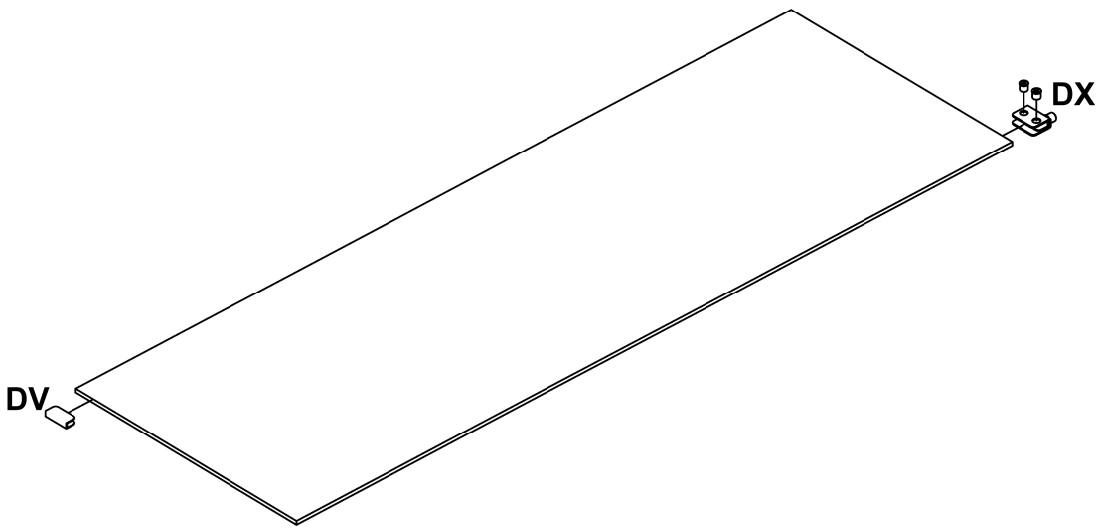

ASSEMBLY - MONTAGE - ARMADO - MONTAGEM

M01 -

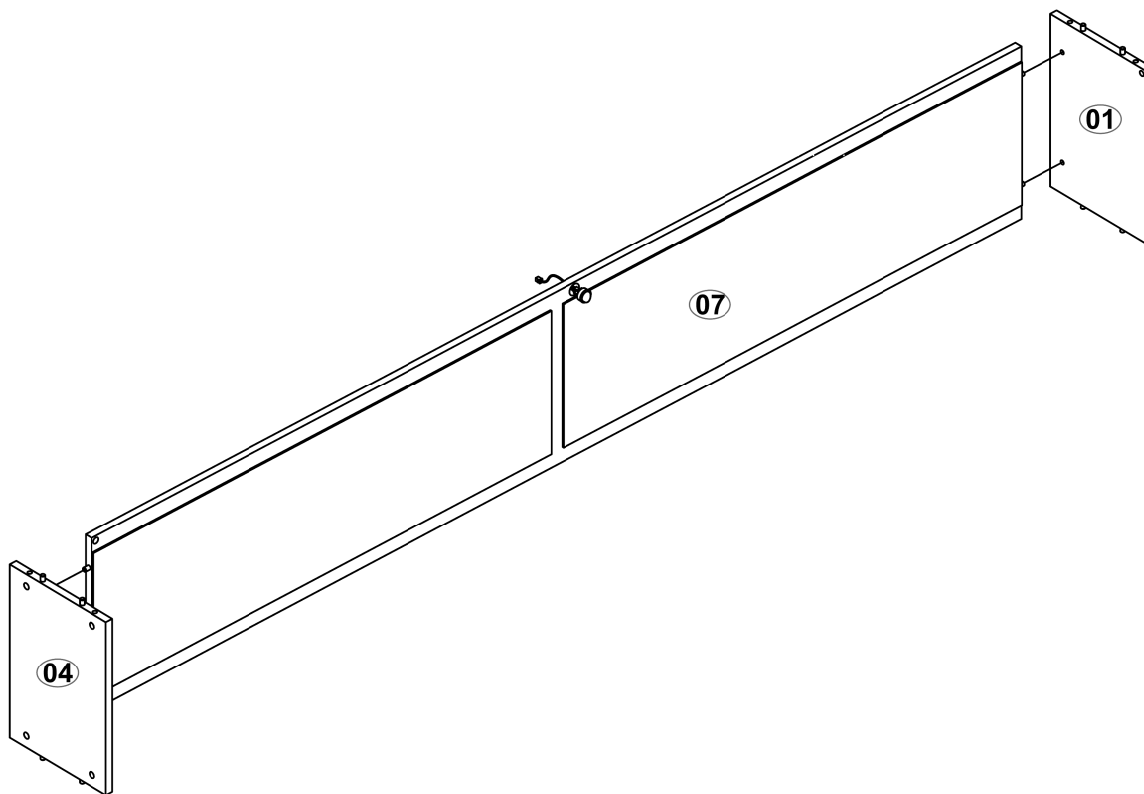

M02 -

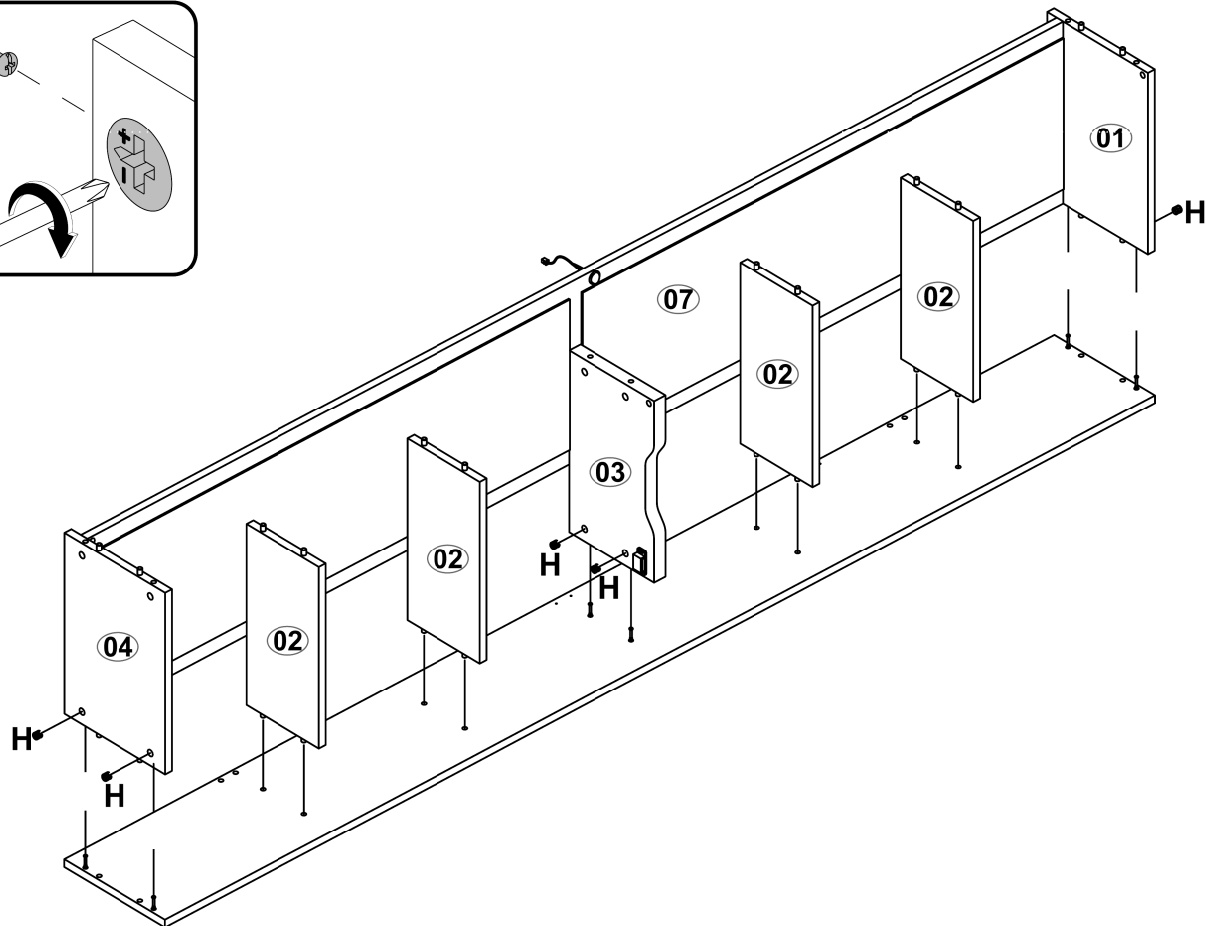
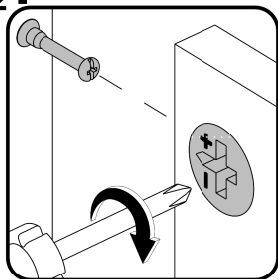

M03 -

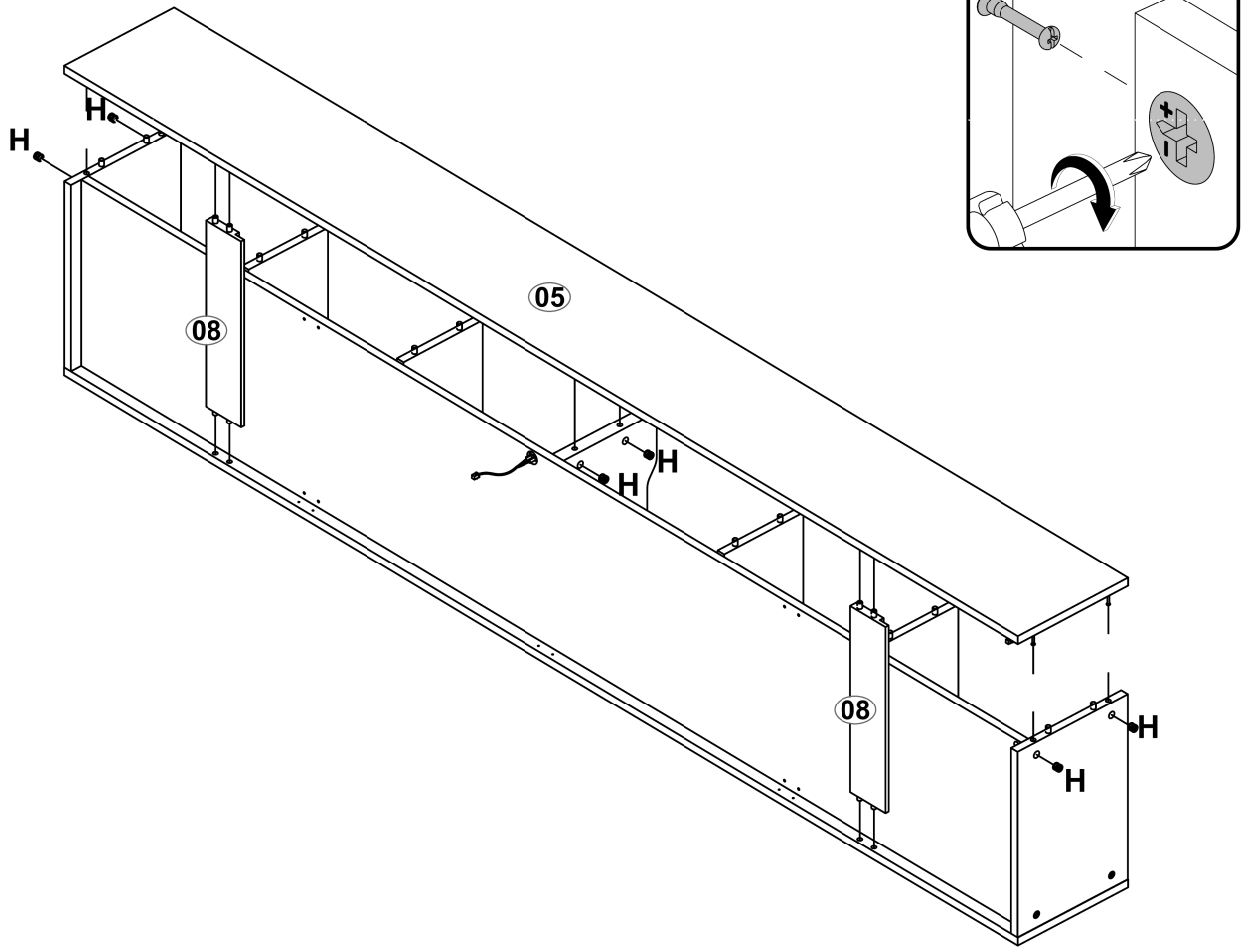

M04 -



M05 -

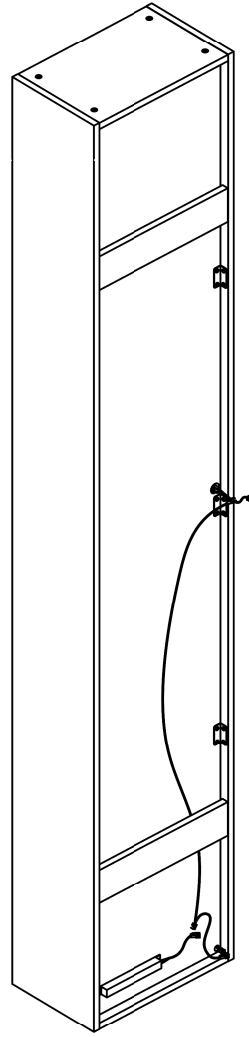

M06 -

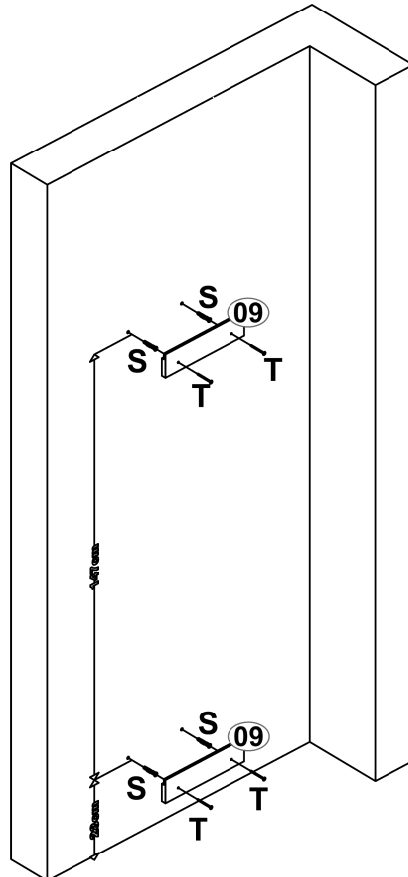
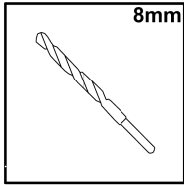
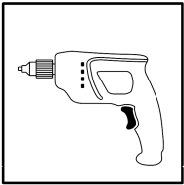

M07 -

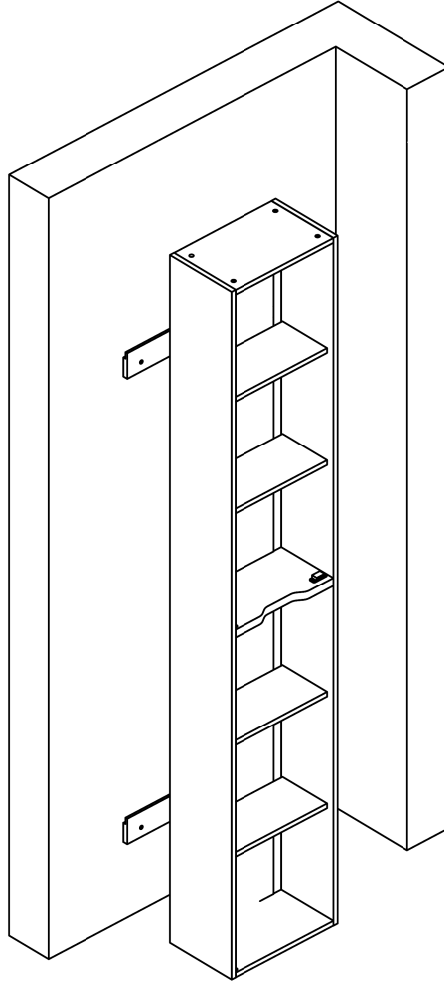

M08 -

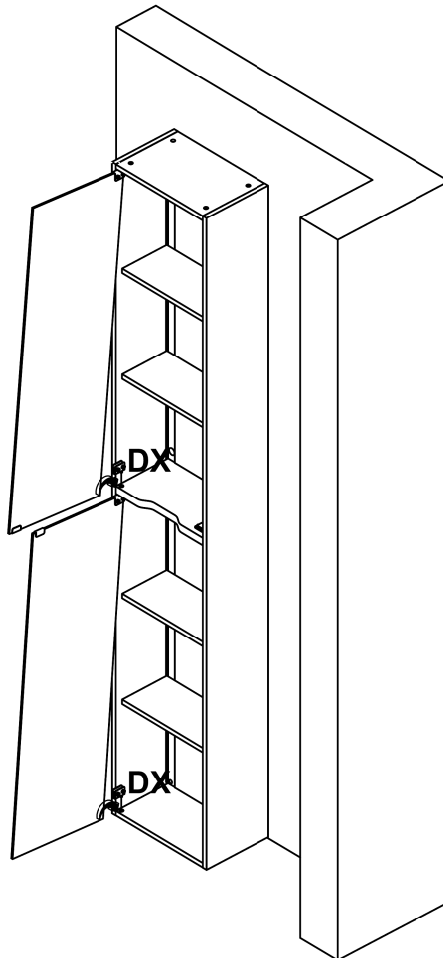

***Note:** Use the stickers and caps to finish.
***Remarque:** Utiliser les autocollants et les capuchons pour terminer la finition.
***Nota:** Utilice los adhesivos y tapas para finalizar el acabado.
***Nota:** Utilize os adesivos e tampas para finalizar o acabamento.

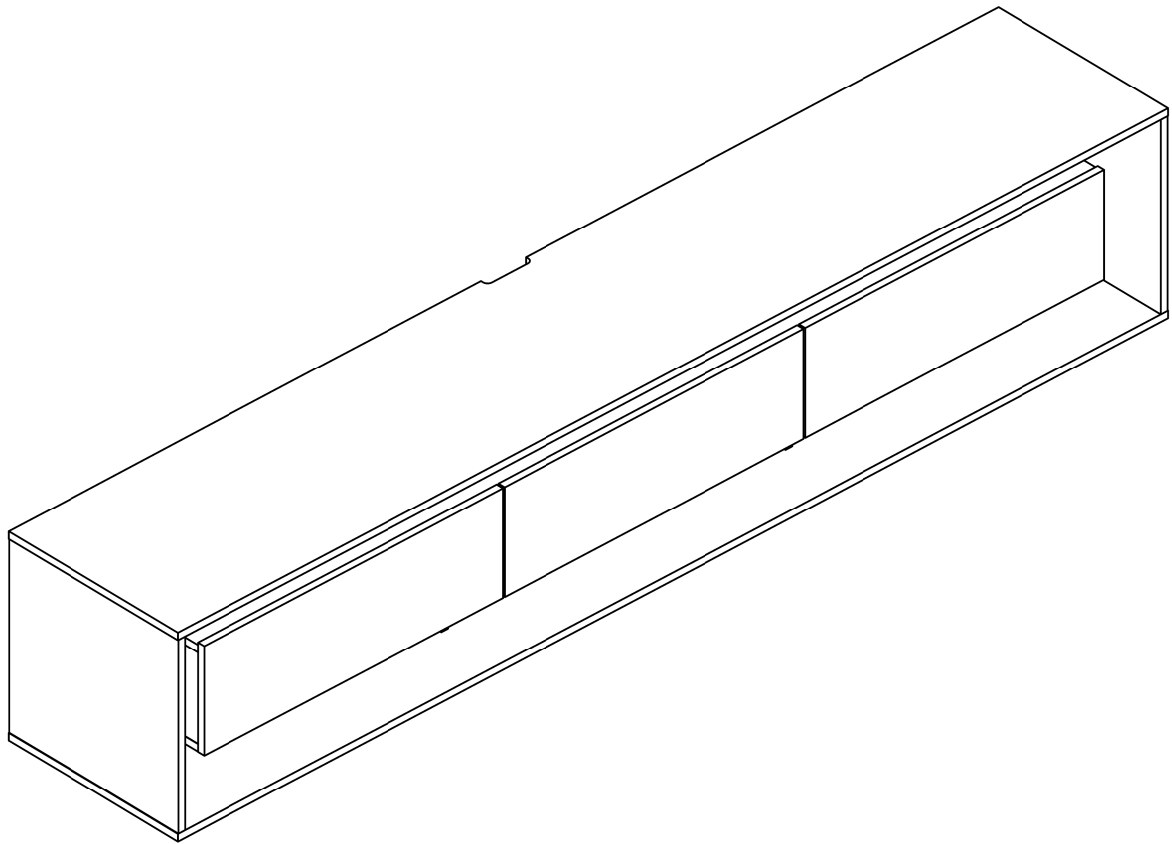

YOU WILL NEED

TU AURAS BESOIN DE | NECESITARÁ | VOCÊ VAI PRECISAR

			<p>Hammer. Marteau. Martillo. Martelo.</p>
	<p>Drill machine. Perceuse. Taladro. Furadeira.</p>		<p>5/16" 8mm Drill bit. Foret. Broca. Broca.</p>
<p>Measuring tape. Mètre ruban. Cinta métrica. Fita métrica.</p>	<p>Pencil. Crayon. Lápiz. Lápis.</p>		<p>2 Person. 2 Personnes. 2 Personas. 2 Pessoas.</p>

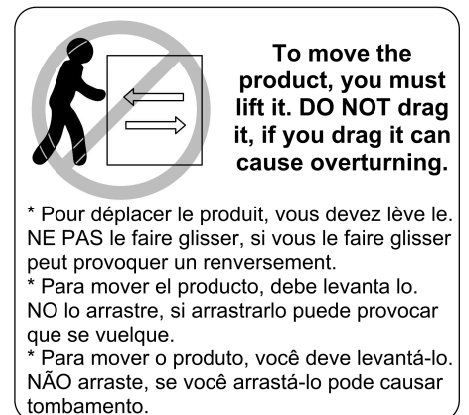
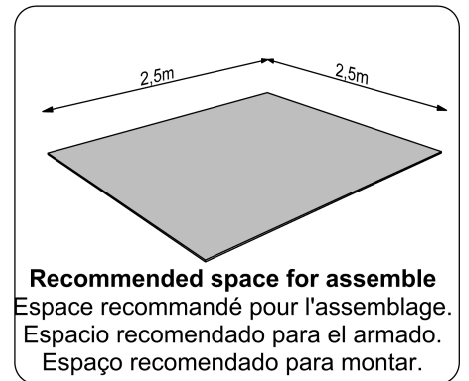

Tools not included

Outils non inclus | Herramientas no incluidas | Ferramentas não inclusas

ACCESSORIES IDENTIFICATION

IDENTIFICATION DES ACCESSOIRES | IDENTIFICACIÓN DE ACCESORIOS
IDENTIFICAÇÃO DOS ACESSÓRIOS

A  30mm Qty./Qtd. **32**
Wooden dowel / Chevilles en bois / Taquete / Cavilha

AY  Qty./Qtd. **2**
Wire finishing / Passer le fil / Cubierta de cableado / Passa Fios

BA  Qty./Qtd. **4**
Sheet metal / Tôle / Lámina de metal / Chapa de metal

C  45mm Qty./Qtd. **20**
Structural screw / Vis à tête structurelle / Tornillo estructural / Parafuso Estrutural

CT  Qty./Qtd. **4**
Metallic bracket / Support métallique / Suporte de metal

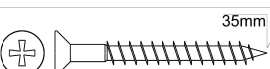
CU  35mm Qty./Qtd. **9**
Structural screw / Vis à tête structurelle / Tornillo estructural / Parafuso Estrutural

E  Qty./Qtd. **4**
Metallic bracket / Support métallique / Suporte de metal

G  Qty./Qtd. **28**
Simple minifix screw / Vis minifix simple / Tornillo minifix simple / Haste Minifix Simples

H  Qty./Qtd. **28**
Drum lock / Verrouillage du tambour / Tambor minifix / Tambor de Minifix

J  10 x 10 Qty./Qtd. **33**
Nail / Ongle / Clavo / Prego

M  Qty./Qtd. **8**
Metalic angle plates / Support métallique / Suporte de metal / Cantoneira de Metal

N  14mm Qty./Qtd. **111**
Pan head screw / Vis à tête bombée / Tornillo de pan / Parafuso Panela

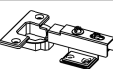
Q  35mm Qty./Qtd. **6**
Metal hinge straight / Charnière métallique droite / Bisagra recta / Dobradiça Reta

R  Qty./Qtd. **4**
Metalic bracket / Support métallique / Soporte de metal / Suporte de Metal

S  Qty./Qtd. **4**
Bushing / Douille expansive / Tapón / Bucha Plástica

T  60mm Qty./Qtd. **4**
Flanged head screw / Vis à tête bride / Tornillo de cabeza flangeada / Parafuso flangeado

Z  Qty./Qtd. **4**
Metal claw / Pince de métal / Garra metal / Garra de Metal

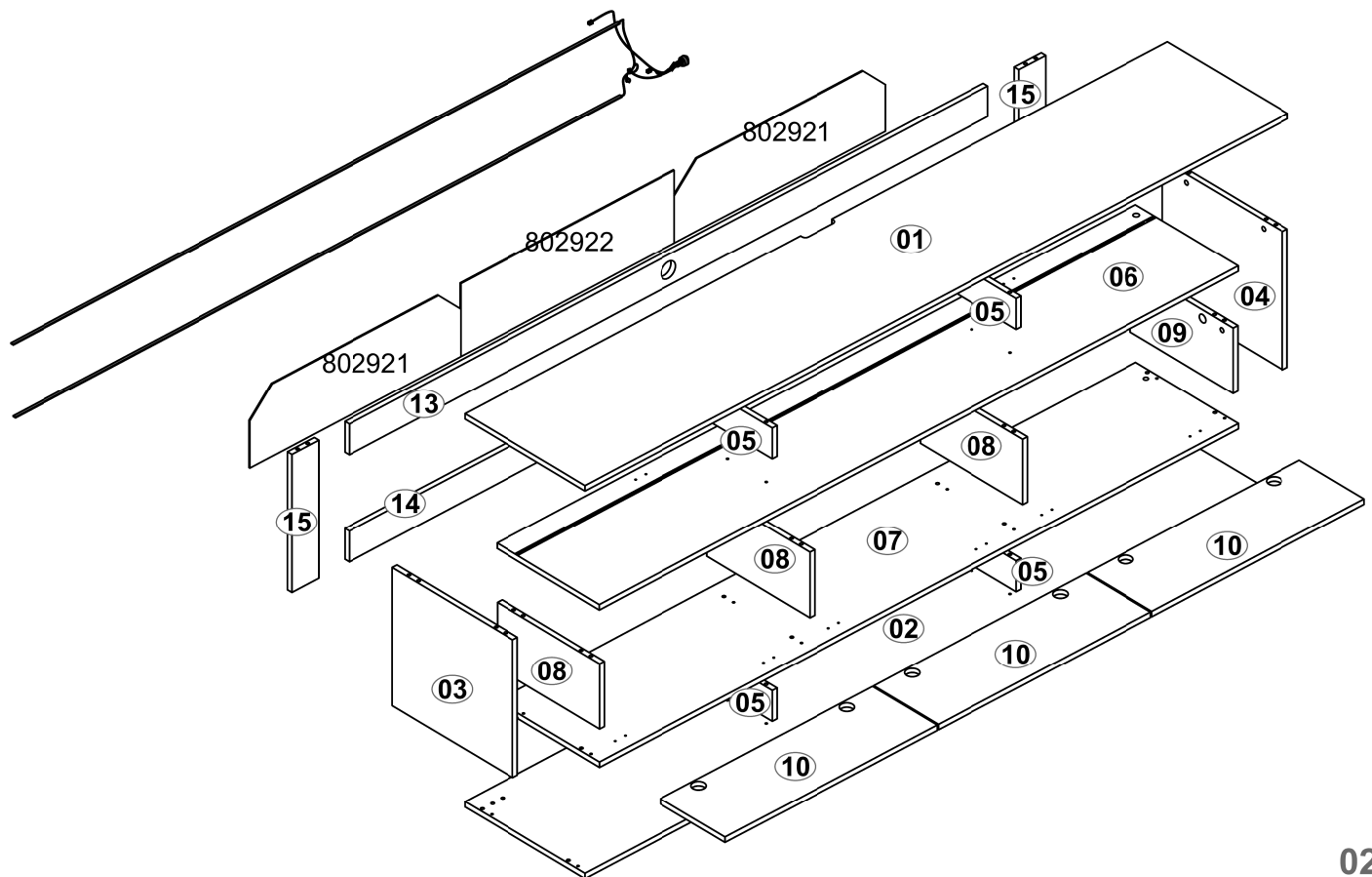

PRE-ASSEMBLY - PRÉ-ASSEMBLAGE - PRE-ARMADO
PRÉ-MONTAGEM

01 -

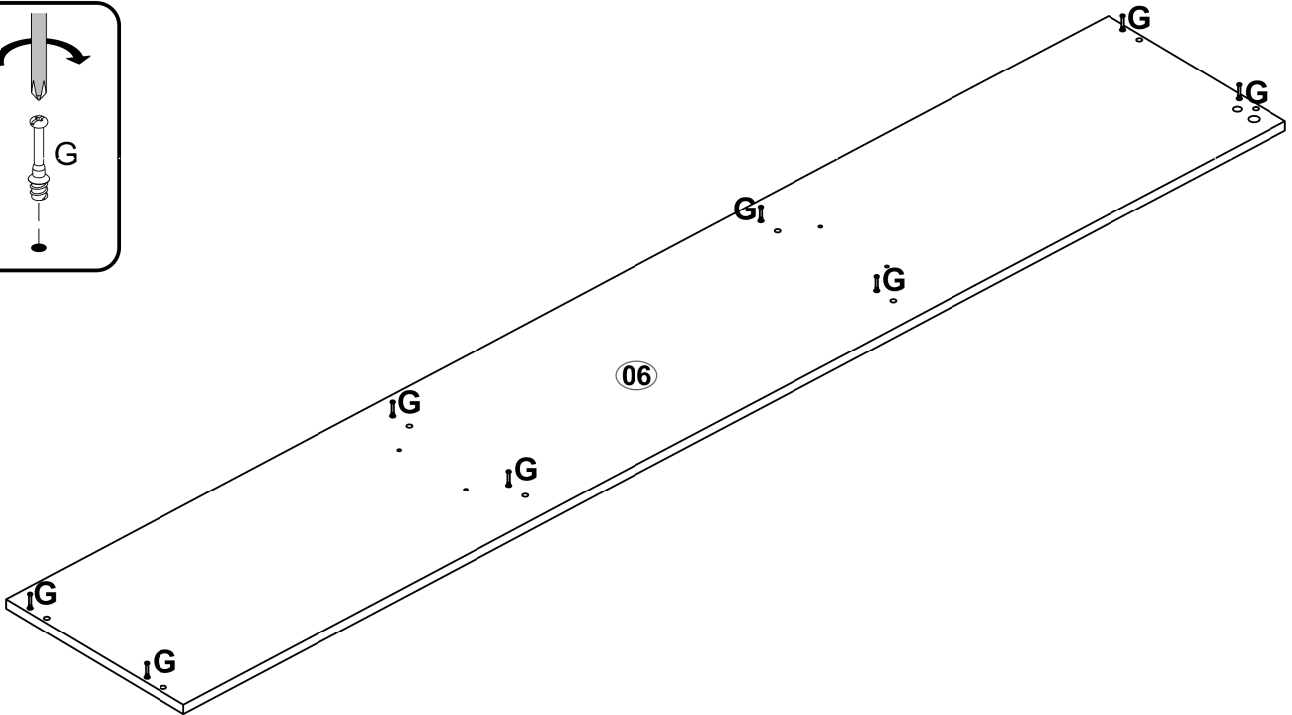
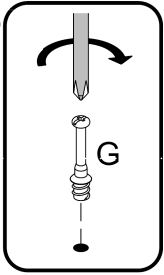

02 -

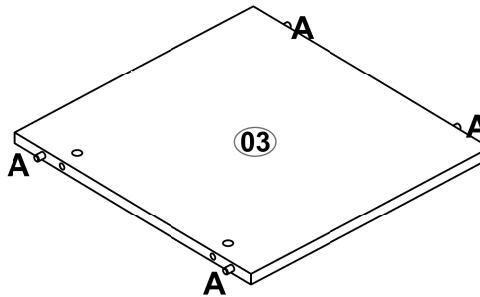
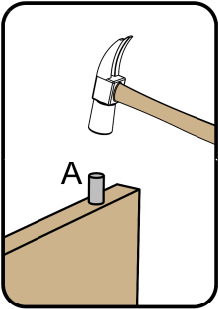

03 -

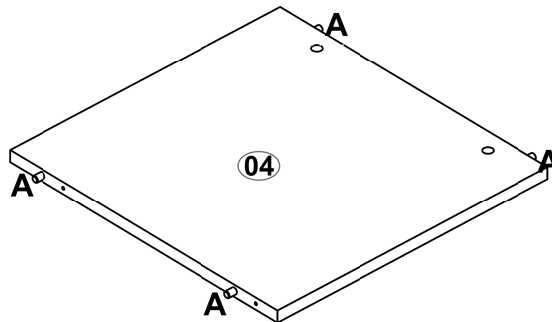
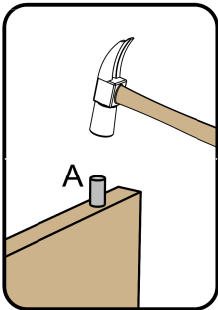

04 -

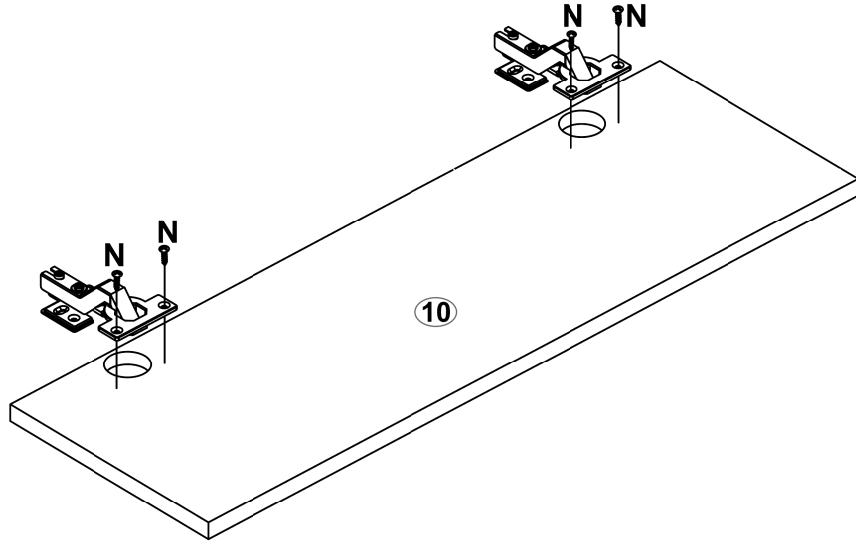

05 -

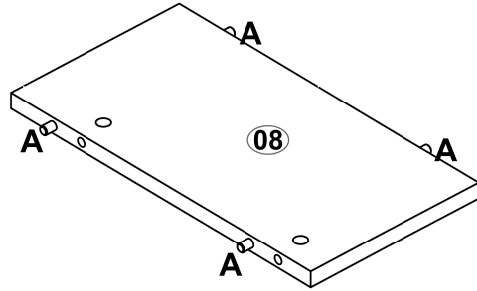
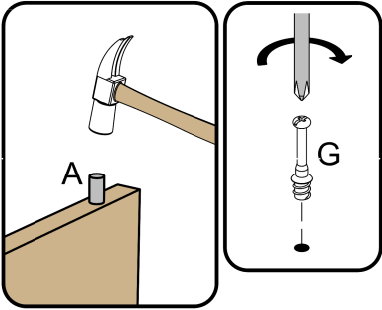

06 -

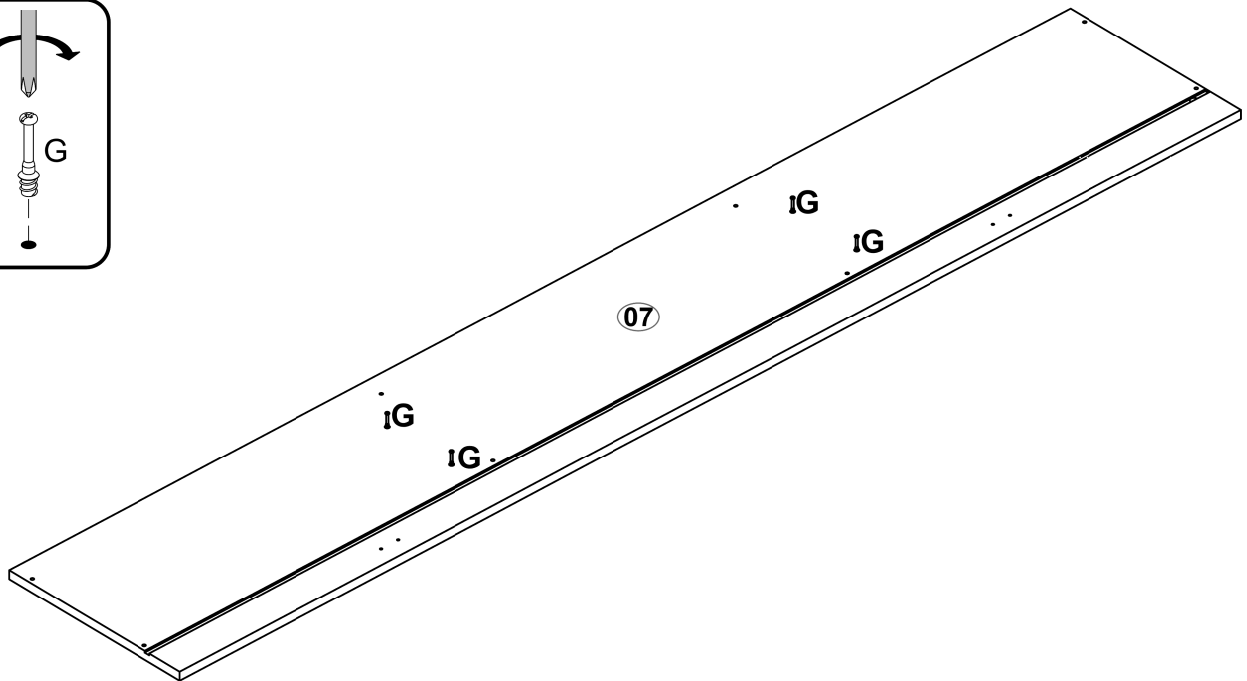
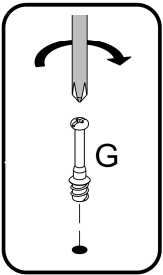

07 -

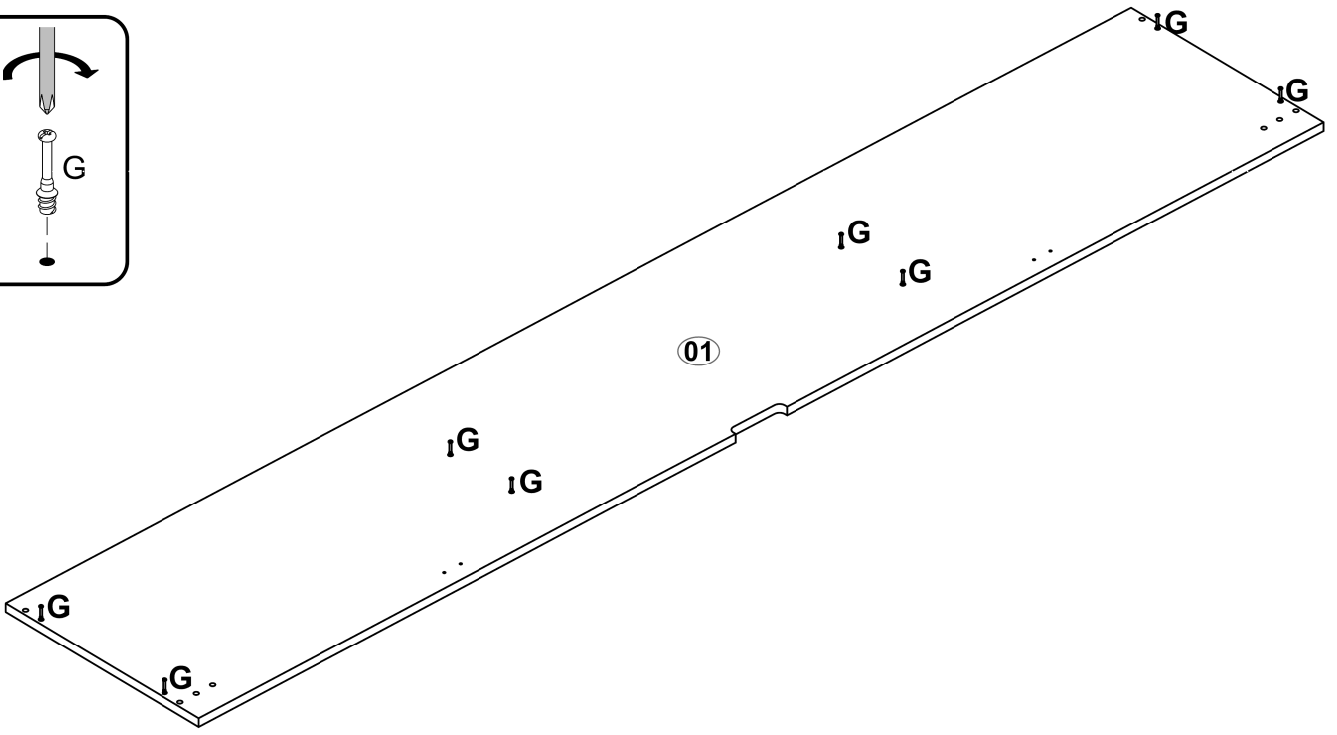
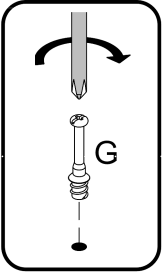

08 -

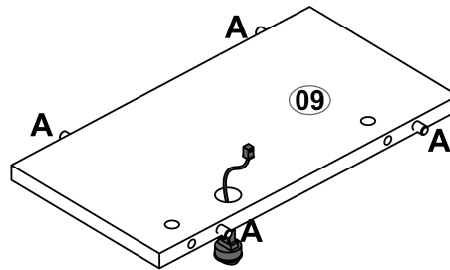
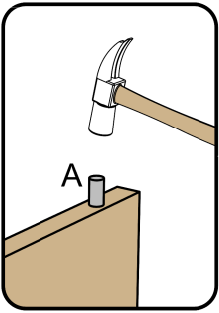

09 -

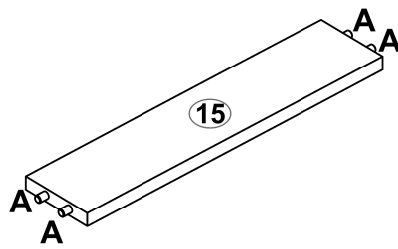
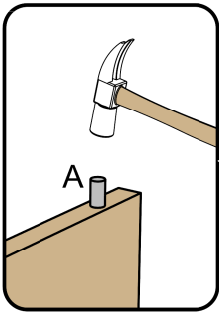

ASSEMBLY - MONTAGE - ARMADO - MONTAGEM

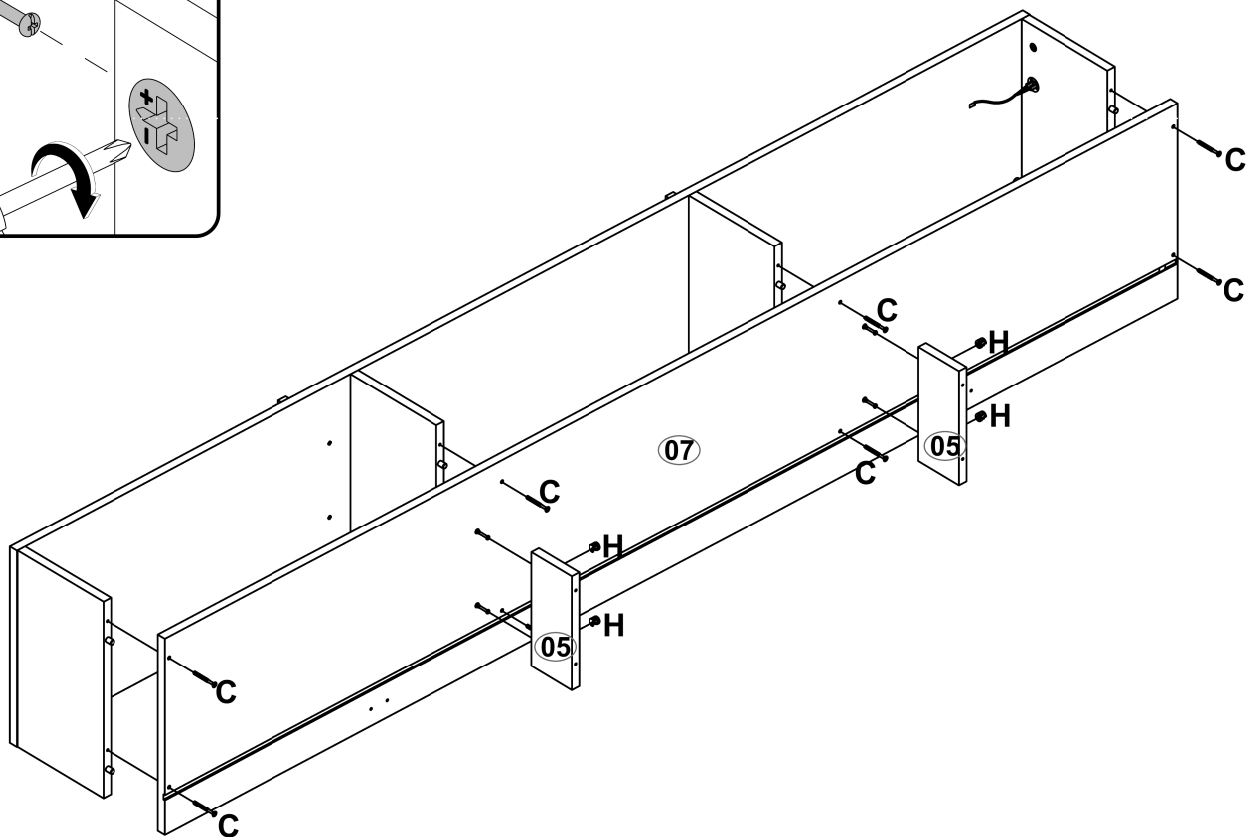
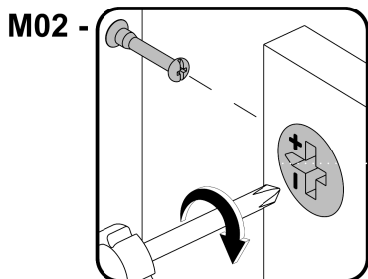
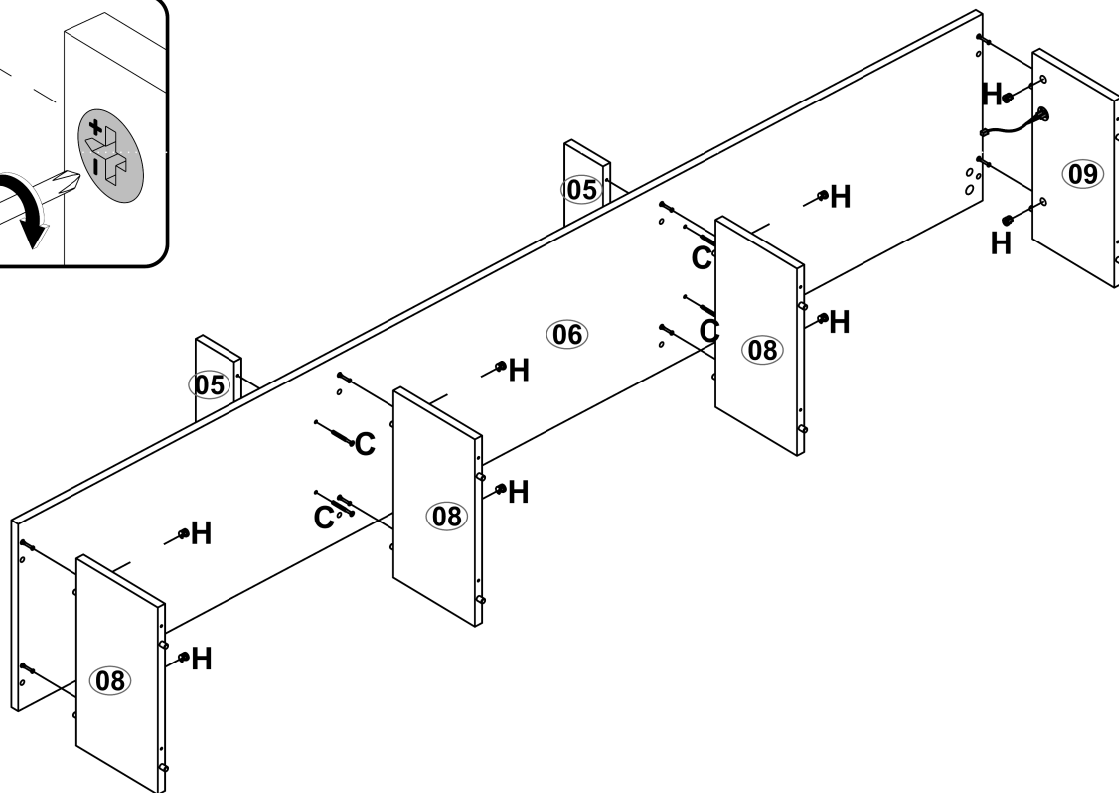
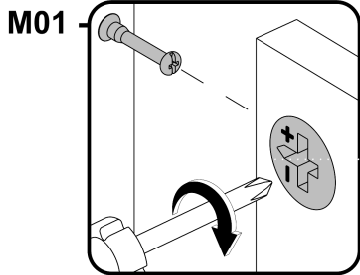

M03 -

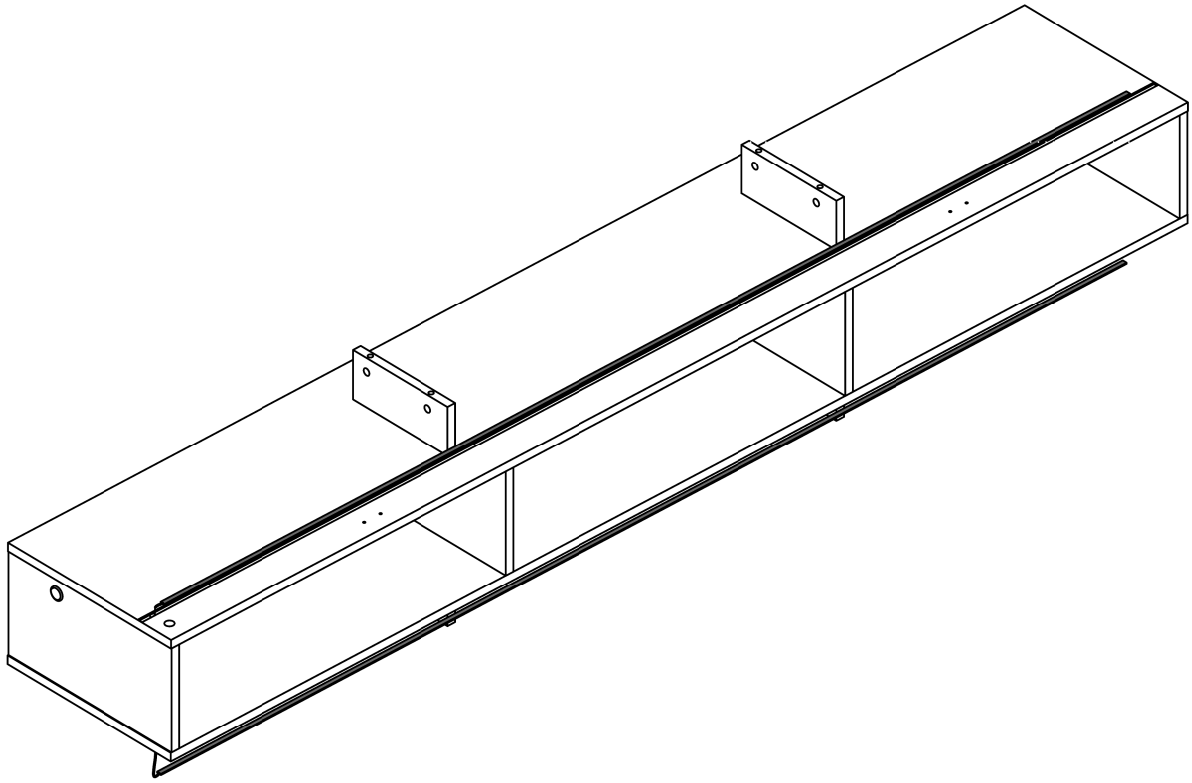

M04 -

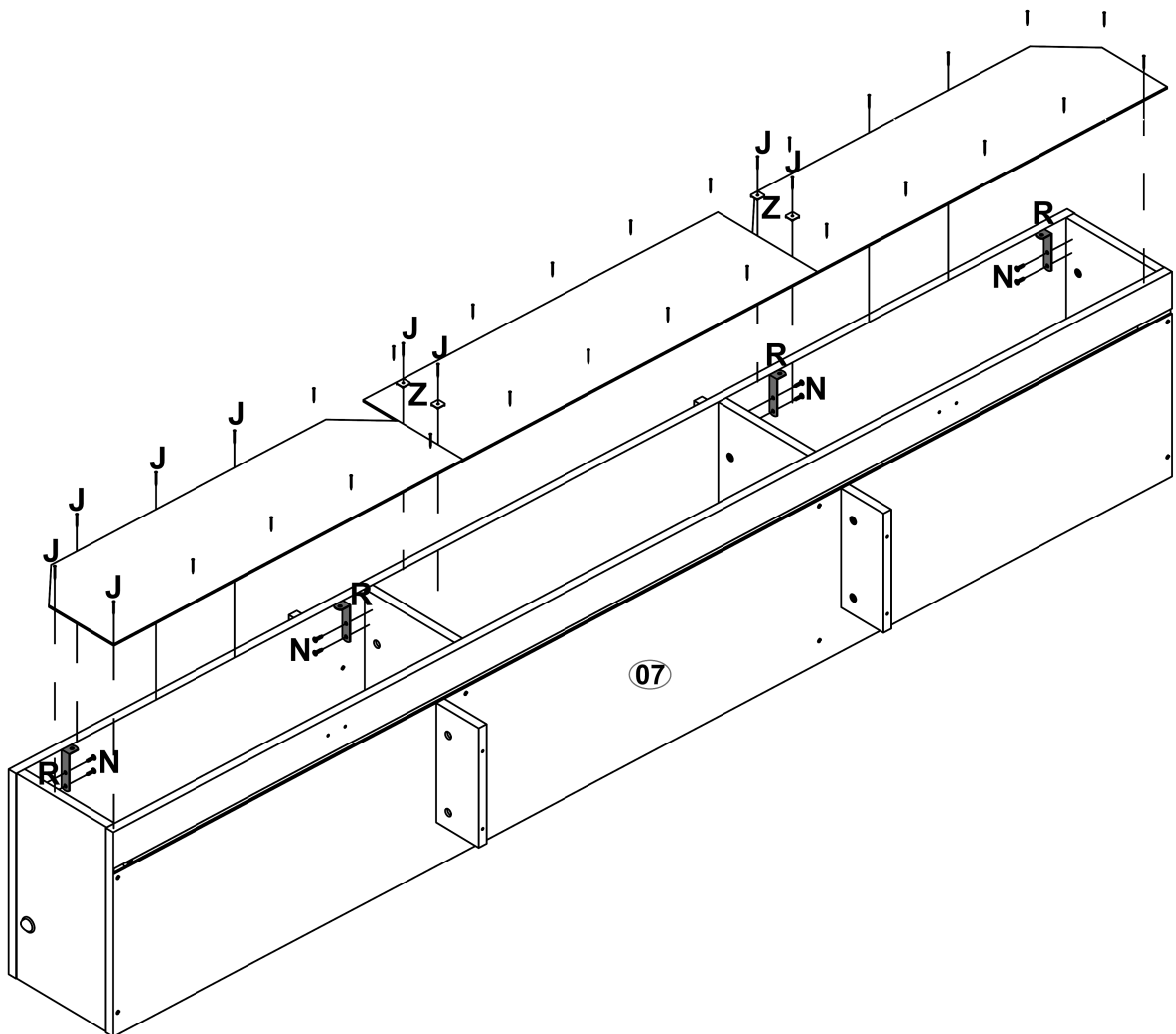

M05 -

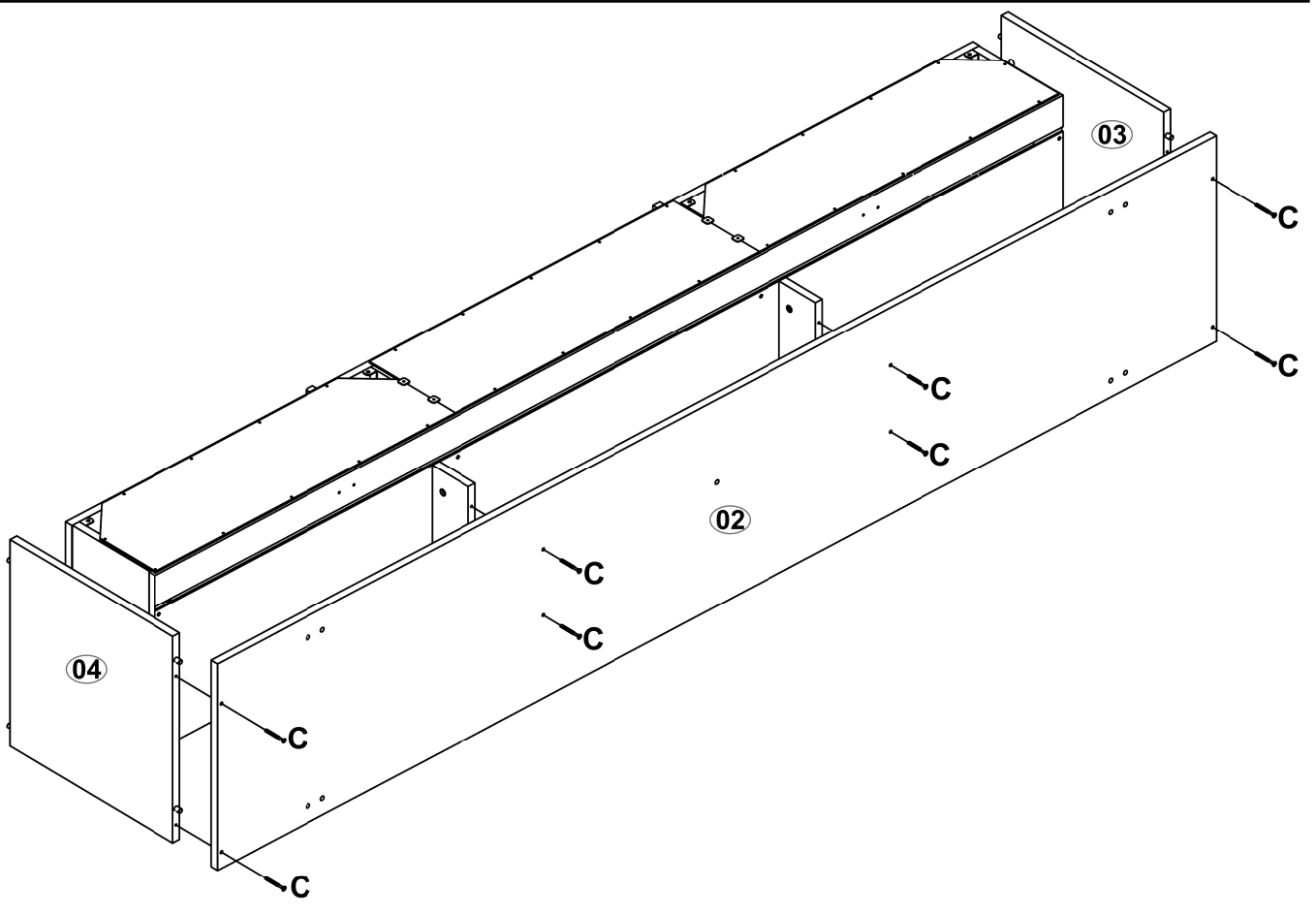

M06 -

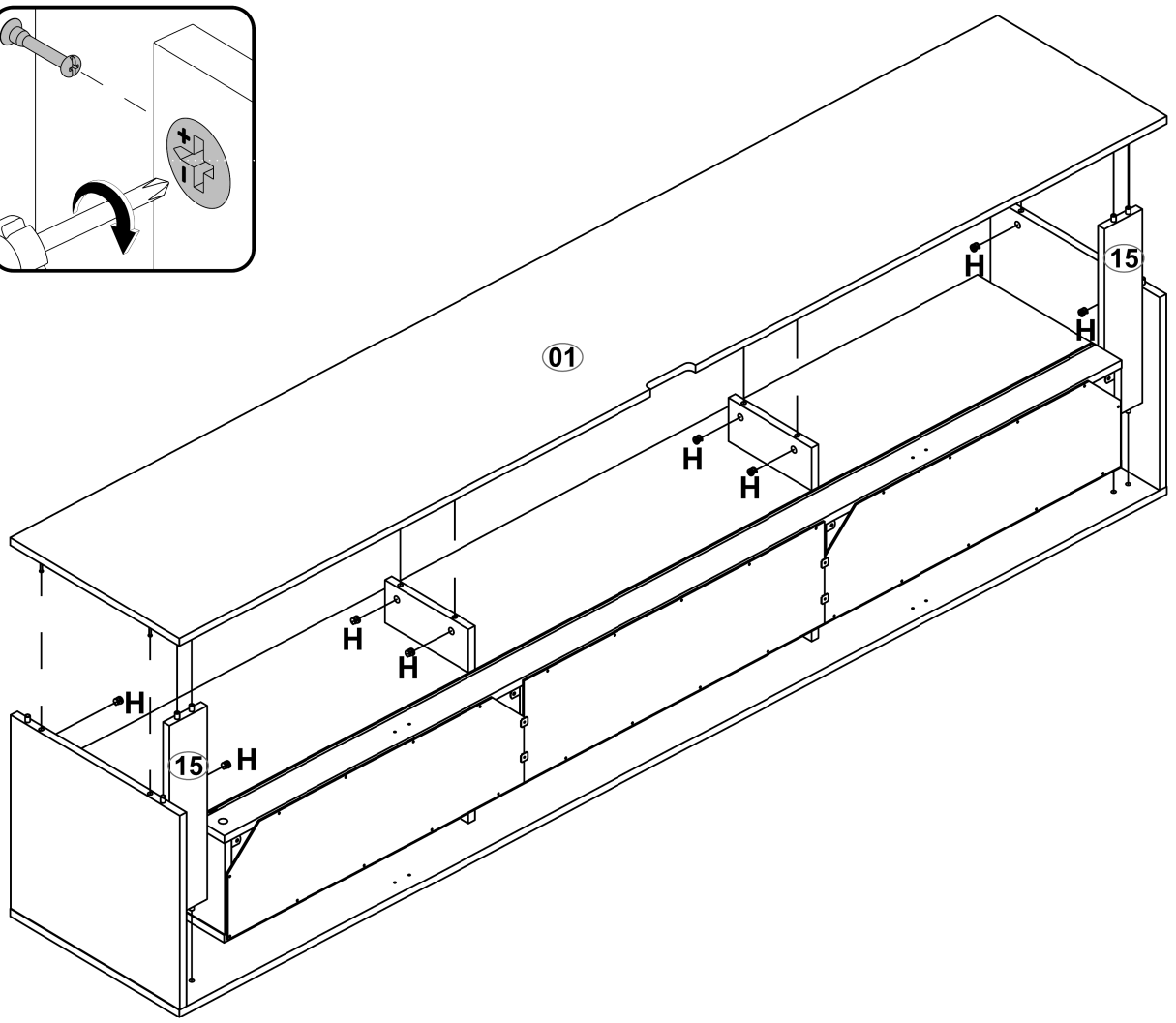
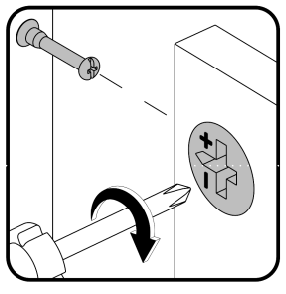

M07 -

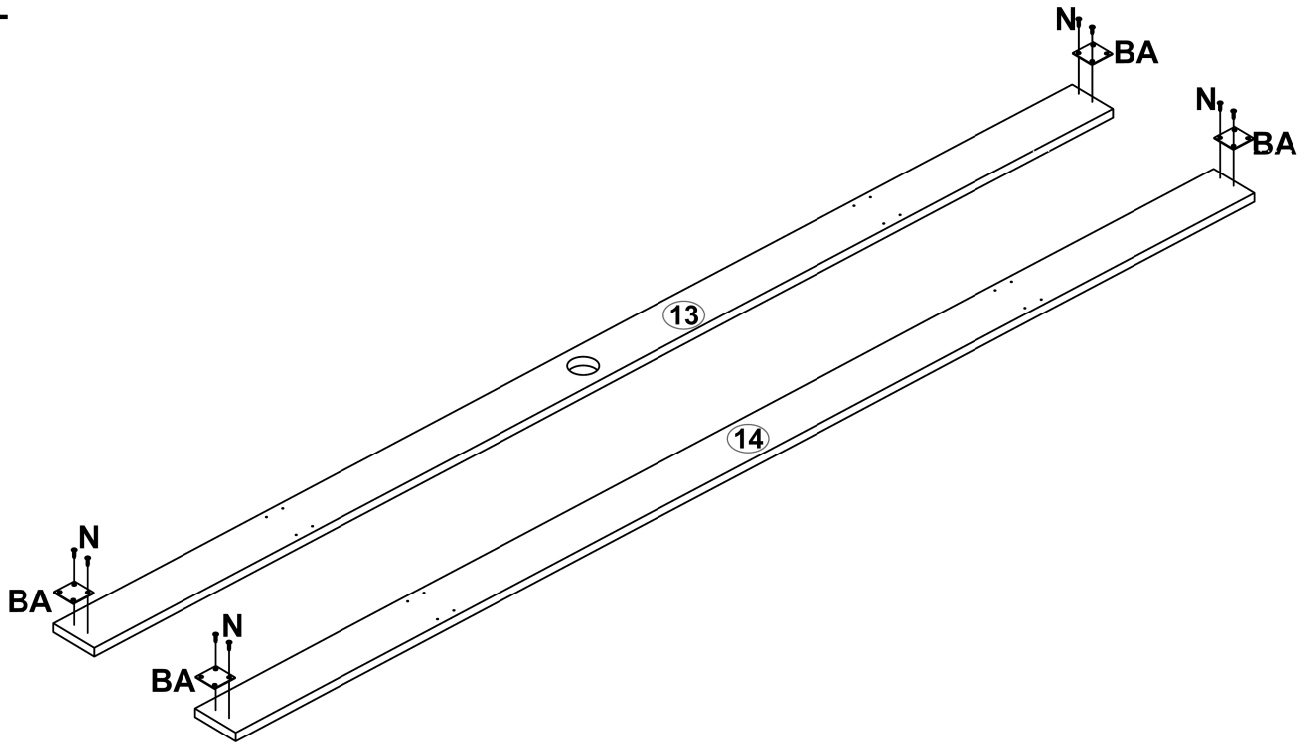

M08 -

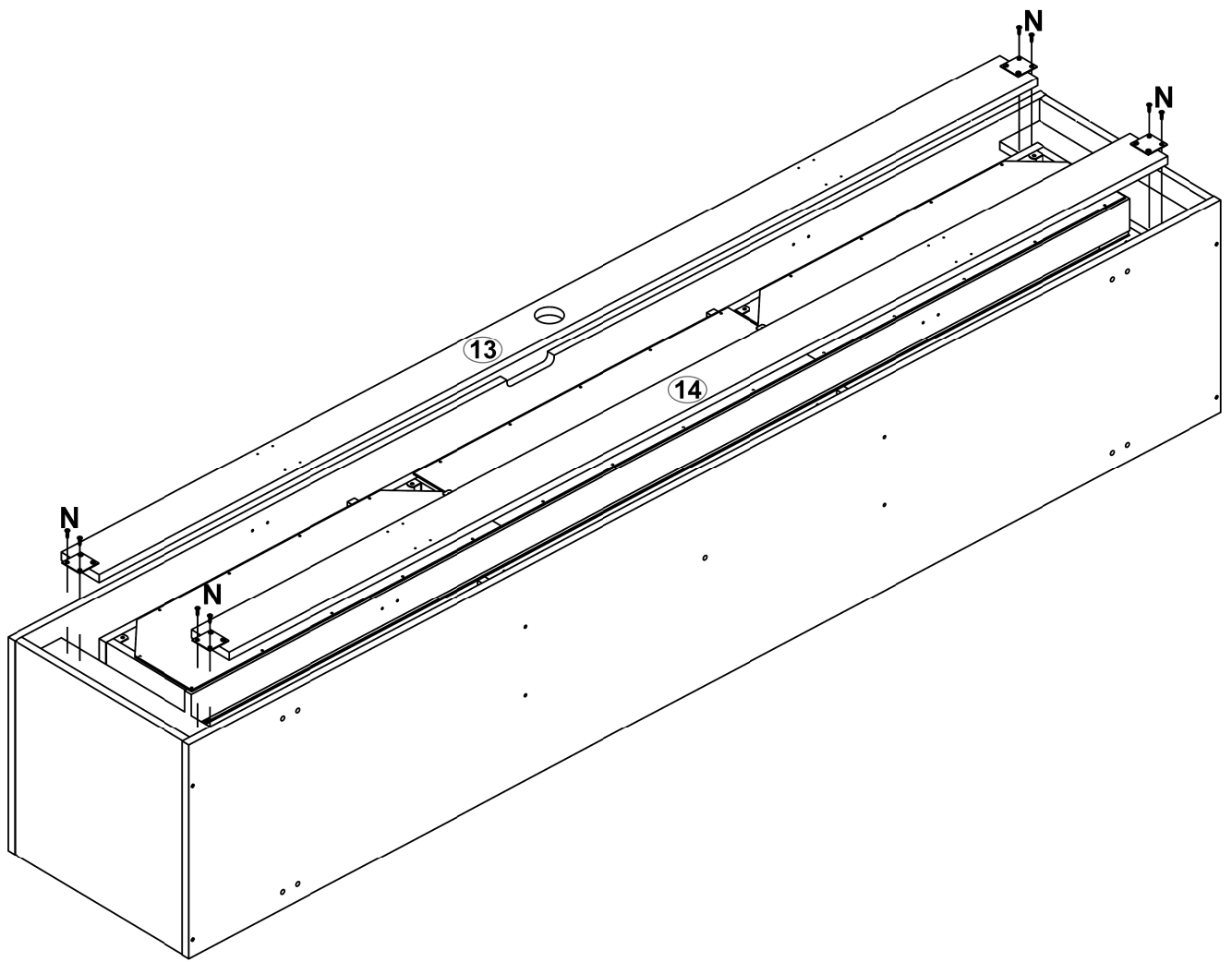

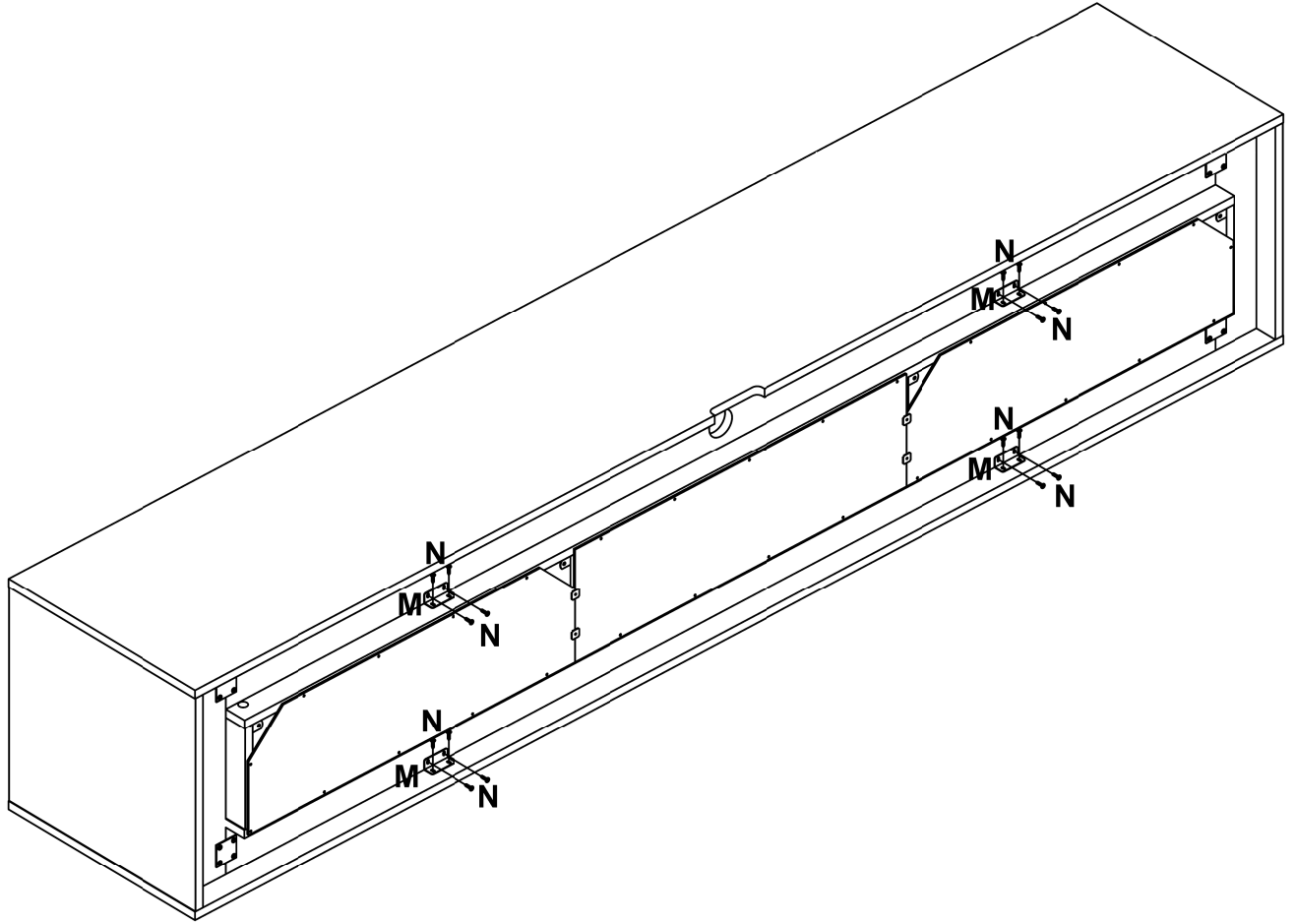

M09 -

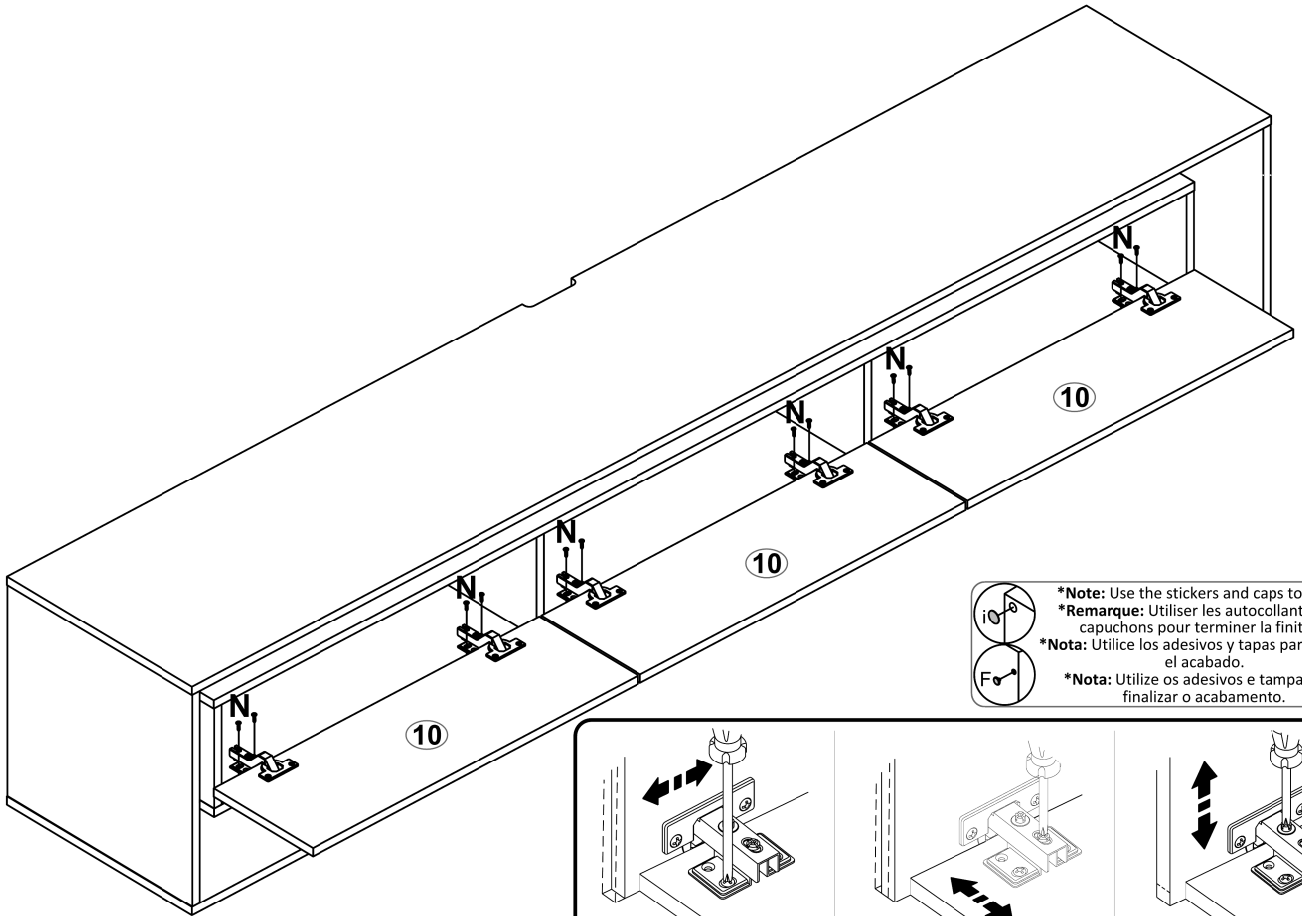

M10 -

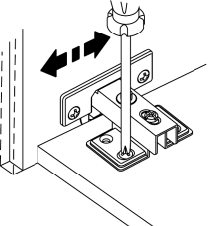
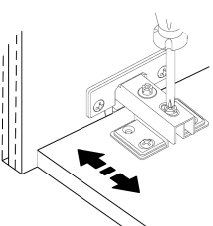
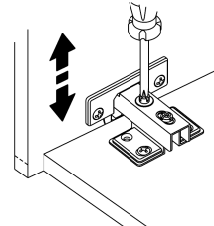

 ***Note:** Use the stickers and caps to finish.
***Remarque:** Utiliser les autocollants et les capuchons pour terminer la finition.
 ***Nota:** Utilice los adhesivos y tapas para finalizar el acabado.
 ***Nota:** Utilize os adesivos e tampas para finalizar o acabamento.

		
Horizontal Adjustment Regulagem Horizontal Ajuste Horizontal Ajuste Horizontal	Depth Adjustment Regulagem Profundidade Ajuste Profundidad Ajuste de Profundidade	Vertical Adjustment Regulagem Vertical Ajuste Vertical Ajuste Vertical

M11 -

MONTAGEM DO RACK COM PÉS EM MADEIRA

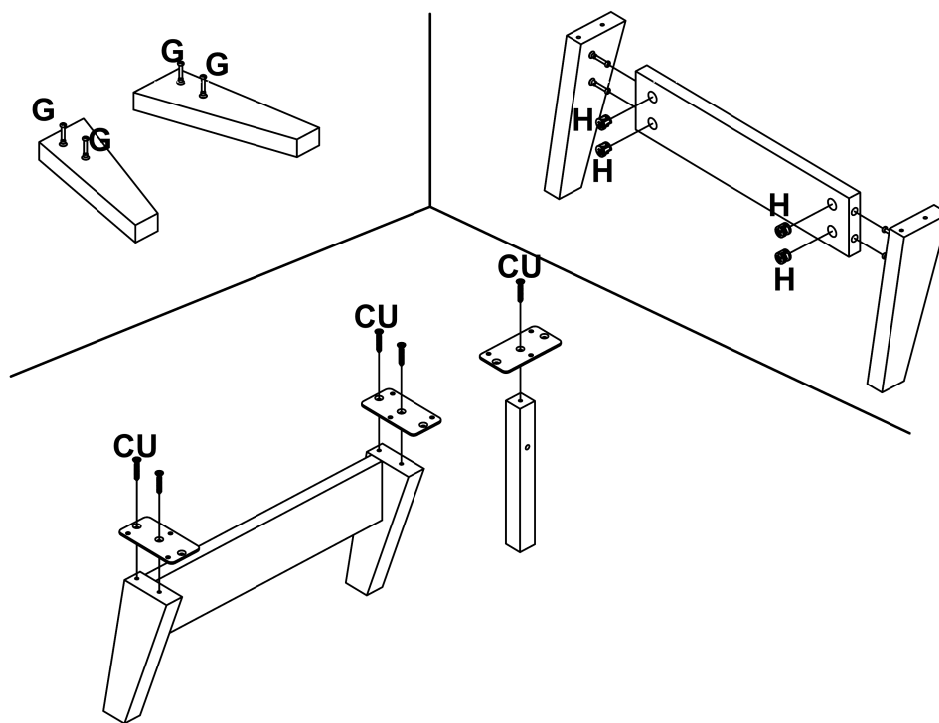

M12 -

