

Fixar as costas (15), com os pregos (R).  
OBS: pregar aproximadamente 10 cm um do outro.

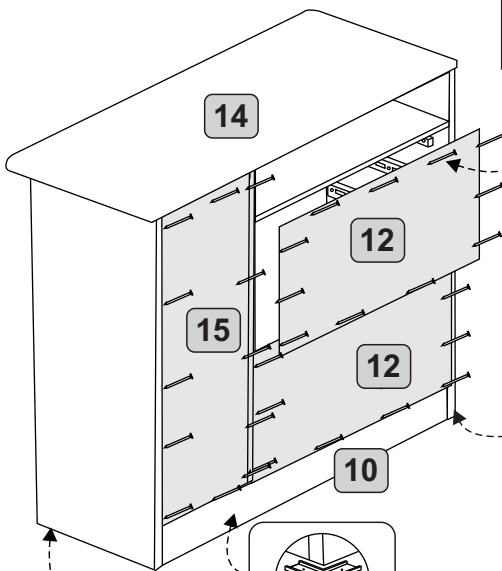

**3º** 3º Passo  
3th Step  
Paso 3

OBS, NÃO SE ESQUEÇA:  
"O ESQUADRO DO MÓVEL  
DEPENDE DA BOA COLOCAÇÃO  
DO FUNDO"

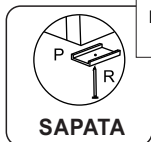

**4º** 4º Passo  
4th Step  
Paso 4

Atenção!!! Utilizar Cola nas  
Cavilhas e Fundo da Gaveta.

Attention! To use Glue in Cavilhas  
and Deep of the Drawer.

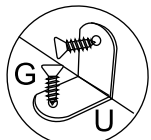

**5º** 5º Passo  
5th Step  
Paso 5

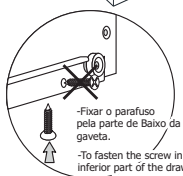
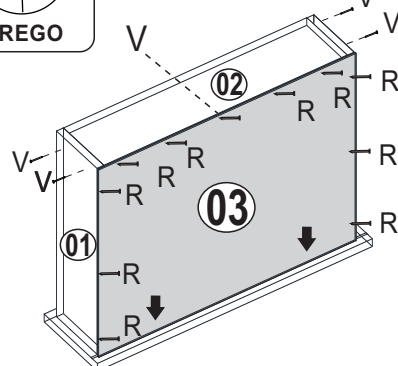
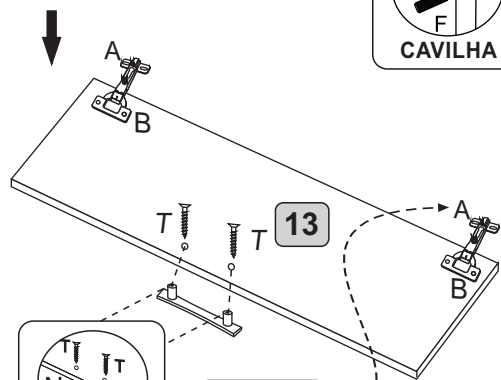

-Fixar o parafuso  
pela parte de Baixo da  
gaveta.  
-To fasten the screw in the  
inferior part of the drawer.

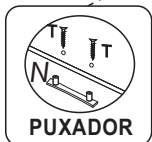
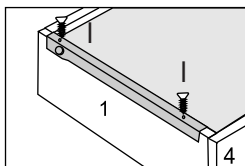

Para Fixar as portas, colocar as dobradiças  
com os calços, para melhor encaixe.



www.rodial.com.br

# INSTRUÇÕES DE MONTAGEM CÔMODA

Instrucciones de armado  
COMODO / COMFORTABLE



COD. FERRAG.: 16599

**L.2018**



**Móveis Rodial Ltda**

Rua João Guadagnin, 5050  
Bairro Industrial I  
CX. Postal 41 - Cep: 95.300-000  
Fone/Fax: (54) 3358 6700  
Lagoa Vermelha-RS - Brasil  
sac@rodial.com.br

www.rodial.com.br

Altura: **1015mm**  
altura: 1015mm

Largura: **950mm**  
ancho: 950 mm

Profundidade: **425mm**  
profundidad: 425mm

**Pessoas Necessárias para montagem**  
las personas necesarias para el montaje



1 Pessoa / 1 persona

(Não Fornecidas)  
(No se proporcionaron)

**Ferramentas para a montagem**  
Herramientas para el montaje



Martelo  
martillo



Chave Philips ou  
Parafusadeira  
Destornillador Philips o una llave

- Ler e observar atentamente toda a instrução antes de iniciar a montagem.
- A montagem do produto deverá ser feita em superfície limpa e plana.
- Aconselhamos utilizar a embalagem para forrar o chão a fim de não danificar o produto.
- Evitar batidas e o contato com objetos cortantes.
- Observar as cargas máximas suportadas de acordo com o desenho.

## LIMPEZA









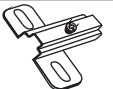

- Pano levemente umedecido com água seguido de pano seco.
- Não utilizar produtos químicos e abrasivos.

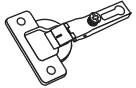
## ATENCIÓN

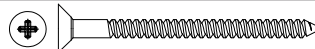
- Lea y siga todas las instrucciones cuidadosamente antes de iniciar el montaje.
- El montaje del producto debe estar en una superficie limpia y plana.
- Recomienda utilizar el embalaje para cubrir el suelo con el fin de no dañar producto.
- Eviten los golpes y el contacto con objetos punzantes.

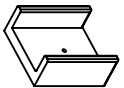
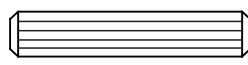
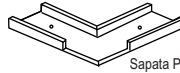
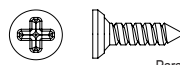
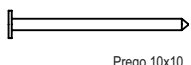
## LIMPIEZA

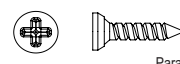
- Paño ligeramente humedecido con agua, seguido por un paño seco.
- No utilice productos químicos y abrasivos.

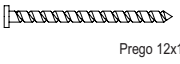
<b>A</b>		cod.peça 3384	<b>L</b>		cod.peça 10425
<b>B</b>		cod.peça 3384	<b>M</b>		cod.peça 10722
<b>C</b>		cod.peça 3986	<b>O</b>		cod.peça 11409
<b>D</b>		cod.peça 3991	<b>P</b>		cod.peça 17651
<b>F</b>		cod.peça 3881	<b>Q</b>		cod.peça 3988
<b>G</b>		cod.peça 3385	<b>R</b>		cod.peça 3875
<b>H</b>		cod.peça 2493	<b>T</b>		cod.peça 12114
<b>I</b>		cod.peça 5738	<b>U</b>		cod.peça 3882
<b>J</b>		cod.peça 3872	<b>V</b>		cod.peça 3876
		<b>02 unid.</b>			<b>06 unid.</b>
		<b>02 unid.</b>			<b>01 unid.</b>
		<b>18 unid.</b>			<b>02 unid.</b>
		<b>18 unid.</b>			<b>04 unid.</b>
		<b>26 unid.</b>			<b>02 unid.</b>
		<b>42 unid.</b>			<b>100 unid.</b>
		<b>05 C.J.</b>			<b>12 unid.</b>
		<b>60 unid.</b>			<b>13 unid.</b>
		<b>02 unid.</b>			<b>25 unid.</b>

RELAÇÃO DE PEÇAS Relation of pieces Relación de piezas		QUANT. Quant. Cuant.	RELAÇÃO DE PEÇAS Relation of pieces Relación de piezas		QUANT. Quant. Cuant.
1	Lateral gaveta Lateral cajón Drawer side	360X92X12mm	10	10	Rodapé traseiro Rodapié trasero Back baseboard
2	Traseira gaveta Trasero cajón Drawer back	535X75X15mm	5	11	Divisão División División
3	Fundo gaveta Fondo cajón Front drawer	558X363X3mm	5	12	Costa Espalda Back
4	Fronte gaveta Frente cajón Front drawer	592X164X15mm	5	13	Porta Média Puerta média Door
				14	Tampo Grande Tapa grande Big Top
6	Chapéu Pequeno Tapa pequeno Small top	286X385X12mm	2	15	Costa Lateral Revés lateral Back
7	Lateral esquerda Lateral izquierda Side left	1000X385X12mm	1	16	Tampo Tap Top
8	Lateral direita Lateral derecha Side right	1000X385X12mm	1	17	Travessa Travessia Dash
9	Rodapé frontal Rodapié frontal Front baseboard	883X75X15mm	1		

**2º 2º Passo**  
**2th Step**  
**Paso 2**

**RODIAL**  
www.rodial.com.br

**1º 1º Passo**  
**1th Step**  
**Paso 1**