

ASSEMBLY INSTRUCTIONS MANUAL DE MONTAGEM / INSTRUCCIONES DE ARMADO

PEROLA WARDROBE 4 DOORS
GUARDA ROUPA PEROLA 4 PORTAS
ROPERO PEROLA 4 PUERTAS

Reference
Referência
Referencia

250298

Revise
Revisão
Revisión

00

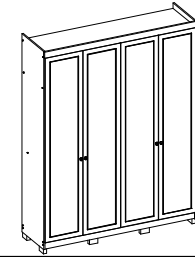

YOU WILL NEED VOCÊ VAI PRECISAR DE / USTED NECESITARÁ

Tools not supplied
Ferramentas não fornecidas / Herramientas no incluidas

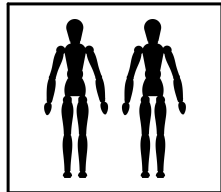

2 People
2 Pessoas
2 Personas

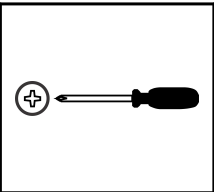

Screwdriver Phillips
Chave Phillips
Destornillador cruz

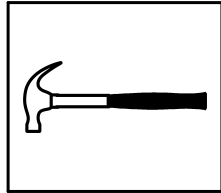

Hammer
Martelo
Martillo

PARTS IDENTIFICATION IDENTIFICAÇÃO DAS PEÇAS / IDENTIFICACIÓN DE LAS PIEZAS

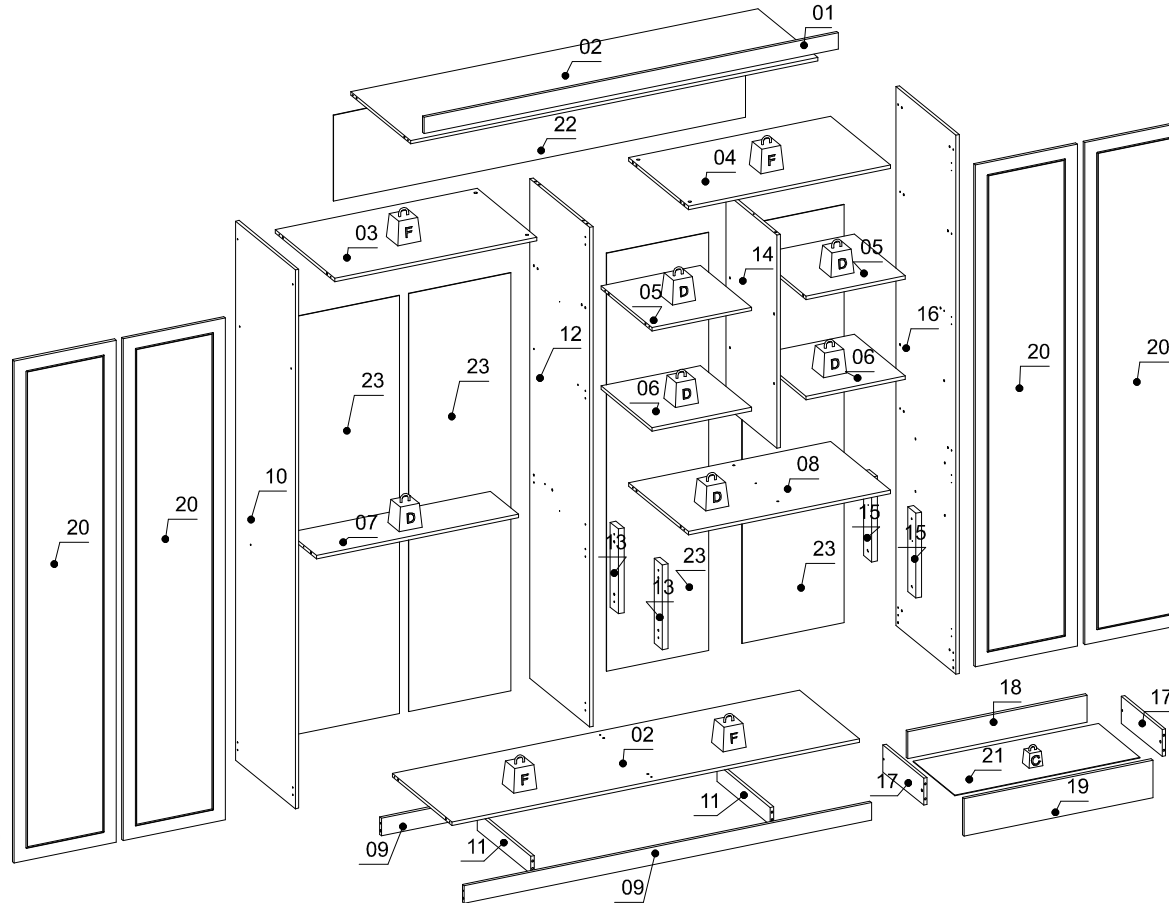

Nº	Measures_Inches	Medidas_cm	Qty./Qtd.
01	71 x 2 3/4 x 5/8	180.3 x 7.0 x 1.5	1
02	69 3/4 x 20 1/2 x 5/8	177.3 x 52.0 x 1.5	2
03	34 5/8 x 20 1/2 x 5/8	87.9 x 52.0 x 1.5	1
04	34 5/8 x 20 1/2 x 5/8	87.9 x 52.0 x 1.5	1
05	17 x 17 1/2 x 5/8	43.2 x 44.5 x 1.5	2
06	17 x 17 1/2 x 5/8	43.2 x 44.5 x 1.5	2
07	34 5/8 x 9 5/8 x 5/8	87.9 x 24.3 x 1.5	1
08	34 5/8 x 20 1/2 x 5/8	87.9 x 52.0 x 1.5	1
09	69 3/4 x 3 x 5/8	177.3 x 7.5 x 1.5	2
10	90 1/2 x 20 1/2 x 5/8	230.0 x 52.0 x 1.5	1
11	18 1/4 x 3 x 5/8	46.5 x 7.5 x 1.5	2
12	83 7/8 x 20 1/2 x 5/8	213.2 x 52.0 x 1.5	1
13	14 1/4 x 2 3/4 x 1	36.2 x 7.0 x 2.5	2
14	35 7/8 x 17 1/2 x 5/8	91.0 x 44.5 x 1.5	1
15	14 1/4 x 2 3/4 x 1	36.2 x 7.0 x 2.5	2
16	90 1/2 x 20 1/2 x 5/8	230.0 x 52.0 x 1.5	1
17	14 x 4 1/2 x 5/8	35.5 x 11.5 x 1.5	4
18	30 3/4 x 4 1/2 x 5/8	78.0 x 11.5 x 1.5	2
19	32 3/8 x 6 1/4 x 5/8	82.1 x 16.0 x 1.5	2
20	84 3/8 x 17 1/2 x 5/8	214.2 x 44.4 x 1.5	4
21	31 3/4 x 14 1/8 x 1/8	80.6 x 36.0 x 0.3	2
22	70 5/8 x 14 1/2 x 1/8	179.3 x 36.7 x 0.3	1
23	70 1/4 x 17 1/2 x 1/8	178.4 x 44.4 x 0.3	4

MAXIMUM RECOMMENDED WEIGHT BEING THIS EVENLY DISTRIBUTED.
PESO MÁXIMO RECOMENDADO SIENDO ESTE DISTRIBUIDO UNIFORMEMENTE.
PESO MÁXIMO RECOMENDADO SIENDO ESTE UNIFORMEMENTE DISTRIBUIDO.

	LB	KG
—		
C	6	3
D	11	5
F	22	10

IDENTIFICATION OF ACCESSORIES IDENTIFICAÇÃO DOS ACESSÓRIOS/ IDENTIFICACIÓN DE ACCESORIOS



The separation of the accessories before you start the assembly will facilitate the same. In case of doubt on the size of the screws and bolts, use the ruler to bottom of page.
 A separação dos acessórios antes de iniciar a montagem facilitará a mesma. Em caso de dúvida no tamanho dos parafusos e cavilhas, utilize a régua ao final da página.
 La separación de los accesorios antes de comenzar el armado facilitará el mismo. En caso de duda sobre el tamaño de los tornillos y taquetes, utilice la regla al pie de página.

A3		Trapeze Trapézió / Trapecio	-	4
A4		Metalic bracket Cantoneira de metal / Soporte de metal	22x22 mm	2
A6		"H" profile Perfil "H" / Perfil "H"	-	2
B5		Metalic angle plates Cantoneira de metal / Soporte de metal	46 mm	4
C1		Metal claw Garra de metal / Garra metal	-	17
C26		Foot Pé Atenas / Pie	55x40x100mm	8
D		Flat head screw Parafuso chato / Tornillo de cabeza plana	4,0x40 mm	4
E		Wooden dowel Cavilha / Taquete	8x30 mm	52
E3		Shelf bracket Suporte de prateleira / Soporte de repisa	8x7 mm	8
F		Wooden dowel Cavilha / Taquete	8x50 mm	4
G		Structural screw Parafuso estrutural / Tornillo estructural	5,0x50	28
H		Allen key Chave allen / Liave allen	3 mm	2
H27		Handle Puxador Italia / Tirador	-	4
I		Structural screw cover Tampa parafuso estrutural / Tapa tornillo estructural	-	26
J		Simple minifix screw Haste minifix simples / Tornillo minifix simple	-	4
K		Double minifix screw Haste minifix dupla / Tornillo minifix doble	60mm	2
L		Drum lock Tambor minifix / Tambor minifix	12 mm	8
L9		Flat head screw Parafuso chato / Tornillo de cabeza plana	3,5x12 mm	28
L17		Telescopic slide Corrediça telescópica / Corredera telescópica	350 mm	4
M		Bora patch adhesive Tapa furo adesivo / Tapones adhesivo	-	8
M2		Nut Porca / Tuerca	4 mm	8
N		Nail Prego / Clavo	10x10	140
N7		Wooden dowel Cavilha / Taquete	8x20 mm	8
o5		Flanged head screw Parafuso flangeado / Tornillo de cabeza flangeada	3,5x14 mm	24

P		Pan head screw Parafuso panela / Tornillo de pan	4,5x25 mm	4
Q3		Clothes rack Cabideiro tubo / Perchero	-	2
Q9		Clothes rack support Suporte cabideiro / Soporte perchero	-	4
S		Pan head screw Parafuso panela / Tornillo de pan	3,5x14 mm	100
T		Flanged head screw Parafuso flangeado / Tornillo de cabeza flangeada	3,5x25 mm	4
T8		Flat head screw Parafuso chato / Tornillo de cabeza plana	3,5X35 mm	8
U5		Flat head screw Flat head screw / Flat head screw	4,0X25 mm	8
Z15		Metal hinge curve Dobradiça curva / Esquina de bisagra metálica	35 mm	16

SEPARATE THE TWO PARTS OF THE METAL SLIDE TO THE ASSEMBLY FOLLOWING THE INSTRUCTIONS BELOW.
 SEPARAR AS DUAS PARTES DA CORREDIÇA METÁLICA PARA A MONTAGEM SEGUINDO AS INSTRUÇÕES ABAIXO.
 SEPARAR LAS DOS PARTES DE LA CORREDERA DE METAL PARA EL ARMADO Y SEGUIR LAS INSTRUCCIONES ABAJO.

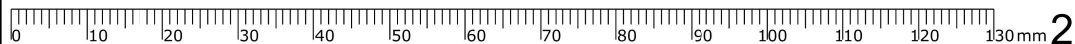
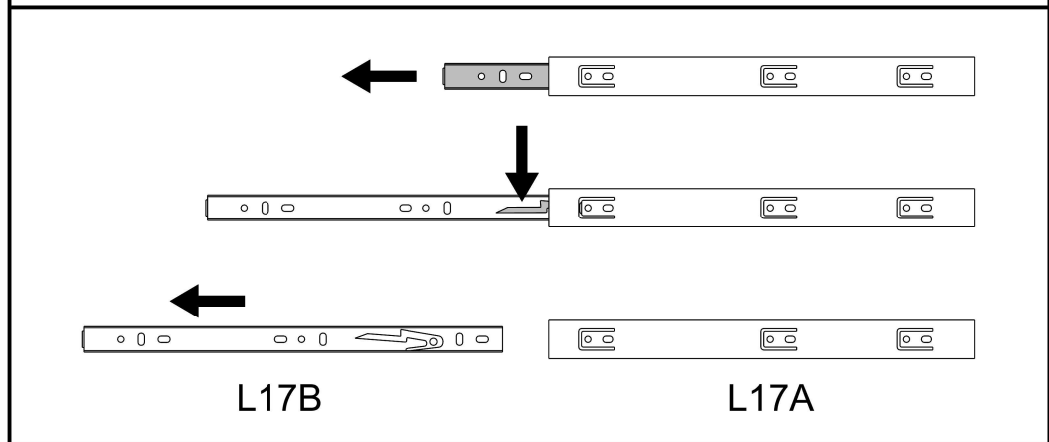

**PRE-ASSEMBLE
PRÉ-MONTAGEM / PRE ARMADO**

01

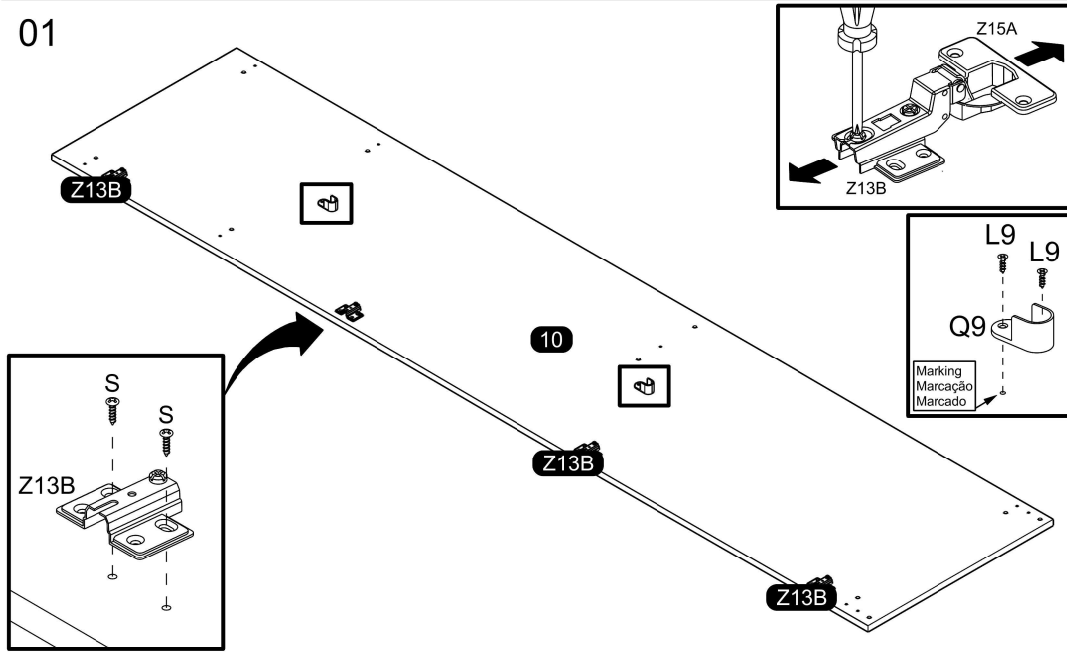

03

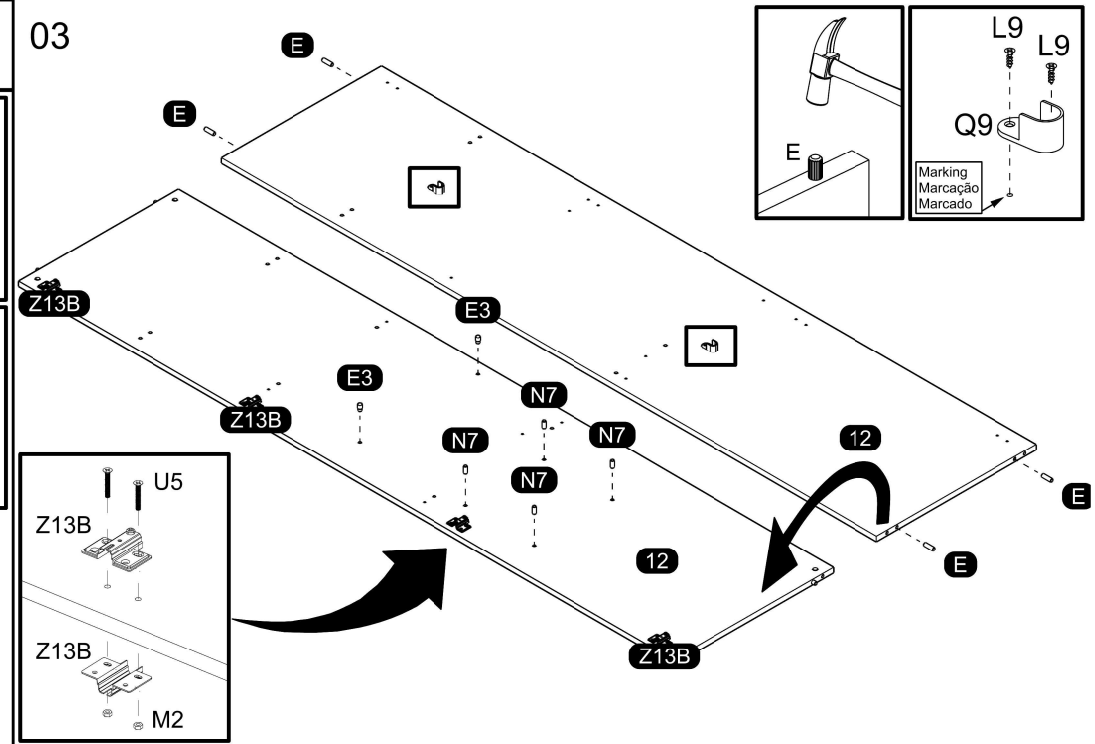

02

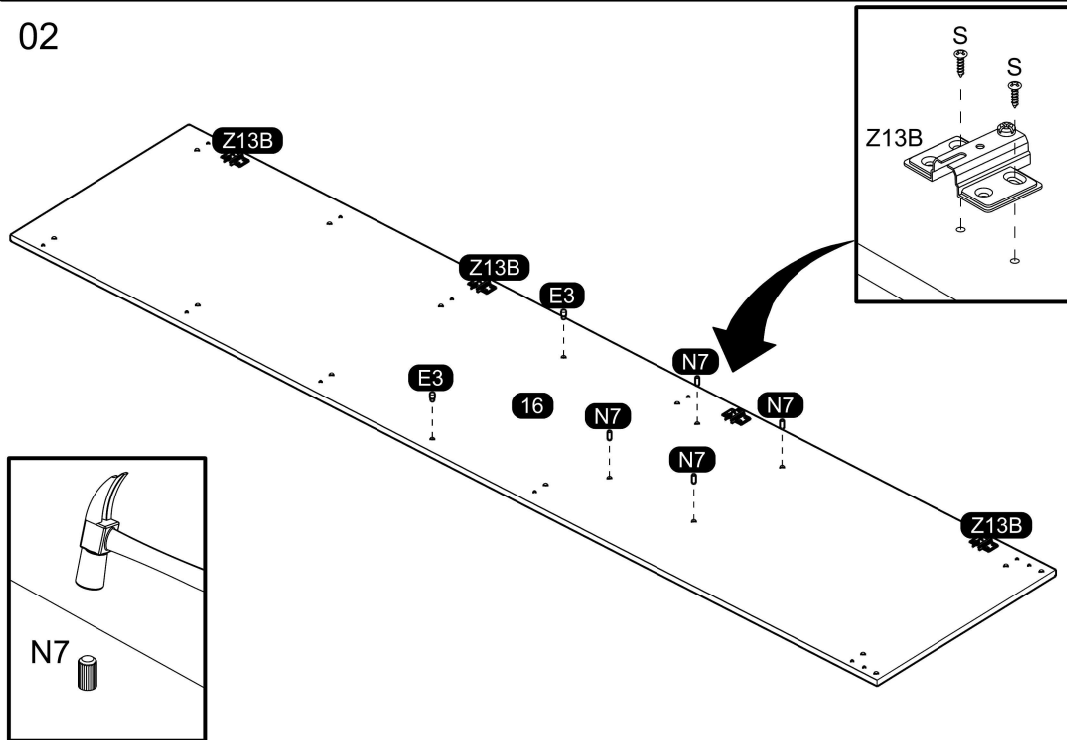

04

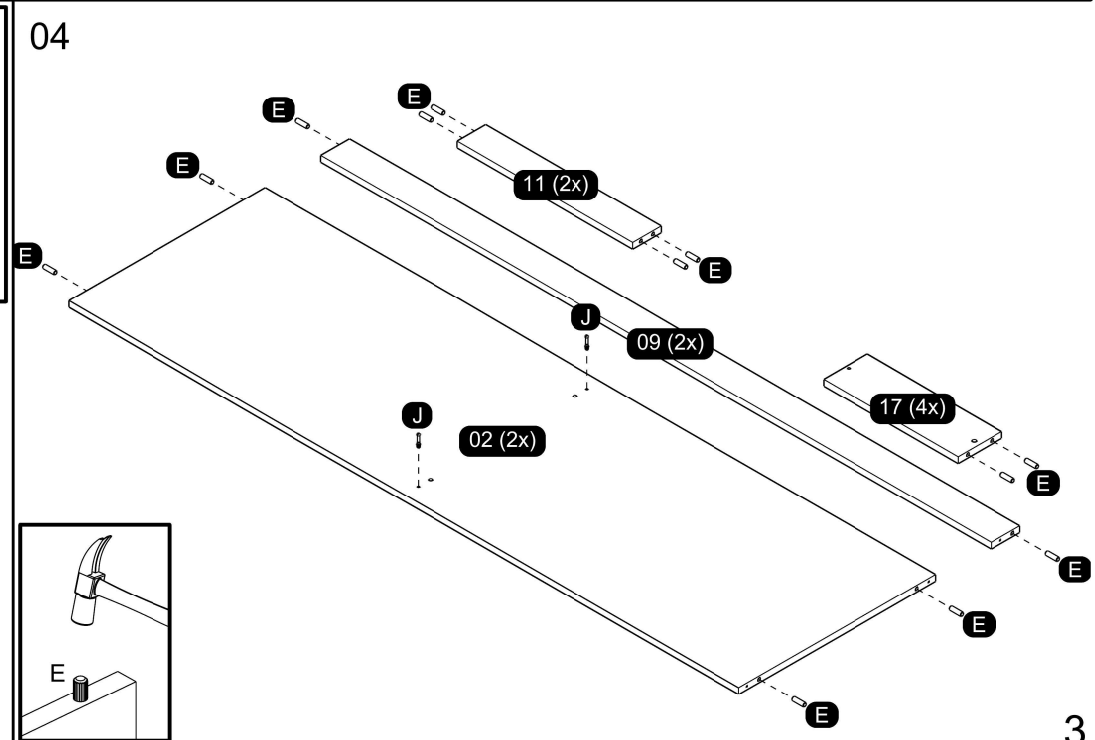

05

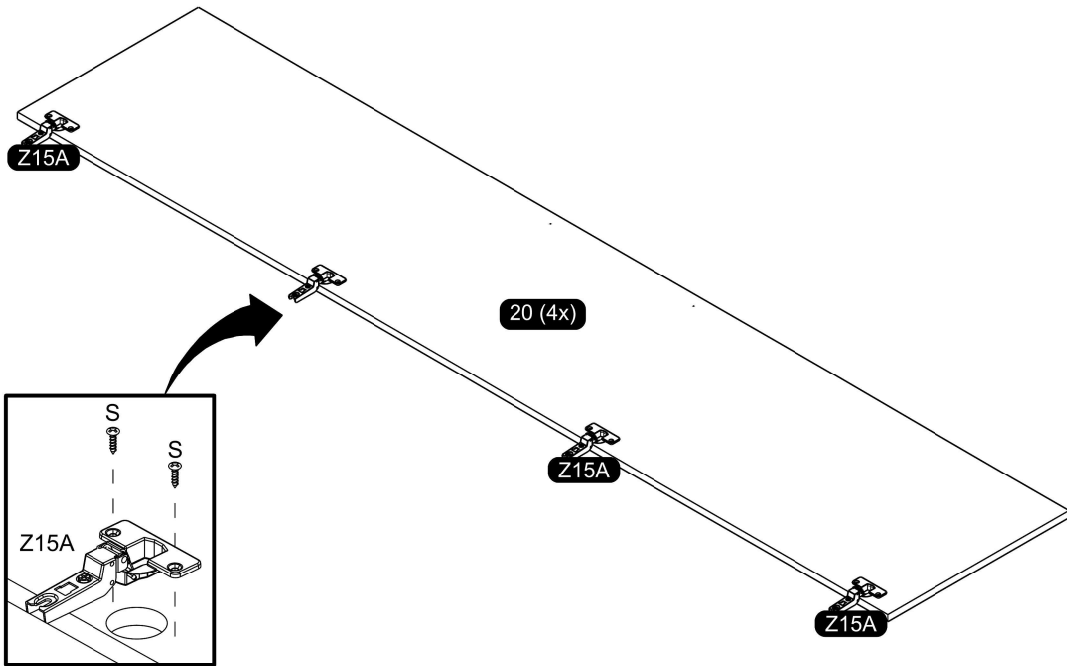

07

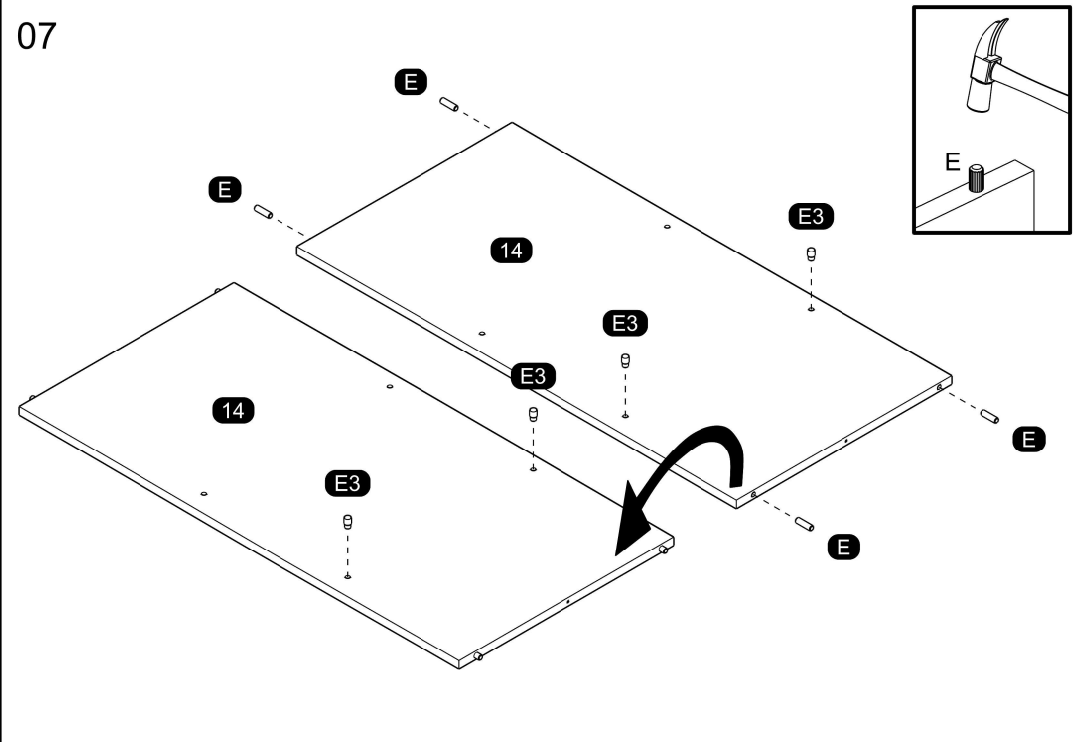

06

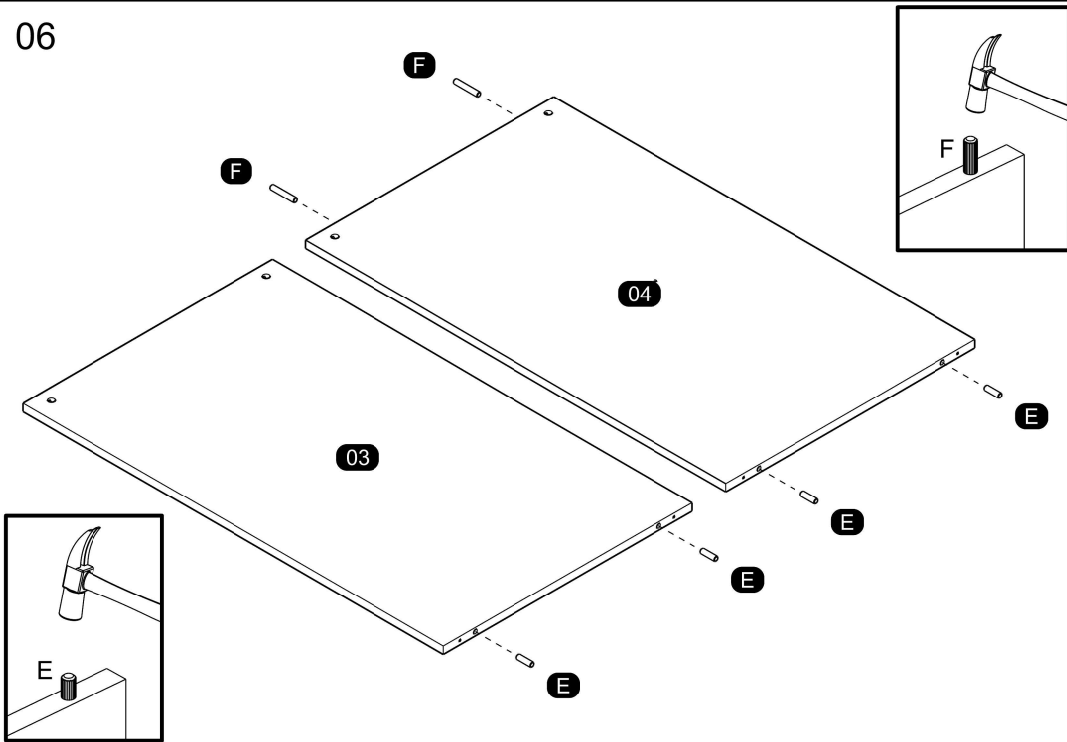

08

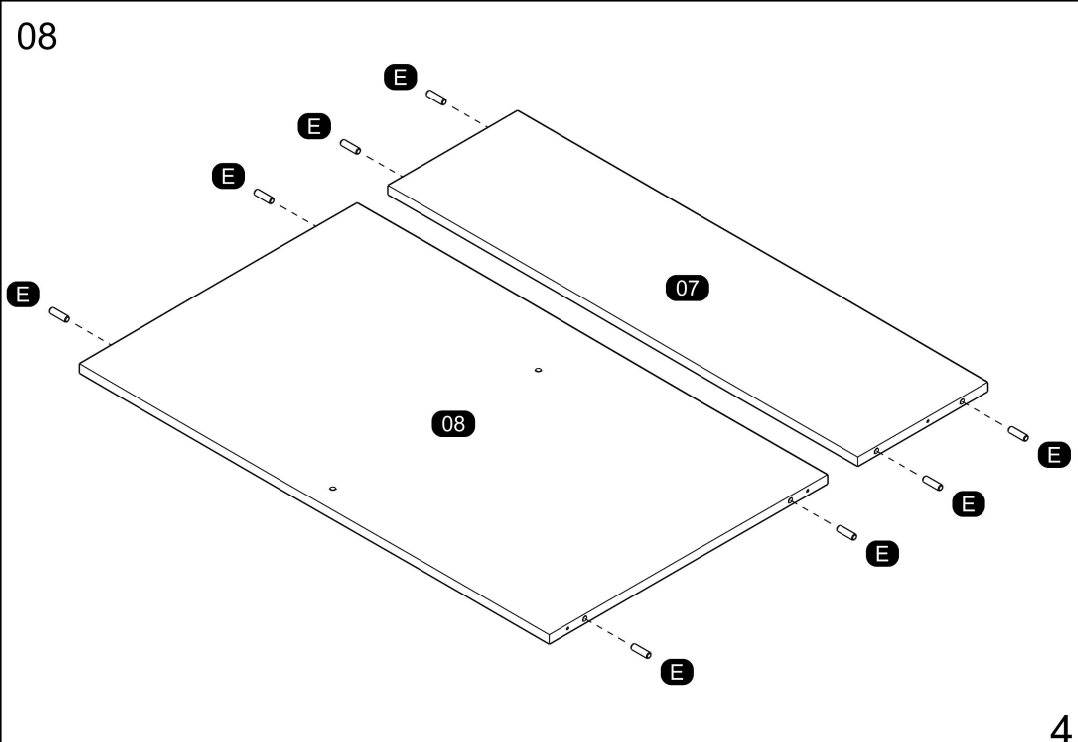

09

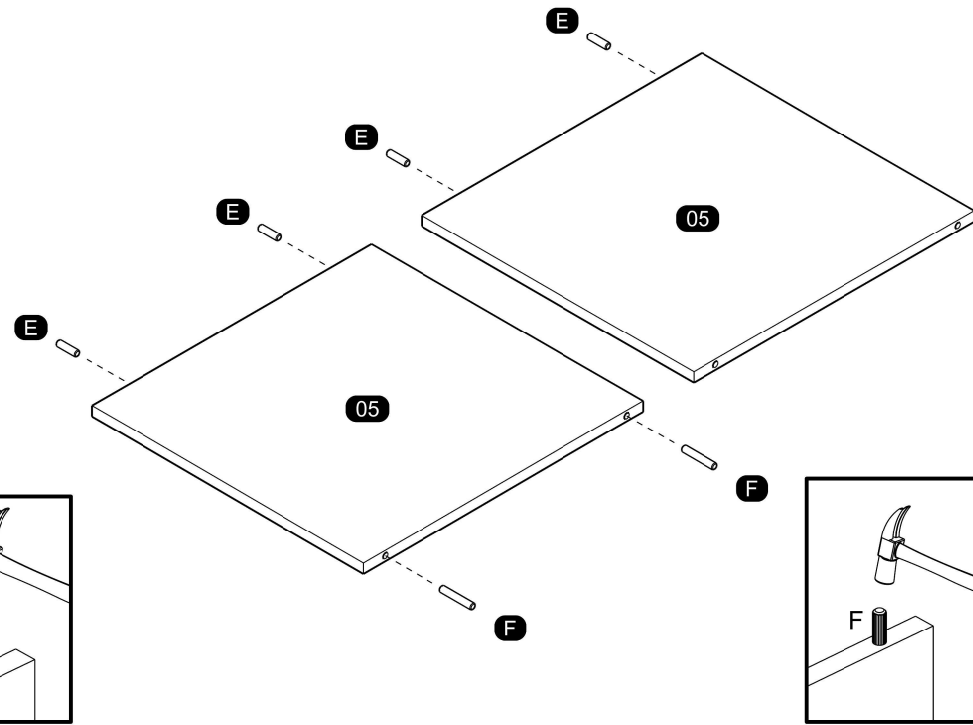

11

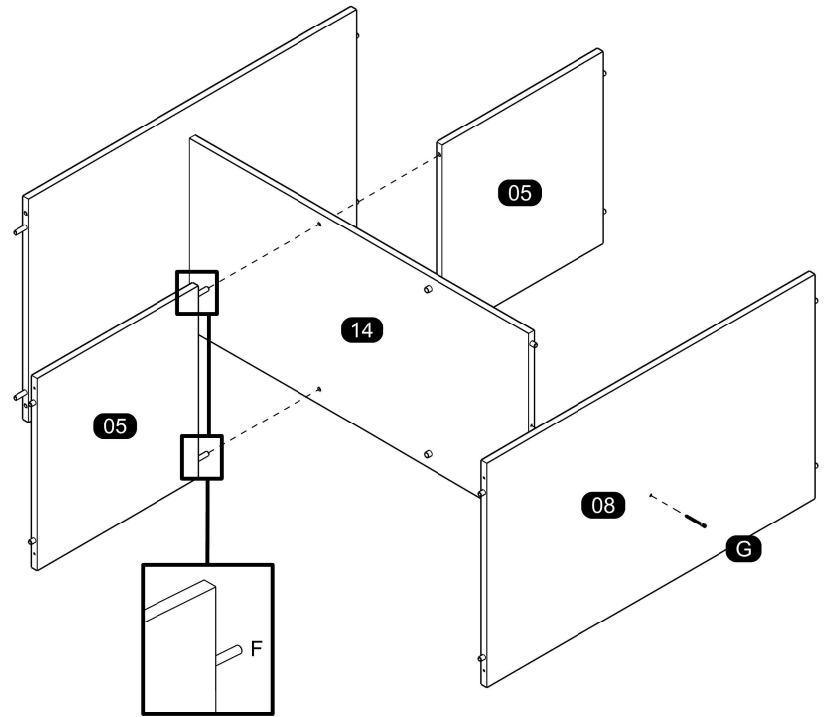

**ASSEMBLY
MONTAGEM / ARMADO**

10

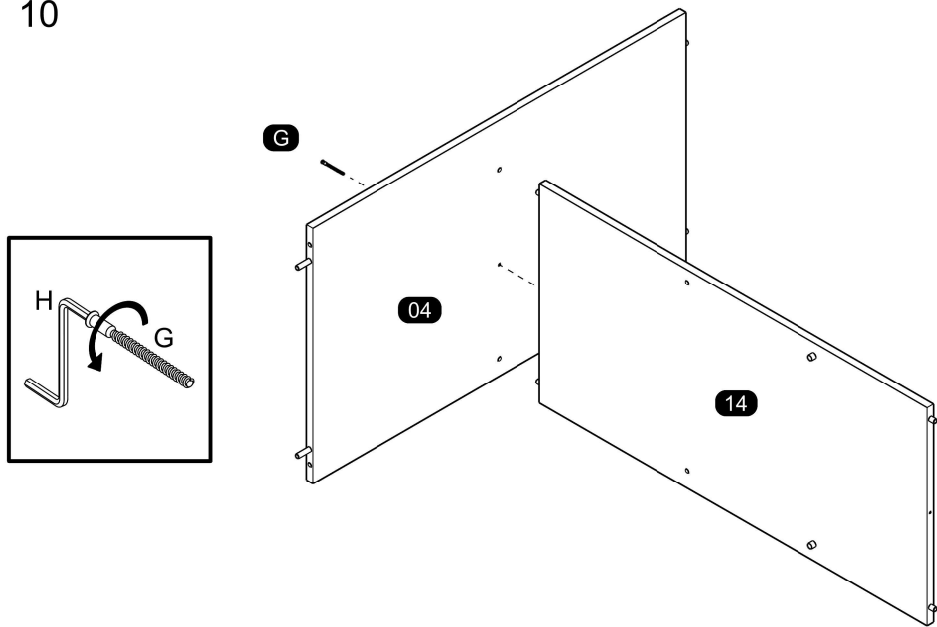

12

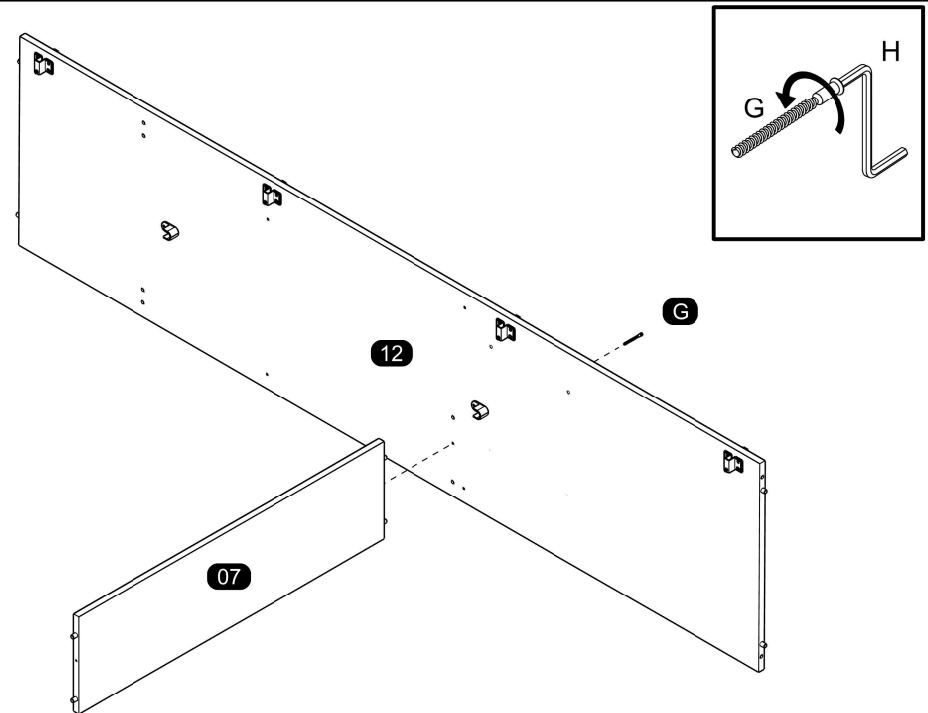

13

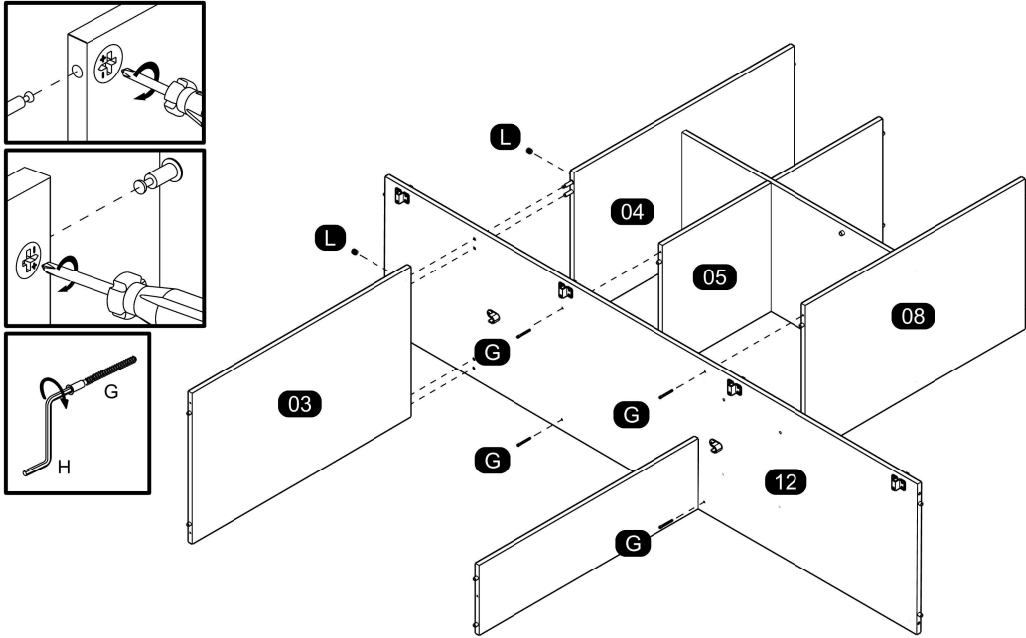

15

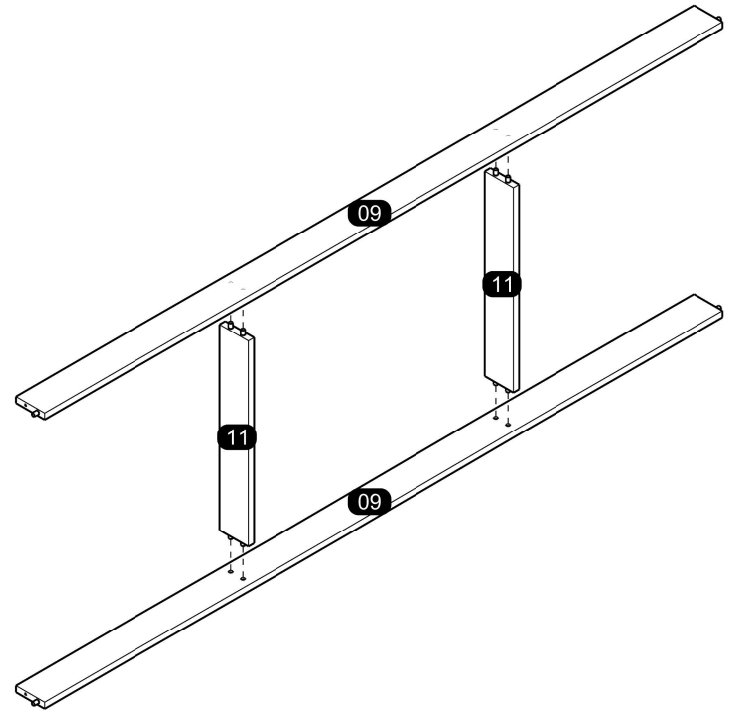

14

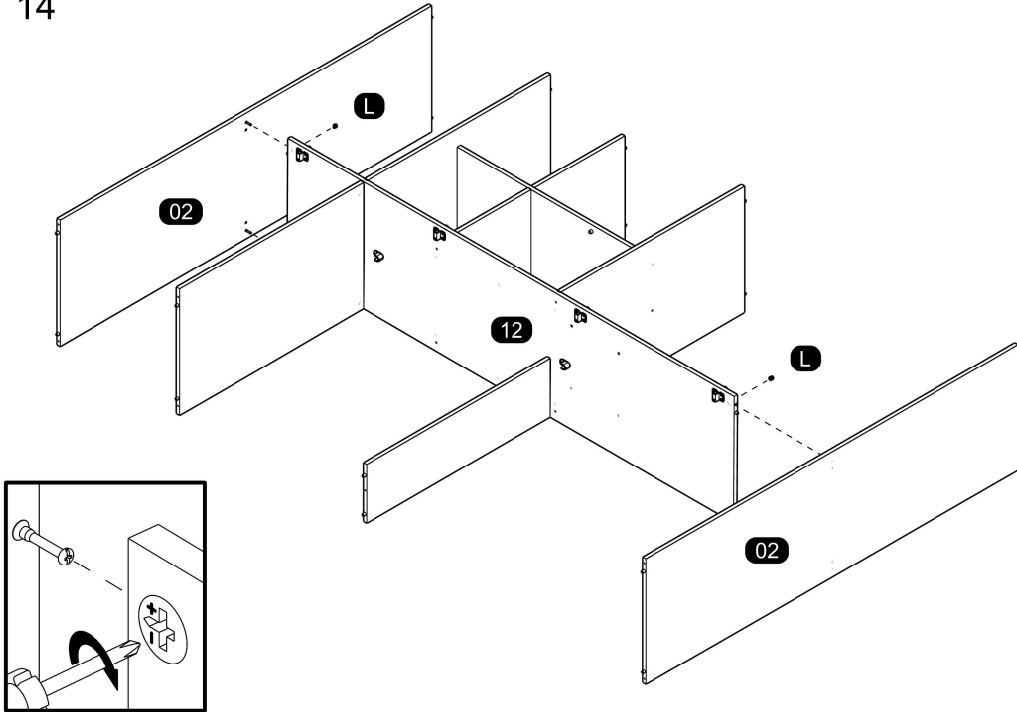

16

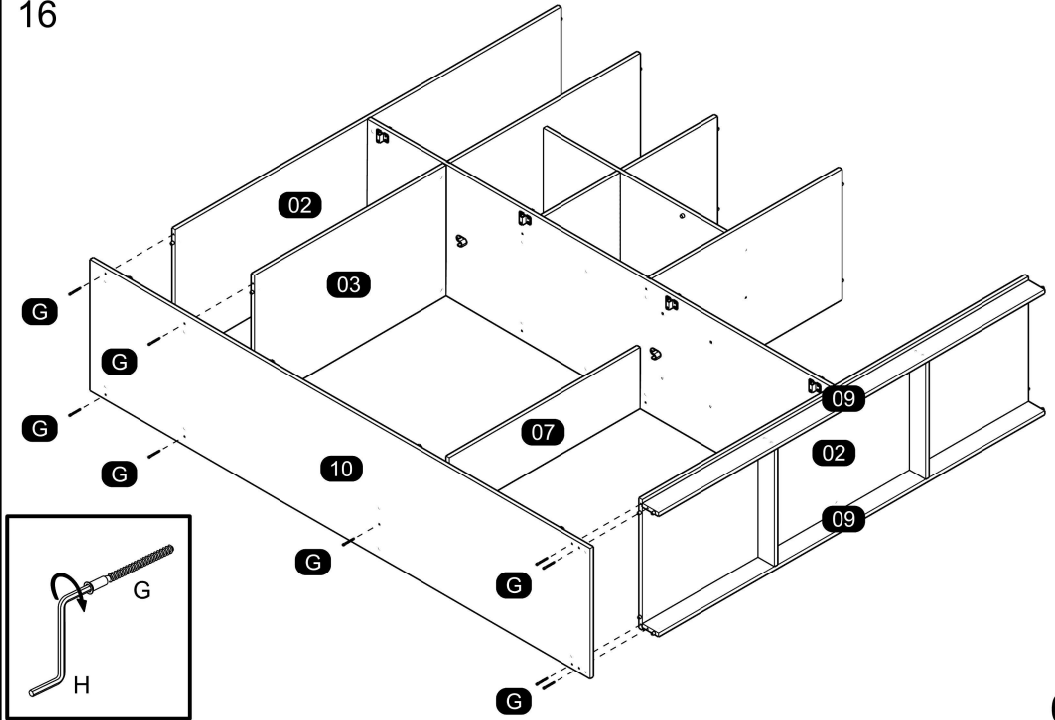

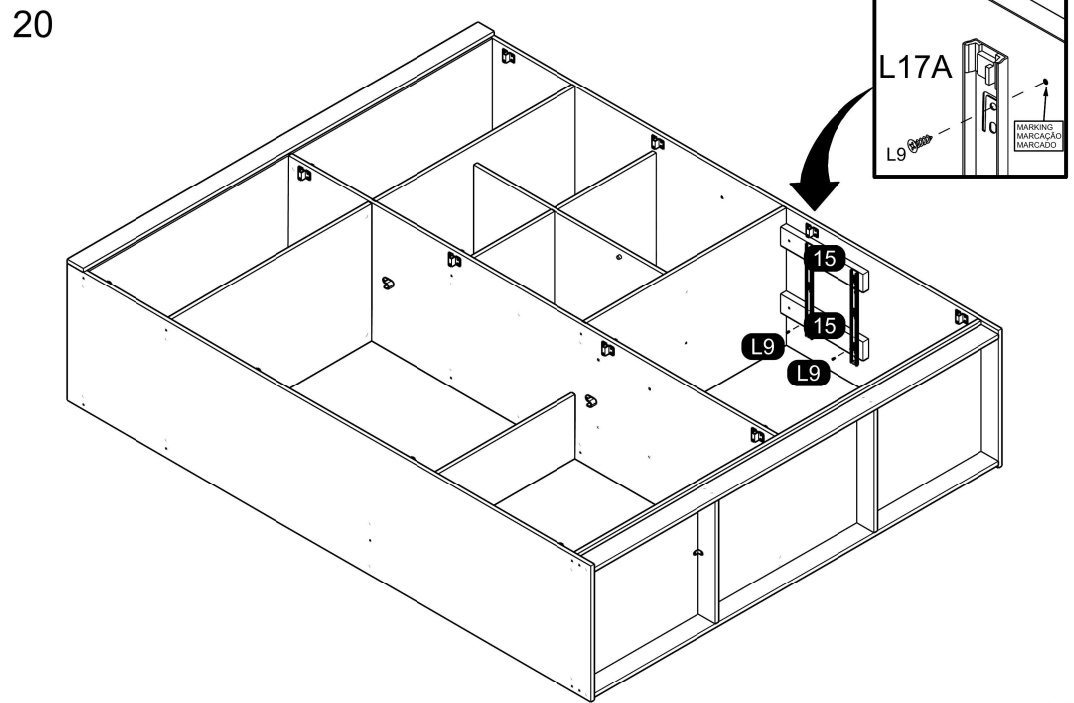
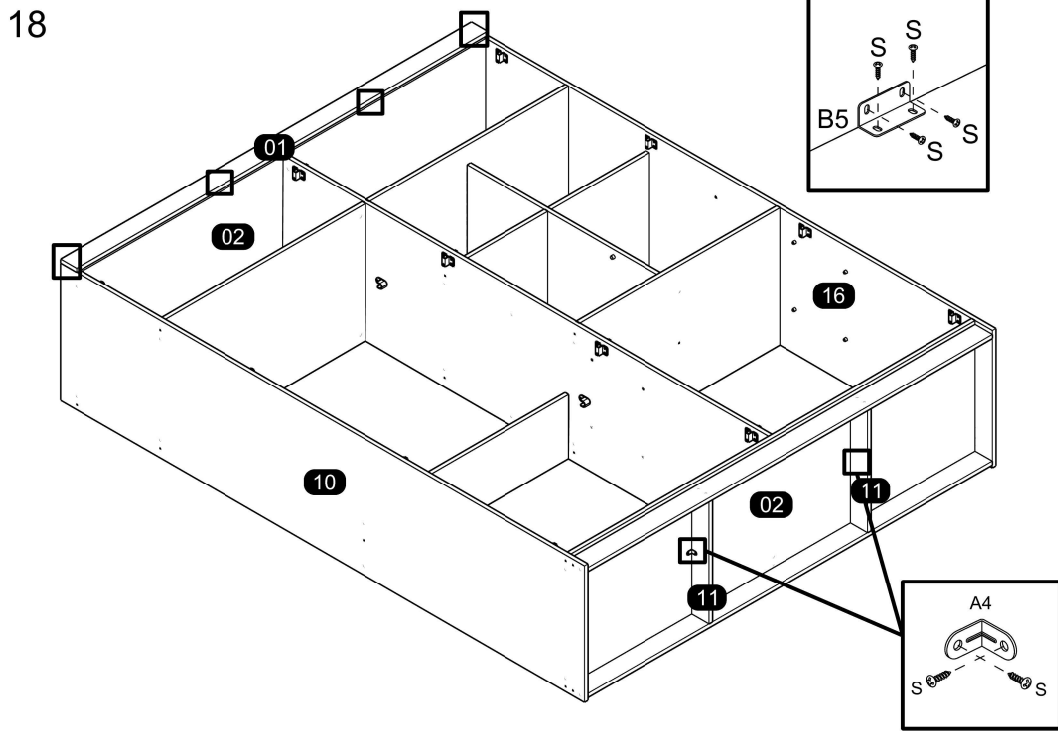
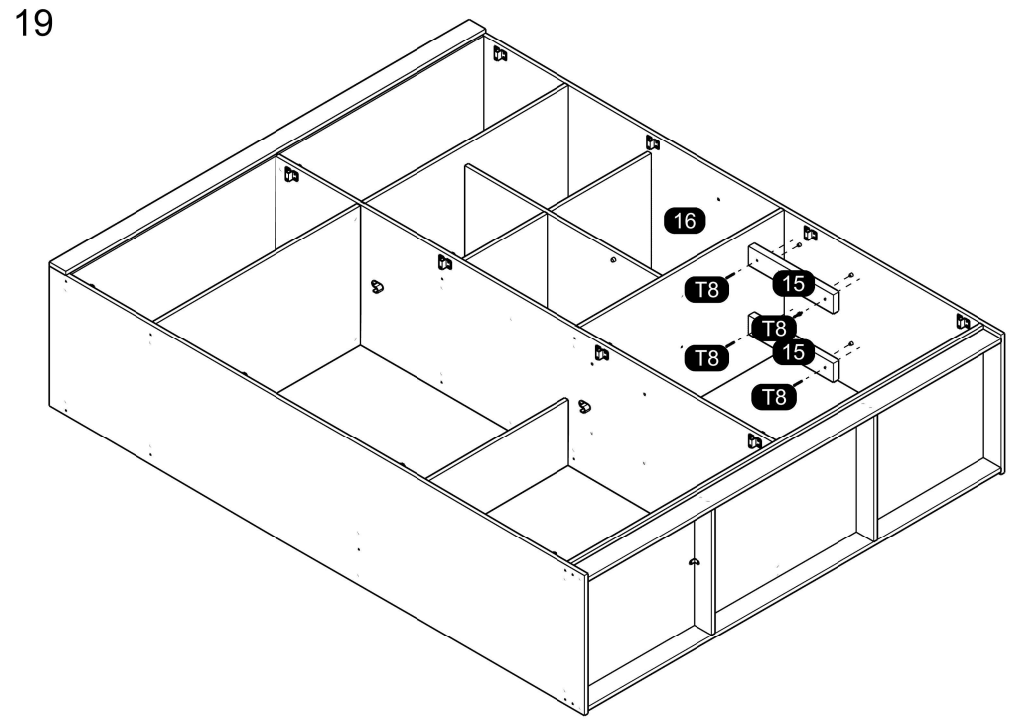
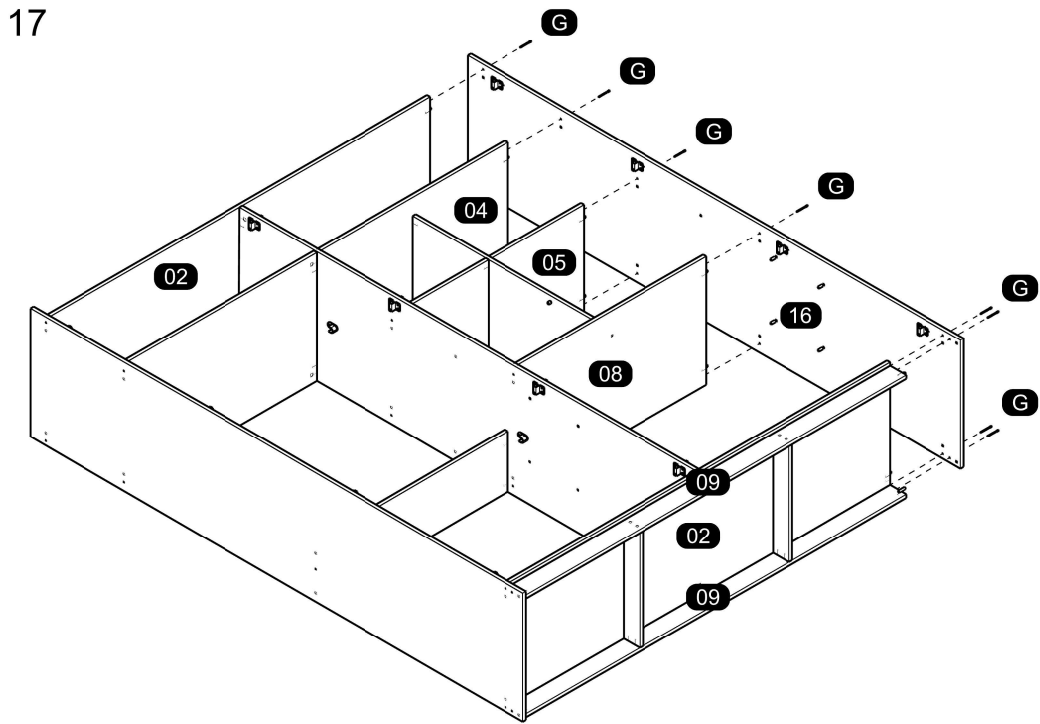

21

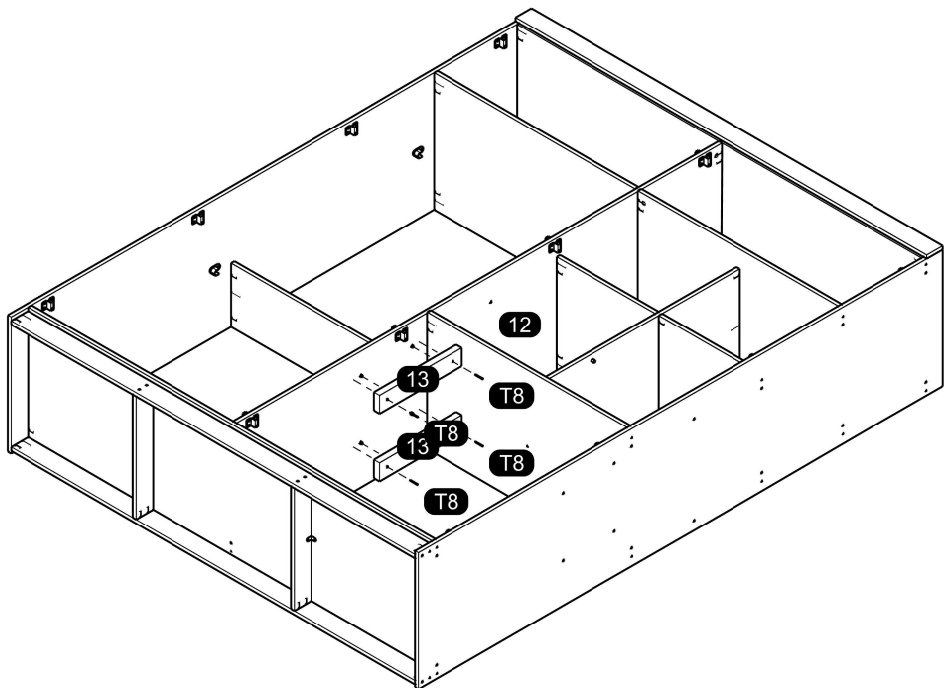

23

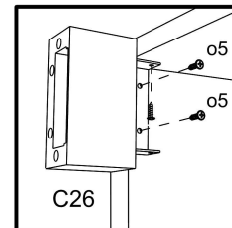
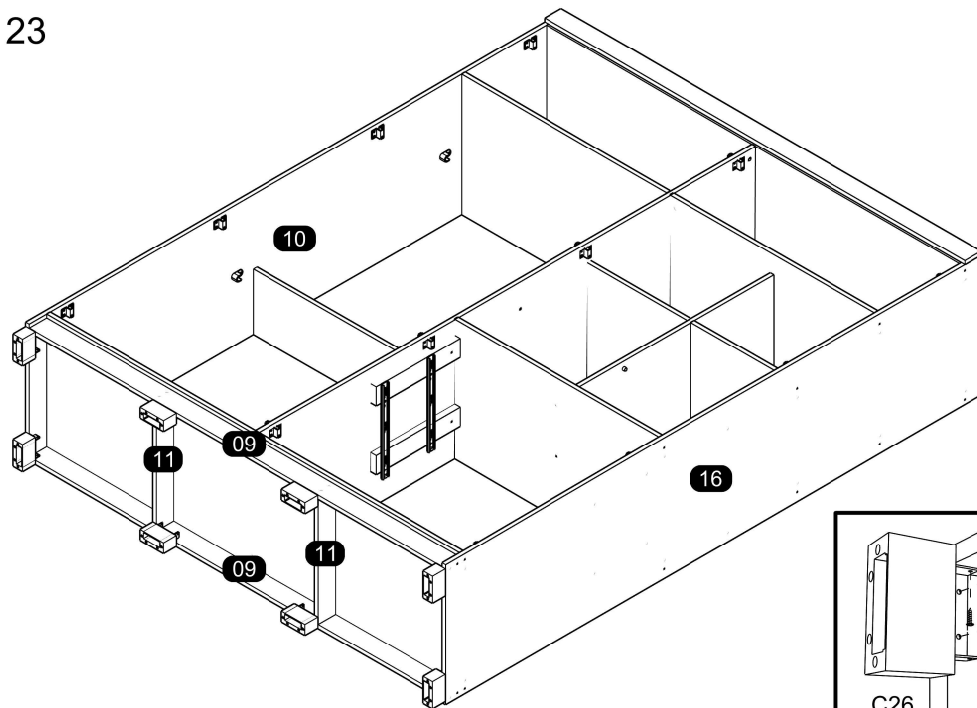

22

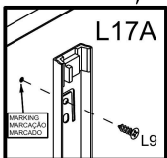
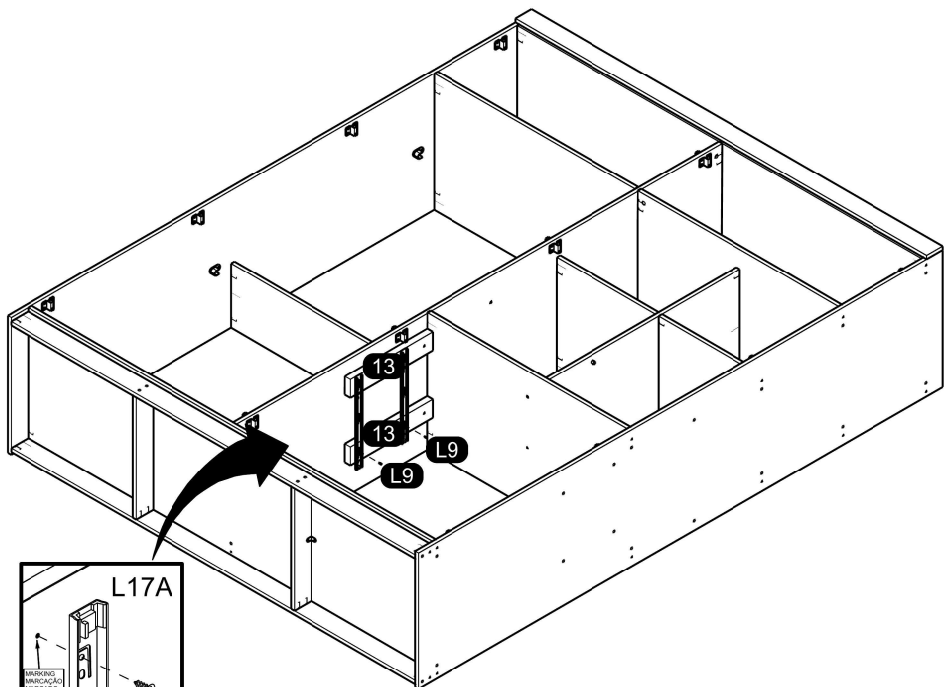

24

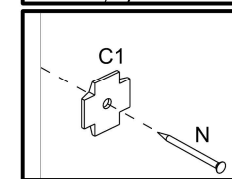
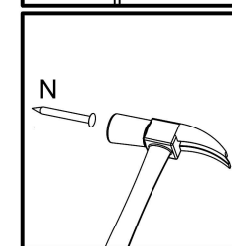
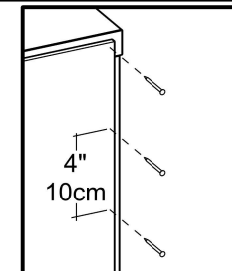
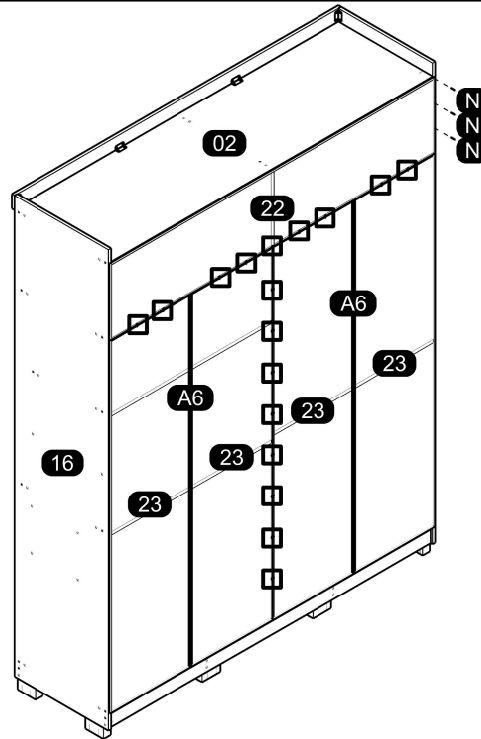

25

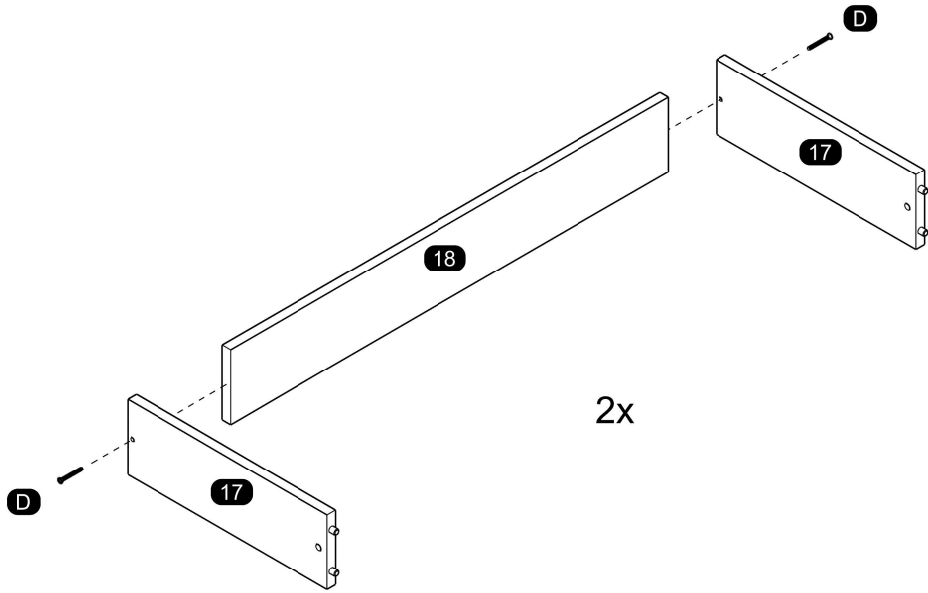

27

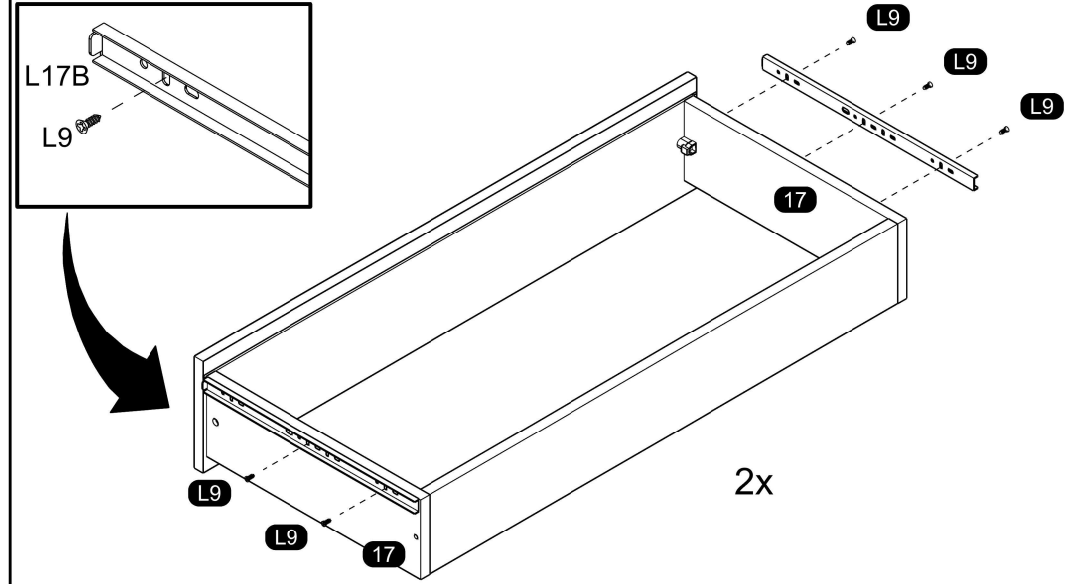

26

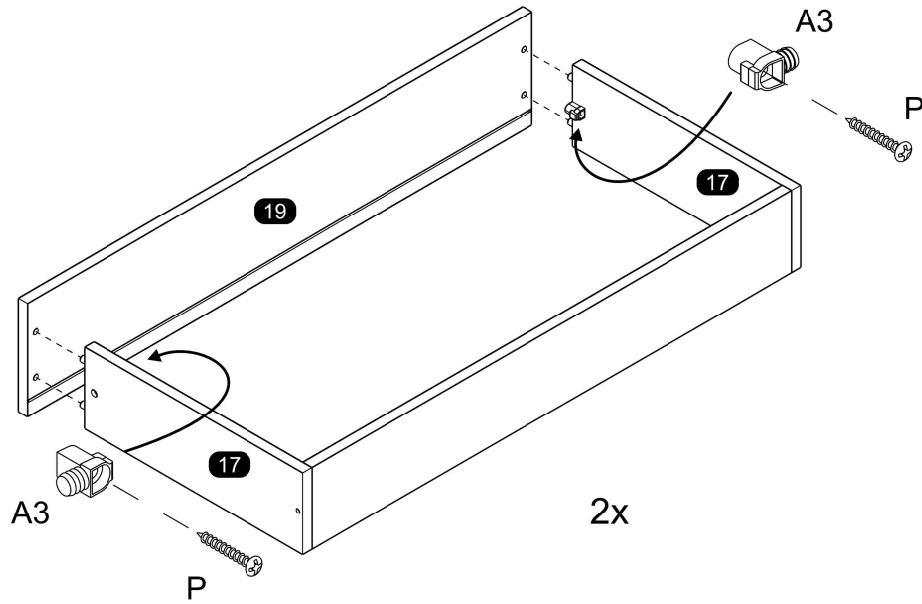

28

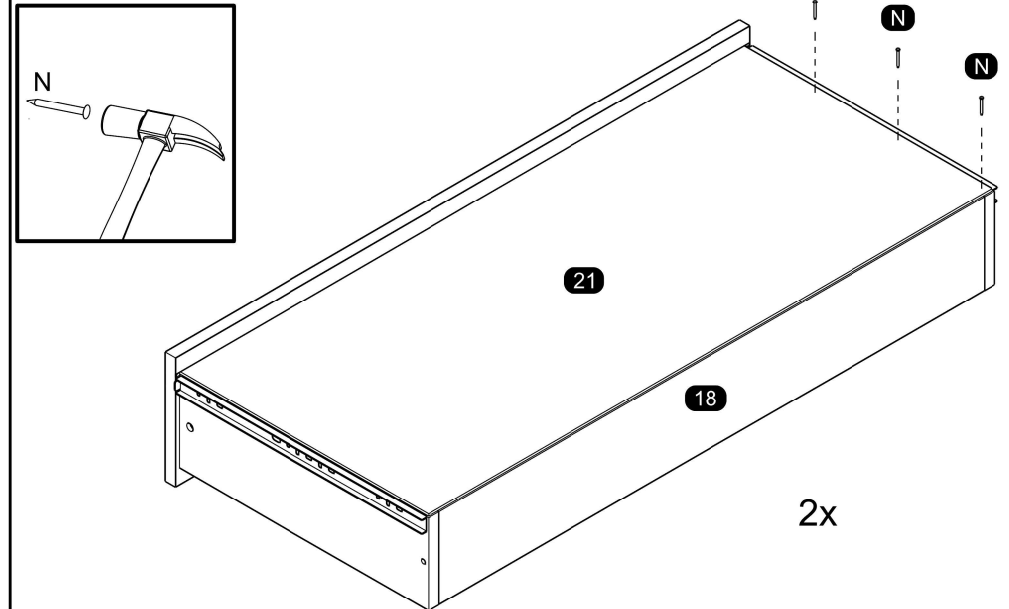

29

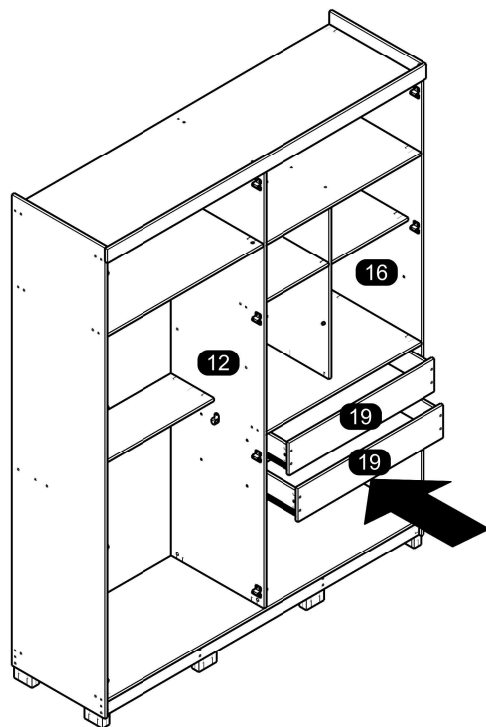

Drawer insertion
 Inserção de gaveta
 Inserción del cajón

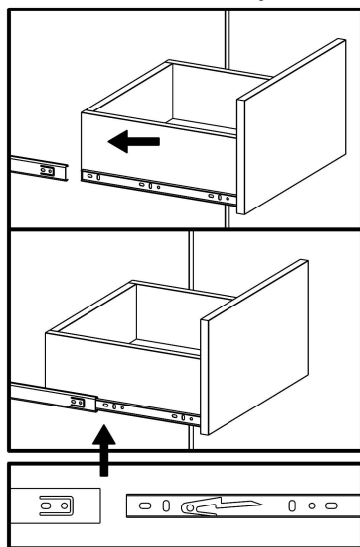

31

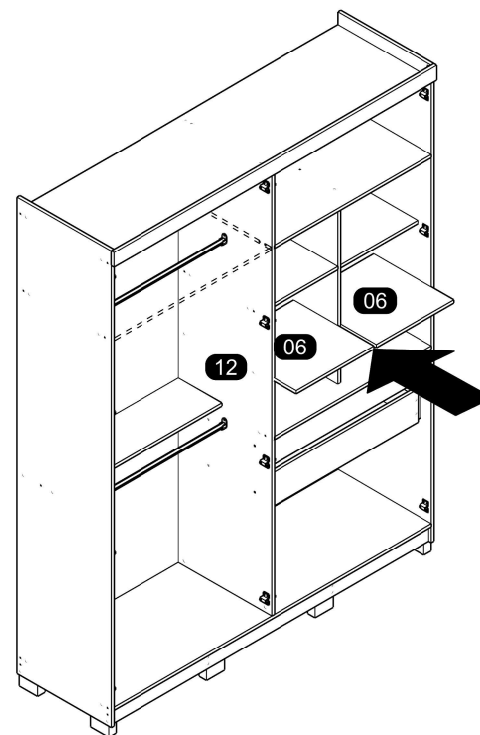

30

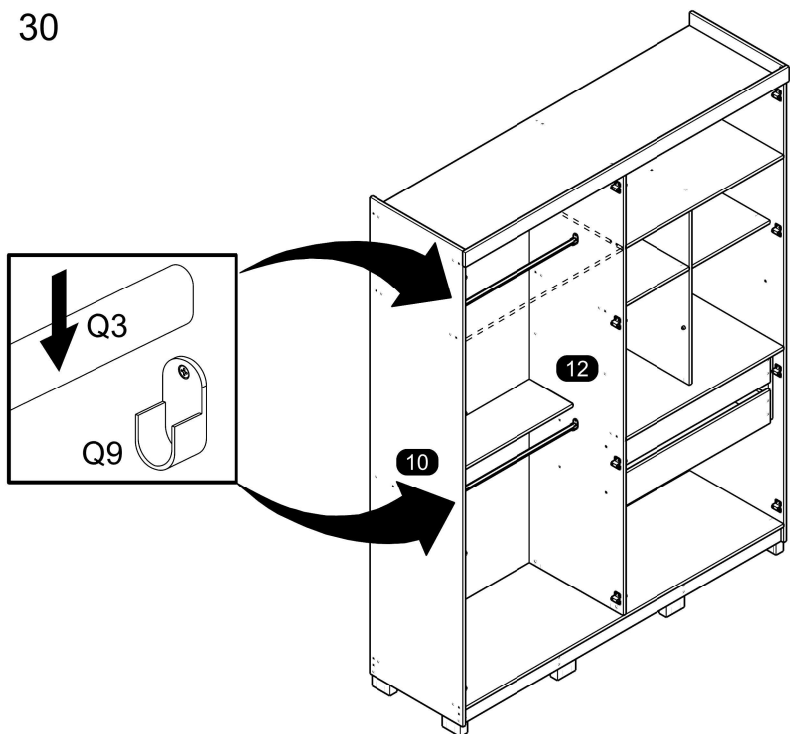

32

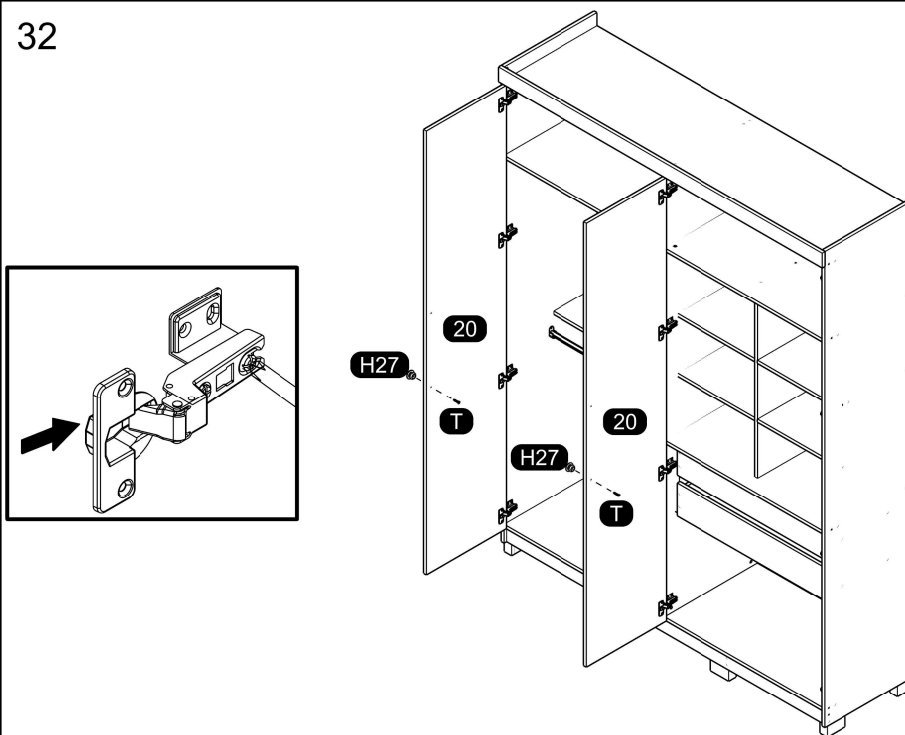

33

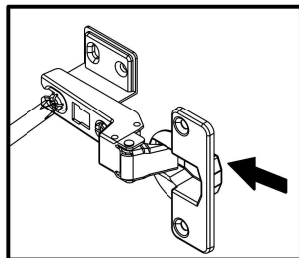
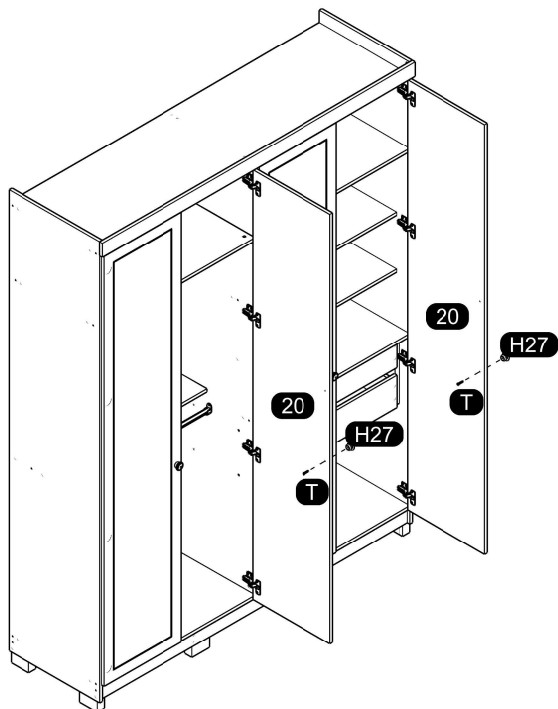

35

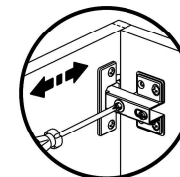
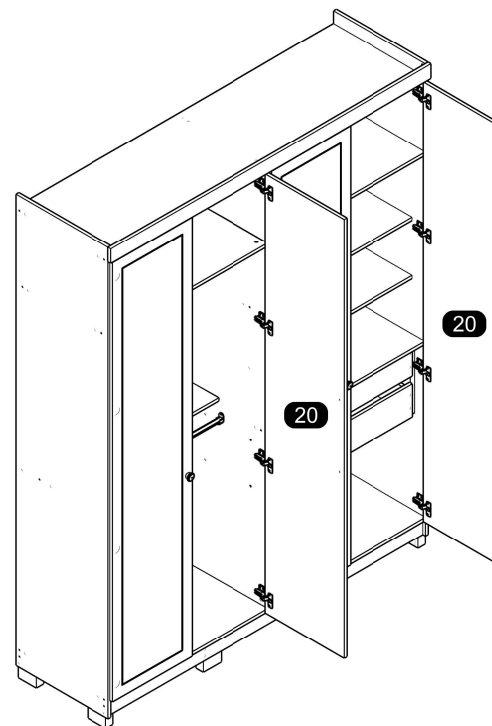

Horizontal Adjustment
Regulagem Horizontal
Ajuste Horizontal

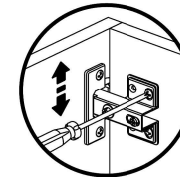

Vertical Adjustment
Regulagem Vertical
Ajuste Vertical

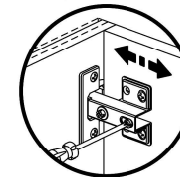

Depth Adjustment
Regulagem Profundidade
Ajuste Profundidad

34

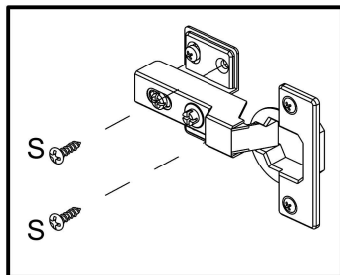
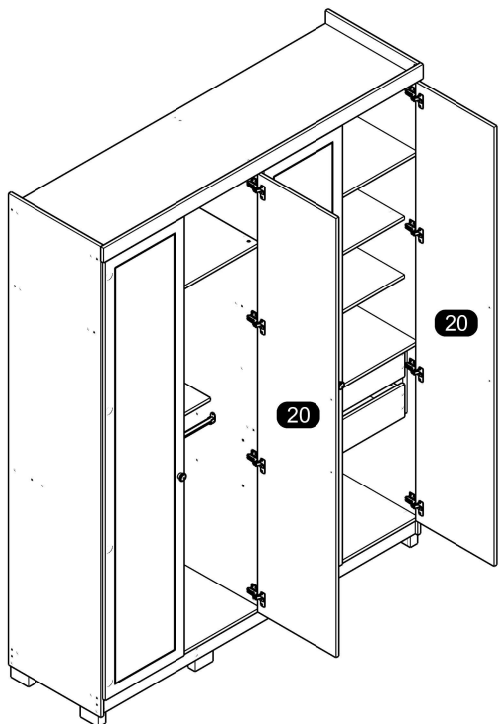

36

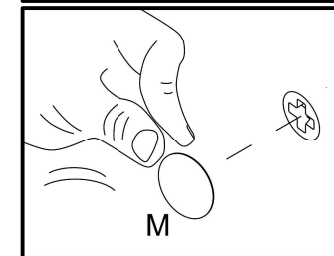
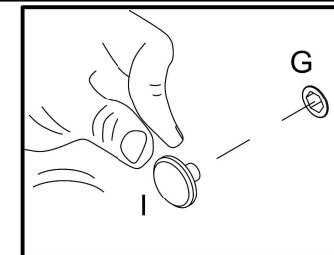
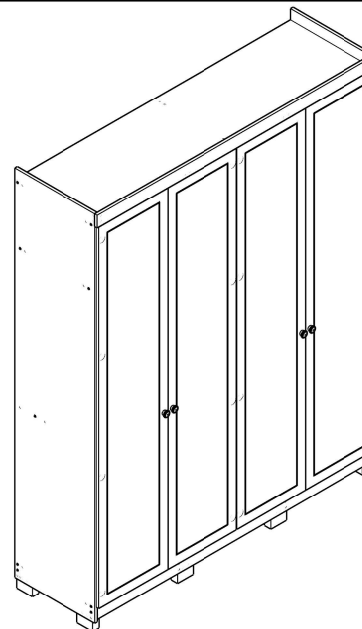

At the end of the assembly, insert the screw cover / hole plugs in the apparent holes.
Ao final da montagem, insira a(s) tampa(s) de parafuso / tapa furos nos furos que ficarem aparentes.
Al final del conjunto, coloque la tapa tornillo / tapón plástico en los agujeros que se hagan evidentes.