

GARANTIA E INSTRUÇÕES DE LIMPEZA E CONSERVAÇÃO

GARANTÍA E INSTRUCCIONES DE LIMPIEZA Y MANTENIMIENTO / WARRANTY AND CLEANING AND CARE INSTRUCTIONS

Nosso produtos são garantidos por 90 dias contra defeitos de fabricação. Ao constatar um problema coberto pela garantia, entre em contato com a loja onde o produto foi comprado. Ela estará capacitada para atendê-lo da melhor forma diante de cada caso. Reclamações de garantia somente poderão ser atendidas se o termo de garantia for apresentado no ato de reivindicação, acompanhado de sua nota fiscal de compra.

Nuestros productos están garantidos contra defectos de fabricación por 90 días, a partir de la compra. Ao constatar un problema protegido por la garantía, póngase en contacto con la tienda donde se adquirió el producto. Ella estará capacitada para atenderlo de la mejor manera de acuerdo con cada caso.

Our products are guaranteed against manufacturing defects for 90 days from the date of purchase. When you find a problem covered by the warranty, please contact the store where the product was purchased. The store be able to serve you in the best way in each case.

Exclusões:

Desgaste natural ou danos causados por água, maresia, ferrugem, incêndio, calor, cupins e pragas em geral. Montagem, manutenção e uso inadequado. Não cumprimento das recomendações técnicas do esquema. Montagens e desmontagens após a primeira instalação. Instalações elétricas e outras afins.

Exclusões:

Desgaste natural o daños causados por agua, niebla salina, óxido, fuego, calor, termitas y plagas en general. Mantenimiento y uso inadecuado. Incumplimiento de las recomendaciones técnicas del esquema. Montaje y desmontaje tras la primera instalación. Instalaciones eléctricas y otras similares.

Exclusões:

Natural wear and tear or damage caused by water, sea spray, rust, fire, heat, termites and pests in general. Improper assembly, maintenance and use. Failure to comply with the technical recommendations of the scheme. Assembly and disassembly after the first installation. Electrical and other related installations.

Para retirar o pó, utilize um pano seco, espanador ou aspirador. Se necessário, para uma limpeza mais efetiva, utilize um pano levemente umedecido com água. Finalize com uma flanela limpa e seca. Evite materiais abrasivos, umidade e calor.

Importante

A Linea Brasil não autoriza nenhuma pessoa, loja ou entidade assumir em seu nome qualquer outra garantia que não conste no certificado. A fabricante reserva-se no direito de efetuar nos produtos eventuais modificações que considerar necessárias, sem prejudicar as características essenciais. Os produtos terão peças de assistência para reposição no período de 1 ano a contar de sua retirada do mercado, desde que haja matéria-prima equivalente, observando o dispositivo no Art.32 da Lei 8.078/90 (Cód. Defesa do Consumidor). O atendimento para produtos fora de linha é feito por programação especial, através da loja revendedora sob aprovação de consulta prévia ao fabricante.

Importante

Linea Brasil no autoriza a ninguna persona, tienda o entidad a asumir en su nombre cualquier otra garantía que no figure en el certificado. El fabricante se reserva el derecho de efectuar en los productos eventuales modificaciones que considere necesarias, sin perjudicar las características esenciales. Los productos tendrán piezas de asistencia para reposición en el período de 1 año a partir de su retirada del mercado. La atención para productos fuera de línea es hecha por programación especial, a través de la tienda revendedora bajo aprobación de consulta previa al fabricante.

Importante

Linea Brasil does not authorize any person, store or entity to assume on its behalf any other warranty that does not appear on the certificate. The manufacturer reserves the right to make in the products any modifications that it considers necessary without prejudice to the essential characteristics. The products will have replacement parts within one year of being withdrawn from the market. The service for off-line products is done by special programming, through the store reseller under prior consultation with the manufacture.

Para quitar el polvo, utilice un paño seco, un plumero o una aspiradora. Si es necesario, para una limpieza más eficaz, utilice un paño ligeramente humedecido con agua. Termine con una flanela limpia y seca. Evite materiales abrasivos, humedad y calor.

VOLUME	ITEM	PEÇA	DESCRIÇÃO	DIMENSÕES (mm)		QUANTIDADE	
Caja	Artículo	Pieza	Descripción	Dimensión		Cantidad	Material
BOX	Item	Part	Description	Dimension		Amount	
1	1	510486001	TAMPO INFERIOR PARTE INFERIOR SUPERIOR LOWER TOP	1565	350	12	1 MDP
1	2	510486002	DIVISAO INFERIOR DIVISION INFERIOR LOWER DIVISION	348	279	12	1 MDP
1	3	510486003	BASE BASE BASE	1565	380	15	1 MDP
1	4	510486004	LATERAL ESQUERDA LATERAL IZQUIERDO LEFT SIDE	450	382	15	1 MDP
1	5	510486005	LATERAL DIREITA LADO DERECHO RIGHT SIDE	450	382	15	1 MDP
1	6	510486006	TRAVESSA BASE TABLERO TRAVESAÑO BASE BASE CROSSBOARD	1565	78	15	1 MDP
1	7	510486007	TAMPO TAMPO TOP	1600	384	15	1 MDP
1	8	510486008	MOLDURA TAMPO MARCO SUPERIOR TOP FRAME	1565	40	15	1 MDF
1	9	510486009	DIVISAO SUPERIOR DIVISION SUPERIOR UPPER DIVISION	242	129	12	1 MDP
1	10	510486010	APOIO TRASEIRO BASE BASE DE SOPORTE TRASERO BASE REAR SUPPORT	160	70	15	2 MDP
1	11	510486011	FUNDO INFERIOR (COM FURO) PARTE INFERIOR INFERIOR (CON AGUIERO) LOWER BOTTOM (WITH HOLE)	795	300	2,8	2 MDF
1	12	510486012	FUNDO SUPERIOR (FURO PASSA FIO) PARTE SUPERIOR INFERIOR (ORIFICO PARA PASO DE CABLE) UPPER BOTTOM (WIRE THROUGH HOLE)	1590	147	2,8	1 MDF
1	13	510486013	PE CENTRAL PIE CENTRAL CENTRAL FOOT	120	40	40	1 MDF
1	14	510486014	PORTA BASCULANTE PUERTA SUPERIOR UPLOADING DOOR	778	289	15	2 MDP

TABELA DE ACESSÓRIOS | TABLA DE ACCESORIOS | ACCESSORIES TABLE

	Código Code	Descrição Description	Quantidade Amount
A	160001002	PRENDEDOR DE FUNDOS CLIP DE FONDOS BACKGROUND CLAMP	13
B	160001003	CAVILHAS 8X20MM PASADORES DE 8X20MM PEGES 8X20MM	4
C	160001023	CAVILHA 6X30MM PASADOR 6X30MM PEG 6X30MM	16
D	160001024	PINO GIROFIX PIN FIO PARA NIÑA GIROFIX PIN	20
E	160001025	CASTANHA DO MINI-GIROFIX MINI-GIROFIX CASTAÑO MINI-GIROFIX NUTS	20
F	160001031	FELTRO ADESIVO FIELTRO ADHESIVO ADHESIVE FELT	4
G	160001032	CANTONEIRA PLÁSTICA ESQUINA DE PLÁSTICO PLASTIC CORNER	1
H	160002002	TAMPA ADESIVA CUBIERTA ADHESIVA ADHESIVE COVER	20
I	160002012	GIZ DE CORRECAO TIZA CORRECTORIA CORRECTION CHALK	2
J	160002015	BATENTE SILICONE TAPÓN DE SILICONA SILICONE STOPPER	4
K	160003007	PISTAO A GAS INVERTIDO PISTÓN DE GAS INVERTIDO INVERTED GAS PISTON	2
L	160003012	DOBRODICA CANECA 35MM SUPER CURVA BISAGRA PARA TAZA SUPERCURVA DE 35 MM SUPER CURVED CUP HINGE 35MM	4
M	160005087	PLUXADOR DITO DICHOMANGO DITO HANDLE	2
N	160006008	PARAFUSO 4,5X25 CABECA CHATA TORNILLO DE CABEZA PLANA 4,5X25 FLAT HEAD SCREW 4.5X25	5
O	160006011	PREGO CLAVO NAIL	53
P	160006016	PARAFUSO 3,5X12 CABECA FLANGEADA TORNILLO DE CABEZA CON BRIDA DE 3,5 X 12 FLANGED HEAD SCREW 3.5X12	10
Q	160006020	PINO UNIAO M4 12MM CHATA PASADOR DE UNIÓN M4 PLANO DE 12 MM FLAT M4 UNION PIN 12MM	8
R	160006022	PARAFUSO M4 12MM CHATA TORNILLO PLANO M4 12MM FLAT M4 SCREW 12MM	8
S	160006044	PARAFUSO M4 20MM CABECA CHATA TORNILLO M4 CABEZA PLANA 20MM FLAT HEAD SCREW 20MM	4
T	160006053	PARAFUSO ESTRUTURAL 7X40 CABECA CHATA TORNILLO ESTRUCTURAL CABEZA PLANA 7X40 FLAT HEAD STRUCTURAL SCREW 7X40	5
U	160009049	PE SAPATA NIVELADORA PIE DE ZAPATO NIVELADOR LEVELING SHOE FOOT	1
V	160009067	PE MADEIRA PIE DE MADERA WOODEN FOOT	4
W	160010027	⚠️ KIT FITA LED (OPCIONAL) KIT DE TIRA DE LED (OPCIONAL) LED STRIP KIT (OPTIONAL) ⚠️	1
X	160006034	PARAFUSO 3,5X25 CABECA FLANGEADA TORNILLO DE CABEZA CON BRIDA DE 3,5 X 25 FLANGED HEAD SCREW 3.5X25	9

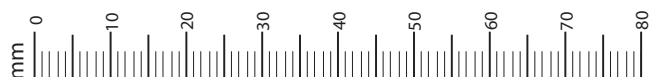

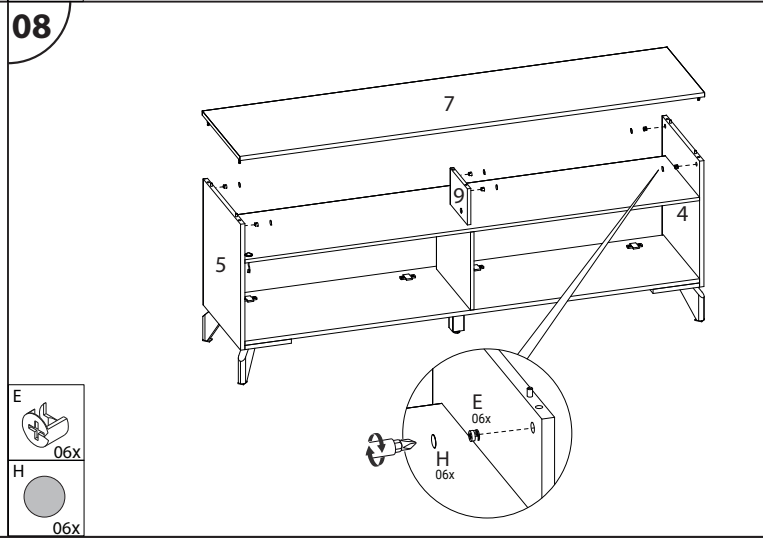
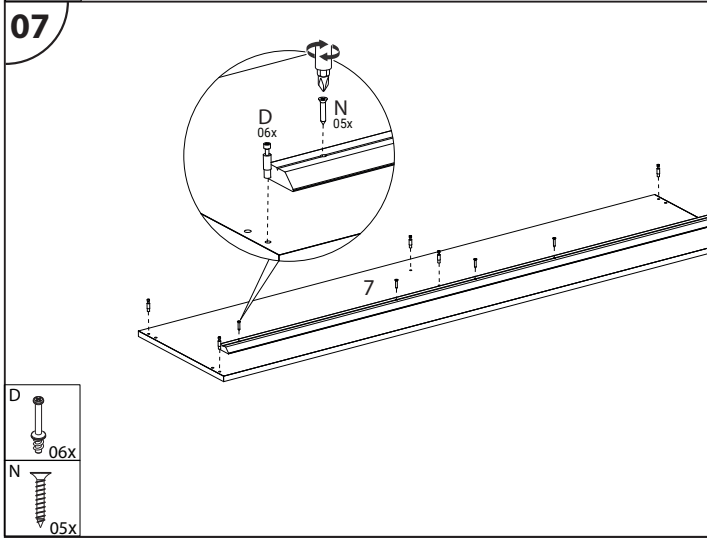
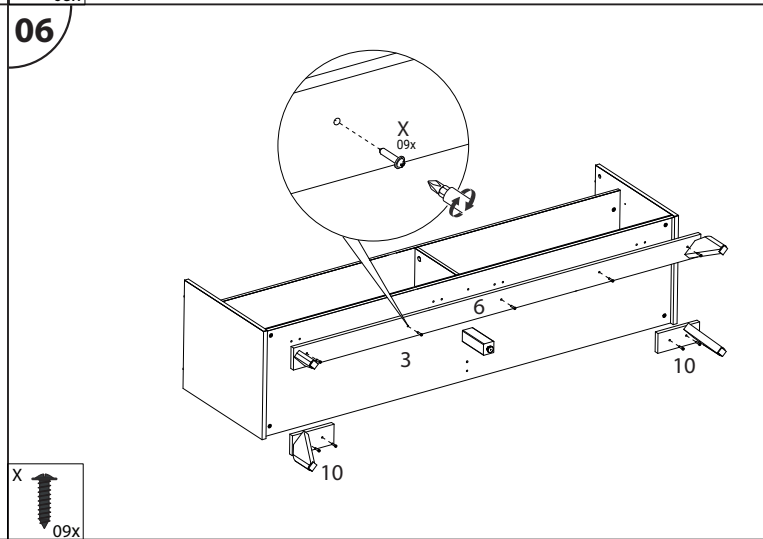
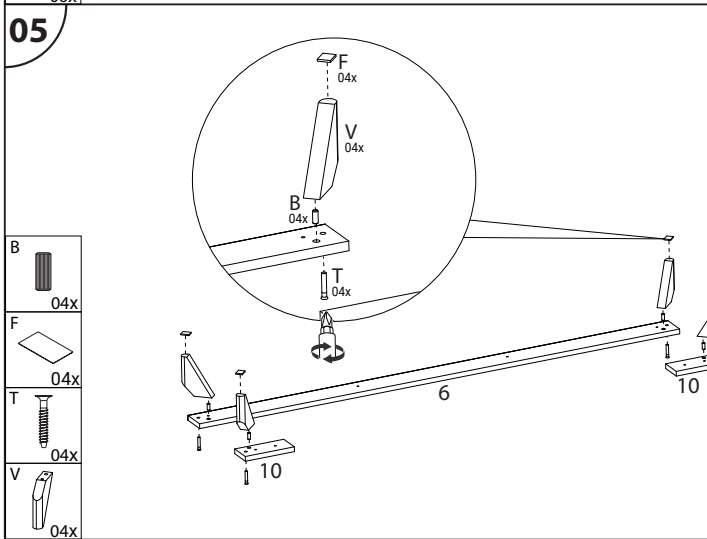
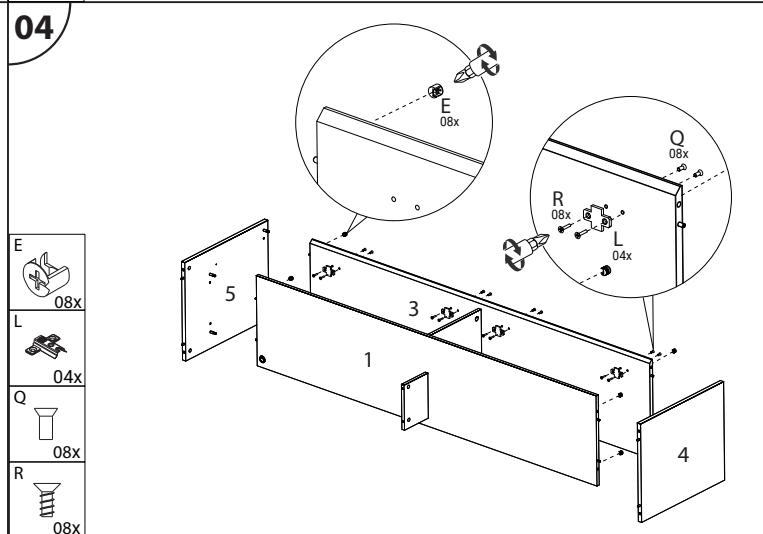
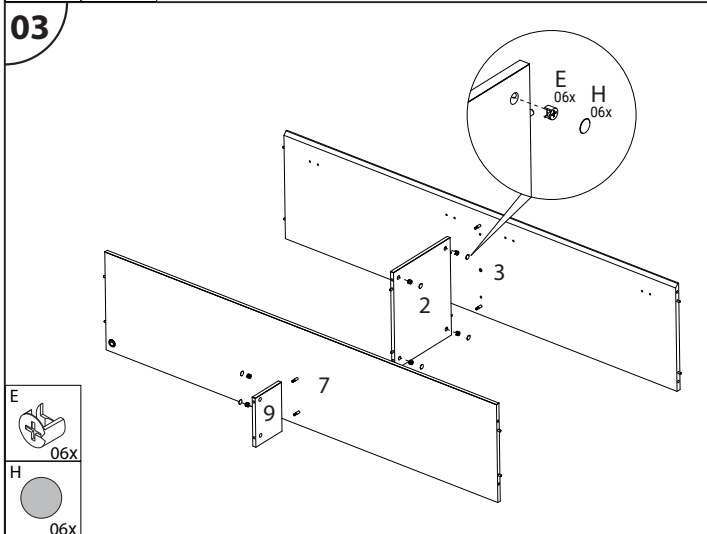
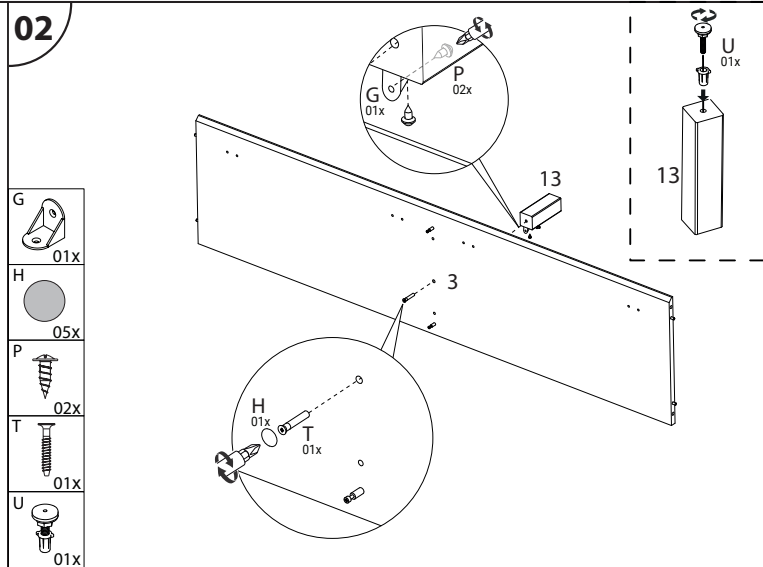
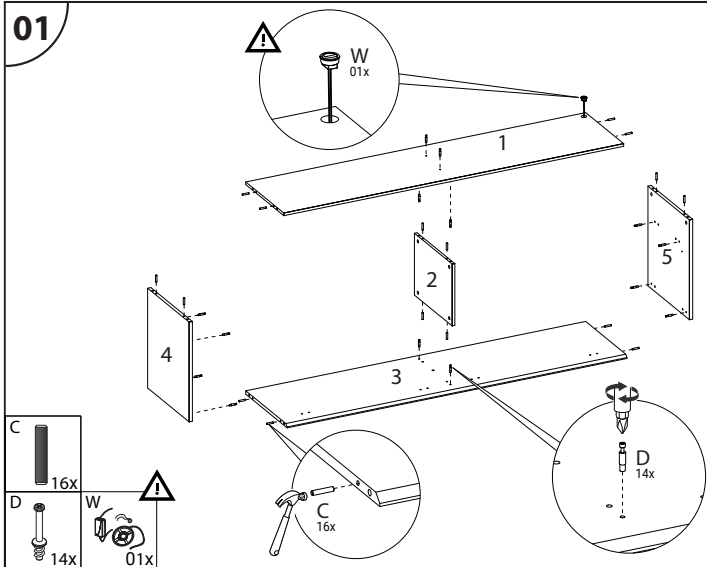

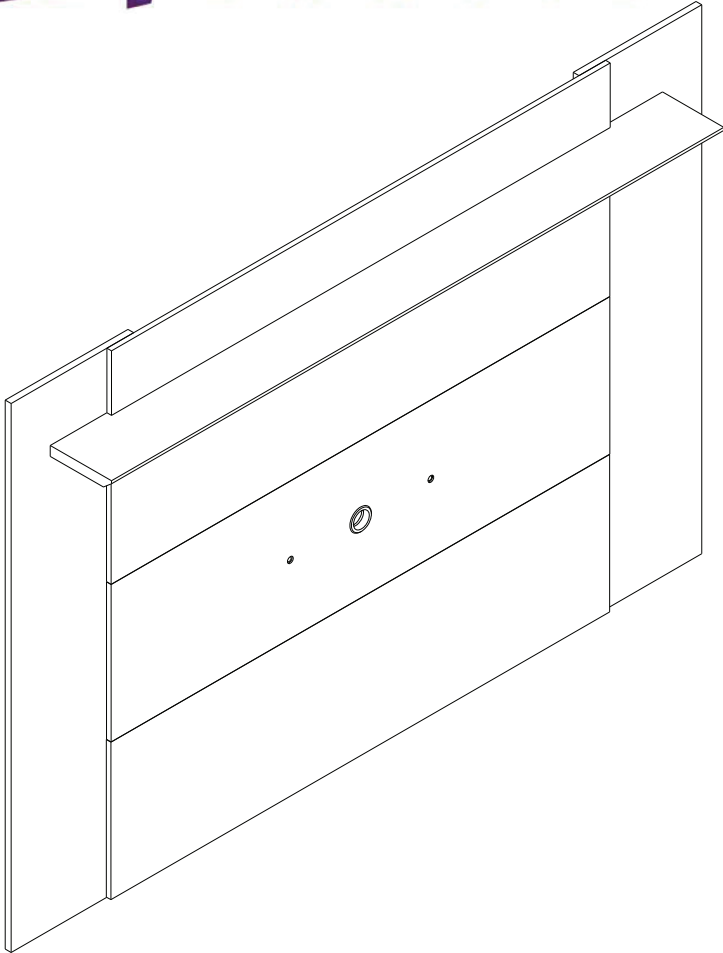

PAINEL TULUM

V-4 08/01/2025

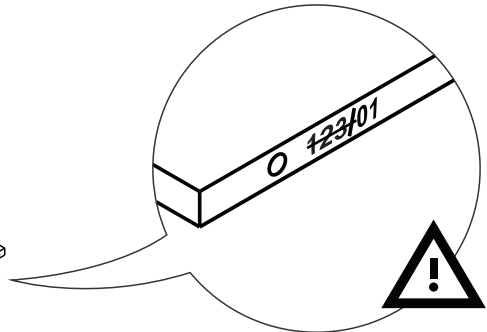
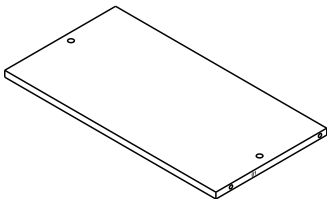
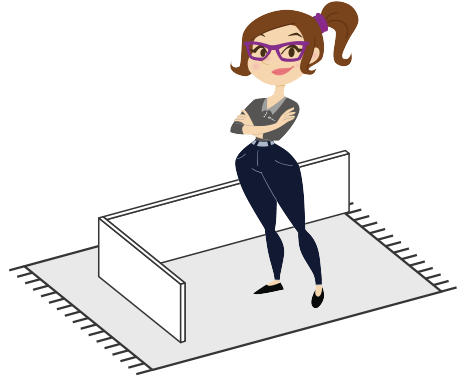
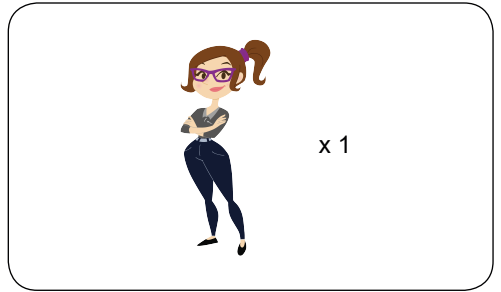
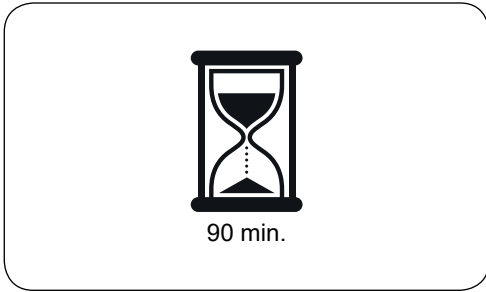
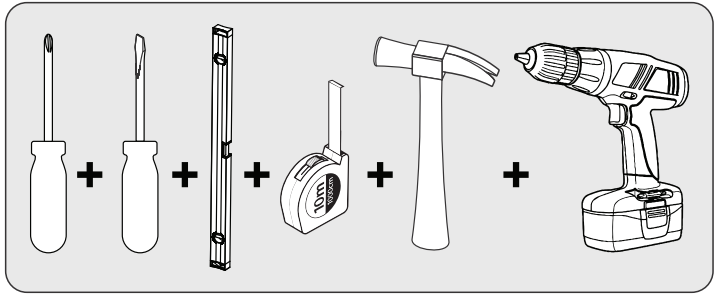
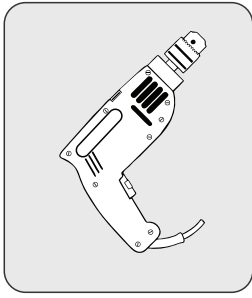

Nossos produtos são garantidos por 90 dias contra defeitos de fabricação. Ao constatar um problema coberto pela garantia, entre em contato com a loja onde o produto foi comprado. Ela estará capacitada para atendê-lo da melhor forma diante de cada caso. Reclamações de garantia somente poderão ser atendidas se o termo de garantia for apresentado no ato de reivindicação, acompanhado de sua nota fiscal de compra.

Nuestros productos están garantidos contra defectos de fabricación por 90 días, a partir de la compra. Ao constatar un problema protegido por la garantía, póngase en contacto con la tienda donde se adquirió el producto. Ella estará capacitada para atenderlo de la mejor manera de acuerdo con cada caso.

Our products are guaranteed against manufacturing defects for 90 days from the date of purchase. When you find a problem covered by the warranty, please contact the store where the product was purchased. The store be able to serve you in the best way in each case.

Exclusões

- Desgaste natural ou danos causados por água, maresia, ferrugem, incêndio, calor, cupins e pragas em geral
- Montagem, manutenção e uso inadequado
- Não cumprimento das recomendações técnicas do esquema
- Montagens e desmontagens após a primeira instalação
- Instalações elétricas e outras afins

Exclusiones

- Desgaste natural o daños causados por agua, maresia, incendios, calor, termitas y plagas en general
- Montaje, mantenimiento y uso inadecuado
- No cumplimiento de las recomendaciones técnicas del esquema
- Montaje y desmontaje después de la primera instalación
- Instalaciones eléctricas y otras afines

Exclusions

- Natural wear or damage caused by water, sea, rust, fire, heat, termites and plagues in general
- Assembly, maintenance and improper use
- Failure to comply with the technical recommendations of the assembly instructions
- Assembly and disassembly after first installation

Importante

A Linha Brasil não autoriza nenhuma pessoa, loja ou entidade assumir em seu nome qualquer outra garantia que não conste no certificado. A fabricante reserva-se no direito de efetuar nos produtos eventuais modificações que considerar necessárias, sem prejudicar as características essenciais. Os produtos terão peças de assistência para reposição no período de 1 ano a contar de sua retirada do mercado, desde que haja matéria-prima equivalente, observando o dispositivo no Art.32 da Lei 8.078/90 (Cód. Defesa do Consumidor). O atendimento para produtos fora de linha é feito por programação especial, através da loja revendedora sob aprovação de consulta prévia ao fabricante.

Importante / Línea Brasil no autoriza a ninguna persona, tienda o entidad a asumir en su nombre cualquier otra garantía que no figure en el certificado. El fabricante se reserva el derecho de efectuar en los productos eventuales modificaciones que considere necesarias, sin perjudicar las características esenciales. Los productos tendrán piezas de asistencia para reposición en el período de 1 año a partir de su retirada del mercado. La atención para productos fuera de línea es hecha por programación especial, a través de la tienda revendedora bajo aprobación de consulta previa al fabricante.

Important / Línea Brasil does not authorize any person, store or entity to assume on its behalf any other warranty that does not appear on the certificate. The manufacturer reserves the right to make in the products any modifications that it considers necessary without prejudice to the essential characteristics. The products will have replacement parts within one year of being withdrawn from the market. The service for off-line products is done by special programming, through the store reseller under prior consultation with the manufacture.

INSTRUÇÕES DE LIMPEZA E CONSERVAÇÃO

CLEAN AND PRESERVATION INSTRUCTURE / INSTRUCCIONES PARA LA LIMPIEZA Y CONSERVACION

Para retirar pó, utilize um pano seco, espanador ou aspirador. Se necessário para uma limpeza mais efetiva, utilize um pano levemente úmido com água. Finalize com uma flanela limpa e seca.

To take dirty, use a dry cloth, duster or vacuum. If necessary to take the dust, use a wet cloth. Finish with a clean and dry flannel.

Para eliminar el polvo, utilice un paño seco, mopa o la aspiradora. Si es necesario para una limpieza más eficaz, con paño ligeramente humedecido con agua. Terminar con un paño limpio y seco.



! IMPORTANTE / IMPORTANT / IMPORTANTE

Não utilize produtos abrasivos como álcool e detergentes, como também esponjas rígidas ou palhas de aço na limpeza dos móveis.

Do not use abrasives such as alcohol and detergent, though soaker also steel wool to clean the furniture.

No use limpiadores abrasivos como alcohol y detergentes, así como esponjas rígidas o lana de acero para limpiar los muebles.



Proteja a superfície do móvel de objetos que transmitam calor ou umidade.

Protect the surface of the furniture against objects that can pass heat and humidity.

Proteja la superficie del mueble de objetos que transmitan calor o humedad.



Evitar o contato de água e produto de limpeza com o rodapé do produto, pois poderá danificá-lo.

Avoid the contact of water and cleaning products with baseboard, cause it should damage your product.

Evitar el contacto con agua y producto de limpieza con el rodapié del producto, pues podrá dañarlo.



Procure sempre utilizar flanela limpa e seca para limpeza.

Try always to use a clean and dry flannel to cleaning.

Busque siempre utilizar franela limpia y seca para la limpieza.



Cuidado com objetos pontiagudos, eles podem arranhar a superfície das portas e tampo.

Take care with sharp objects, they can scratch the door lid surface.

Cuidado con objetos afilados, ellos pueden rayar la superficie de las puertas y la tapa.

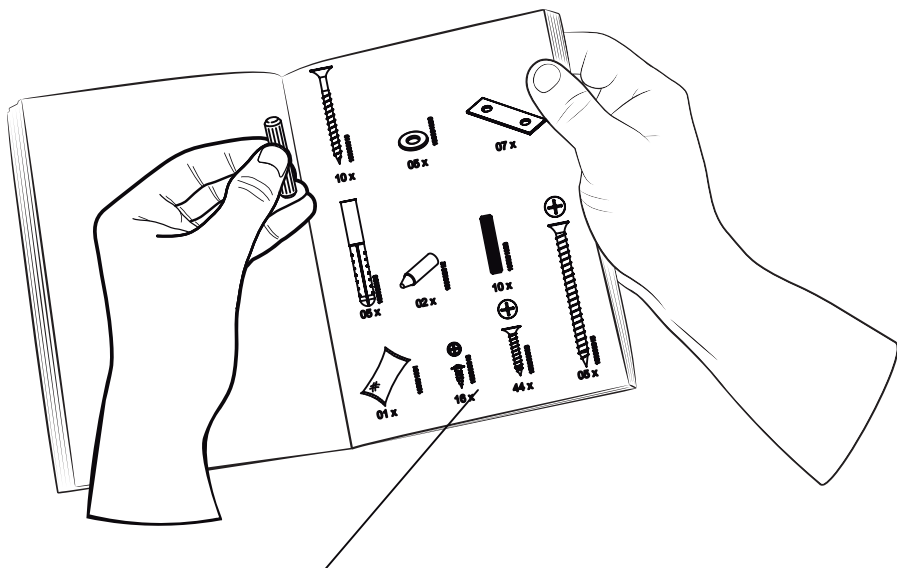

Preste Atenção!
¡Preste atención!
Attention!



As ferragens dos nossos manuais são sempre apresentadas nas mesmas proporções da peça na vida real. Caso apareça alguma dúvida no decorrer do processo de montagem, coloque a ferragem ao lado do desenho e faça a consulta :D

Los accesorios de nuestros manuales siempre se presentan en las mismas proporciones que la pieza en la vida real. Si tiene alguna duda durante el proceso de montaje, coloque los accesorios junto al dibujo y haga una consulta :D

The accessories in our manuals are always presented in the same proportions as the spare part in real life. If you have any questions during the assembly process, place the accessory next to the drawing and make an inquiry :D

Símbolos:
Simbolos:
Symbols:



- + Parafuso Phillips
- Parafuso Fenda
- ⬡ Parafuso Allen
- + Tornillo Phillips
- Tornillo Ranurado
- ⬡ Tornillo Allen
- + Phillipscrew
- Slotted Screw
- ⬡ Allenscrew

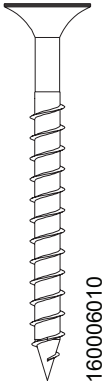

160006010

06 x

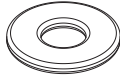

160001009

05 x

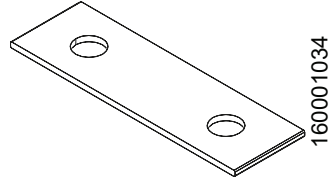

160001034

07 x

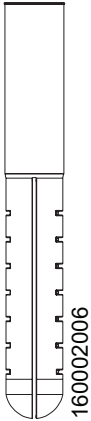

160002006

05 x



160002012

02 x

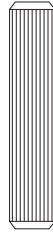

160001023

10 x



160006015

05 x

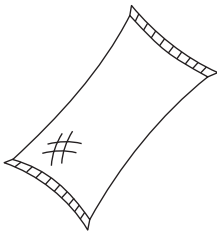

160001001

01 x



160006016

16 x



160006008

44 x

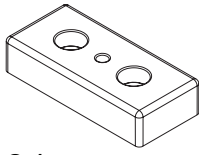

01 x

160002014

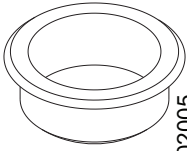

01 x

160002005

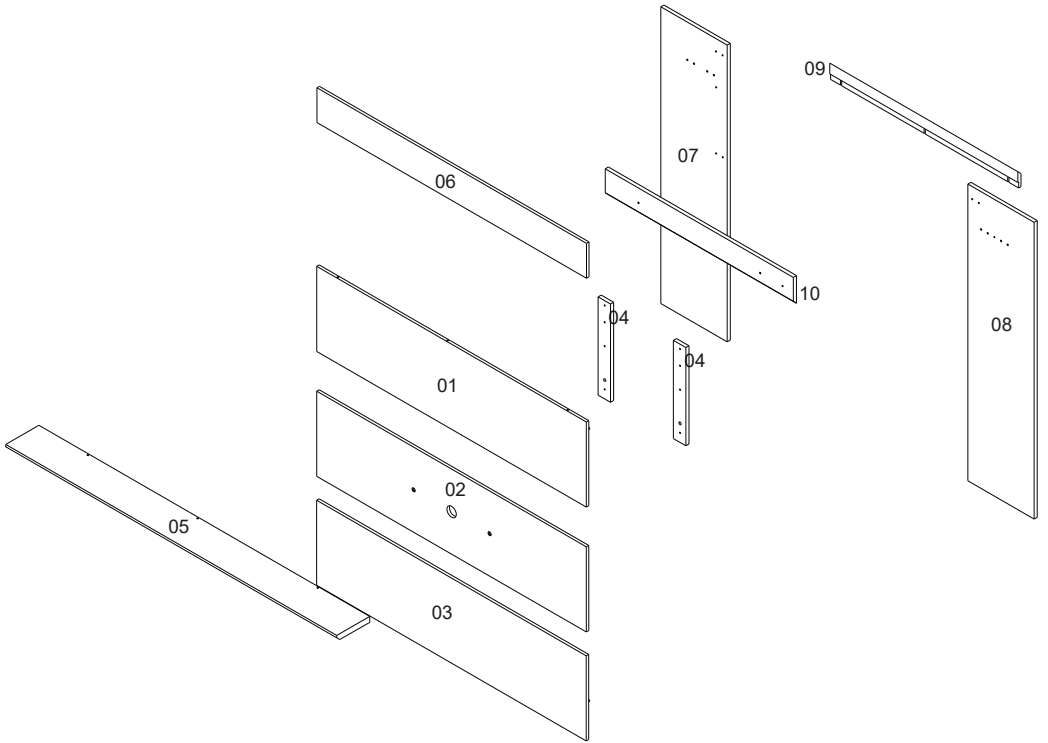

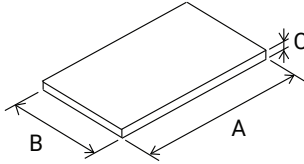

VOLUME Caja Box	ITEM Artículo Item	PEÇA Pieza Part	DESCRIÇÃO Descripción Description	DIMENSÕES (mm) Dimensión/Dimension			QUANTIDADE	MATERIAL
				A	B	C		
1	1	510224001	PAINEL SUPERIOR TV	1300	356	12	1	MDP
1	2	510224002	PAINEL CENTRAL TV	1300	356	12	1	MDP
1	3	510224003	PAINEL INFERIOR TV	1300	356	12	1	MDP
1	4	510224004	TRAVESSA DE FIXAÇÃO	393	60	15	2	MDP
1	5	510224005	PRATELEIRA SUPERIOR	1596	160	25	1	MDP
1	6	510224006	PAINEL SUPERIOR	1300	145	12	1	MDP
1	7	510224007	PAINEL LATERAL ESQUERDO	1239	320	15	1	MDP
1	8	510224008	PAINEL LATERAL DIREITO	1239	320	15	1	MDP
1	9	510224009	TRAVESSA DE PAREDE	906	60	15	1	MDP
1	10	510224010	TRAVESSA PAINEL	906	115	15	1	MDP

ARTÍCULO	DESCRIPCIÓN
1	PANEL SUPERIOR TV
2	PANEL CENTRAL TV
3	PANEL INFERIOR TV
4	DIVISIÓN DE FIJACION
5	ESTANTE SUPERIOR
6	PANEL SUPERIOR
7	PANEL LATERAL IZQUIERDO
8	PANEL LATERAL DERECHO
9	DIVISIÓN DE PARED
10	DIVISIÓN DE PANEL

ITEM	DESCRIPTION
1	UPPER TV PANEL
2	CENTRAL TV PANEL
3	LOWER TV PANEL
4	FIXING DIVISION
5	UPPER SHELF
6	UPPER PANEL
7	LEFT SIDE PANEL
8	RIGHT SIDE PANEL
9	WALL DIVISION
10	PANEL DIVISION

CÓDIGO Codigo Code	DESCRIÇÃO Descripción Description	QUANTIDADE La Cantidad The Amount
510228011	KIT ACESSORIO PAINEL EXTENSIVEL TULUM KIT ACCESORIO PAINEL EXTENSIBLE TULUM TULUM EXTENDABLE PANEL ACCESSORY KIT	1
160001001	COLA PARA MONTAGEM PEGAMENTO GLUE	1
160001023	CAVILHA 6X30MM TARUGO 6x30 MM DOWEL 6x30 MM	10
160001034	CHAPA DE JUNÇÃO PLACA DE JINCIÓN CONNECTOR PLATE	7
160002005	GUIA CABO PASSA FIO TAPA PASACABLES CABLE HIDDEN COVER	2
160001024	PINO GIROFIX PERNO MINIFIX CAM SCREW	12
160002006	BUCHA 8MM TACOS 8 MM ANCHOR 8 MM	5
160002012	GIZ DE CORRECAO TIZA DE CORRECCION CRAYON REPAIR	2
160002014	DISTANCIADOR DE PAINEL DISTANCIADOR DE PANEL PANEL SPACER	1
160006008	PARAFUSO 4,5X25 CABECA CHATA TORNILLO CABEZA PLANA 4,5x25 FLAT HEAD SCREW 4,5x25	44
160006010	PARAFUSO 4,5X50 CABECA CHATA TORNILLO CABEZA PLANA 4,5x50 FLAT HEAD SCREW 4,5x50	6
160006015	PARAFUSO 6,0X75 CABECA CHATA TORNILLO CABEZA PLANA 6,0x75 FLAT HEAD SCREW 6,0x75	5
160006016	PARAFUSO 3,5X12 CABECA FLANGEADA TORNILLO CABEZA BRIDA 3,5x12 FLANGE HEAD SCREW 3,5x12	16
160001009	ARRUELA 3/16 15MM ARANDELA 3/16 15 MM WASHER 3/16 15 MM	5

1

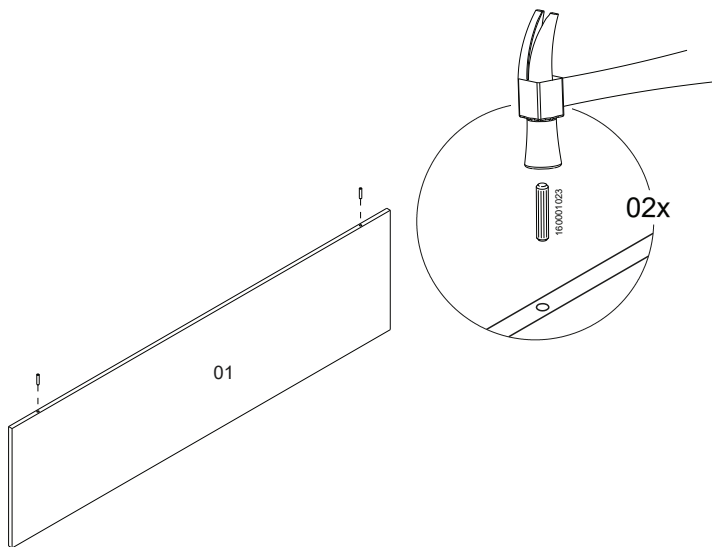
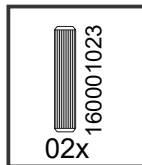

2

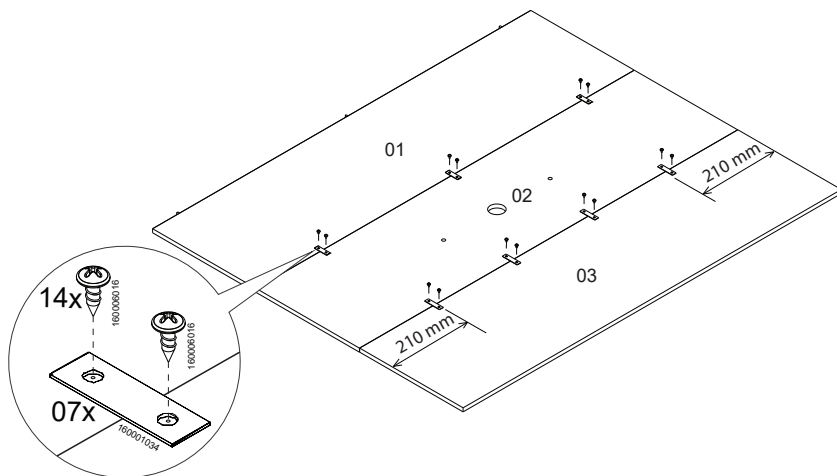
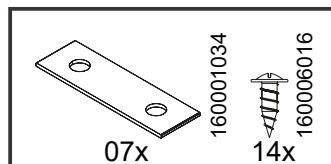

03

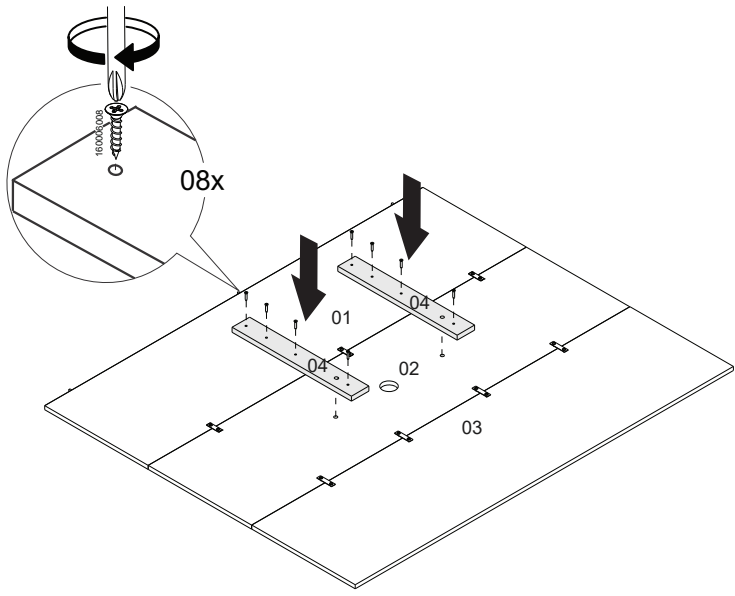
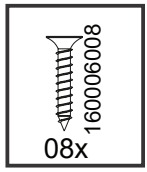

04

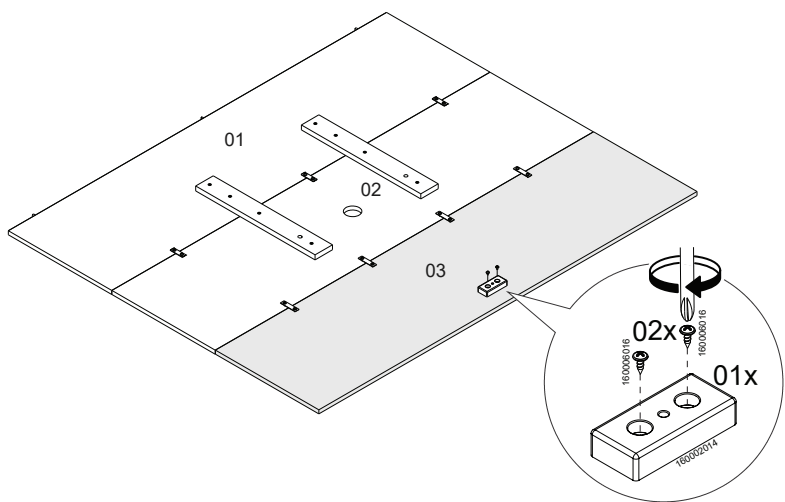
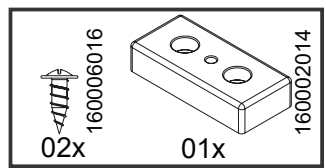

05

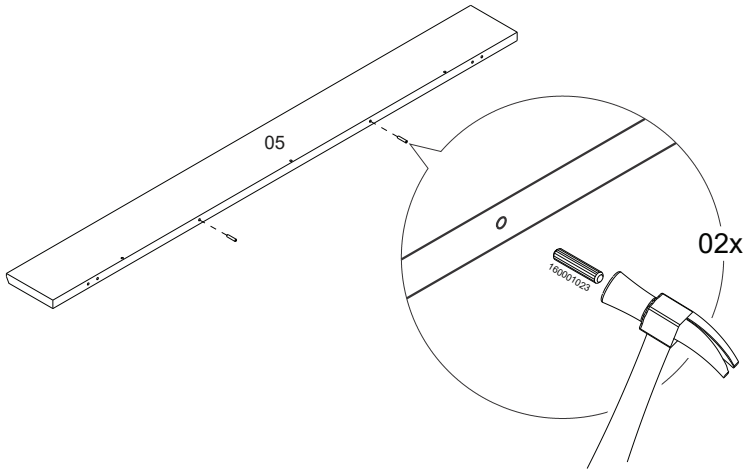
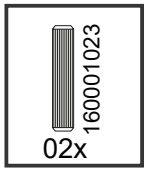

06

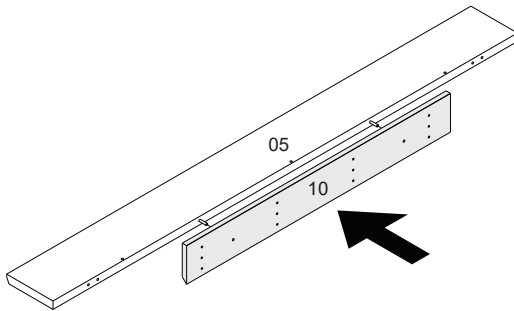

07

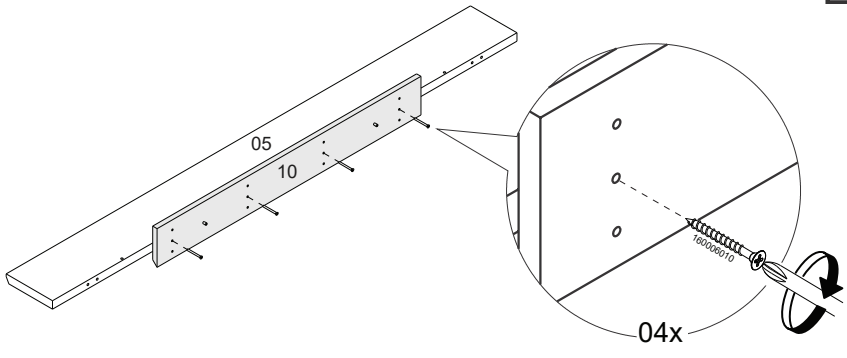
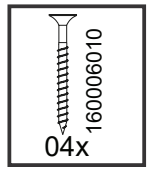

08

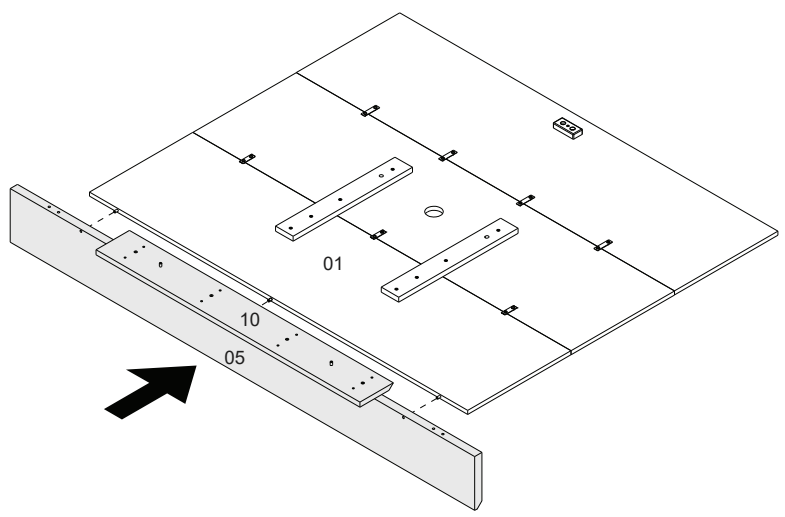

09

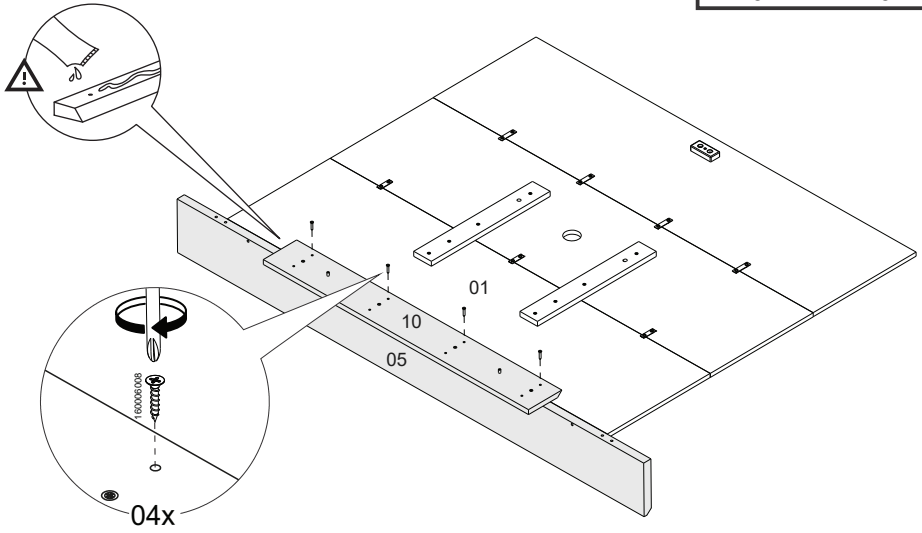
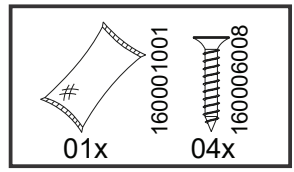

10

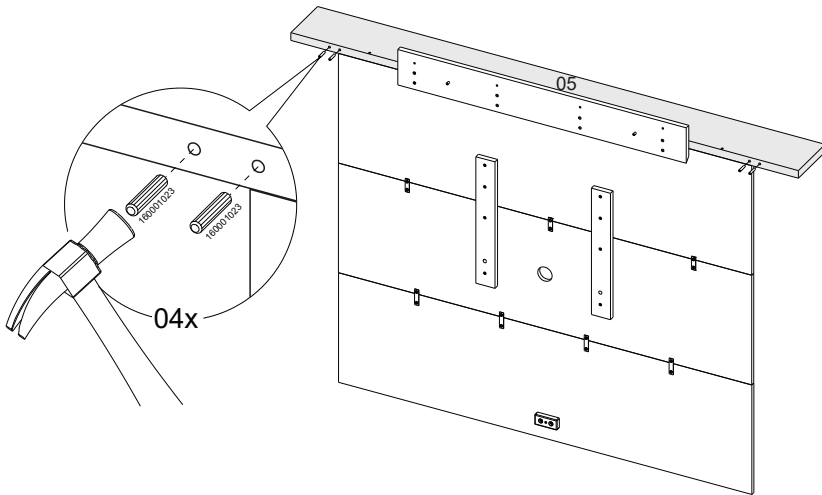
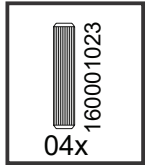



Preste Atenção!
¡Preste atención!
Attention!

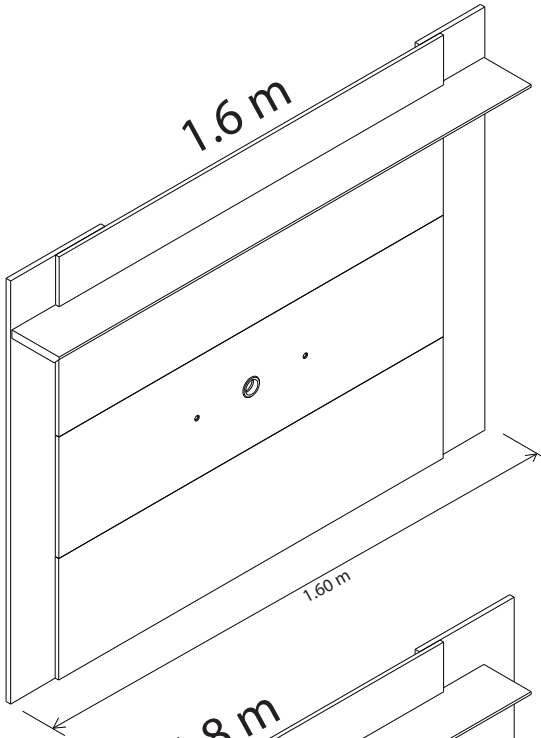

11

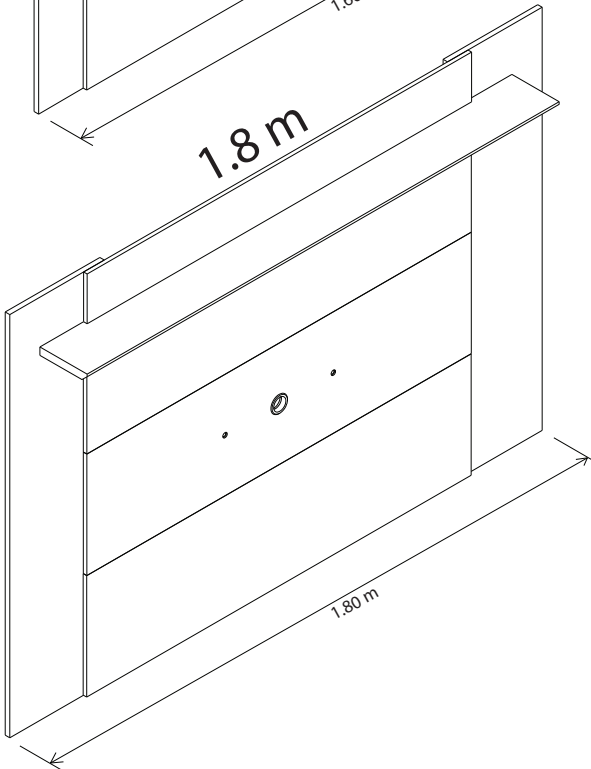

12

11

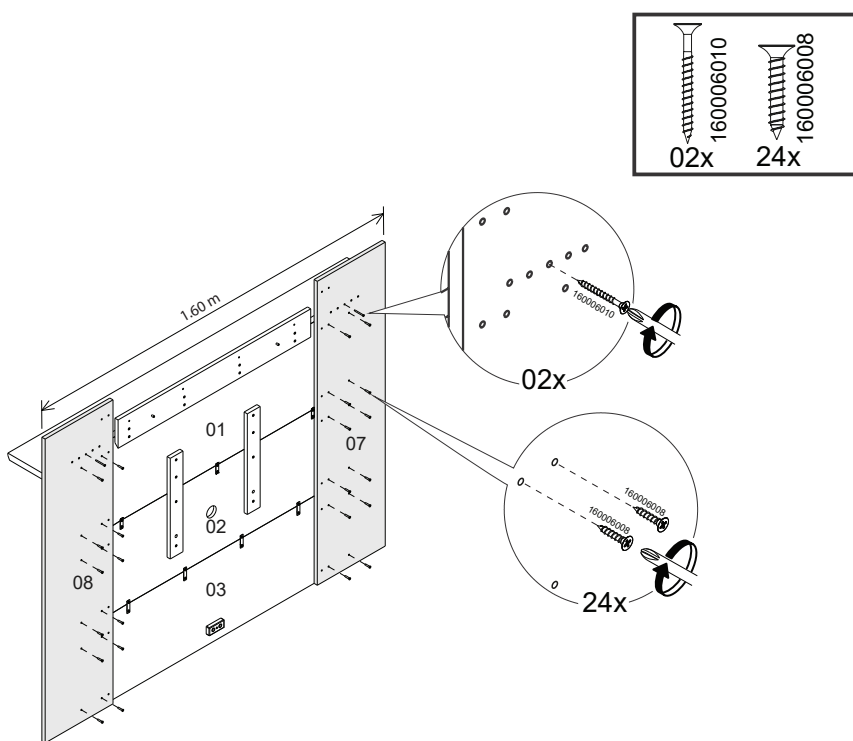

12

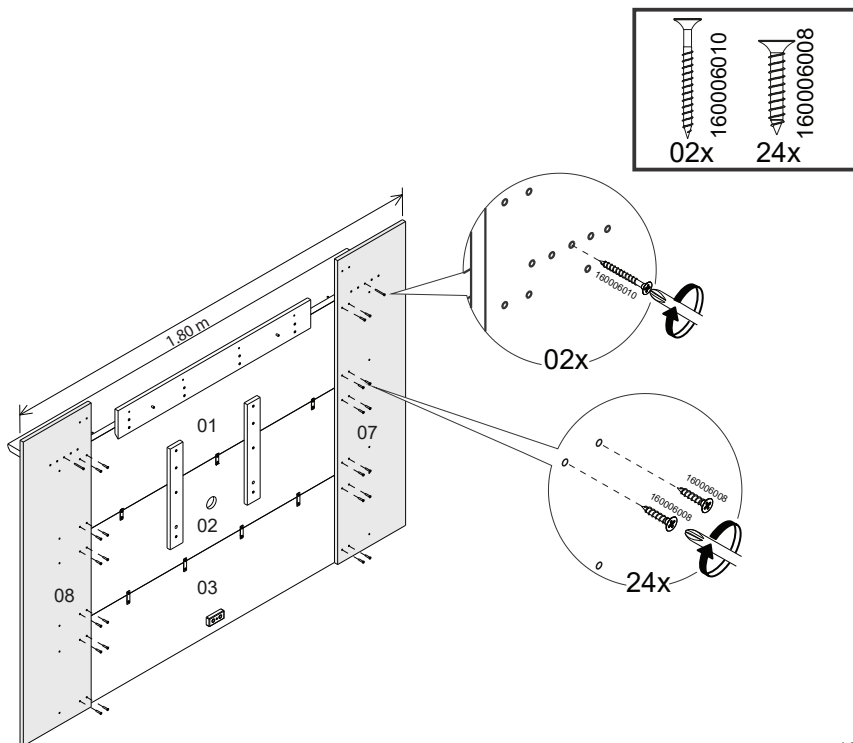

13

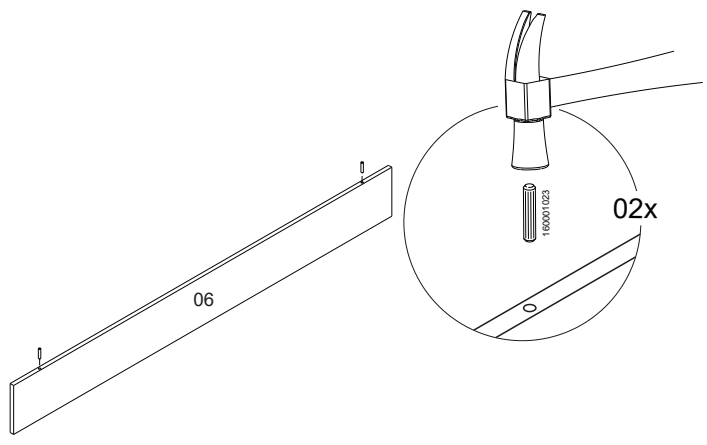
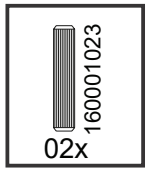

14

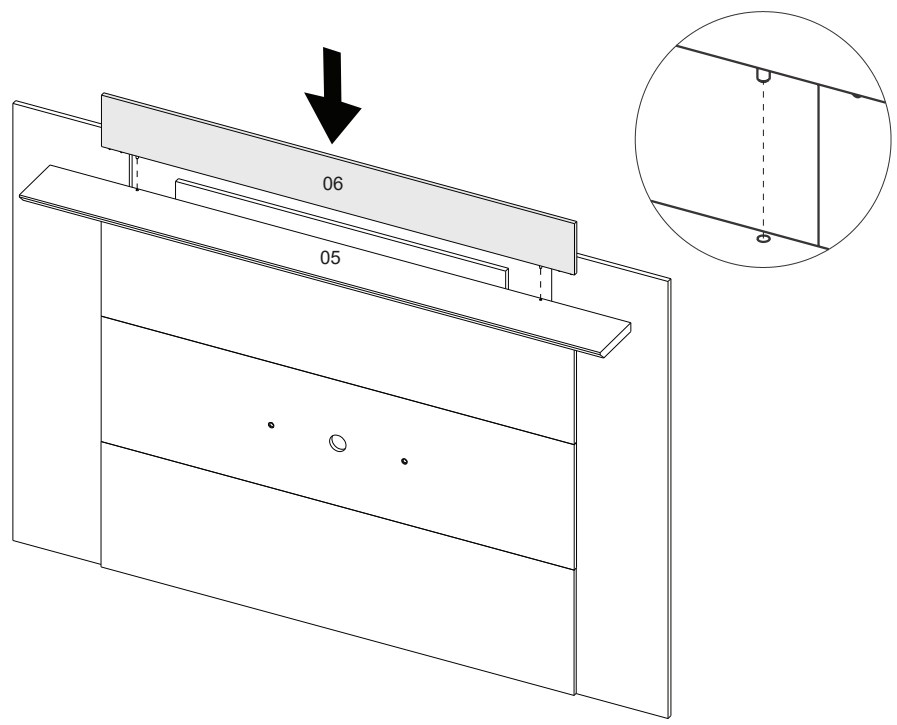

15

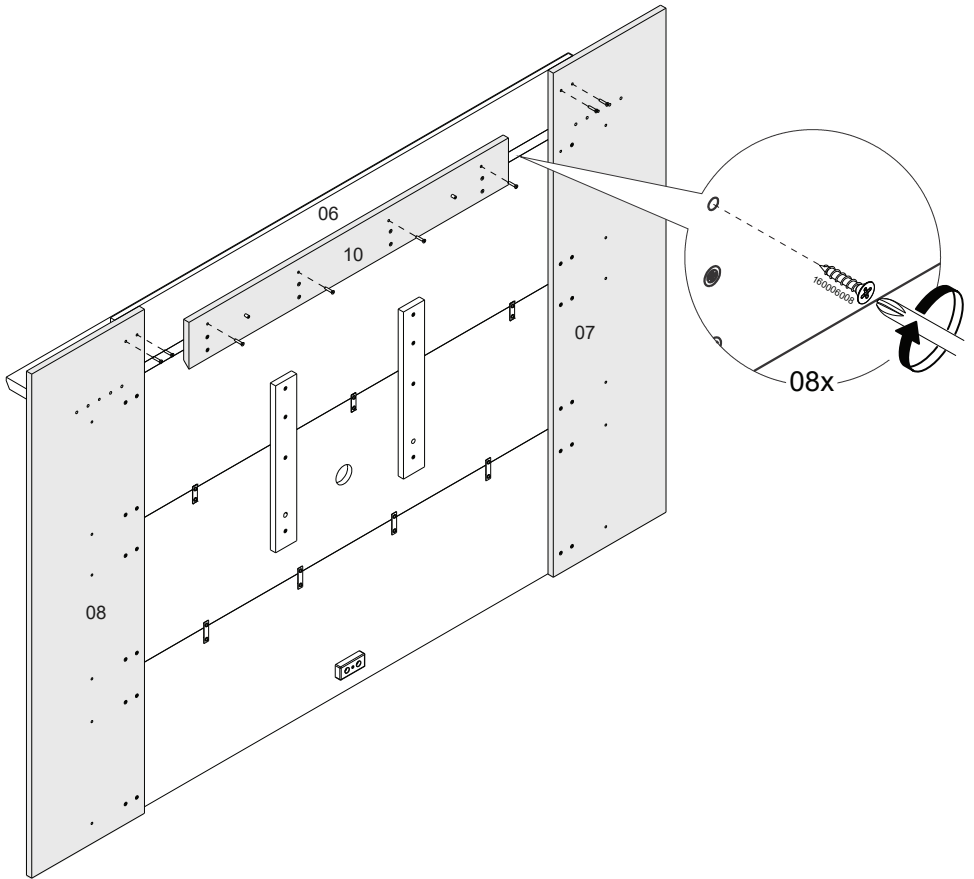
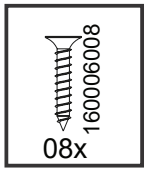

16

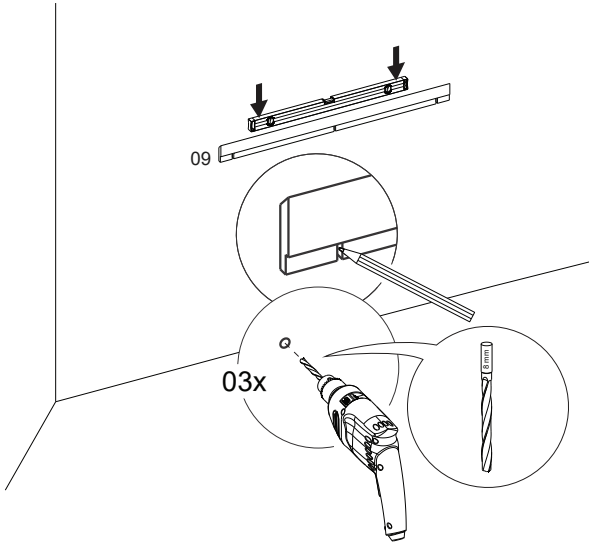

17

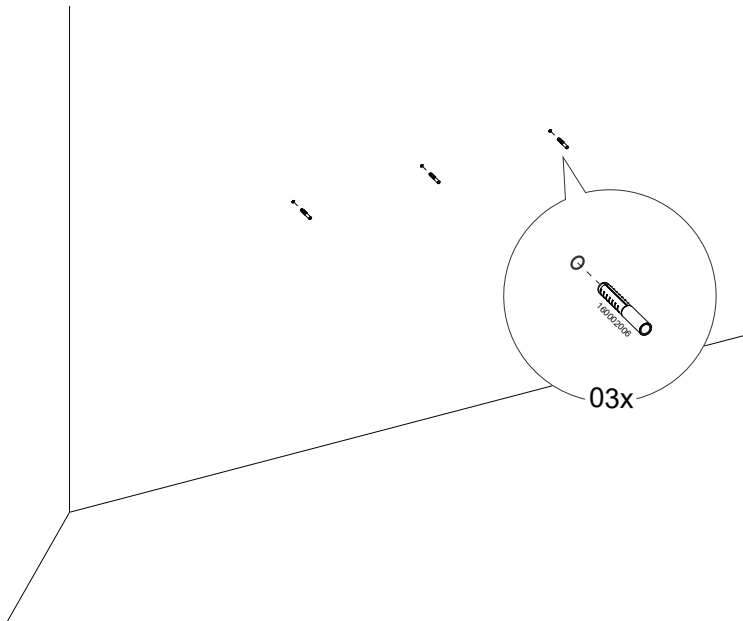
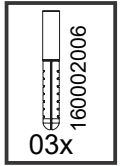

18

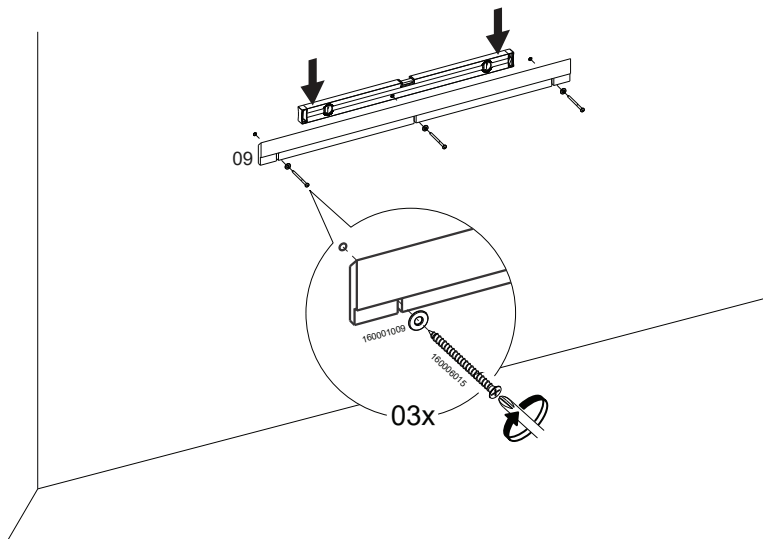
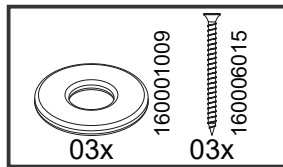

19

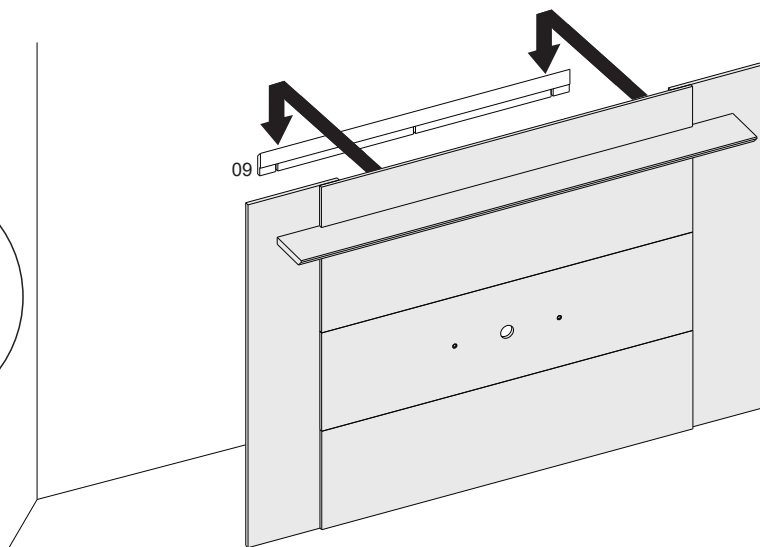
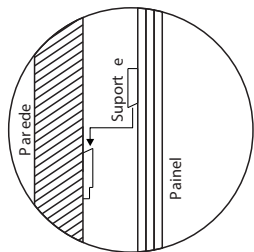

20

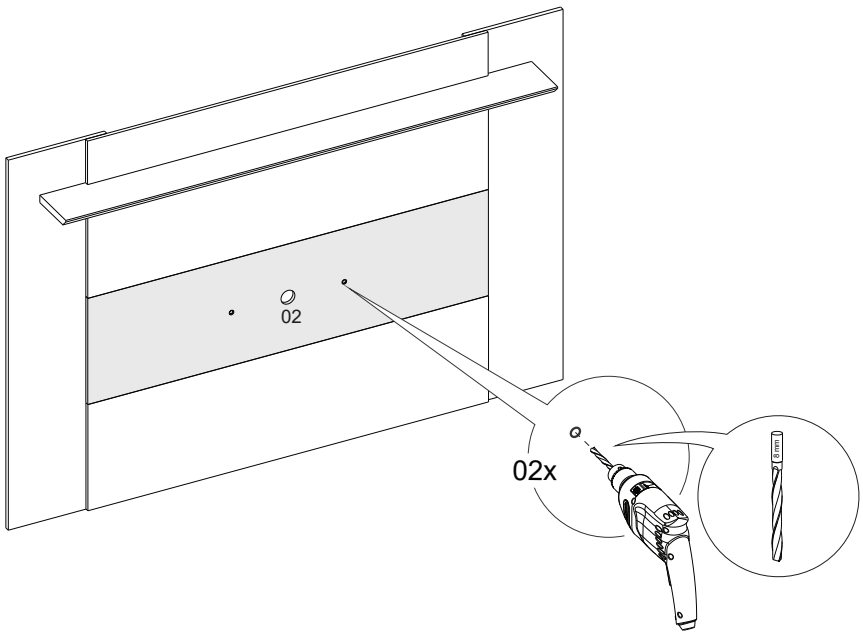

21

