

07 Fixação do Tampo e da Moldura Superior e Lateral

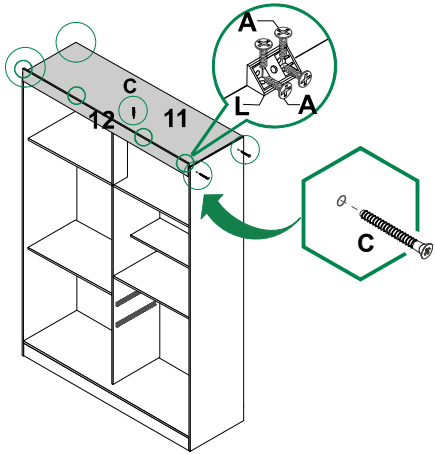

Sr. Montador
Favor fixar o conector de montagem
a 5mm da Borda fileada da Moldura Superior

08 Fixação das Costas

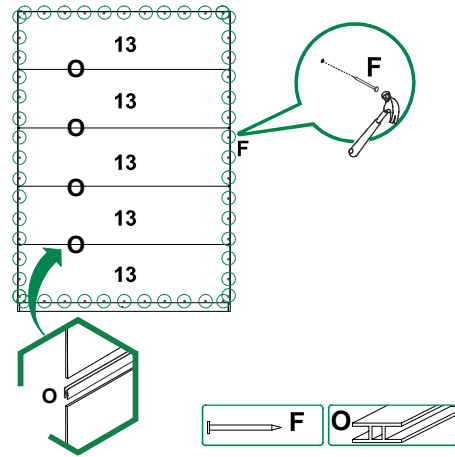

09 Montagem das Gavetas

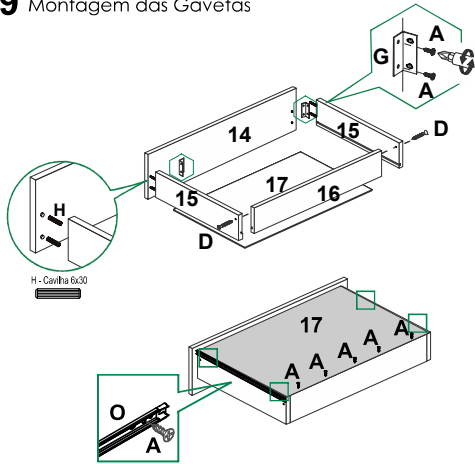

10 Montagem das Portas

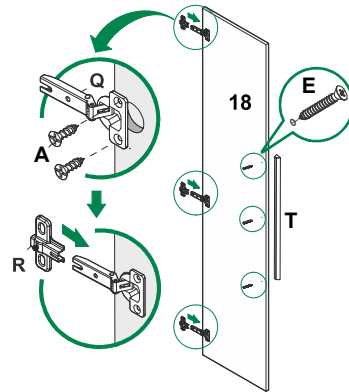

11 Fixação do Suporte Cabideiro

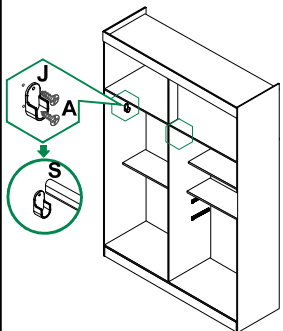

12 Colocação das Gavetas

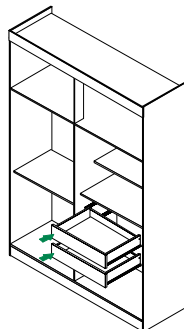

13 Fixação das portas

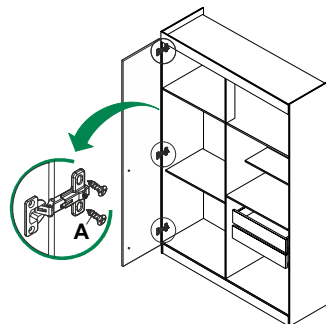

Sallêto



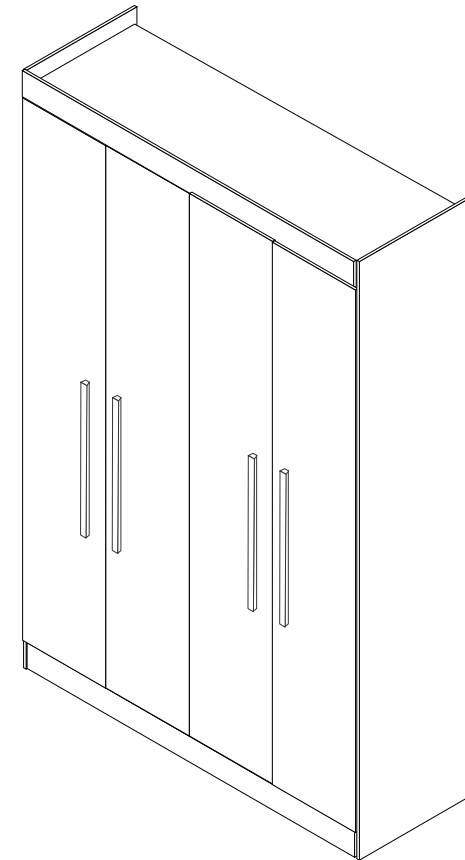
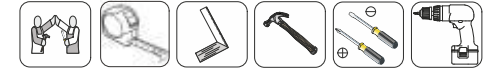











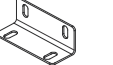

ROUPEIRO
FRANÇA
4 PORTAS

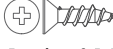

LISTA DE PEÇAS

CÓD.	Nº.	DESCRIÇÃO	COMP.	LARG.	ESP.	QT
15316	01	Rodapé Frontal Pintado	1188	100	12	1
15315	02	Rodapé Traseiro Cru	1188	100	12	1
15317	03	Travessa Rodapé Cru	405	100	12	1
15311	04	Lateral Esquerda	2000	450	12	1
15312	05	Lateral Direita	2000	450	12	1
15313	06	Base Inferior	1188	450	12	1
15314	07	Divisão Interna	1348	450	12	1
15318	08	Prateleira Menor	588	330	12	3
15313	09	Prateleira do Maleiro	1188	450	12	1
15324	10	Batente da Porta	450	110	12	1
15313	11	Tampo Superior	1188	450	12	1
15323	12	Moldura Superior	1210	70	15	1
15325	13	Costa do Roupeiro	1207	363	3	5
15319	14	Frente da Gaveta	534	165	12	2
15320	15	Lateral da Gaveta	300	110	15	4
15321	16	Traseiro da Gaveta	484	70	12	2
15326	17	Fundo da Gaveta	499	307	3	2
15322	18	Portas	1830	297	12	4

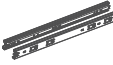
LISTA DE FERRAGENS

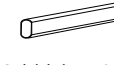
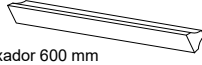
A		X116	B		X06	C		X30
	Parafuso 3,5x12		Pés (Opcionais)				Parafuso 5x40 (montagem da estrutura)	
D		X12	E		X12	F		X80
	Parafuso 3,5x35		Parafuso 3,5x25 (Puxador Porta)				Prego 8x8	
G		X04	H		X11	I		X04
	Cantoneira 4 furos para gaveta		Cavilha 6x30				Cavilha 6x50	
J		X02	L		X03	M		X08
	Suporte Cabide		Conector				Calço Corrediça	
K		X06	N		X16	O		X04
	Sapata		Parafuso 3,5x16				Perfil H 1205mm	
P		X02	Q		X12	R		X12
	Corrediça Telescopica 300 mm		Dobradiça				Calço Dobradiça	
S		X01	T		X04			
	Cabideiro 580mm		Puxador 600 mm					

Ao solicitar assistência, informe o número da peça e a letra do acessório

01 Início da Montagem

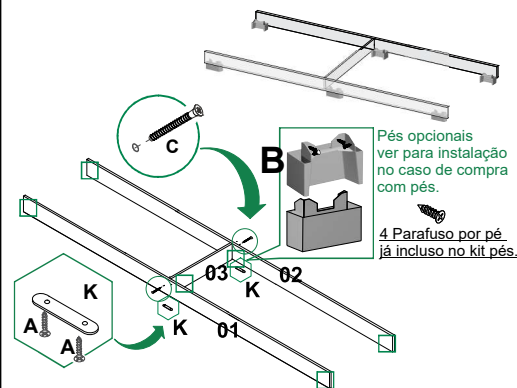

02 Montagem das Laterais

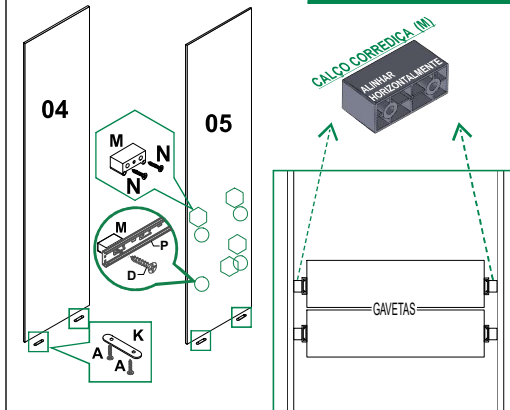

03 Montagem da Lateral Direita e Esquerda

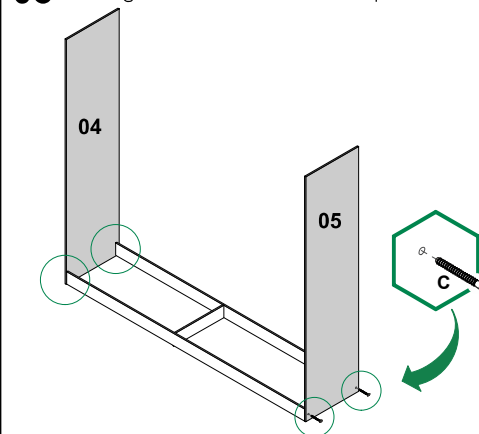

04 Fixação das Divisões

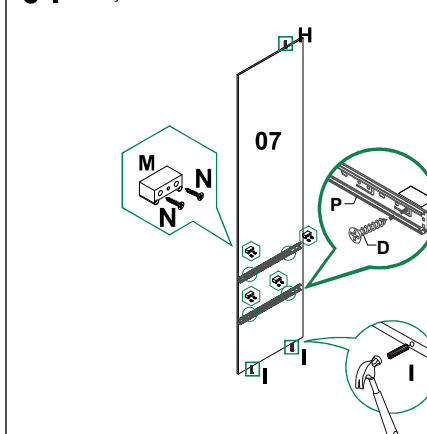

05 Montagem das Divisões na Base

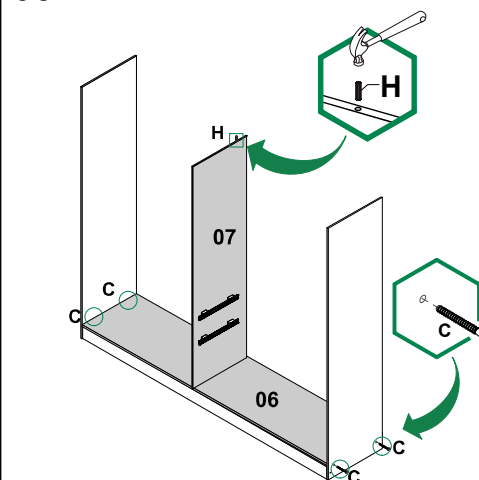

06 Montagem das Prateleiras e do Tampo Superior

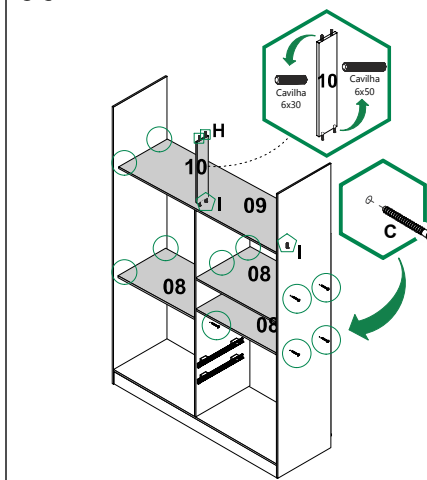

ATENÇÃO: O MÓVEL PODE SER MONTADO TANTO PARA DIREITA QUANTO PRA ESQUERDA!

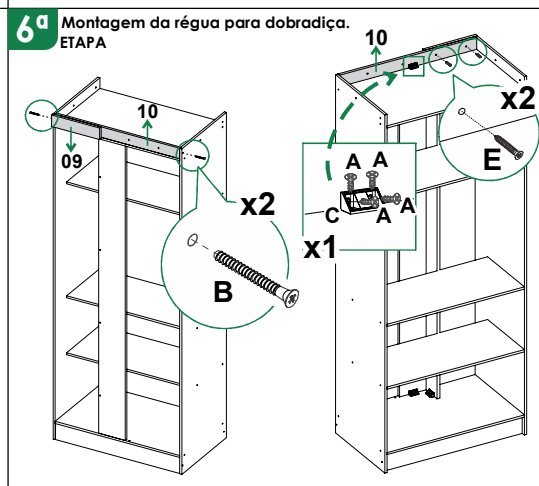
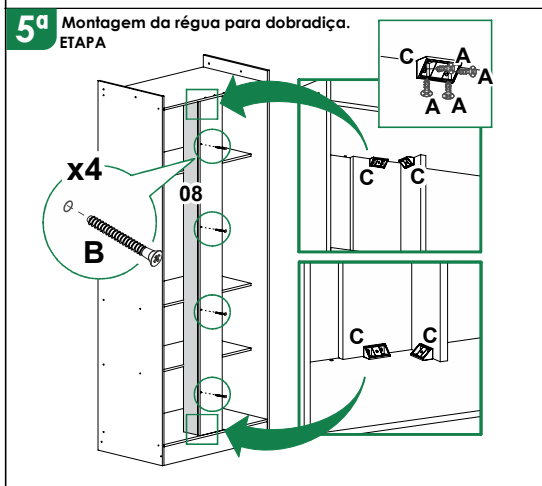
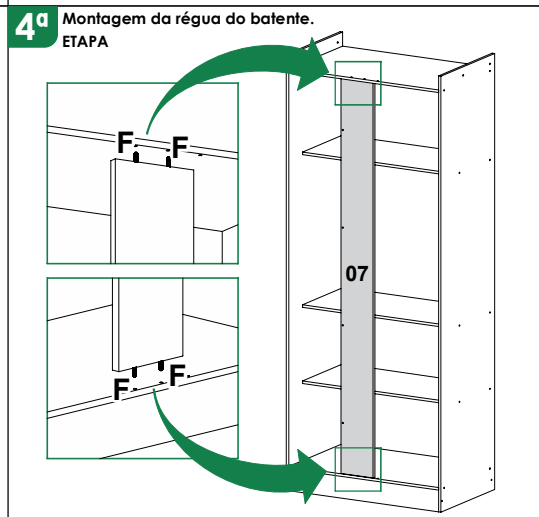
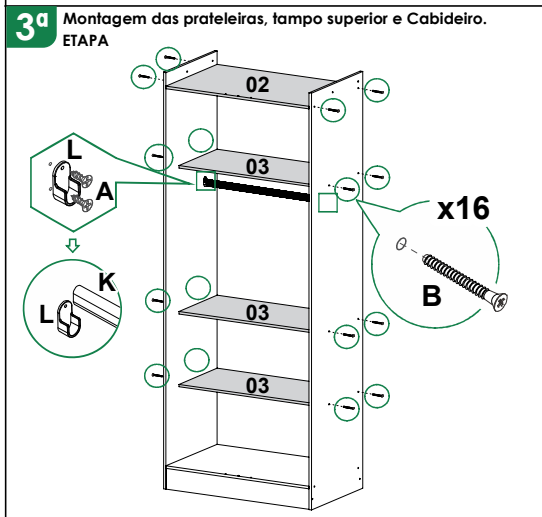
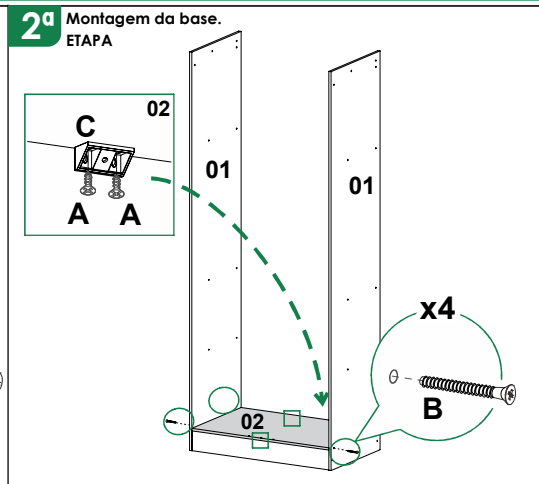
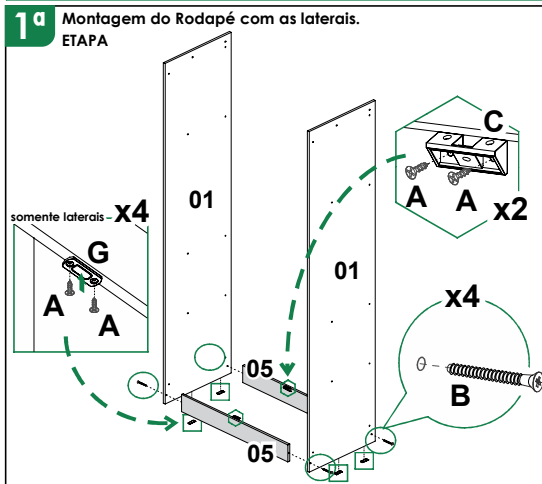

Sallêto

MODULADO CANTO FORTALEZA

01 PORTA



Encontre um montador
mais próximo de você:



Atualizado em:
06/01/26







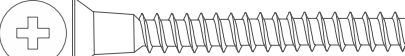
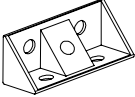

Av. Jesus Candian, 800-Caixa Postal 116
CEP36503-258-Mangueira Rural-Ubá / MG
www.salletomoveis.com.br

(32) 3541-6777

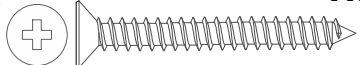
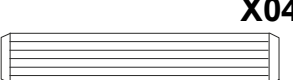
LISTA DE PEÇAS

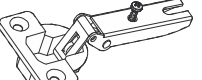
CÓD.	ITEM	DESCRIÇÃO	Comp.	Larg.	Esp.	Qt.
18019	01	Lateral Esquerda / Direita Canto Fortaleza	2000	450	12	2
18029	02	Tampo e Base Canto Fortaleza	725	450	12	2
18022	03	Prateleira Interna Canto Fortaleza	725	335	12	3
18020	04	Porta Canto Fortaleza	1830	268	12	1
18027	05	Rodapé Traseiro Cru Canto Fortaleza	725	100	12	1
18026	06	Rodapé Frontal Pintado Canto Fortaleza	725	100	12	1
18021	07	Régua Batente Canto Fortaleza	1810	155	15	1
18023	08	Régua Dobradiça Canto Fortaleza	1810	100	15	1
18025	09	Moldura Superior Frontal Menor Canto Fortaleza	280	70	15	1
18028	10	Moldura Interna Superior Canto Fortaleza	725	65	15	1
18030	11	Costas Canto Fortaleza	1835	370	3	2
18024	12	Moldura Superior Frontal Maior Canto Fortaleza	410	70	15	1

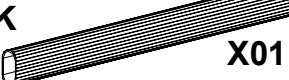
LISTA DE FERRAGENS

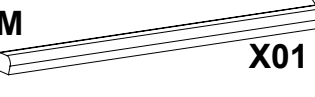
A		X52	B		X30
Parafuso 3,5x12			Parafuso 5,0x40		
C		X07	D		X60
Cantoneira 4 Furos			Prego 8x8		
E		X05	F		X04
Parafuso 3,5x25			Cavilha 6x30		
G		X04	H		X01
Sapatas Deslizantes			Perfil H 1830mm		
I		X03	J		X03
Dobradiça 26mm Curva			Calço dobradiça 7mm		
K		X01	L		X02
Cabideiro 718mm			Suporte de Cabideiro		
M		X01			
Puxador 600x20x15mm					

Ao solicitar assistência, informe o número das peças e dos acessórios

7ª Montagem das Portas. ETAPA

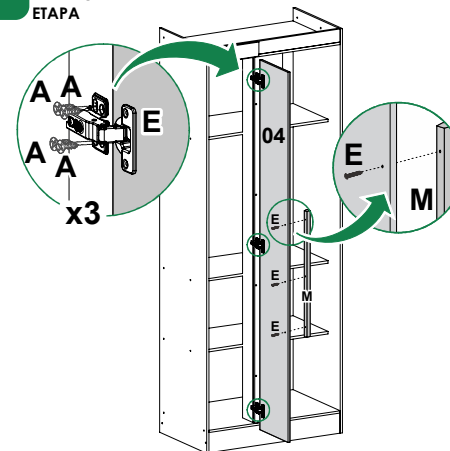

8ª Fixação das Costas. ETAPA

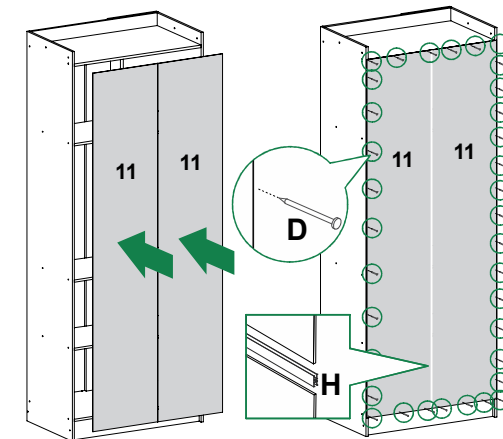

9ª Fim da Montagem. ETAPA

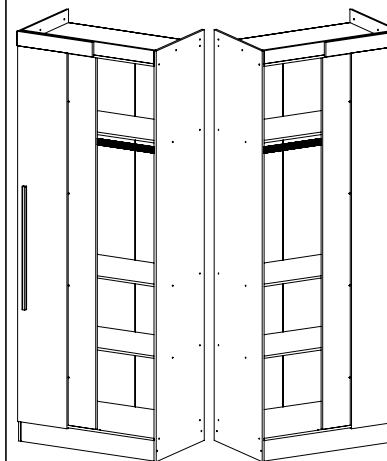

Possíveis Modulações.

Roupeiros
Recife 4, 6 e 8
Portas

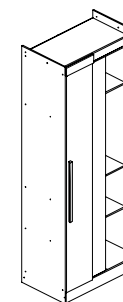

Modulado Apollo

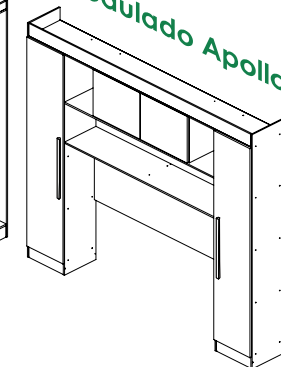

MODULADO APOLLO DEVE SEMPRE SER ENCAIXADO NA PARTE FRONTAL DO CANTO!!

FIXAÇÃO DOS MÓDULOS A CRITÉRIO DO MONTADOR!

Roupeiros
Recife 4, 6 e 8
Portas

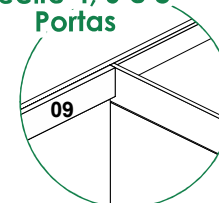

Modulado Apollo

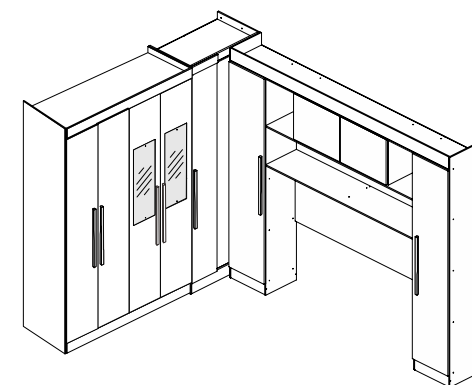
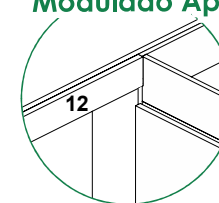

ATENÇÃO: UTILIZAR MOLDURA SUPERIOR MAIOR PARA ROUPEIROS E MOLDURA SUPERIOR MENOR PARA O MOD. APOLLO!

Aproveite seus móveis!

06 Montagem do Maleiro

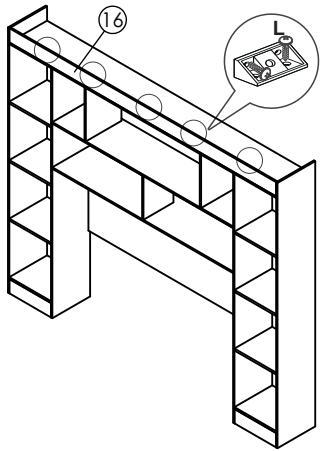

07 Fixação da Moldura Superior e Lateral

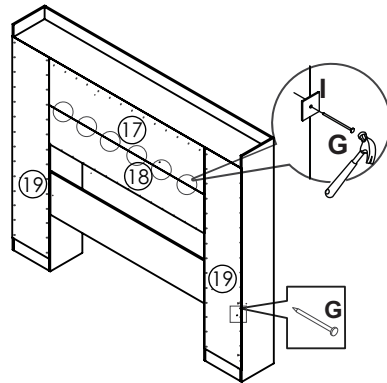

10 Montagem das Portas Superiores

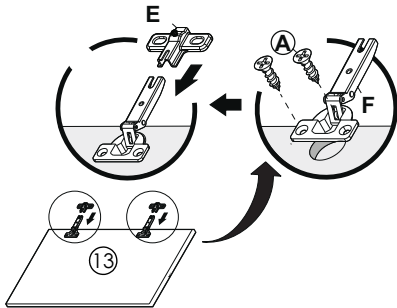

09 Montagem das Gavetas

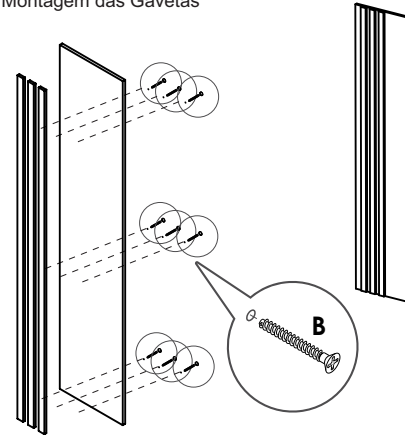

10 Montagem das Portas

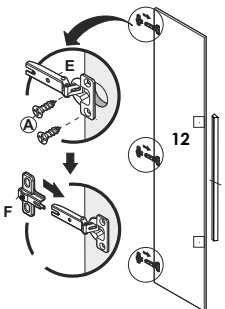

11 Fixação dos cabideiros

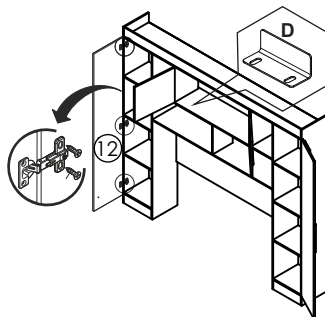

12 Fixação das portas

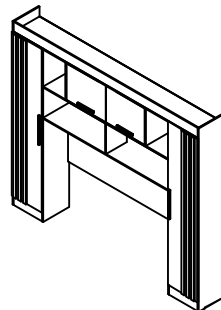

Sallêto

MÓDULO APOLO

04 PORTAS

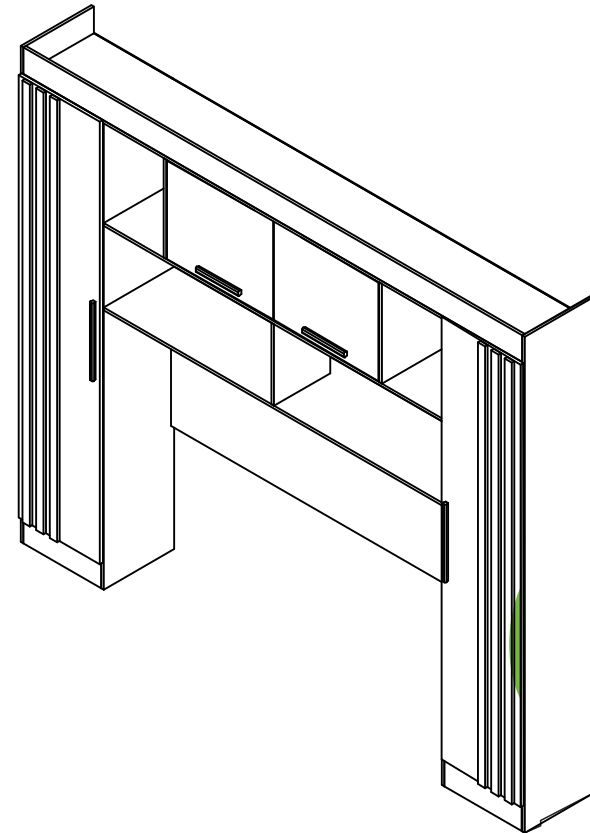

Atualizado em:
24/11/2023

Av. Jesus Candian, 800-Caixa Postal 116
CEP36503-258-Mangueira Rural-Ubá / MG
www.salletomoveis.com.br











(32) 3541-6777

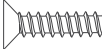

LISTA DE PEÇAS

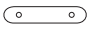
CÓD.	Item	Descrição	Mat.	Comp.	Larg.	Esp.	Qt.	VOL.
15438	19	Costa vertical_Modulado	MDF	385	1820	3	2	1/2
15439	18	Costa Horizontal_Modulado	MDF	1618	353	3	1	1/2
15440	17	Costa Horizontal superior_Modulado	MDF	1618	430	3	1	1/2
15441	16	Moldura superior_Modulado	MDP	2370	110	12	1	1/2
15442	15	Rodapé traseiro_modulado	MDP	370	110	15	2	1/2
15443	14	Rodapé frontal_Modulado	MDP	370	110	12	2	1/2
15444	13	Porta menor_Modulado	MDP	500	405	15	2	1/2
15445	12	Porta_Moldurado	MDP	1820	385	15	2	1/2
15446	11	Ripa da porta_Modulado	MDP	1817	35	12	6	1/2
15447	10	Lateral_Modulado	MDP	2040	335	12	2	2/2
15448	9	Tampo_Modulado	MDP	2370	335	12	1	1/2
15449	8	Lateral interna_Modulado	MDP	1918	335	12	2	2/2
15450	7	Tampo maleiro_Modulado	MDP	1606	335	12	1	2/2
15451	6	Prateleira maior_Modulado	MDP	1606	267	12	1	2/2
15452	5	Prateleira menor superior movel_Modulado	MDP	370	335	12	2	2/2
15453	4	Prateleira menor fixa_Modulado	MDP	370	335	12	6	2/2
15454	3	Painel de travamento_Modulado	MDP	1606	385	15	1	1/2
15455	2	Divisão nicho_modulado	MDP	267	267	12	1	2/2
15456	1	Divisão menor_modulado	MDP	410	317	12	2	1/2

LISTADE FERRAGENS

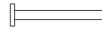
A  Parafuso 3,5x12 X78	B  Parafuso 3,5x25 (Porta e Moldura) X26	C  Parafuso 5x40 (montagem estrutura) X74
D  Batente curvo 02 furos da PORTA X01	E  Dobradiça X10	F  Calço Dobradiça X10
H  Sapata X08	I  Fixador de Costas X15	J  Puxador Madeira 200 X 20 X 15MM X02
L  Conector X05	K  Puxador Madeira 320 X 20 X 15MM X02	G  Prego 8x8 X70

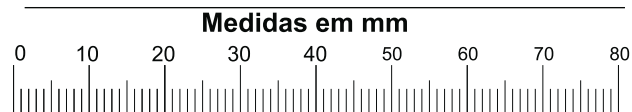

Ao solicitar assistência, informe o número da peça e a letra do acessório

01 Montagem do Rodapé

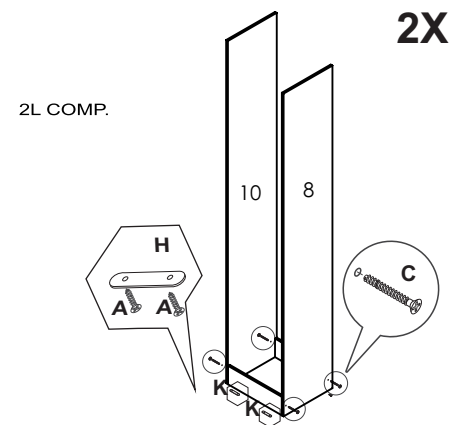

02 Montagem das Prateleiras

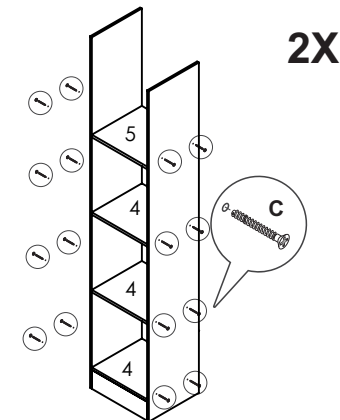

03 Montagem do Tampo Superior nos dois Módulos

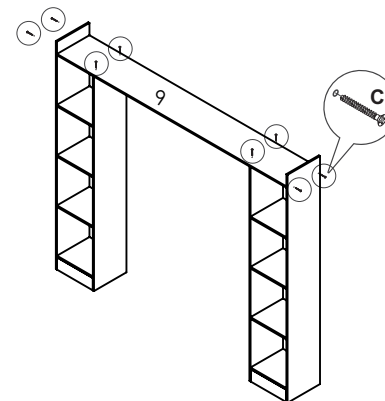

04 Montagem do Painel de Travamento

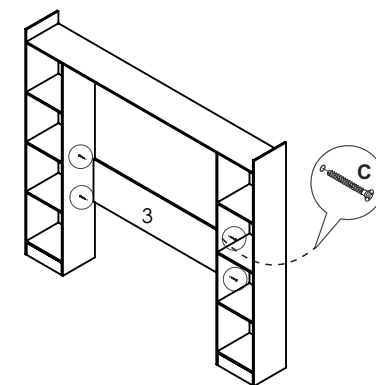

05 Montagem dos Tamos Inferiores

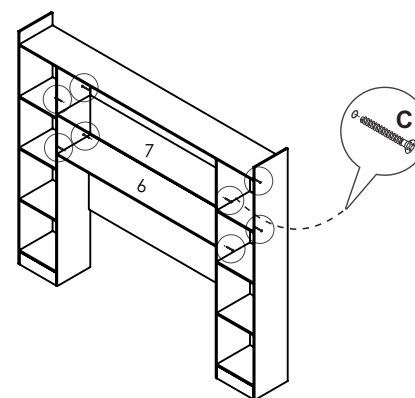

06 Montagem das Divisões Superiores

